

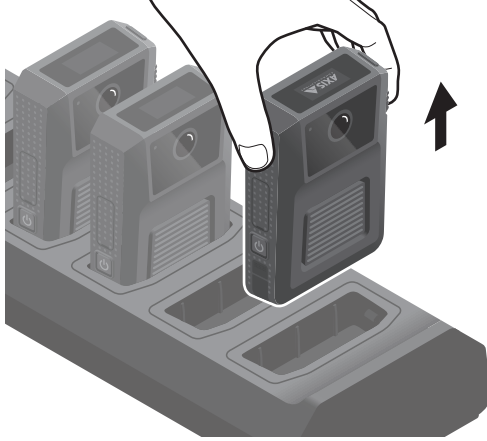

Daily use guide



AXIS W120 Body Worn Camera









 → 

  

30 sec

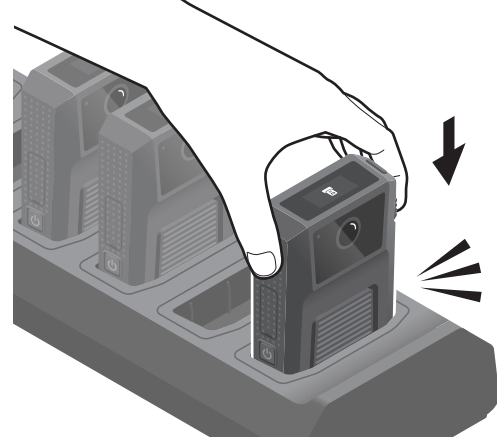







 → 

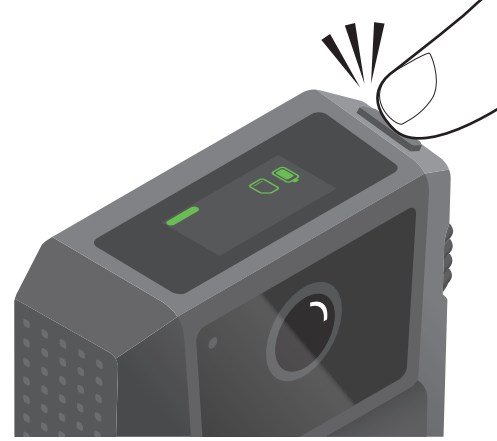







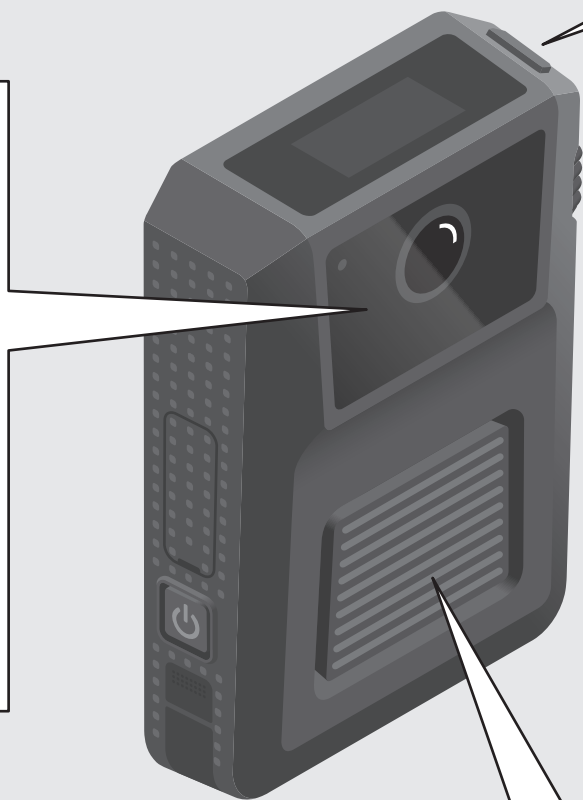
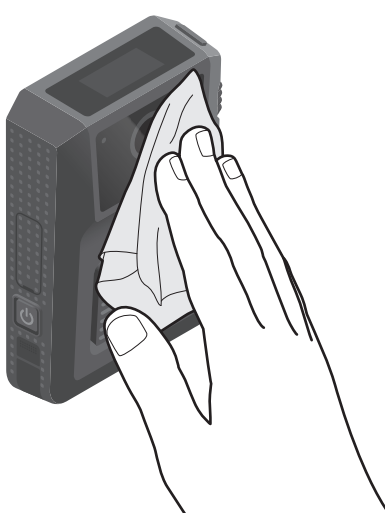

 → 





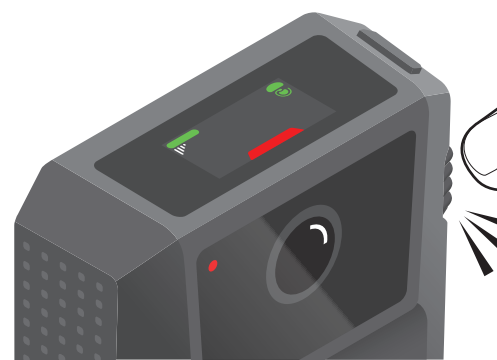





 → 

2x

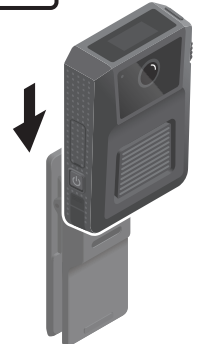











180°





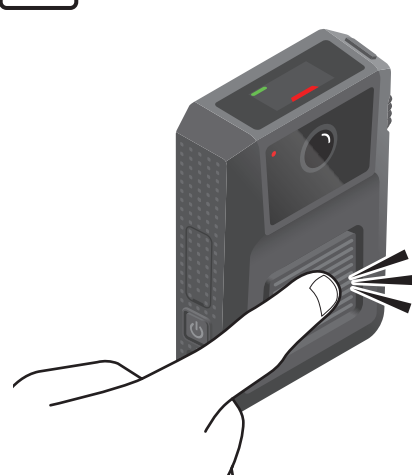





 → 

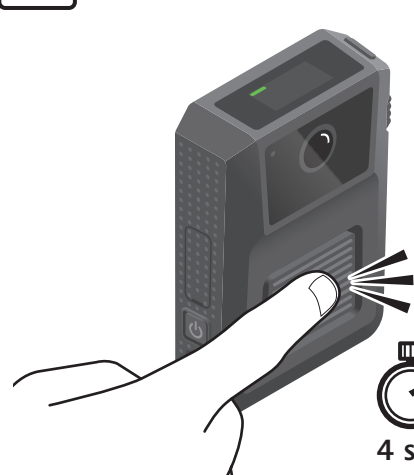



 → 

4 sec

