

KODAK Hearing Aid Battery K675ZA

(P675-Mercury Free)

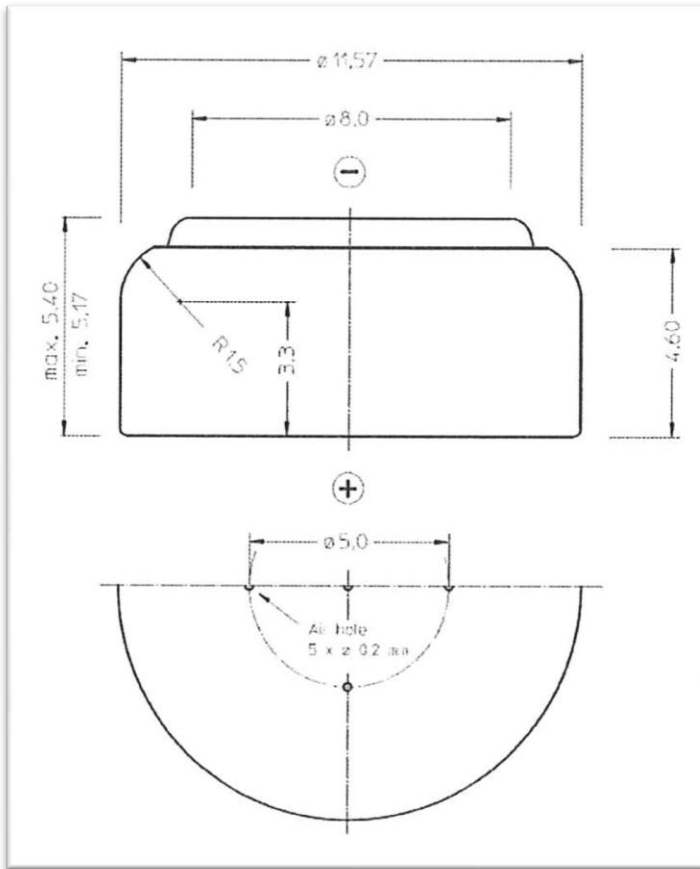

Specifications:

Chemical system:	Zinc / Air
Designations:	IEC PR 44, ANSI 7003ZD
Nominal Voltage:	1.45V
Nominal Capacity:	650 mAh *
Internal Impedance:	max. 4 Ω @ 1kHz
Weight:	approx 1.83g
Volume:	approx 0.55ccm
Storage conditions:	
-Temperature:	10 – 30 °C
-Relative Humidity:	20 – 80 %
Operating conditions:	
-Temperature:	0 – 45 °C
-Relative Humidity:	25 – 70 %



High Rate Pulse Capacity: 570 mAh **

High Rate Pulse Energy: 700 mWh **

* Power test 24 mA / 8 mA for 100 ms every 2 hours, for 12h/24h to 1.05V

**620 Ohms 12h/day to 1.1V

Note:

- 1) No added Mercury / 99.9999% Mercury Free
- 2) No added Lead /99.999% Lead Free
- 3) No added Cadmium / 99.9999% Cadmium Free
- 4) No added PFOS (Perfluorooctane sulfonates)
- 5) This battery complies with ANSI C18, IEC 60086, and EU Directive 2006/66/EC, 2006/122/EC
- 6) Batteries are NOT subject to European RoHS regulations.
- 7) Primary Batteries (non-Rechargeable) are not subject to China RoHS regulations.
- 8) MSDS sheets are available on request from Strand Europe Ltd.