



FS-1370DN PF-100

PARTS LIST

Published in March 2010
2L0PL070
First Edition

NOTES

1. Indicate parts number and parts description together with the machine model name when placing an order.

e.g.	Parts Number	Parts Name	Machine Model	Quantity
	302L004010	COVER RIGHT	FS-1370DN	1

2. Symbols in the "Parts Number" column.

- Parts with "•" are component parts or sub-assemblies of the assembly appearing immediately above them.

e.g.	Parts Number	Parts Name	Parts Number	Parts Name
	302L000010	COVER RIGHT ASSY	• 302L004010	COVER RIGHT
			• 302LZ04030	COVER DIMM

- Parts with "••" are component parts or sub-assembly with "•" appearing immediately above them.

e.g.	Parts Number	Parts Name	Parts Number	Parts Name
	•302HS94000	PLATE BOTTOM ASSY	••302F909210	PAD BOTTOM

- Parts with "⊙" indicate regular maintenance parts.

———— CONTENTS ————

FIG. 1	Covers	2
FIG. 2	Frames	4
FIG. 3	Paper Cassette	6
FIG. 4	Paper Feed Section 1	8
FIG. 5	Paper Feed Section 2	10
FIG. 6	Image Formation Section	12
FIG. 7	Developing Section	14
FIG. 8	Fuser Section	16
FIG. 9	Drive Section	18
FIG. 10	Duplex Section	20
FIG. 11	Electrical Components	22
FIG. 12	Maintenance Kits	24
	• INDEX	25

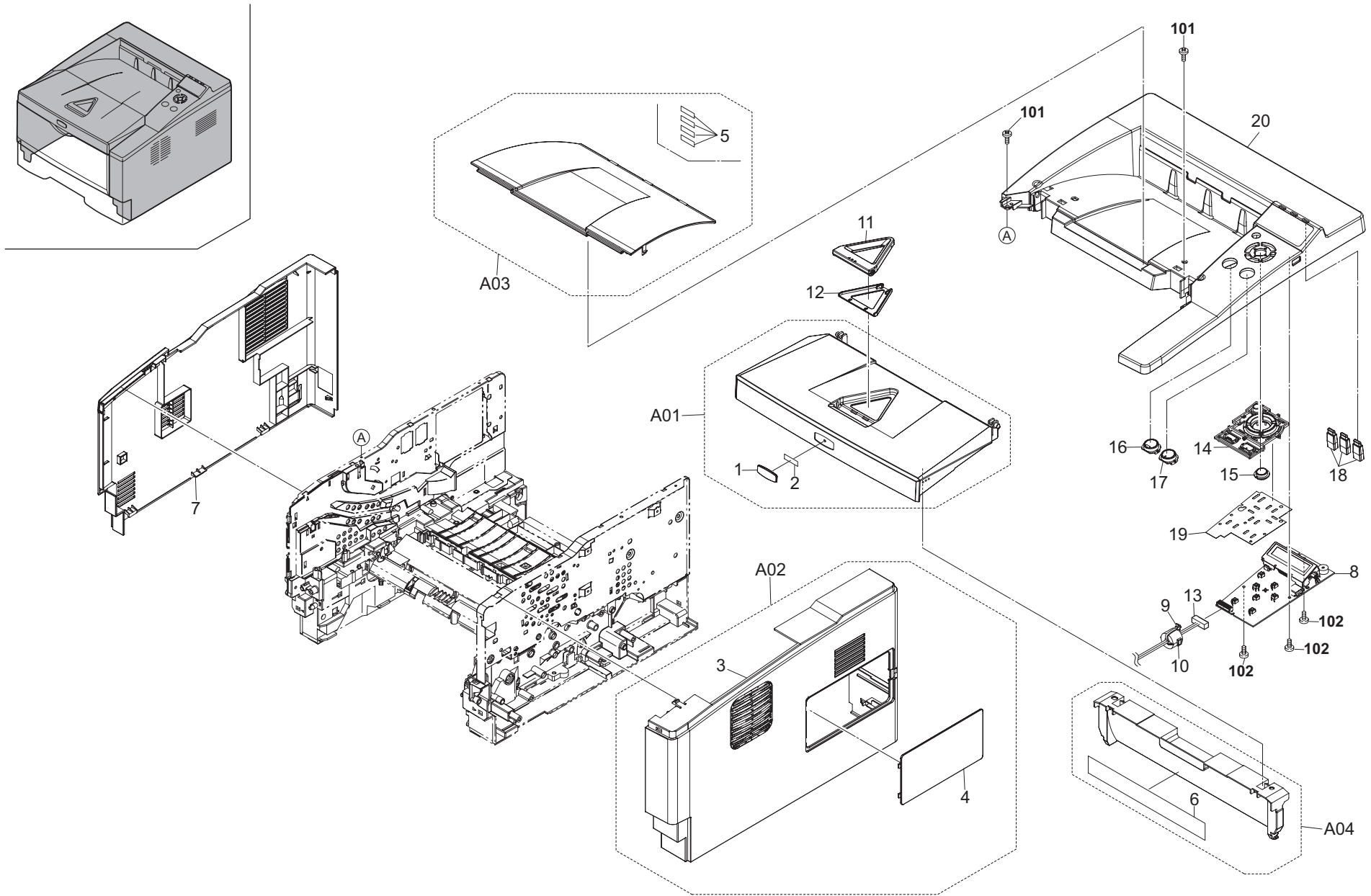

FIG. 1 Covers

2L0

Ref. No.	Part.No.	Alternative.	Description	Quantity		
				120	230	240
⊙ A01	302HS94020	2HS94020	LID TOP ASSY	1	1	1
1	*302F904120	2F904120	EMBLEM KYOCERA	1	1	1
2	*302F904130	2F904130	TAPE EMBLEM	1	1	1
⊙ A02	302L000010	2L000010	COVER RIGHT ASSY	1	1	1
3	*302L004010	2L004010	COVER RIGHT	1	1	1
4	*302LZ04030	2LZ04030	COVER DIMM	1	1	1
⊙ A03	302H494010	2H494010	COVER TOP B(N) KIT SP	1	1	1
5	*302HS04170	2HS04170	SHEET TOP COVER	4	4	4
⊙ A04	302HS94121	2HS94121	COVER FRONT ASSY (2HS) SP	1	1	1
6	*302HS34080	2HS34080	LABEL JAM TK OPERATION	1	1	1
⊙ 7	302LZ04010	2LZ04010	COVER LEFT	1	1	1
⊙ 8	302L094050	2L094050	PARTS PWB LCD SP	1	1	1
9	7YZM420002++H01	YZ045260	ACCESS.BAND	1	1	1
10	7YBEJ0J0D001H01	YB045400	FERRITE CORE	1	1	1
⊙ 11	302HS04070	2HS04070	COVER RACK	1	1	1
⊙ 12	302HS04160	2HS04160	COVER RACK B	1	1	1
13	302H446020	2H446020	CONN.CORD ASSY LCD-RELAY S03394	1	1	1
14	302H405010	2H405010	BUTTON A	1	1	1
15	302H405020	2H405020	BUTTON B	1	1	1
16	302H405030	2H405030	BUTTON C	1	1	1
17	302H405040	2H405040	BUTTON D	1	1	1
18	302H405110	2H405110	LENS LED	3	3	3
19	302H405080	2H405080	SHEET BUTTON	1	1	1
⊙ 20	302L094030	2L094030	PARTS COVER TOP ASSY SP	1	1	1

Ref. No.	Part.No.	Alternative.	Description	Quantity		
				120	230	240
101	7BB200410H	BB105700	+BIND T.T P SCREW 4X10			
102	7BB200308H	BB105660	+BIND T.T P SCREW 3X8			

- Parts with "*" are component parts or sub-assemblies of the assembly appearing immediately above them.
- Parts with "⊙" indicate regular maintenance parts.

- Parts with "••" are component parts or sub-assembly with "•" appearing immediately above them.

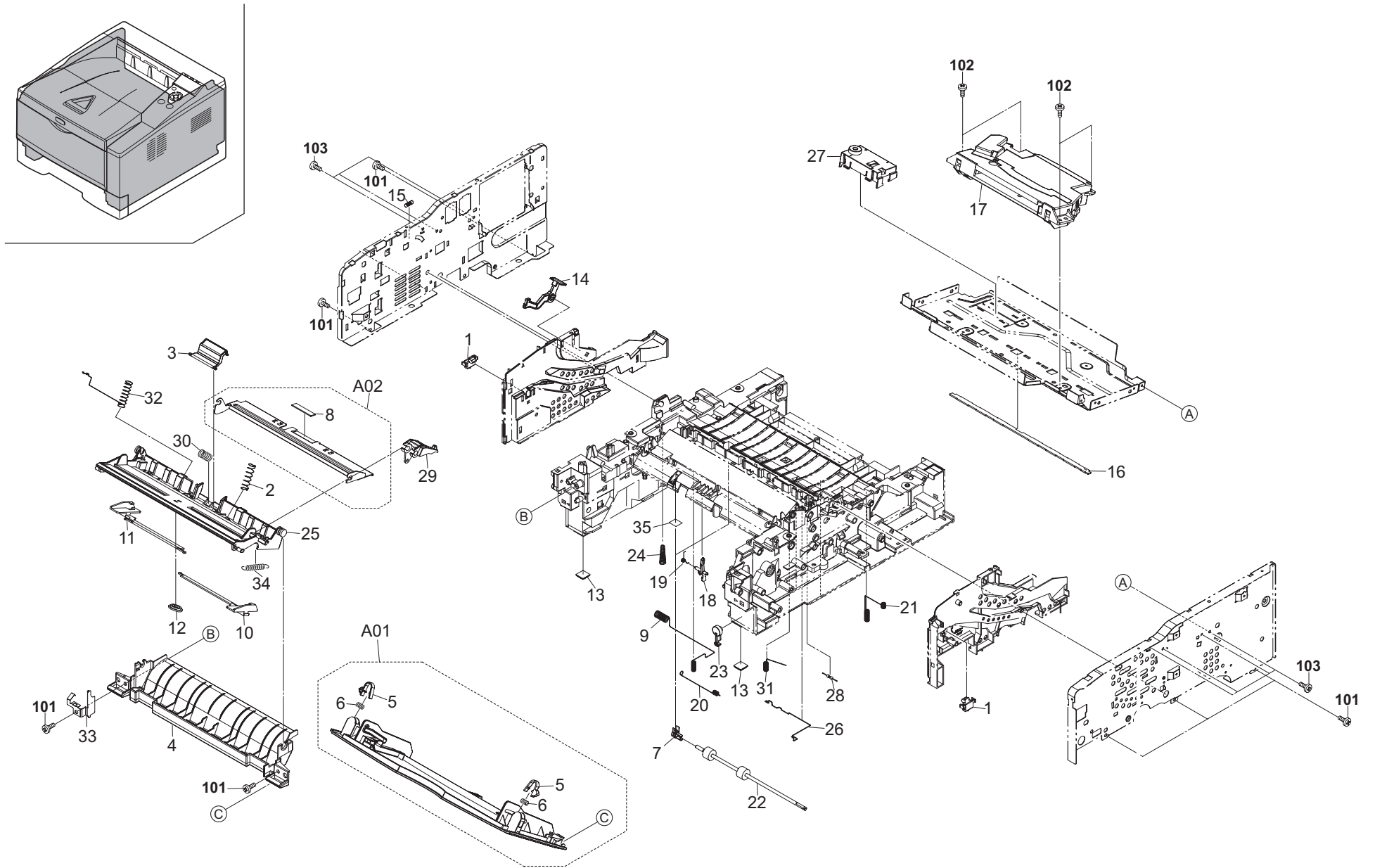

FIG. 2 Frames

2L0

	Ref. No.	Part.No.	Alternative.	Description	Quantity		
					120	230	240
	1	302F902420	2F902420	LOCK COVER TOP R	2	2	2
	2	302F908270	2F908270	SP BOTTOM MPF L	1	1	1
⊙	3	302HS94040	2HS94040	SEPARATOR MPF ASSY	1	1	1
	4	302LZ08020	2LZ08020	GUIDE TURN MPF	1	1	1
⊙	A01	302LZ94090	2LZ94090	PARTS TRAY MPF ASSY SP	1	1	1
	5	*302F908200	2F908200	LOCK COVER	2	2	2
	6	*302HS08320	2HS08320	SPRING COVER MPF	2	2	2
	7	302HS24130	2HS24130	BUSH 4 DU ROLL	2	2	2
⊙	A02	302HS94050	2HS94050	PLATE BOTTOM MPF ASSY	1	1	1
	8	*302F908310	2F908310	PAD FRICTION MPF	1	1	1
	9	302HS02160	2HS02160	SPRING MC	1	1	1
	10	302HS08241	2HS08241	GUIDE MPF R	1	1	1
	11	302HS08251	2HS08251	GUIDE MPF L	1	1	1
	12	5MVG137DN032	2A806720	GEAR MPF /A-49 MPF A4	1	1	1
⊙	13	302J002010	2J002010	FOOT	2	2	2
⊙	14	302HS02090	2HS02090	LEVER STOPPER DLP	1	1	1
	15	302HS02100	2HS02100	SPRING STOPPER DLP	1	1	1
⊙	16	302LZ94010	2LZ94010	PARTS PWB ERASER SP	1	1	1
⊙	17	302LZ93030	2LZ93030	LK-170	1	1	1
	18	302LZ24030	2LZ24030	ACTUATOR REGIST	1	1	1
	19	302HS24070	2HS24070	SPRING ACTUATOR REG	1	1	1
	20	302H402060	2H402060	SPRING EARTH DU FEED	1	1	1
	21	302HS02330	2HS02330	SPRING EARTH DU PLATE	1	1	1
⊙	22	302HS24160	2HS24160	ROLLER DU	2	2	2
⊙	23	302HS02650	2HS02650	HOOK PF	1	1	1
	24	302HS02470	2HS02470	SPRING PIN BIAS	1	1	1
	25	302HS08050	2HS08050	BASE MPF	1	1	1
	26	302H402040	2H402040	SPRING REG GND	1	1	1
⊙	27	302H994360	2H994360	PARTS FULL SENSOR ASSY SP	1	1	1
	28	7RHA2H10701+H01	RH043740	M.GLAZE R. 100MJ 1/2W	1	1	1
	29	302HS08100	2HS08100	BRACKET BOTTOM	1	1	1
	30	302HS08170	2HS08170	SPRING SEPARATOR	1	1	1
	31	302HS24300	2HS24300	SPRING CONTACT TC	1	1	1
	32	302HS08210	2HS08210	SPRING EARTH MPF	1	1	1
	33	302HS08230	2HS08230	PLATE EARTH BOTTOM	1	1	1
	34	302HS08270	2HS08270	SPRING BRACKET	1	1	1
	35	302HS02700	2HS02700	SHEET BUSH DU	1	1	1

Ref. No.	Part.No.	Alternative.	Description	Quantity		
				120	230	240
101	7BB200410H	BB105700	+BIND T.T P SCREW 4X10			
102	7BB600308H	BB055190	+BIND SCREW M3X8 CRFREE SR			
103	7BB100306H1	BB105820	+BIND T.T S SCREW 3X6			

- Parts with "*" are component parts or sub-assemblies of the assembly appearing immediately above them.
- Parts with "⊙" indicate regular maintenance parts.

- Parts with "••" are component parts or sub-assembly with "•" appearing immediately above them.

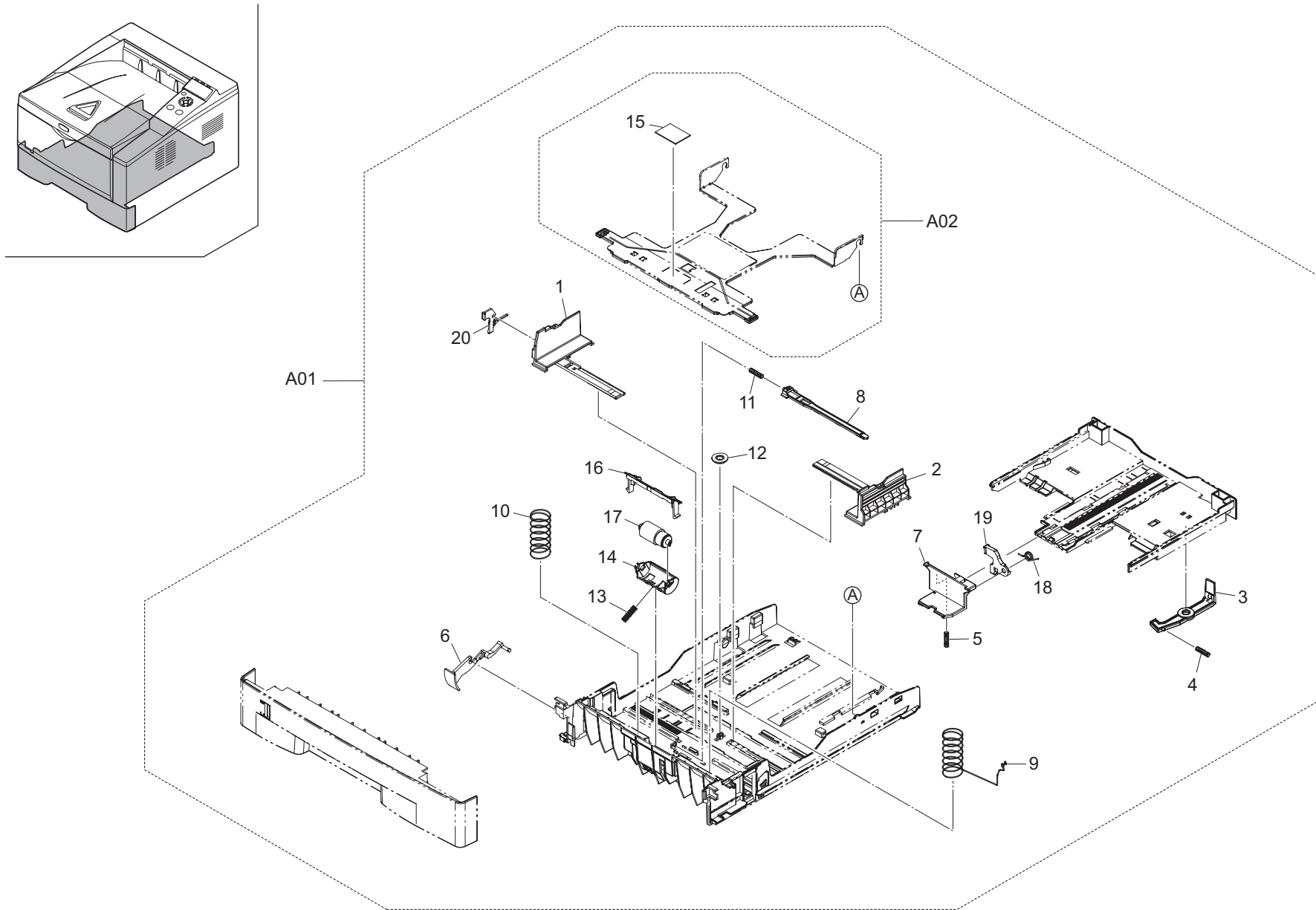

FIG. 3 Paper Cassette

	Ref. No.	Part.No.	Alternative.	Description	Quantity		
					120	230	240
⊙	A01	302LZ93070	2LZ93070	CT-170	1	1	1
	1	*2FM06010	5MVX765SH004	GUIDE SIDE L /B-11 CASSETTE A2	1	1	1
	2	*2FM06020	5MVX765SH005	GUIDE SIDE R /B-11 CASSETTE A2	1	1	1
	3	*302F909031	2F909031	LEVER BASE CAS REAR	1	1	1
	4	*302F909040	2F909040	SPRING BASE CAS REAR	1	1	1
	5	*302HN09190	2HN09190	SPRING FIX	1	1	1
	6	*302HS09070	2HS09070	PAPER INDICATOR	1	1	1
	7	*302HS09081	2HS09081	CURSOR END	1	1	1
	8	*302HS09100	2HS09100	LOCK BOTTOM	1	1	1
	9	*302HS09120	2HS09120	SPRING BOTTOM L	1	1	1
	10	*302HS09130	2HS09130	SPRING BOTTOM R	1	1	1
	11	*302HS09140	2HS09140	SPRING LOCK BOTTOM	1	1	1
	12	*302HS09160	2HS09160	GEAR CASSETTE	1	1	1
	13	*302HS09180	2HS09180	SPRING RETARD	1	1	1
	14	*302HS09260	2HS09260	HOLDER RETARD	1	1	1
⊙	A02	*302HS94000	2HS94000	PLATE BOTTOM ASSY	1	1	1
	15	**302F909210	2F909210	PAD BOTTOM	1	1	1
	16	*302LZ09030	2LZ09030	GUIDE RETARD	1	1	1
⊙	17	*302BR06521	2BR06521	RETARD ROLL ASSY /43487V0005 A4	1	1	1
	18	*5MMW171LD006	2A807530	SPRING STOPPER /A49 CASSETTE A4	1	1	1
	19	*5MVX541DG002	2A807191	LEVER REAR /A-49 CASSETTE A3	1	1	1
	20	*5MVX541DG003	2A807161	LEVER SIDE /A-49 CASSETTE A3	1	1	1

- Parts with "*" are component parts or sub-assemblies of the assembly appearing immediately above them.
- Parts with "⊙" indicate regular maintenance parts.

- Parts with "**" are component parts or sub-assembly with "*" appearing immediately above them.

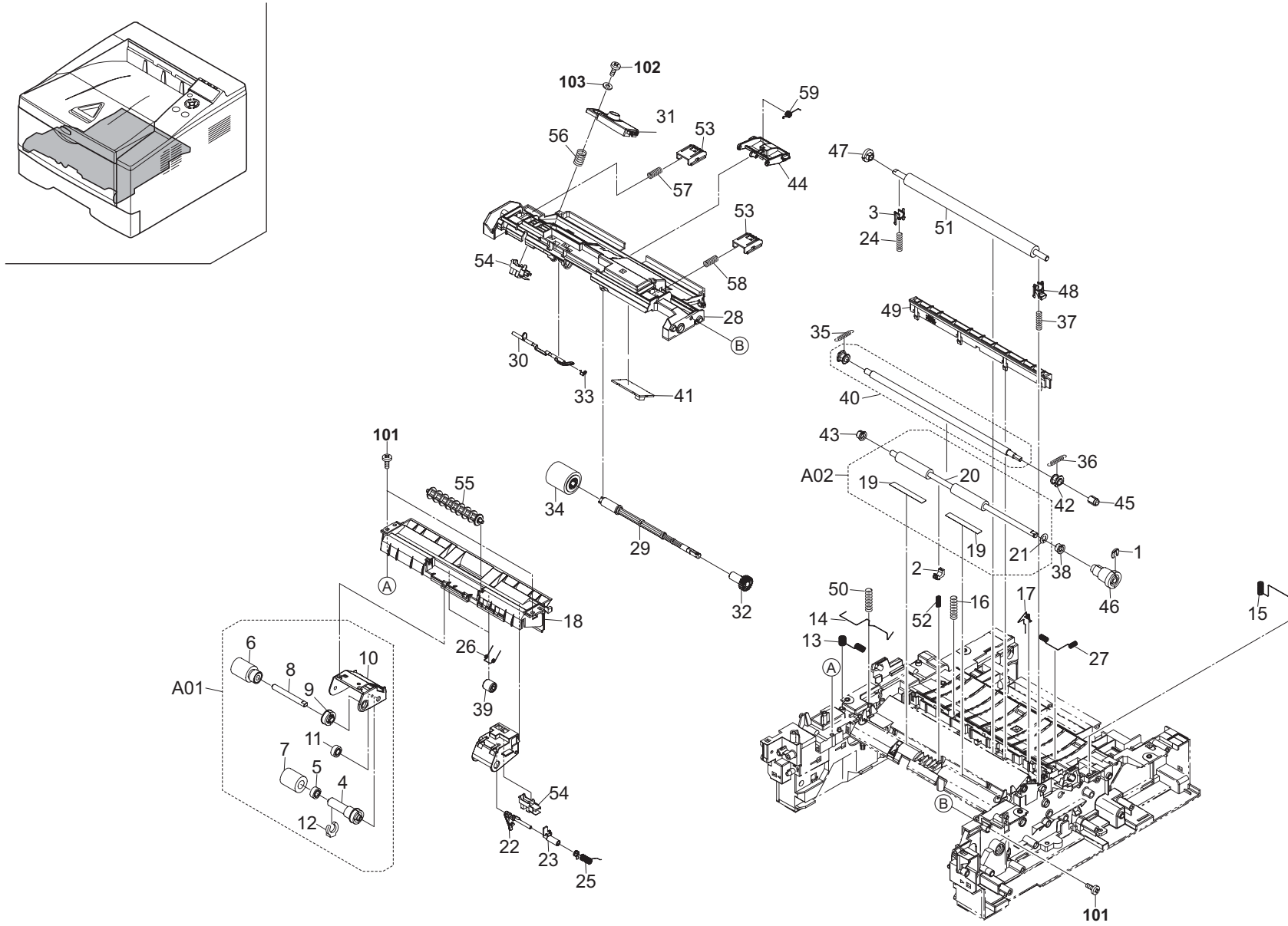

FIG. 4 Paper Feed Section 1

2L0

Ref. No.	Part.No.	Alternative.	Description	Quantity			
				120	230	240	
⊙	1	5MVX111DN003	2A806250	RING STOPPER /A-49 FEED A4	1	1	1
	2	2FM02180	5MVX221DN020	BUSH REGIST C /B-11 FRAME A3	1	1	1
⊙	3	302A816031	2A816031	BUSH TC R /A-49 FEED A4	1	1	1
⊙	A01	302HS94032	2HS94032	HOLDER FEED ASSY	1	1	1
	4	*302F906170	2F906170	JOINT PICKUP A	1	1	1
	5	*302F906180	2F906180	JOINT PICKUP B	1	1	1
	6	*302F906230	2F906230	PULLEY FEED ASSY	1	1	1
	7	*302F906240	2F906240	PULLEY PICKUP ASSY	1	1	1
	8	*302F906272	2F906272	SHAFT FEED L	1	1	1
	9	*302F906280	2F906280	GEAR FEED Z30H	1	1	1
	10	*302HS06020	2HS06020	HOLDER FEED	1	1	1
⊙	11	*302HS06090	2HS06090	GEAR Z22S FEED	1	1	1
⊙	12	*5MVX111DN003	2A806250	RING STOPPER /A-49 FEED A4	1	1	1
	13	302LZ02100	2LZ02100	SPRING EARTH REG UP	1	1	1
	14	302HS02260	2HS02260	SPRING EARTH REG LOW	1	1	1
	15	302HS02340	2HS02340	SPRING EARTH RIGHT	1	1	1
	16	302HS02410	2HS02410	SPRING EARTH DU MID	1	1	1
	17	302HS02440	2HS02440	SPRING EARTH DLP PLATE	1	1	1
	18	302HS06010	2HS06010	FRAME FEED	1	1	1
⊙	A02	302HS94081	2HS94081	REGIST LOW KIT	1	1	1
	19	*302HS24181	2HS24181	SHEET REGIST	2	2	2
	20	*302HS24410	2HS24410	ROLLER REGIST LOW	1	1	1
	21	*7BC460529080H01	BC059590	CUT WASHER 5.2X9.0X0.8T(BLACK)	1	1	1
⊙	22	302HS06060	2HS06060	ACTUATOR EMPTY A	1	1	1
⊙	23	302HS06071	2HS06071	ACTUATOR EMPTY B	1	1	1
	24	302LZ24090	2LZ24090	SPRING TC L	1	1	1
	25	302HS06120	2HS06120	SPRING ACTUATOR	1	1	1
	26	302HS06130	2HS06130	SPRING PULLEY	2	2	2
	27	302HS24310	2HS24310	SPRING EARTH BRUSH	1	1	1
	28	302HS08011	2HS08011	FRAME MPF	1	1	1
	29	302HS08080	2HS08080	SHAFT FEED MPF	1	1	1
⊙	30	302HS08110	2HS08110	ACTUATOR MPF	1	1	1
⊙	31	302HS94150	2HS94150	EMPTY SENSOR KIT SP	1	1	1
⊙	32	302HS08160	2HS08160	GEAR Z20S MPF	1	1	1
	33	302HS08190	2HS08190	SPRING ACTUATOR	1	1	1
⊙	34	302HS08260	2HS08260	ROLLER M/P ASSY	1	1	1
⊙	35	302LZ24120	2LZ24120	SPRING REGIST LB	1	1	1
⊙	36	302LZ24110	2LZ24110	SPRING REGIST RB	1	1	1
	37	302HS24400	2HS24400	SPRING TC R	1	1	1
	38	302HS24460	2HS24460	BUSH REGIST R	1	1	1
	39	5MVM273DB005	2A820100	PULLEY EXIT /A-49 FUSER A3	2	2	2
⊙	40	302LZ94050	2LZ94050	PARTS ROLLER REGIST UP SP	1	1	1
	41	302HS01130	2HS01130	P.W.B RFID WITH SOFTWARE	1	1	1
	42	302HS24120	2HS24120	BUSH REGIST	1	1	1
	43	302HS24140	2HS24140	BUSH 6 EW	1	1	1
	44	302HS08340	2HS08340	COVER REG SW	1	1	1
⊙	45	302HS24190	2HS24190	GEAR Z14R REG UP	1	1	1
⊙	46	302HS24200	2HS24200	GEAR Z21L-Z23L REG LOW	1	1	1
⊙	47	302LZ24010	2LZ24010	GEAR Z17L TC	1	1	1
⊙	48	302HS24250	2HS24250	BUSH TC R	1	1	1

Ref. No.	Part.No.	Alternative.	Description	Quantity			
				120	230	240	
⊙	49	302H494080	2H494080	HOLDER DC BRUSH ASSY	1	1	1
	50	302HS24280	2HS24280	SPRING RELEASE TC L	1	1	1
⊙	51	302LZ94060	2LZ94060	PARTS ROLLER TRANSFER E SP	1	1	1
⊙	51	302LZ94070	2LZ94070	PARTS ROLLER TRANSFER A SP	1	1	1
	52	302HS24360	2HS24360	SPRING REGIST C	1	1	1
⊙	53	5MVX431DN005	2FV02100	LEVER LOCK DLP	2	2	2
	54	7NXSG2481+++H01	NX052600	SENSOR OPT.	2	2	2
	55	302HS06050	2HS06050	PULLEY FEED	1	1	1
	56	5MMW261LD036	2A814570	SPRING TE SENSOR /A-49 DLP A4	1	1	1
	57	5MMW261LD067	2FV02270	SPRING LEVER LOCK L	1	1	1
	58	5MMW261LD068	2FV02280	SPRING LEVER LOCK R	1	1	1
	59	302HS08351	2HS08351	SPRING COVER REG	1	1	1
	101	7BB200410H	BB105700	+BIND T.T P SCREW 4X10			
	102	7BB202308H	BB105690	+TP-FLAT T.T P SCREW 3X8			
	103	7BC00030A080H01	BC046150	WASHER M3X10X0.8T			

- Parts with "*" are component parts or sub-assemblies of the assembly appearing immediately above them.
- Parts with "⊙" indicate regular maintenance parts.

- Parts with "••" are component parts or sub-assembly with "•" appearing immediately above them.

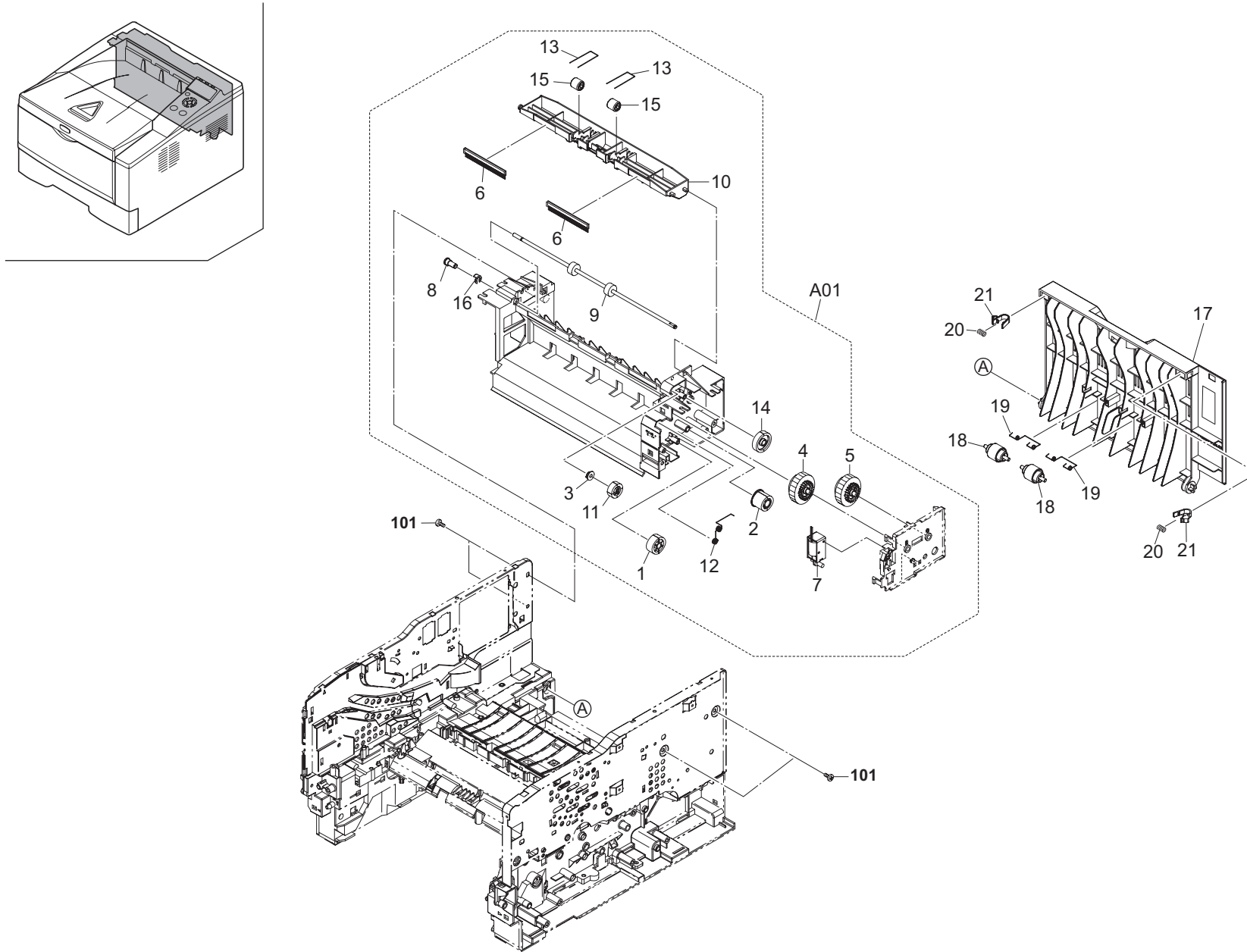

FIG. 5 Paper Feed Section 2

2L0

Ref. No.	Part.No.	Alternative.	Description	Quantity		
				120	230	240
⊙ A01	302LZ94100	2LZ94100	PARTS FD ASSY (2LZ) SP	1	1	1
⊙ 1	*2BL06380	2BL06380	GEAR Z25 JOINT	1	1	1
⊙ 2	*2FM02350	5MVG133DN022	GEAR Z22 /B-11 FRAME A4	1	1	1
⊙ 3	*302F929140	2F929140	BUSH DU	1	1	1
⊙ 4	*302FM94020	2FM94020	GEAR CLUTCH ASSY A SP	1	1	1
⊙ 5	*302FM94030	2FM94030	GEAR CLUTCH ASSY B SP	1	1	1
⊙ 6	*302H428020	2H428020	DISCHARGER FD	2	2	2
⊙ 7	*302H494070	2H494070	SOLENOID ASSY SP	1	1	1
⊙ 8	*302HN29050	2HN29050	BUSH DU	1	1	1
⊙ 9	*302HS28030	2HS28030	ROLLER FD UP	1	1	1
10	*302HS28041	2HS28041	COVER FD	1	1	1
⊙ 11	*302HS28060	2HS28060	GEAR Z21S	1	1	1
12	*302HS28110	2HS28110	SPRING EARTH	1	1	1
13	*302HS28141	2HS28141	SPRING PULLEY	2	2	2
⊙ 14	*302HS28170	2HS28170	GEAR FD Z29S	1	1	1
15	*5MVM273DB005	2A820100	PULLEY EXIT /A-49 FUSER A3	2	2	2
16	*5MVX111DN007	2BT11070	STOPPER 3 /2BT1107 A4	1	1	1
⊙ 17	302HS94160	2HS94160	COVER REAR ASSY SP	1	1	1
18	302HS28070	2HS28070	PULLEY EXIT	2	2	2
19	302HS28120	2HS28120	SPRING EXIT	2	2	2
20	302HS08320	2HS08320	SPRING COVER MPF	2	2	2
21	302F908200	2F908200	LOCK COVER	2	2	2

Ref. No.	Part.No.	Alternative.	Description	Quantity		
				120	230	240
101	7BB200410H	BB105700	+BIND T.T P SCREW 4X10			

- Parts with "*" are component parts or sub-assemblies of the assembly appearing immediately above them.
- Parts with "⊙" indicate regular maintenance parts.

- Parts with "••" are component parts or sub-assembly with "•" appearing immediately above them.

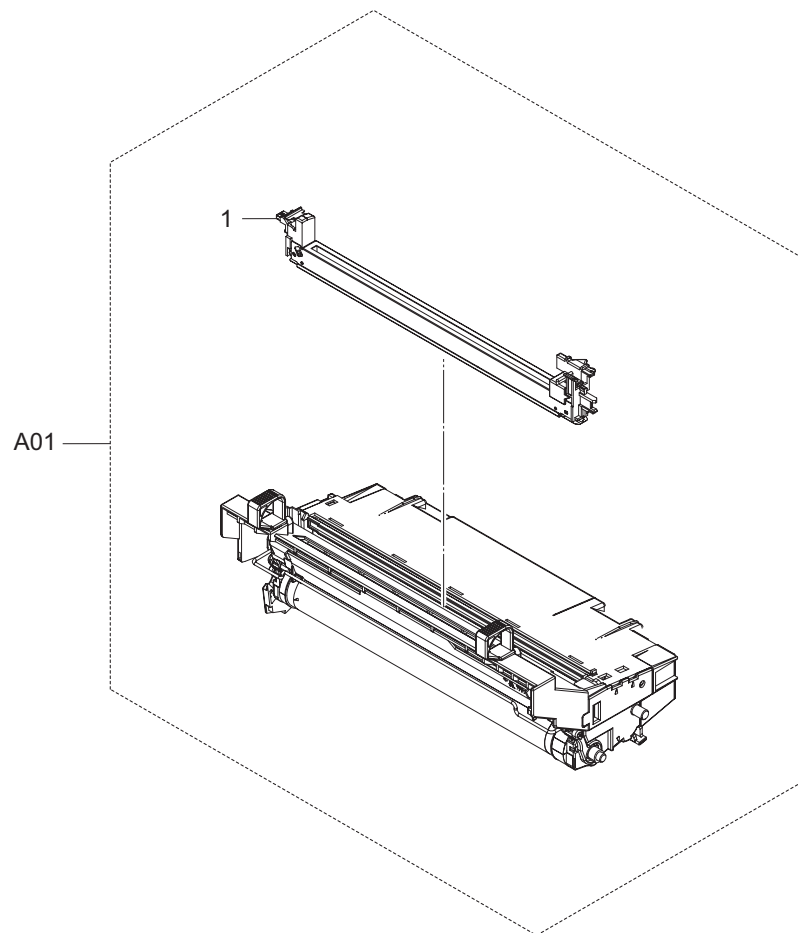
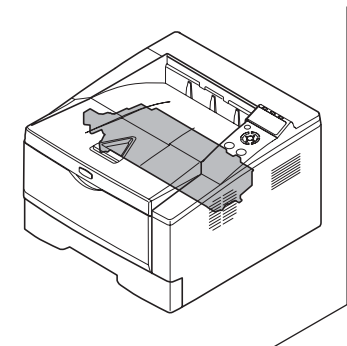

FIG. 6 Image Formation Section

2L0

	Ref. No.	Part.No.	Alternative.	Description	Quantity		
					120	230	240
⊙	A01	302LZ93060	2LZ93060	DK-170	1	1	1
⊙	1	•302HS93070	2HS93070	MC-130	1	1	1

- Parts with "•" are component parts or sub-assemblies of the assembly appearing immediately above them.
- Parts with "⊙" indicate regular maintenance parts.

- Parts with "••" are component parts or sub-assembly with "•" appearing immediately above them.

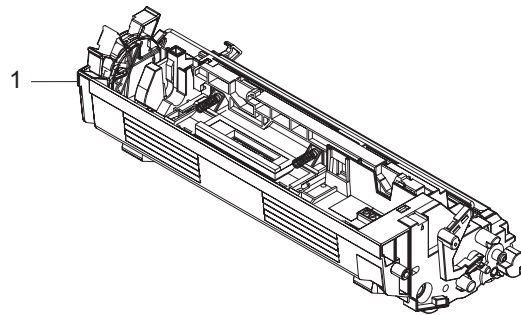
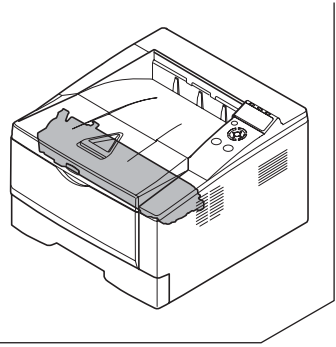

FIG. 7 Developing Section

2L0

	Ref. No.	Part.No.	Alternative.	Description	Quantity		
					120	230	240
⊙	1	302LZ93010	2LZ93010	DV-170(E)		1	
⊙	1	302LZ93020	2LZ93020	DV-172(U)	1		
⊙	1	302LZ93080	2LZ93080	DV-174(AO)			1

- Parts with "•" are component parts or sub-assemblies of the assembly appearing immediately above them.
- Parts with "⊙" indicate regular maintenance parts.

- Parts with "••" are component parts or sub-assembly with "•" appearing immediately above them.

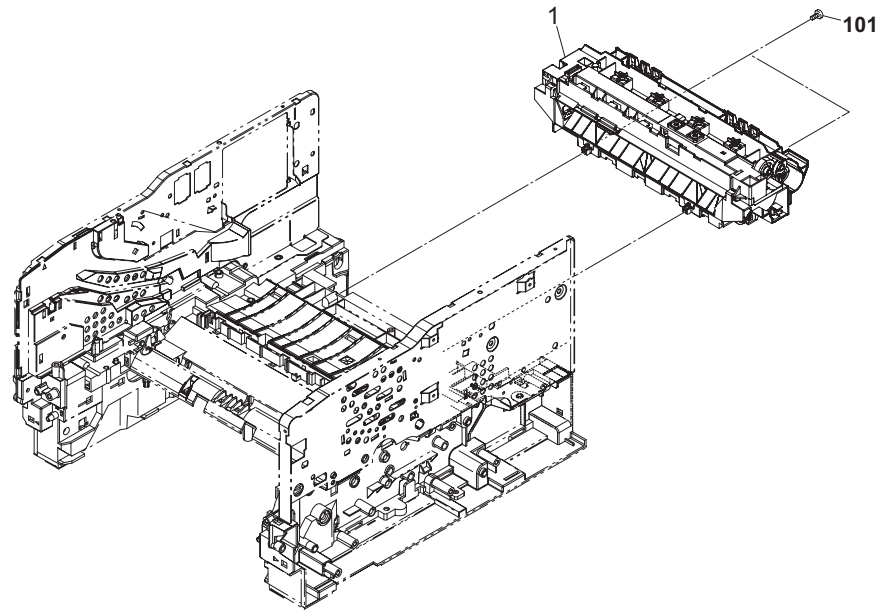
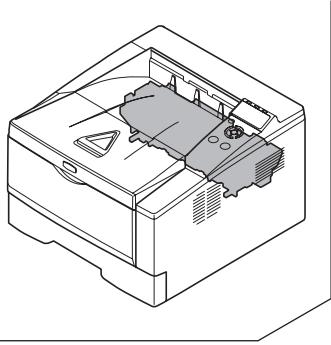

FIG. 8 Fuser Section

2L0

	Ref. No.	Part.No.	Alternative.	Description	Quantity		
					120	230	240
⊙	1	302LZ93040	2LZ93040	FK-170(E)		1	1
⊙	1	302LZ93050	2LZ93050	FK-170(U)	1		

	Ref. No.	Part.No.	Alternative.	Description	Quantity		
					120	230	240
	101	7BB200410H	BB105700	+BIND T.T P SCREW 4X10			

- Parts with "•" are component parts or sub-assemblies of the assembly appearing immediately above them.
- Parts with "⊙" indicate regular maintenance parts.

- Parts with "••" are component parts or sub-assembly with "•" appearing immediately above them.

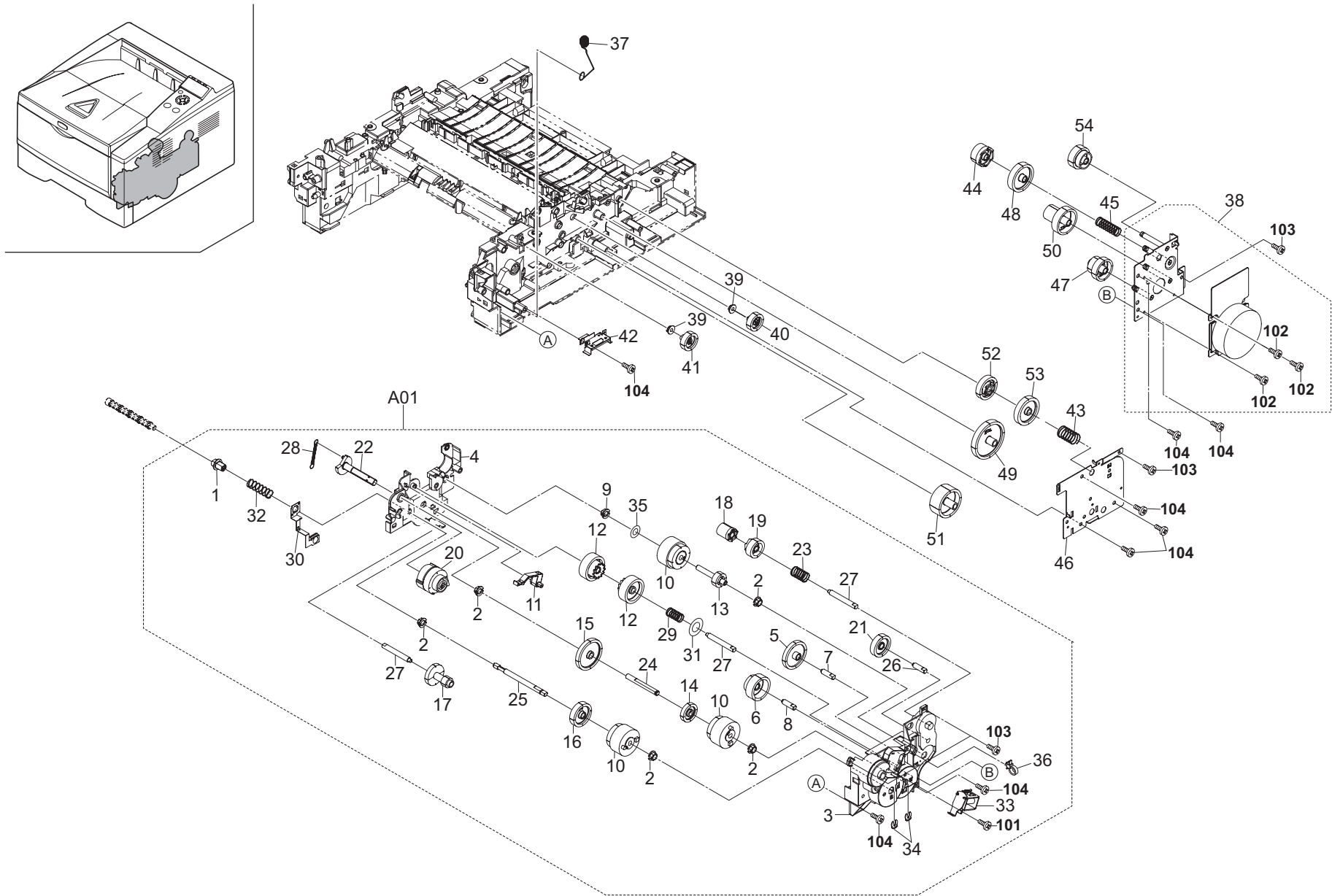

FIG. 9 Drive Section

2L0

Ref. No.	Part.No.	Alternative.	Description	Quantity		
				120	230	240
⊙ A01	302H493040	2H493040	DR-150	1	1	1
1	*302F931350	2F931350	JOINT SHAFT CASSETTE	1	1	1
2	*302F931490	2F931490	BUSH FEED DRIVE	5	5	5
3	*302H431010	2H431010	HOLDER DRIVE	1	1	1
4	*302H431020	2H431020	COVER HOLDER DRIVE	1	1	1
⊙ 5	*302H431030	2H431030	GEAR Z42R	1	1	1
⊙ 6	*302H431040	2H431040	GEAR Z34L-Z24L	1	1	1
7	*302H431050	2H431050	PIN HOLDER A	1	1	1
8	*302H431060	2H431060	PIN HOLDER B	1	1	1
9	*302H431070	2H431070	BUSH DRIVE 6	1	1	1
⊙ 10	*302HN44111	2HN44111	CLUTCH FEED	3	3	3
11	*302HS31050	2HS31050	LEVER LIFT BOTTOM	1	1	1
⊙ 12	*302HS31090	2HS31090	GEAR Z37L FREE	2	2	2
⊙ 13	*302HS31100	2HS31100	GEAR Z20L CLUTCH	1	1	1
⊙ 14	*302HS31120	2HS31120	GEAR Z27L CLUTCH	1	1	1
⊙ 15	*302HS31130	2HS31130	GEAR Z45R CLUTCH	1	1	1
⊙ 16	*302HS31140	2HS31140	GEAR Z35R IDLE	1	1	1
⊙ 17	*302HS31150	2HS31150	GEAR Z31L-Z14S	1	1	1
⊙ 18	*302HS31190	2HS31190	GEAR Z17R FREE	1	1	1
⊙ 19	*302HS31200	2HS31200	GEAR Z26L FREE	1	1	1
⊙ 20	*302HS31230	2HS31230	GEAR Z38S MPF	1	1	1
⊙ 21	*302HS31260	2HS31260	GEAR Z32R	1	1	1
22	*302HS31281	2HS31281	LIFT BOTTOM	1	1	1
23	*302HS31320	2HS31320	SPRING FREE MAG	1	1	1
24	*302HS31330	2HS31330	PIN CLUTCH	1	1	1
25	*302HS31340	2HS31340	SHAFT CASSETTE	1	1	1
26	*302HS31360	2HS31360	PIN HOLDER A	1	1	1
27	*302HS31370	2HS31370	PIN HOLDER B	3	3	3
28	*302HS31380	2HS31380	SPRING LIFT BOTTOM	1	1	1
29	*302HS31410	2HS31410	SPRING FREE Z37L	1	1	1
30	*302HS31420	2HS31420	EARTH PLATE DRIVE	1	1	1
31	*302HS31430	2HS31430	POLYSLIDER 9.5	1	1	1
32	*302HS31440	2HS31440	SPRING FEED	1	1	1
⊙ 33	*302HS44020	2HS44020	SOLENOID MPF	1	1	1
⊙ 34	*5MVX1111DN003	2A806250	RING STOPPER /A-49 FEED A4	2	2	2
35	*7BC06062C020H01	BC045240	POLY SLIDER WASHER M6.2X12X0.2T	1	1	1
36	*M2107250	M2107250	BAND,RSG-100(KITAGAWA)	1	1	1
37	302HS02370	2HS02370	SPRING EARTH CASSETTE	1	1	1
⊙ 38	302LZ94020	2LZ94020	PARTS MOTOR ASSY SP	1	1	1
39	302F929140	2F929140	BUSH DU	2	2	2
⊙ 40	302HS24220	2HS24220	GEAR Z25R DU FEED	1	1	1
⊙ 41	302HS24230	2HS24230	GEAR Z26L DU MID	1	1	1
42	302HS02381	2HS02381	PLATE PF CONNECTOR	1	1	1
43	302HS31310	2HS31310	SPRING FREE FUSER	1	1	1
⊙ 44	302HS31390	2HS31390	GEAR Z27R FREE 2	1	1	1
45	302LZ31040	2LZ31040	SPRING FREE DRUM	1	1	1
46	302HS31041	2HS31041	PLATE GEAR DRIVE	1	1	1
⊙ 47	302HS31250	2HS31250	GEAR Z54R-Z24R	1	1	1
⊙ 48	302HS31070	2HS31070	GEAR Z42R FREE 2	1	1	1
⊙ 49	302HS31110	2HS31110	GEAR Z58L	1	1	1

Ref. No.	Part.No.	Alternative.	Description	Quantity		
				120	230	240
⊙ 50	302H431080	2H431080	GEAR Z64R-Z21L	1	1	1
⊙ 51	302HS31180	2HS31180	GEAR Z44R	1	1	1
⊙ 52	302HS31210	2HS31210	GEAR Z35S FREE	1	1	1
⊙ 53	302HS31220	2HS31220	GEAR Z42R FREE	1	1	1
⊙ 54	302HS31240	2HS31240	GEAR Z32L DRUM	1	1	1
101	7BB200308H	BB105660	+BIND T.T P SCREW 3X8			
102	BAB53060	BAB53060	+TP TAP-TITE S SCREW M3X06			
103	7BB100306H	BB046010	+BIND T.T S SCREW 3X6			
104	7BB200410H	BB105700	+BIND T.T P SCREW 4X10			

- Parts with "*" are component parts or sub-assemblies of the assembly appearing immediately above them.
- Parts with "⊙" indicate regular maintenance parts.

- Parts with "••" are component parts or sub-assembly with "•" appearing immediately above them.

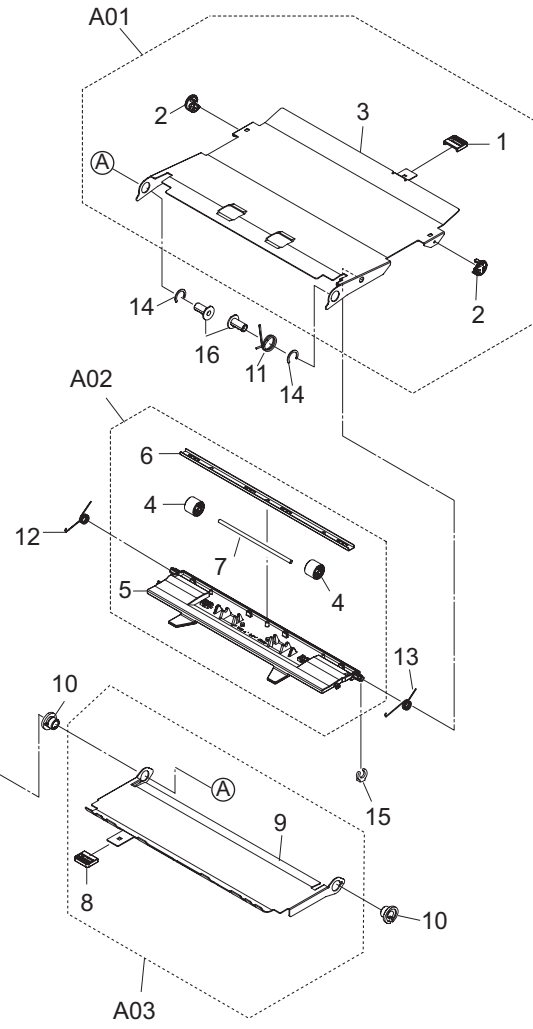
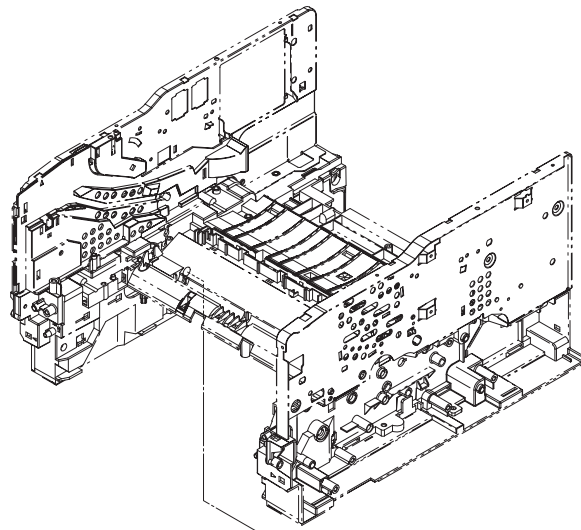
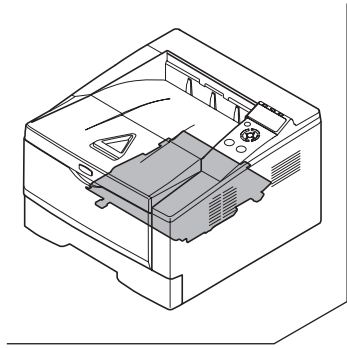

FIG. 10 Duplex Section

	Ref. No.	Part.No.	Alternative.	Description	Quantity		
					120	230	240
⊙	A01	302HS94320	2HS94320	PARTS PLATE COVER DU B ASSY SP	1	1	1
	1	*2FM02690	5MVX221DG002	LEVER DU /B-11 DU A3	1	1	1
	2	*2FM21050	5MVX173DN001	COLLER DU /B-11 DU A3	2	2	2
	3	*302HS29020	2HS29020	PLATE COVER DU B	1	1	1
⊙	A02	302FM94060	2FM94060	PARTS HOLDER DU ASSY SP	1	1	1
⊙	4	*2FM02210	5MVM274DN002	PULLEY MID /B-11 FRAME A4	2	2	2
	5	*2FM21010	5MVX861XB001	HOLDER DU /B-11 DU A1	1	1	1
	6	*2FM21020	5MML821SD009	STAY DU /B-11 DU A3	1	1	1
	7	*302FM02421	2FM02421	SHAFT PULLEY /B-11 FRAME A4	1	1	1
⊙	A03	302HS94330	2HS94330	PARTS PLATE COVER DU ASSY SP	1	1	1
	8	*2FM02690	5MVX221DG002	LEVER DU /B-11 DU A3	1	1	1
	9	*302HS29010	2HS29010	PLATE COVER DU	1	1	1
	10	2FM02140	5MVM786XB001	BUSH DU /B-11 FRAME A3	2	2	2
	11	2FM02500	5MMW176SD002	SPRING DU R /B-11 FRAME A4	1	1	1
	12	2FM02510	5MMW166SD002	SPRING HOLDER L /B-11 FRAME A4	1	1	1
	13	2FM02520	5MMW166SD003	SPRING HOLDER R /B-11 FRAME A4	1	1	1
	14	5MBCK9560XSC	D4103700	C STOP RING /X9.5 X 0.6T S-CR	2	2	2
⊙	15	5MVX111DN003	2A806250	RING STOPPER /A-49 FEED A4	1	1	1
	16	2FM21030	5MVM276DN017	STOPPER BUSH /B-11 DU A4	2	2	2

- Parts with "*" are component parts or sub-assemblies of the assembly appearing immediately above them.
- Parts with "⊙" indicate regular maintenance parts.

- Parts with "••" are component parts or sub-assembly with "•" appearing immediately above them.

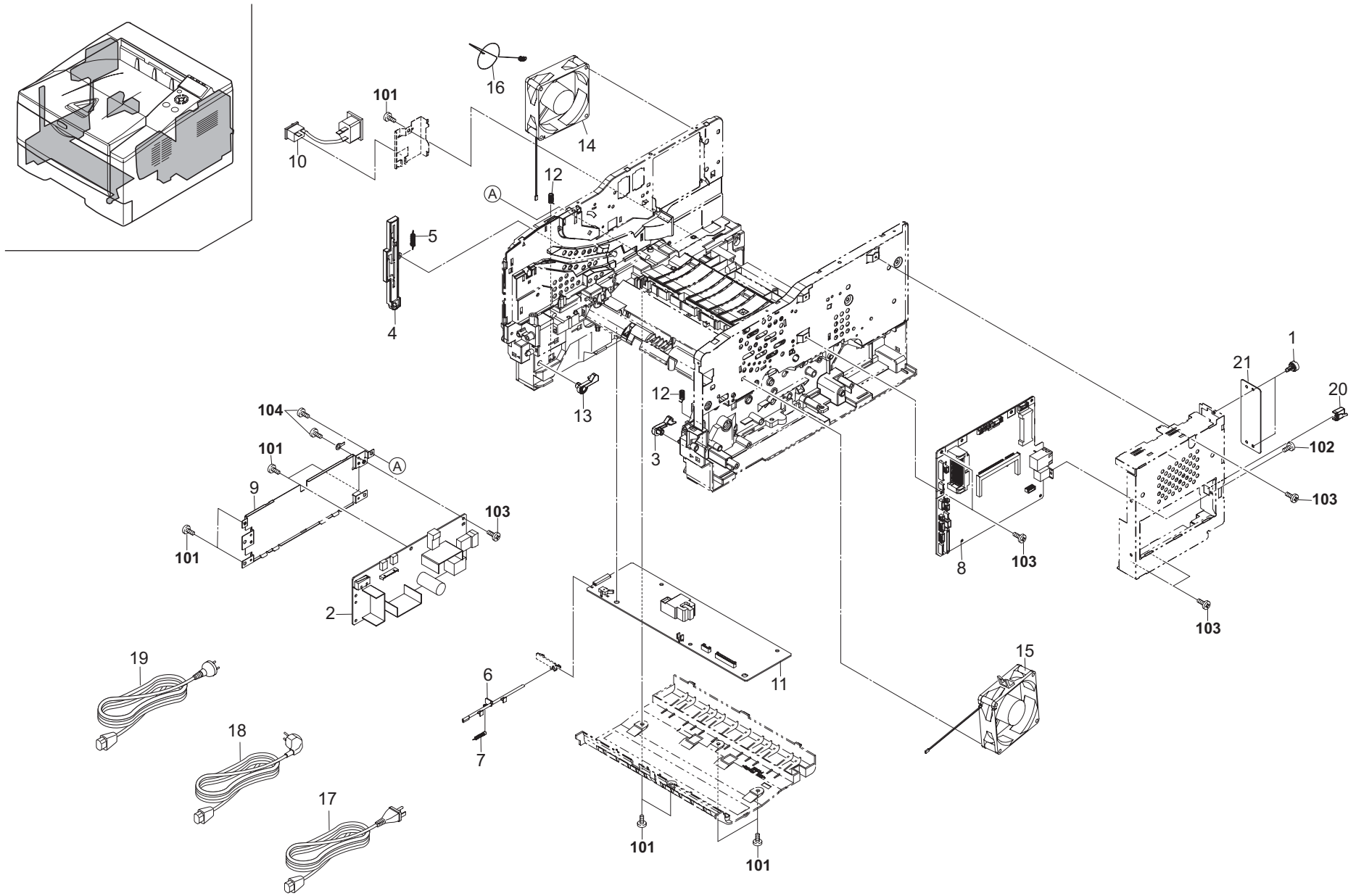

FIG. 11 Electrical Components

2L0

Ref. No.	Part.No.	Alternative.	Description	Quantity		
				120	230	240
1	302F939081	2F939081	SCREW BOX	2	2	2
⊙ 2	302HS45011	2HS45011	SWITCHING REGULATOR 230V		1	1
⊙ 2	302HS45020	2HS45020	SWITCHING REGULATOR 120V	1		
⊙ 3	302HS02070	2HS02070	LEVER LOCK CASSETTE	1	1	1
⊙ 4	302HS02110	2HS02110	LEVER INTERLOCK SW	1	1	1
5	302HS02120	2HS02120	SPRING INTERLOCK SW	1	1	1
⊙ 6	302HS02180	2HS02180	PIN CASSETTE	1	1	1
7	302HS02190	2HS02190	SPRING PIN CASSETTE	1	1	1
⊙ 8	302L094010	2L094010	PARTS PWB CONTROL SP	1	1	1
⊙ 9	302HS02210	2HS02210	PLATE POWER SUPPLY	1	1	1
10	302HS46120	2HS46120	CONN.CORD ASSY PWS-INLET S03238	1	1	1
⊙ 11	302LZ94040	2LZ94040	PARTS HIGH VOLTAGE UNIT SP	1	1	1
12	302HS02360	2HS02360	SPRING LOCK CASSETTE	2	2	2
⊙ 13	302HS02390	2HS02390	LEVER LOCK CASSETTE L	1	1	1
⊙ 14	302LZ94030	2LZ94030	PARTS MOTOR FAN 80 SP	1	1	1
⊙ 15	302L094070	2L094070	PARTS MOTOR FAN 80 ASSY SP	1	1	1
16	302HS02620	2HS02620	SPRING EARTH FAN	1	1	1
17	7AAACCUS+10H001	AA068380	AC CORD ASSY US	1		
18	302FV45020	2FV45020	AC CORD ASSY		1	
19	302FV45040	2FV45040	AC CORD ASSY			1
20	302F939090	2F939090	CAP NETWORK	1	1	1
21	302HS39040	2HS39040	PLATE OPTION	1	1	1

Ref. No.	Part.No.	Alternative.	Description	Quantity		
				120	230	240
101	7BB200410H	BB105700	+BIND T.T P SCREW 4X10			
102	5MBSPB3006NW++R	B1B03060	BIND HEAD SCREW(+)/ M3 X 6 CRFREE			
103	7BB100306H1	BB105820	+BIND T.T S SCREW 3X6			
104	5MBTPB4006TW++R	B1A54060	BIND T.T SCREW(+)/ M4 X 6 CRFREE S-T			

- Parts with "*" are component parts or sub-assemblies of the assembly appearing immediately above them.
- Parts with "⊙" indicate regular maintenance parts.

- Parts with "••" are component parts or sub-assembly with "•" appearing immediately above them.

FIG. 12 Maintenance Kits

Ref. No.	Part.No.	Alternative.	Description	Quantity		
				120	230	240
	1702LZ7US0	072LZ7US	MK-172/MAINTENANCE KIT (OPTION) •DV-172(U) •DK-170	1 1 1		
	1702LZ8AS0	072LZ8AS	MK-174/MAINTENANCE KIT (OPTION) •DV-174(AO) •DK-170			1 1 1
	1702LZ8NL0	072LZ8NL	MK-170/MAINTENANCE KIT (OPTION) •DV-170(E) •DK-170	1 1 1		

- Parts with "•" are component parts or sub-assemblies of the assembly appearing immediately above them.
- Parts with "⊙" indicate regular maintenance parts.

- Parts with "• •" are component parts or sub-assembly with "•" appearing immediately above them.

INDEX

2L0

	Part.No.	Alternative.	Description	Fig.No.
	1702LZ7US0	072LZ7US	MK-172/MAINTENANCE KIT	12
	1702LZ8AS0	072LZ8AS	MK-174/MAINTENANCE KIT	12
	1702LZ8NL0	072LZ8NL	MK-170/MAINTENANCE KIT	12
⊙	2BL06380	2BL06380	GEAR Z25 JOINT	5
	2FM02140	5MVM786XB001	BUSH DU /B-11 FRAME A3	10
	2FM02180	5MVX221DN020	BUSH REGIST C /B-11 FRAME A3	4
⊙	2FM02210	5MVM274DN002	PULLEY MID /B-11 FRAME A4	10
⊙	2FM02350	5MVG133DN022	GEAR Z22 /B-11 FRAME A4	5
	2FM02500	5MMW176SD002	SPRING DU R /B-11 FRAME A4	10
	2FM02510	5MMW166SD002	SPRING HOLDER L /B-11 FRAME A4	10
	2FM02520	5MMW166SD003	SPRING HOLDER R /B-11 FRAME A4	10
	2FM02690	5MVX221DG002	LEVER DU /B-11 DU A3	10
	2FM06010	5MVX765SH004	GUIDE SIDE L /B-11 CASSETTE A2	3
	2FM06020	5MVX765SH005	GUIDE SIDE R /B-11 CASSETTE A2	3
	2FM21010	5MVX861XB001	HOLDER DU /B-11 DU A1	10
	2FM21020	5MML821SD009	STAY DU /B-11 DU A3	10
	2FM21030	5MVM276DN017	STOPPER BUSH /B-11 DU A4	10
	2FM21050	5MVX173DN001	COLLER DU /B-11 DU A3	10
⊙	302A816031	2A816031	BUSH TC R /A-49 FEED A4	4
⊙	302BR06521	2BR06521	RETARD ROLL ASSY /43487V0005 A4	3
	302F902420	2F902420	LOCK COVER TOP R	2
	302F904120	2F904120	EMBLEM KYOCERA	1
	302F904130	2F904130	TAPE EMBLEM	1
	302F906170	2F906170	JOINT PICKUP A	4
	302F906180	2F906180	JOINT PICKUP B	4
	302F906230	2F906230	PULLEY FEED ASSY	4
	302F906240	2F906240	PULLEY PICKUP ASSY	4
	302F906272	2F906272	SHAFT FEED L	4
	302F906280	2F906280	GEAR FEED Z30H	4
	302F908200	2F908200	LOCK COVER	2,5
	302F908270	2F908270	SP BOTTOM MPF L	2
	302F908310	2F908310	PAD FRICTION MPF	2
	302F909031	2F909031	LEVER BASE CAS REAR	3
	302F909040	2F909040	SPRING BASE CAS REAR	3
	302F909210	2F909210	PAD BOTTOM	3
	302F929140	2F929140	BUSH DU	5,9
	302F931350	2F931350	JOINT SHAFT CASSETTE	9
	302F931490	2F931490	BUSH FEED DRIVE	9
	302F939081	2F939081	SCREW BOX	11
	302F939090	2F939090	CAP NETWORK	11
	302FM02421	2FM02421	SHAFT PULLEY /B-11 FRAME A4	10
⊙	302FM94020	2FM94020	GEAR CLUTCH ASSY A SP	5
⊙	302FM94030	2FM94030	GEAR CLUTCH ASSY B SP	5
⊙	302FM94060	2FM94060	PARTS HOLDER DU ASSY SP	10
	302FV45020	2FV45020	AC CORD ASSY	11
	302FV45040	2FV45040	AC CORD ASSY	11
	302H402040	2H402040	SPRING REG GND	2
	302H402060	2H402060	SPRING EARTH DU FEED	2
	302H405010	2H405010	BUTTON A	1
	302H405020	2H405020	BUTTON B	1

	Part.No.	Alternative.	Description	Fig.No.
	302H405030	2H405030	BUTTON C	1
	302H405040	2H405040	BUTTON D	1
	302H405080	2H405080	SHEET BUTTON	1
	302H405110	2H405110	LENS LED	1
⊙	302H428020	2H428020	DISCHARGER FD	5
	302H431010	2H431010	HOLDER DRIVE	9
	302H431020	2H431020	COVER HOLDER DRIVE	9
⊙	302H431030	2H431030	GEAR Z42R	9
⊙	302H431040	2H431040	GEAR Z34L-Z24L	9
	302H431050	2H431050	PIN HOLDER A	9
	302H431060	2H431060	PIN HOLDER B	9
	302H431070	2H431070	BUSH DRIVE 6	9
⊙	302H431080	2H431080	GEAR Z64R-Z21L	9
	302H446020	2H446020	CONN.CORD ASSY LCD-RELAY S03394	1
⊙	302H493040	2H493040	DR-150	9
⊙	302H494010	2H494010	COVER TOP B(N) KIT SP	1
⊙	302H494070	2H494070	SOLENOID ASSY SP	5
⊙	302H494080	2H494080	HOLDER DC BRUSH ASSY	4
⊙	302H994360	2H994360	PARTS FULL SENSOR ASSY SP	2
	302HN09190	2HN09190	SPRING FIX	3
	302HN29050	2HN29050	BUSH DU	5
⊙	302HN44111	2HN44111	CLUTCH FEED	9
	302HS01130	2HS01130	P.W.B RFID WITH SOFTWARE	4
⊙	302HS02070	2HS02070	LEVER LOCK CASSETTE	11
⊙	302HS02090	2HS02090	LEVER STOPPER DLP	2
	302HS02100	2HS02100	SPRING STOPPER DLP	2
⊙	302HS02110	2HS02110	LEVER INTERLOCK SW	11
	302HS02120	2HS02120	SPRING INTERLOCK SW	11
	302HS02160	2HS02160	SPRING MC	2
⊙	302HS02180	2HS02180	PIN CASSETTE	11
	302HS02190	2HS02190	SPRING PIN CASSETTE	11
⊙	302HS02210	2HS02210	PLATE POWER SUPPLY	11
	302HS02260	2HS02260	SPRING EARTH REG LOW	4
	302HS02330	2HS02330	SPRING EARTH DU PLATE	2
	302HS02340	2HS02340	SPRING EARTH RIGHT	4
	302HS02360	2HS02360	SPRING LOCK CASSETTE	11
	302HS02370	2HS02370	SPRING EARTH CASSETTE	9
⊙	302HS02381	2HS02381	PLATE PF CONNECTOR	9
	302HS02390	2HS02390	LEVER LOCK CASSETTE L	11
	302HS02410	2HS02410	SPRING EARTH DU MID	4
	302HS02440	2HS02440	SPRING EARTH DLP PLATE	4
	302HS02470	2HS02470	SPRING PIN BIAS	2
	302HS02620	2HS02620	SPRING EARTH FAN	11
⊙	302HS02650	2HS02650	HOOK PF	2
⊙	302HS02700	2HS02700	SHEET BUSH DU	2
⊙	302HS04070	2HS04070	COVER RACK	1
⊙	302HS04160	2HS04160	COVER RACK B	1
	302HS04170	2HS04170	SHEET TOP COVER	1
	302HS06010	2HS06010	FRAME FEED	4
	302HS06020	2HS06020	HOLDER FEED	4

• Parts with "⊙" indicate regular maintenance parts.

	Part.No.	Alternative.	Description	Fig.No.		Part.No.	Alternative.	Description	Fig.No.
	302HS06050	2HS06050	PULLEY FEED	4	⊙	302HS28030	2HS28030	ROLLER FD UP	5
⊙	302HS06060	2HS06060	ACTUATOR EMPTY A	4		302HS28041	2HS28041	COVER FD	5
⊙	302HS06071	2HS06071	ACTUATOR EMPTY B	4	⊙	302HS28060	2HS28060	GEAR Z21S	5
⊙	302HS06090	2HS06090	GEAR Z22S FEED	4		302HS28070	2HS28070	PULLEY EXIT	5
	302HS06120	2HS06120	SPRING ACTUATOR	4		302HS28110	2HS28110	SPRING EARTH	5
	302HS06130	2HS06130	SPRING PULLEY	4		302HS28120	2HS28120	SPRING EXIT	5
	302HS08011	2HS08011	FRAME MPF	4		302HS28141	2HS28141	SPRING PULLEY	5
	302HS08050	2HS08050	BASE MPF	2	⊙	302HS28170	2HS28170	GEAR FD Z29S	5
	302HS08080	2HS08080	SHAFT FEED MPF	4		302HS29010	2HS29010	PLATE COVER DU	10
	302HS08100	2HS08100	BRACKET BOTTOM	2		302HS29020	2HS29020	PLATE COVER DU B	10
⊙	302HS08110	2HS08110	ACTUATOR MPF	4		302HS31041	2HS31041	PLATE GEAR DRIVE	9
⊙	302HS08160	2HS08160	GEAR Z20S MPF	4		302HS31050	2HS31050	LEVER LIFT BOTTOM	9
	302HS08170	2HS08170	SPRING SEPARATOR	2	⊙	302HS31070	2HS31070	GEAR Z42R FREE 2	9
	302HS08190	2HS08190	SPRING ACTUATOR	4	⊙	302HS31090	2HS31090	GEAR Z37L FREE	9
	302HS08210	2HS08210	SPRING EARTH MPF	2	⊙	302HS31100	2HS31100	GEAR Z20L CLUTCH	9
	302HS08230	2HS08230	PLATE EARTH BOTTOM	2	⊙	302HS31110	2HS31110	GEAR Z58L	9
	302HS08241	2HS08241	GUIDE MPF R	2	⊙	302HS31120	2HS31120	GEAR Z27L CLUTCH	9
	302HS08251	2HS08251	GUIDE MPF L	2	⊙	302HS31130	2HS31130	GEAR Z45R CLUTCH	9
⊙	302HS08260	2HS08260	ROLLER M/P ASSY	4	⊙	302HS31140	2HS31140	GEAR Z35R IDLE	9
	302HS08270	2HS08270	SPRING BRACKET	2	⊙	302HS31150	2HS31150	GEAR Z31L-Z14S	9
	302HS08320	2HS08320	SPRING COVER MPF	2,5	⊙	302HS31180	2HS31180	GEAR Z44R	9
	302HS08340	2HS08340	COVER REG SW	4	⊙	302HS31190	2HS31190	GEAR Z17R FREE	9
	302HS08351	2HS08351	SPRING COVER REG	4	⊙	302HS31200	2HS31200	GEAR Z26L FREE	9
	302HS09070	2HS09070	PAPER INDICATOR	3	⊙	302HS31210	2HS31210	GEAR Z35S FREE	9
	302HS09081	2HS09081	CURSOR END	3	⊙	302HS31220	2HS31220	GEAR Z42R FREE	9
	302HS09100	2HS09100	LOCK BOTTOM	3	⊙	302HS31230	2HS31230	GEAR Z38S MPF	9
	302HS09120	2HS09120	SPRING BOTTOM L	3	⊙	302HS31240	2HS31240	GEAR Z32L DRUM	9
	302HS09130	2HS09130	SPRING BOTTOM R	3	⊙	302HS31250	2HS31250	GEAR Z54R-Z24R	9
	302HS09140	2HS09140	SPRING LOCK BOTTOM	3	⊙	302HS31260	2HS31260	GEAR Z32R	9
	302HS09160	2HS09160	GEAR CASSETTE	3		302HS31281	2HS31281	LIFT BOTTOM	9
	302HS09180	2HS09180	SPRING RETARD	3		302HS31310	2HS31310	SPRING FREE FUSER	9
	302HS09260	2HS09260	HOLDER RETARD	3		302HS31320	2HS31320	SPRING FREE MAG	9
	302HS24070	2HS24070	SPRING ACTUATOR REG	2		302HS31330	2HS31330	PIN CLUTCH	9
	302HS24120	2HS24120	BUSH REGIST	4		302HS31340	2HS31340	SHAFT CASSETTE	9
	302HS24130	2HS24130	BUSH 4 DU ROLL	2		302HS31360	2HS31360	PIN HOLDER A	9
	302HS24140	2HS24140	BUSH 6 EW	4		302HS31370	2HS31370	PIN HOLDER B	9
⊙	302HS24160	2HS24160	ROLLER DU	2		302HS31380	2HS31380	SPRING LIFT BOTTOM	9
	302HS24181	2HS24181	SHEET REGIST	4	⊙	302HS31390	2HS31390	GEAR Z27R FREE 2	9
⊙	302HS24190	2HS24190	GEAR Z14R REG UP	4		302HS31410	2HS31410	SPRING FREE Z37L	9
⊙	302HS24200	2HS24200	GEAR Z21L-Z23L REG LOW	4		302HS31420	2HS31420	EARTH PLATE DRIVE	9
⊙	302HS24220	2HS24220	GEAR Z25R DU FEED	9		302HS31430	2HS31430	POLYSLIDER 9.5	9
⊙	302HS24230	2HS24230	GEAR Z26L DU MID	9		302HS31440	2HS31440	SPRING FEED	9
⊙	302HS24250	2HS24250	BUSH TC R	4		302HS34080	2HS34080	LABEL JAM TK OPERATION	1
	302HS24280	2HS24280	SPRING RELEASE TC L	4		302HS39040	2HS39040	PLATE OPTION	11
	302HS24300	2HS24300	SPRING CONTACT TC	2	⊙	302HS44020	2HS44020	SOLENOID MPF	9
	302HS24310	2HS24310	SPRING EARTH BRUSH	4	⊙	302HS45011	2HS45011	SWITCHING REGULATOR 230V	11
	302HS24360	2HS24360	SPRING REGIST C	4	⊙	302HS45020	2HS45020	SWITCHING REGULATOR 120V	11
	302HS24400	2HS24400	SPRING TC R	4		302HS46120	2HS46120	CONN.CORD ASSY PWS-INLET S03238	11
	302HS24410	2HS24410	ROLLER REGIST LOW	4	⊙	302HS93070	2HS93070	MC-130	6
	302HS24460	2HS24460	BUSH REGIST R	4	⊙	302HS94000	2HS94000	PLATE BOTTOM ASSY	3

• Parts with "⊙" indicate regular maintenance parts.

	Part.No.	Alternative.	Description	Fig.No.		Part.No.	Alternative.	Description	Fig.No.
⊙	302HS94020	2HS94020	LID TOP ASSY	1		5MVG137DN032	2A806720	GEAR MPF /A-49 MPF A4	2
⊙	302HS94032	2HS94032	HOLDER FEED ASSY	4		5MVM273DB005	2A820100	PULLEY EXIT /A-49 FUSER A3	4,5
⊙	302HS94040	2HS94040	SEPARATOR MPF ASSY	2	⊙	5MVX111DN003	2A806250	RING STOPPER /A-49 FEED A4	4,9,10
⊙	302HS94050	2HS94050	PLATE BOTTOM MPF ASSY	2		5MVX111DN007	2BT11070	STOPPER 3 /2BT1107 A4	5
⊙	302HS94081	2HS94081	REGIST LOW KIT	4	⊙	5MVX431DN005	2FV02100	LEVER LOCK DLP	4
⊙	302HS94121	2HS94121	COVER FRONT ASSY (2HS) SP	1		5MVX541DG002	2A807191	LEVER REAR /A-49 CASSETTE A3	3
⊙	302HS94150	2HS94150	EMPTY SENSOR KIT SP	4		5MVX541DG003	2A807161	LEVER SIDE /A-49 CASSETTE A3	3
⊙	302HS94160	2HS94160	COVER REAR ASSY SP	5		7AAACCUS+10H001	AA068380	AC CORD ASSY US	11
⊙	302HS94320	2HS94320	PARTS PLATE COVER DU B ASSY SP	10		7BC06062C020H01	BC045240	POLY SLIDER WASHER M6.2X12X0.2T	9
⊙	302HS94330	2HS94330	PARTS PLATE COVER DU ASSY SP	10		7BC460529080H01	BC059590	CUT WASHER 5.2X9.0X0.8T(BLACK)	4
⊙	302J002010	2J002010	FOOT	2		7NXSG2481+++H01	NX052600	SENSOR OPT.	4
⊙	302L000010	2L000010	COVER RIGHT ASSY	1		7RHA2H10701+H01	RH043740	M.GLAZE R. 100MJ 1/2W	2
	302L004010	2L004010	COVER RIGHT	1		7YBEJ0J0D001H01	YB045400	FERRITE CORE	1
⊙	302L094010	2L094010	PARTS PWB CONTROL SP	11		7YZM420002++H01	YZ045260	ACCESS.BAND	1
⊙	302L094030	2L094030	PARTS COVER TOP ASSY SP	1		M2107250	M2107250	BAND,RSG-100(KITAGAWA)	9
⊙	302L094050	2L094050	PARTS PWB LCD SP	1					
⊙	302L094070	2L094070	PARTS MOTOR FAN 80 ASSY SP	11					
⊙	302LZ02100	2LZ02100	SPRING EARTH REG UP	4					
⊙	302LZ04010	2LZ04010	COVER LEFT	1					
	302LZ04030	2LZ04030	COVER DIMM	1					
	302LZ08020	2LZ08020	GUIDE TURN MPF	2					
	302LZ09030	2LZ09030	GUIDE RETARD	3					
⊙	302LZ24010	2LZ24010	GEAR Z17L TC	4					
	302LZ24030	2LZ24030	ACTUATOR REGIST	2					
	302LZ24090	2LZ24090	SPRING TC L	4					
⊙	302LZ24110	2LZ24110	SPRING REGIST RB	4					
⊙	302LZ24120	2LZ24120	SPRING REGIST LB	4					
	302LZ31040	2LZ31040	SPRING FREE DRUM	9					
⊙	302LZ93010	2LZ93010	DV-170(E)	7					
⊙	302LZ93020	2LZ93020	DV-172(U)	7					
⊙	302LZ93030	2LZ93030	LK-170	2					
⊙	302LZ93040	2LZ93040	FK-170(E)	8					
⊙	302LZ93050	2LZ93050	FK-170(U)	8					
⊙	302LZ93060	2LZ93060	DK-170	6					
⊙	302LZ93070	2LZ93070	CT-170	3					
⊙	302LZ93080	2LZ93080	DV-174(AO)	7					
⊙	302LZ94010	2LZ94010	PARTS PWB ERASER SP	2					
⊙	302LZ94020	2LZ94020	PARTS MOTOR ASSY SP	9					
⊙	302LZ94030	2LZ94030	PARTS MOTOR FAN 80 SP	11					
⊙	302LZ94040	2LZ94040	PARTS HIGH VOLTAGE UNIT SP	11					
⊙	302LZ94050	2LZ94050	PARTS ROLLER REGIST UP SP	4					
⊙	302LZ94060	2LZ94060	PARTS ROLLER TRANSFER E SP	4					
⊙	302LZ94070	2LZ94070	PARTS ROLLER TRANSFER A SP	4					
⊙	302LZ94090	2LZ94090	PARTS TRAY MPF ASSY SP	2					
⊙	302LZ94100	2LZ94100	PARTS FD ASSY (2LZ) SP	5					
	5MBCK9560XSC	D4103700	C STOP RING /X9.5 X 0.6T S-CR	10					
	5MMW171LD006	2A807530	SPRING STOPPER /A49 CASSETTE A4	3					
	5MMW261LD036	2A814570	SPRING TE SENSOR /A-49 DLP A4	4					
	5MMW261LD067	2FV02270	SPRING LEVER LOCK L	4					
	5MMW261LD068	2FV02280	SPRING LEVER LOCK R	4					

• Parts with "⊙" indicate regular maintenance parts.

KYOCERA MITA EUROPE B.V.

Hoeksteen 40, 2132 MS Hoofddorp,
The Netherlands
Phone: +31.20.654.0000
Home page: <http://www.kyoceramita-europe.com>
Email: info@kyoceramita-europe.com

KYOCERA MITA NEDERLAND B.V.
Beechavenue 25, 1119RA Schiphol-Rijk
The Netherlands
Phone: +31.20.58.77.200

KYOCERA MITA (UK) LTD
8 Beacontree Plaza
Gillette Way Reading Berks RG2 0BS,
U.K.
Phone: +44.1189.311.500

KYOCERA MITA ITALIA S.p.A.
Via G. Verdi, 89 / 91, 20063 Cernusco s/N
Milano, Italy
Phone: +39.02.92179.1

S.A. KYOCERA MITA BELGIUM N.V.
Hermestraat 8A, 1930 Zaventem,
Belgium
Phone: +32.2.720.9270

KYOCERA MITA FRANCE S.A.
Parc Les Algorithmes Saint Aubin
91194 GIF-SUR-YVETTE,
France
Phone: +33.1.6985.2600

KYOCERA MITA ESPAÑA S.A.
Edificio Kyocera, Avda de Manacor No. 2,
28290 Las Matas (Madrid),
Spain
Phone: +34.91.631.8392

KYOCERA MITA FINLAND OY
Kirvesmiehenkatu 4, 00880 Helsinki,
Finland
Phone: +358.9.4780.5200

KYOCERA MITA (SCHWEIZ)
Hohlstrasse 614, 8048 Zürich
Switzerland
Phone: +41.1.908.4949

KYOCERA MITA DEUTSCHLAND GMBH
Otto-Hahn-Str. 12 D-40670 Meerbusch,
Germany
Phone: +49.2159.918.0

KYOCERA MITA GMBH AUSTRIA
Eduard-Kittenberger-Gasse 95,
1230 Wien,
Austria
Phone: +43.1.86338.210

KYOCERA MITA SVENSKA AB
Esbogatan 16B 164 75 Kista,
Sweden
Phone: +46.8.546.55000

KYOCERA MITA NORGE
Postboks 150 Oppsal, NO 0619 Oslo
Olaf Helsetsvei 6, NO 0694 Oslo,
Norway
Phone: +47.22.62.73.00

KYOCERA MITA DANMARK A/S
Ejby Industrivej 1, DK-2600 Glostrup,
Denmark
Phone: +45.5687.1100

KYOCERA MITA PORTUGAL LDA.
Rua do Centro Cultural, 41 (Alvalade) 1700-106 Lisbon,
Portugal
Phone: +351.21.842.9100

KYOCERA MITA SOUTH AFRICA (PTY) LTD.
527 Kyalami Boulevard,
Kyalami Business Park Midrand,
South Africa
Phone: +27.(0)11.540.2600

KYOCERA MITA AMERICA, INC.

Headquarters:
225 Sand Road,
Fairfield, New Jersey 07004-0008,
U.S.A.
Phone: (973) 808-8444

KYOCERA MITA AUSTRALIA PTY. LTD.
Level 3, 6-10 Talavera Road, North Ryde,
N.S.W. 2113 Australia
Phone: (02) 9888-9999

KYOCERA MITA NEW ZEALAND LTD.
1-3 Parkhead Place, Albany
P.O. Box 302 125 NHPC, Auckland,
New Zealand
Phone: (09) 415-4517

KYOCERA MITA (THAILAND) CORP., LTD.
9/209 Ratchada-Prachachem Road,
Bang Sue, Bangkok 10800, Thailand
Phone: (02) 586-0320

KYOCERA MITA SINGAPORE PTE LTD.
121 Genting Lane, 3rd Level,
Singapore 349572
Phone: 67418733

KYOCERA MITA HONG KONG LIMITED
11/F., Mita Centre,
552-566, Castle Peak Road,
Tsuen Wan, New Territories,
Hong Kong
Phone: 24297422

KYOCERA MITA TAIWAN Corporation.
7F-1~2, No.41, Lane 221, Gangchi Rd.
Neihu District, Taipei, Taiwan, 114. R.O.C.
Phone: (02) 87511560

KYOCERA MITA Corporation

2-28, 1-chome, Tamatsukuri, Chuo-ku
Osaka 540-8585, Japan
Phone: (06) 6764-3555
<http://www.kyoceramita.com>

KYOCERA MITA AMERICA, INC.

Headquarters:

225 Sand Road,
Fairfield, New Jersey 07004-0008
TEL : (973) 808-8444
FAX : (973) 882-6000

New York Branch:

1410 Broadway 23rd floor
New York, NY 10018
TEL : (917) 286-5400
FAX : (917) 286-5402

Northeastern Region:

225 Sand Road,
Fairfield, New Jersey 07004-0008
TEL : (973) 808-8444
FAX : (973) 882-4401

Midwestern Region:

201 Hansen Court Suite 119
Wood Dale, Illinois 60191
TEL : (630) 238-9982
FAX : (630) 238-9487

Western Region:

14101 Alton Parkway,
Irvine, California 92618-7006
TEL : (949) 457-9000
FAX : (949) 457-9119

Southeastern Region:

1500 Oakbrook Drive,
Norcross, Georgia 30093
TEL : (770) 729-9786
FAX : (770) 729-9873

Southwestern Region:

2825 West Story Road,
Irving, Texas 75038-5299
TEL : (972) 550-8987
FAX : (972) 252-9786

National Operation Center & National Training Center:

2825 West Story Road,
Irving, Texas 75038-5299
TEL : (972) 659-0055
FAX : (972) 570-5816

Latin America Division:

8240 N.W. 52nd. Terrace Dawson Building,
Suite 108 Miami, Florida 33166
TEL : (305) 421-6640
FAX : (305) 421-6666

KYOCERA MITA CANADA, LTD.

6120 Kestrel Road, Mississauga,
Ontario L5T 1S8, Canada
TEL : (905) 670-4425
FAX : (905) 670-8116

KYOCERA MITA MEXICO, S.A. DE C.V.

Av. 16 de Septiembre #407
Col. Santa Inés,
Azcapotzalco México,
D.F. 02130, México
TEL : (55) 5383-2741
FAX : (55) 5383-7804

©2010 KYOCERA MITA Corporation

<http://www.kyoceramita.com>

 **KYOCERA** is a trademark of Kyocera Corporation

Printed in U.S.A.



PF-100

PARTS LIST

Published in March 2010
Rev.4

NOTES

1. Indicate parts number and parts description together with the machine model name when placing an order.

e.g.	Parts Number	Parts Name	Machine Model	Quantity
	303LF02010	BASE	PF-100	1

2. Symbols in the "Parts Number" column.

- Parts with "*" are component parts or sub-assemblies of the assembly appearing immediately above them.

e.g.	Parts Number	Parts Name	Parts Number	Parts Name
	3303LF94010	BRACKET FEED ASSY SP	• 302GJ06490	GEAR PICKUP ASSY
			• 302GJ06500	ROLLER FEED ASSY

- Parts with "⊙" indicate regular maintenance parts.

—— CONTENTS ——

FIG. 1	Paper Feed Section 1	2
FIG. 2	Paper Feed Section 2	4
	• INDEX	6

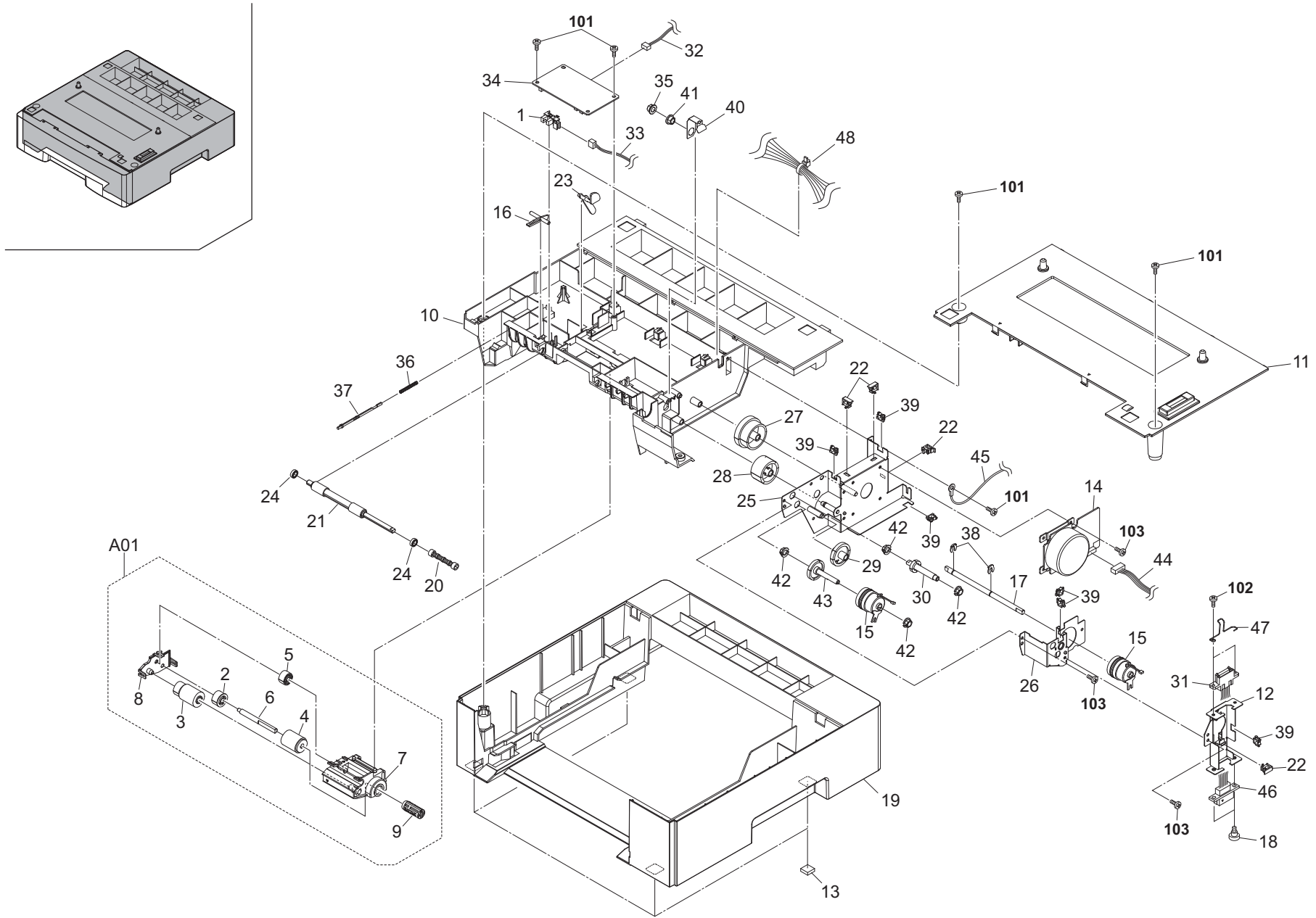

FIG. 1 Paper Feed Section 1

3LF-4

Ref. No.	Part.No.	Alternative.	Description	Quantity			Ref. No.	Part.No.	Alternative.	Description	Quantity			
				120	230	240					120	230	240	
⊙	1	7NXSG2481+++H01	NX052600	SENSOR OPT.	1	1	1	101	7BB200308H	BB105660	+BIND T.T P SCREW 3X8			
⊙	A01	303LF94010	3LF94010	BRACKET FEED ASSY SP	1	1	1	102	7BB100308H1	BB112120	+BIND T.T S SCREW 3X8			
⊙	2	*302GJ06490	2GJ06490	GEAR PICKUP ASSY	1	1	1	103	7BB100306H1	BB105820	+BIND T.T S SCREW 3X6			
⊙	3	*302GJ06500	2GJ06500	ROLLER FEED ASSY	1	1	1							
⊙	4	*302GJ06510	2GJ06510	ROLLER PICKUP ASSY	1	1	1							
⊙	5	*302GJ06560	2GJ06560	GEAR FEED IDLE Z29S	1	1	1							
	6	*302GJ06600	2GJ06600	SHAFT PICKUP	1	1	1							
	7	*303J806010	3J806010	BRACKET FEED	1	1	1							
	8	*303J806020	3J806020	COVER FEED	1	1	1							
	9	*303J806080	3J806080	HOLDER RELEASE	1	1	1							
	10	303LF02020	3LF02020	FRAME TOP	1	1	1							
⊙	11	303LF02030	3LF02030	COVER TOP	1	1	1							
	12	303LF02040	3LF02040	MOUNT DRAWER	1	1	1							
	13	302J002010	2J002010	FOOT	4	4	4							
⊙	14	302GJ44090	2GJ44090	MOTOR FEED	1	1	1							
⊙	15	302GJ44110	2GJ44110	CLUTCH REG	2	2	2							
⊙	16	303J806030	3J806030	ACTUATOR	1	1	1							
	17	303LF06010	3LF06010	SHAFT FEED	1	1	1							
	18	302HS02540	2HS02540	PIN DRAWER	2	2	2							
⊙	19	303LF02010	3LF02010	BASE	1	1	1							
	20	303J806090	3J806090	SHAFT MIDDLE C	1	1	1							
⊙	21	303J806100	3J806100	ROLLER MIDDLE ASSY	1	1	1							
	22	7YZM610009+++H01	YZ042980	ACCESS.SADDLE	4	4	4							
⊙	23	5MVX432DB011	3BW06010	ACTUATOR FEEDER PE /A-49 FEEDER A3	1	1	1							
⊙	24	303J806140	3J806140	BEARING 106	2	2	2							
	25	303LF31010	3LF31010	MOUNT MOTOR A	1	1	1							
	26	303LF31020	3LF31020	MOUNT MOTOR B	1	1	1							
⊙	27	303LF31030	3LF31030	GEAR Z64L-Z47S	1	1	1							
⊙	28	303LF31040	3LF31040	GEAR Z36S	1	1	1							
⊙	29	303LF31050	3LF31050	GEAR Z35S	1	1	1							
⊙	30	303LF31060	3LF31060	GEAR Z17S MIDDLE	1	1	1							
⊙	31	303LF46010	3LF46010	CONN.CORD ASSY S03310	1	1	1							
	32	303LF46040	3LF46040	CONN.CORD ASSY S03313	1	1	1							
	33	303LF46020	3LF46020	CONN.CORD ASSY S03311	1	1	1							
⊙	34	303LF01010	3LF01010	P.W.B BOARD ASSY PF CONT WITH SOFTWARE	1	1	1							
⊙	35	302H702590	2H702590	BUSH SCREW	1	1	1							
	36	5MMW341LD005	2A802070	SPRING PIN CASSETTE/A-49 FRAME A4	1	1	1							
	37	5MVT611DW001	3BW02040	PIN FEEDER /A-49 FEEDER A3	1	1	1							
⊙	38	5MVX111DN003	2A806250	RING STOPPER /A-49 FEED A4	2	2	2							
	39	7YZM210006+++H01	YZ038000	ACCESS.EDGING	6	6	6							
	40	303LF06020	3LF06020	PLATE EARTH FEED	1	1	1							
⊙	41	302H024370	2H024370	BUSH 6 EW	1	1	1							
⊙	42	302F931490	2F931490	BUSH FEED DRIVE	4	4	4							
⊙	43	303LF31110	3LF31110	GEAR Z30S CLUTCH	1	1	1							
	44	303LF46030	3LF46030	CONN.CORD ASSY S03312	1	1	1							
	45	303LF46060	3LF46060	CONN.CORD ASSY S03390	1	1	1							
⊙	46	303LF46050	3LF46050	CONN.CORD ASSY S03314	1	1	1							
	47	303LF02111	3LF02111	SPRING EARTH PF	1	1	1							
	48	7YZM420003+++H01	YZ052580	ACCESS.BAND	1	1	1							

- Parts with "*" are component parts or sub-assemblies of the assembly appearing immediately above them.
- Parts with "⊙" indicate regular maintenance parts.

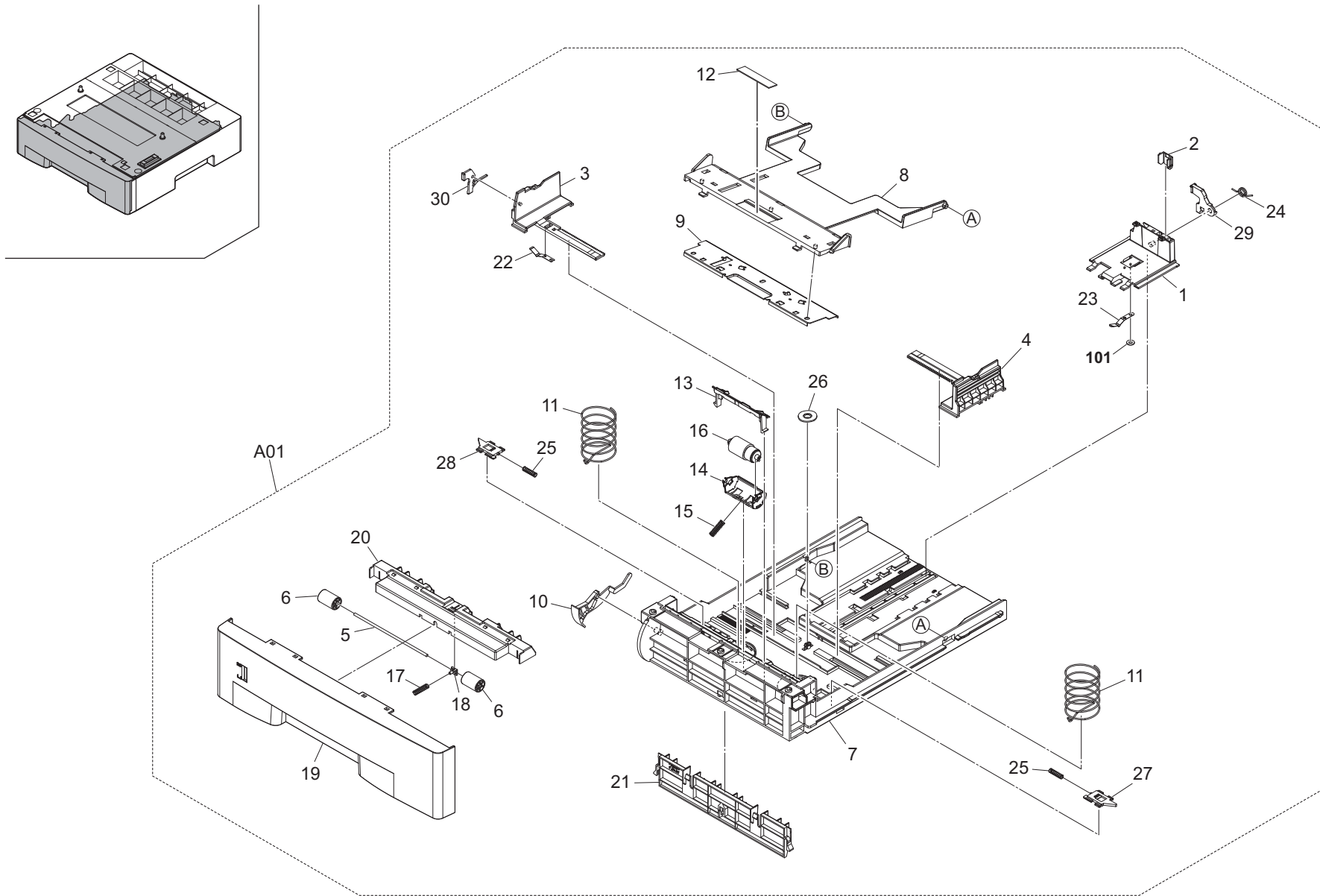

FIG. 2 Paper Feed Section 2

3LF-4

Ref. No.	Part.No.	Alternative.	Description	Quantity			Ref. No.	Part.No.	Alternative.	Description	Quantity		
				120	230	240					120	230	240
⊙ A01	303LF93010	3LF93010	CT-131	1	1	1	101	5MBNPXX20NSB	D4110200	PUSH NUT / 2 S-BZN			
1	*2DC07010	2DC07010	STOPPER PAPER	1	1	1							
2	*2DC07020	2DC07020	POSITIONING FOLIO PAPER	1	1	1							
3	*2FM06010	5MVX765SH004	GUIDE SIDE L /B-11 CASSETTE A2	1	1	1							
4	*2FM06020	5MVX765SH005	GUIDE SIDE R /B-11 CASSETTE A2	1	1	1							
⊙ 5	*302GJ06470	2GJ06470	SHAFT MID MP	1	1	1							
6	*302GJ06480	2GJ06480	PULLEY MID MP	2	2	2							
7	*302GJ09010	2GJ09010	BASE CASSETTE	1	1	1							
8	*302GJ09020	2GJ09020	BOTTOM CASSETTE	1	1	1							
9	*302GJ09030	2GJ09030	PLATE BOTTOM	1	1	1							
⊙ 10	*302GJ09040	2GJ09040	INDICATOR CASSETTE	1	1	1							
⊙ 11	*302GJ09050	2GJ09050	SPRING CASSETTE	2	2	2							
⊙ 12	*302GJ09090	2GJ09090	PAD BOTTOM	1	1	1							
13	*302GJ09111	2GJ09111	GUIDE RETARD	1	1	1							
14	*302GJ09120	2GJ09120	HOLDER RETARD	1	1	1							
15	*302GJ09130	2GJ09130	SPRING RETARD	1	1	1							
⊙ 16	*302GJ09141	2GJ09141	RETARD ROLLER ASSY	1	1	1							
17	*303J806120	3J806120	SPRING FEED	1	1	1							
18	*303J809040	3J809040	STOPPER SPRING FEED	1	1	1							
⊙ 19	*303LF09010	3LF09010	COVER CASSETTE	1	1	1							
20	*303LF09020	3LF09020	HOLDER CASSETTE	1	1	1							
21	*303LF09030	3LF09030	GUIDE CASSETTE	1	1	1							
22	*5MMP141LD002	2A807510	PLATE SIDE GUIDE /A49 CASSETTE A4	1	1	1							
23	*5MMP141LD003	2A807520	PLATE STOPPER /A49 CASSETTE A4	1	1	1							
24	*5MMW171LD006	2A807530	SPRING STOPPER /A49 CASSETTE A4	1	1	1							
25	*5MMW251LD045	2A807140	SPRING LOCK /A-49 CASSETTE A4	2	2	2							
26	*5MVG127DN071	2A807050	GEAR CASSETTE /A-49 CASSETTE A4	1	1	1							
27	*5MVX431DW001	2A807121	LOCK CASSETTE R /A-49 CASSETTE A4	1	1	1							
28	*5MVX431DW002	2A807131	LOCK CASSETTE L /A-49 CASSETTE A4	1	1	1							
29	*5MVX541DG002	2A807191	LEVER REAR /A-49 CASSETTE A3	1	1	1							
30	*5MVX541DG003	2A807161	LEVER SIDE /A-49 CASSETTE A3	1	1	1							

- Parts with "*" are component parts or sub-assemblies of the assembly appearing immediately above them.
- Parts with "⊙" indicate regular maintenance parts.

INDEX

3LF-4

Part.No.	Alternative.	Description	Fig.No.
2DC07010	2DC07010	STOPPER PAPER	2
2DC07020	2DC07020	POSITIONING FOLIO PAPER	2
2FM06010	5MVX765SH004	GUIDE SIDE L /B-11 CASSETTE A2	2
2FM06020	5MVX765SH005	GUIDE SIDE R /B-11 CASSETTE A2	2
⊙ 302F931490	2F931490	BUSH FEED DRIVE	1
⊙ 302GJ06470	2GJ06470	SHAFT MID MP	2
302GJ06480	2GJ06480	PULLEY MID MP	2
⊙ 302GJ06490	2GJ06490	GEAR PICKUP ASSY	1
⊙ 302GJ06500	2GJ06500	ROLLER FEED ASSY	1
⊙ 302GJ06510	2GJ06510	ROLLER PICKUP ASSY	1
⊙ 302GJ06560	2GJ06560	GEAR FEED IDLE Z29S	1
302GJ06600	2GJ06600	SHAFT PICKUP	1
302GJ09010	2GJ09010	BASE CASSETTE	2
302GJ09020	2GJ09020	BOTTOM CASSETTE	2
302GJ09030	2GJ09030	PLATE BOTTOM	2
⊙ 302GJ09040	2GJ09040	INDICATOR CASSETTE	2
⊙ 302GJ09050	2GJ09050	SPRING CASSETTE	2
⊙ 302GJ09090	2GJ09090	PAD BOTTOM	2
302GJ09111	2GJ09111	GUIDE RETARD	2
302GJ09120	2GJ09120	HOLDER RETARD	2
302GJ09130	2GJ09130	SPRING RETARD	2
⊙ 302GJ09141	2GJ09141	RETARD ROLLER ASSY	2
⊙ 302GJ44090	2GJ44090	MOTOR FEED	1
⊙ 302GJ44110	2GJ44110	CLUTCH REG	1
⊙ 302H024370	2H024370	BUSH 6 EW	1
⊙ 302H702590	2H702590	BUSH SCREW	1
302HS02540	2HS02540	PIN DRAWER	1
302J002010	2J002010	FOOT	1
303J806010	3J806010	BRACKET FEED	1
303J806020	3J806020	COVER FEED	1
⊙ 303J806030	3J806030	ACTUATOR	1
303J806080	3J806080	HOLDER RELEASE	1
303J806090	3J806090	SHAFT MIDDLE C	1
⊙ 303J806100	3J806100	ROLLER MIDDLE ASSY	1
303J806120	3J806120	SPRING FEED	2
⊙ 303J806140	3J806140	BEARING 106	1
303J809040	3J809040	STOPPER SPRING FEED	2
⊙ 303LF01010	3LF01010	P.W.B BOARD ASSY PF CONT WITH SOFTWARE	1
⊙ 303LF02010	3LF02010	BASE	1
303LF02020	3LF02020	FRAME TOP	1
⊙ 303LF02030	3LF02030	COVER TOP	1
303LF02040	3LF02040	MOUNT DRAWER	1
303LF02111	3LF02111	SPRING EARTH PF	1
303LF06010	3LF06010	SHAFT FEED	1
303LF06020	3LF06020	PLATE EARTH FEED	1
⊙ 303LF09010	3LF09010	COVER CASSETTE	2
303LF09020	3LF09020	HOLDER CASSETTE	2
303LF09030	3LF09030	GUIDE CASSETTE	2
303LF31010	3LF31010	MOUNT MOTOR A	1
303LF31020	3LF31020	MOUNT MOTOR B	1

Part.No.	Alternative.	Description	Fig.No.
⊙ 303LF31030	3LF31030	GEAR Z64L-Z47S	1
⊙ 303LF31040	3LF31040	GEAR Z36S	1
⊙ 303LF31050	3LF31050	GEAR Z35S	1
⊙ 303LF31060	3LF31060	GEAR Z17S MIDDLE	1
⊙ 303LF31110	3LF31110	GEAR Z30S CLUTCH	1
⊙ 303LF46010	3LF46010	CONN.CORD ASSY S03310	1
303LF46020	3LF46020	CONN.CORD ASSY S03311	1
303LF46030	3LF46030	CONN.CORD ASSY S03312	1
303LF46040	3LF46040	CONN.CORD ASSY S03313	1
⊙ 303LF46050	3LF46050	CONN.CORD ASSY S03314	1
303LF46060	3LF46060	CONN.CORD ASSY S03390	1
⊙ 303LF93010	3LF93010	CT-131	2
⊙ 303LF94010	3LF94010	BRACKET FEED ASSY SP	1
5MMP141LD002	2A807510	PLATE SIDE GUIDE /A49 CASSETTE A4	2
5MMP141LD003	2A807520	PLATE STOPPER /A49 CASSETTE A4	2
5MMW171LD006	2A807530	SPRING STOPPER /A49 CASSETTE A4	2
5MMW251LD045	2A807140	SPRING LOCK /A-49 CASSETTE A4	2
5MMW341LD005	2A802070	SPRING PIN CASSETTE/A-49 FRAME A4	1
5MVG127DN071	2A807050	GEAR CASSETTE /A-49 CASSETTE A4	2
5MVT611DW001	3BW02040	PIN FEEDER /A-49 FEEDER A3	1
⊙ 5MVX111DN003	2A806250	RING STOPPER /A-49 FEED A4	1
5MVX431DW001	2A807121	LOCK CASSETTE R /A-49 CASSETTE A4	2
5MVX431DW002	2A807131	LOCK CASSETTE L /A-49 CASSETTE A4	2
⊙ 5MVX432DB011	3BW06010	ACTUATOR FEEDER PE /A-49 FEEDER A3	1
5MVX541DG002	2A807191	LEVER REAR /A-49 CASSETTE A3	2
5MVX541DG003	2A807161	LEVER SIDE /A-49 CASSETTE A3	2
⊙ 7NXSG2481+++H01	NX052600	SENSOR OPT.	1
7YZM210006++H01	YZ038000	ACCESS.EDGING	1
7YZM420003++H01	YZ052580	ACCESS.BAND	1
7YZM610009++H01	YZ042980	ACCESS.SADDLE	1

• Parts with "⊙" indicate regular maintenance parts.

KYOCERA MITA EUROPE B.V.

Hoeksteen 40, 2132 MS Hoofddorp,
The Netherlands
Phone: +31.20.654.0000
Home page: <http://www.kyoceramita-europe.com>
Email: info@kyoceramita-europe.com

KYOCERA MITA NEDERLAND B.V.
Beechavenue 25, 1119RA Schiphol-Rijk
The Netherlands
Phone: +31.20.58.77.200

KYOCERA MITA (UK) LTD
8 Beacontree Plaza
Gillette Way Reading Berks RG2 0BS,
U.K.
Phone: +44.1189.311.500

KYOCERA MITA ITALIA S.p.A.
Via G. Verdi, 89 / 91, 20063 Cernusco s/N
Milano, Italy
Phone: +39.02.92179.1

S.A. KYOCERA MITA BELGIUM N.V.
Hermestraat 8A, 1930 Zaventem,
Belgium
Phone: +32.2.720.9270

KYOCERA MITA FRANCE S.A.
Parc Les Algorithmes Saint Aubin
91194 GIF-SUR-YVETTE,
France
Phone: +33.1.6985.2600

KYOCERA MITA ESPAÑA S.A.
Edificio Kyocera, Avda de Manacor No. 2,
28290 Las Matas (Madrid),
Spain
Phone: +34.91.631.8392

KYOCERA MITA FINLAND OY
Kirvesmiehenkatu 4, 00880 Helsinki,
Finland
Phone: +358.9.4780.5200

KYOCERA MITA (SCHWEIZ)
Hohlstrasse 614, 8048 Zürich
Switzerland
Phone: +41.1.908.4949

KYOCERA MITA DEUTSCHLAND GMBH
Otto-Hahn-Str. 12 D-40670 Meerbusch,
Germany
Phone: +49.2159.918.0

KYOCERA MITA GMBH AUSTRIA
Eduard-Kittenberger-Gasse 95,
1230 Wien,
Austria
Phone: +43.1.86338.210

KYOCERA MITA SVENSKA AB
Esbogatan 16B 164 75 Kista,
Sweden
Phone: +46.8.546.55000

KYOCERA MITA NORGE
Postboks 150 Oppsal, NO 0619 Oslo
Olaf Helsetsvei 6, NO 0694 Oslo,
Norway
Phone: +47.22.62.73.00

KYOCERA MITA DANMARK A/S
Ejby Industrivej 1, DK-2600 Glostrup,
Denmark
Phone: +45.5687.1100

KYOCERA MITA PORTUGAL LDA.
Rua do Centro Cultural, 41 (Alvalade) 1700-106 Lisbon,
Portugal
Phone: +351.21.842.9100

KYOCERA MITA SOUTH AFRICA (PTY) LTD.
527 Kyalami Boulevard,
Kyalami Business Park Midrand,
South Africa
Phone: +27.(0)11.540.2600

KYOCERA MITA AMERICA, INC.

Headquarters:
225 Sand Road,
Fairfield, New Jersey 07004-0008,
U.S.A.
Phone: (973) 808-8444

KYOCERA MITA AUSTRALIA PTY. LTD.
Level 3, 6-10 Talavera Road, North Ryde,
N.S.W. 2113 Australia
Phone: (02) 9888-9999

KYOCERA MITA NEW ZEALAND LTD.
1-3 Parkhead Place, Albany
P.O. Box 302 125 NHPC, Auckland,
New Zealand
Phone: (09) 415-4517

KYOCERA MITA (THAILAND) CORP., LTD.
9/209 Ratchada-Prachachem Road,
Bang Sue, Bangkok 10800, Thailand
Phone: (02) 586-0320

KYOCERA MITA SINGAPORE PTE LTD.
121 Genting Lane, 3rd Level,
Singapore 349572
Phone: 67418733

KYOCERA MITA HONG KONG LIMITED
11/F., Mita Centre,
552-566, Castle Peak Road,
Tsuen Wan, New Territories,
Hong Kong
Phone: 24297422

KYOCERA MITA TAIWAN Corporation.
7F-1~2, No.41, Lane 221, Gangchi Rd.
Neihu District, Taipei, Taiwan, 114. R.O.C.
Phone: (02) 87511560

KYOCERA MITA Corporation

2-28, 1-chome, Tamatsukuri, Chuo-ku
Osaka 540-8585, Japan
Phone: (06) 6764-3555
<http://www.kyoceramita.com>

KYOCERA MITA AMERICA, INC.

Headquarters:

225 Sand Road,
Fairfield, New Jersey 07004-0008
TEL : (973) 808-8444
FAX : (973) 882-6000

New York Branch:

1410 Broadway 23rd floor
New York, NY 10018
TEL : (917) 286-5400
FAX : (917) 286-5402

Northeastern Region:

225 Sand Road,
Fairfield, New Jersey 07004-0008
TEL : (973) 808-8444
FAX : (973) 882-4401

Midwestern Region:

201 Hansen Court Suite 119
Wood Dale, Illinois 60191
TEL : (630) 238-9982
FAX : (630) 238-9487

Western Region:

14101 Alton Parkway,
Irvine, California 92618-7006
TEL : (949) 457-9000
FAX : (949) 457-9119

Southeastern Region:

1500 Oakbrook Drive,
Norcross, Georgia 30093
TEL : (770) 729-9786
FAX : (770) 729-9873

Southwestern Region:

2825 West Story Road,
Irving, Texas 75038-5299
TEL : (972) 550-8987
FAX : (972) 252-9786

National Operation Center & National Training Center:

2825 West Story Road,
Irving, Texas 75038-5299
TEL : (972) 659-0055
FAX : (972) 570-5816

Latin America Division:

8240 N.W. 52nd. Terrace Dawson Building,
Suite 108 Miami, Florida 33166
TEL : (305) 421-6640
FAX : (305) 421-6666

KYOCERA MITA CANADA, LTD.

6120 Kestrel Road, Mississauga,
Ontario L5T 1S8, Canada
TEL : (905) 670-4425
FAX : (905) 670-8116

KYOCERA MITA MEXICO, S.A. DE C.V.

Av. 16 de Septiembre #407
Col. Santa Inés,
Azcapotzalco México,
D.F. 02130, México
TEL : (55) 5383-2741
FAX : (55) 5383-7804

©2010 KYOCERA MITA Corporation

<http://www.kyoceramita.com>

 **KYOCERA** is a trademark of Kyocera Corporation

Printed in U.S.A.