

## 13M Series Megapixel Varifocal Lens

C785M-C (3/13)

### Important Safety Instructions

1. Read, follow, and keep all instructions.
2. Heed all warnings.
3. Thoroughly familiarize yourself with the information in this manual prior to installation and operation.
4. Servicing should be done only by qualified service personnel.
5. Only use replacement parts recommended by Pelco.

### Description

These lenses are varifocal lenses designed for 1/3-inch format cameras with 5 megapixels (MPx) or less in resolution. These lenses, which were designed for CS-mount cameras, produce high precision images from the image center to the image corner, fully exploiting the performance of megapixel cameras. Megapixel lenses are best suited for high-quality image surveillance with a megapixel camera as well as with a standard definition camera.

### MODELS

13M2.2-6	1/3-inch format, up to 5 MPx varifocal lens; 2.2 ~ 6.0 mm; f/1.3 ~ 2.0 auto iris; CS mount
13M2.8-8	1/3-inch format, up to 5 MPx varifocal lens; 2.8 ~ 8.0 mm; f/1.2 ~ 1.9 auto iris; CS mount
13M2.8-12	1/3-inch format, up to 5 MPx varifocal lens; 2.8 ~ 12.0 mm; f/1.4 ~ 2.7 auto iris; CS mount
13M15-50	1/3-inch format, up to 5 MPx varifocal lens; 15 ~ 50.0 mm; f/1.5 ~ 2.1 auto iris; CS mount

### Installation

1. Press the threaded portion of the lens mount against the threaded portion of the camera mount.
2. Slowly rotate the lens clockwise.
3. Screw in the lens mount.
4. Connect the auto iris lens cable to the electrical connector on the camera.

#### NOTES:

- The lens mount is equipped with a slip mechanism. To change the rotational position of the lens, rotate the lens until it reaches the stop (cannot be rotated further), and then rotate it counterclockwise to the required position.
- The iris control for this lens cannot be activated with a video signal. Use a camera that can send a DC signal.

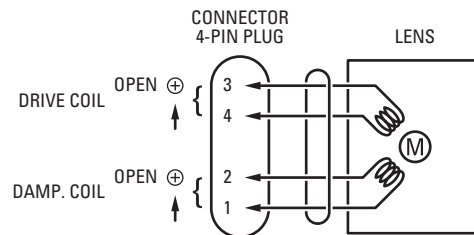

Figure 1. Lens and Connector Wiring

## Operation

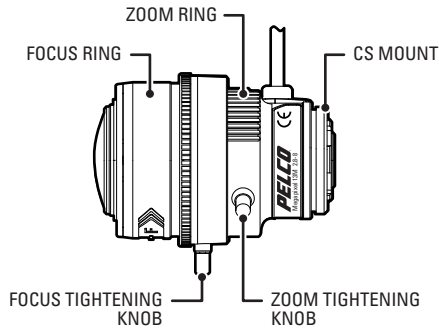

Figure 2. Adjustment Controls (13M2.8-8 Shown)

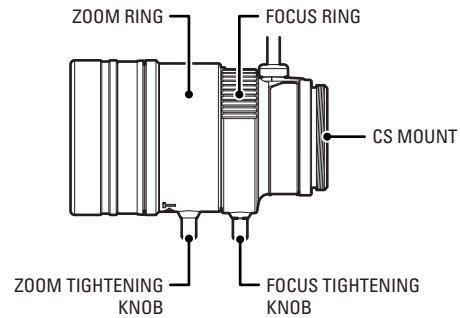

Figure 3. Adjustment Controls (13M15-50 Shown)

### ADJUSTING THE ZOOM

**NOTE:** The lens is a varifocal lens. After a zoom operation, you will need to set the focus.

1. Loosen the zoom tightening knob.
2. Rotate the zoom ring to select the appropriate angular field of view.
  - Rotate the ring to "W" to set the zoom to wide.
  - Rotate the ring to "T" to set the zoom to telephoto.
3. Adjust the focus; refer to *Setting the Focus*.
4. Tighten the zoom tightening knob.

### SETTING THE FOCUS

1. Loosen the focus tightening knob.
2. Rotate the focus ring to adjust the focus.
  - Rotate the ring to "F" to set the focus to infinity.
  - Rotate the ring to "N" to set the focus to near.
3. Tighten the focus tightening knob.

### SETTING THE AUTO BACK FOCUS

Megapixel lenses work with Pelco's Sarix® cameras. The auto back focus feature of Sarix cameras saves time because a single button sets the auto back focus mechanism.

To Set the auto back focus:

1. Press the button once to center the auto back focus mechanism and to fully open the iris.
2. Press and hold the button for three seconds to start the auto back focus mechanism.

**NOTE:** If you do not have a camera with auto back focus and you cannot get the lens to focus despite repeated attempts, refer to *Adjusting the Camera Flange Focal Length* and the appropriate camera manual for detailed instructions.

### ADJUSTING THE CAMERA FLANGE FOCAL LENGTH

1. Open the lens iris.
2. Set the zoom at the wide end and the focus at the near end for 13M2.2-6, 13M2.8-8, and 13M2.8-12. For the 13M15-50 lens, set the zoom at the telephoto end and the focus at the infinity end.
3. Operate the flange focal length adjustment mechanism on the camera, and then focus on an object at 11.8 inches (0.3 m) from the lens for the 13M2.2-6, 13M2.8-8 and 13M2.8-12 lenses. For the 13M15-50 lens, focus on an object that is more than 8.8 yards (8.0 m) from the lens.
4. Confirm the focus at the telephoto end, around the middle, and at the wide end throughout the zoom range.
5. If necessary, repeat this procedure until the focus is correct.

For additional assistance, contact Pelco Product Support at 1-800-289-9100 (USA and Canada) or +1-559-292-1981 (international).

## ROUTINE SERVICING

A special coating has been applied to the lens surface to prevent light reflection. A dirty lens surface due to dust, oil, or fingerprints causes harmful glare, which degrades the lens properties. Dirt can also cause mold or scratches on the lens.

**NOTE:** Be careful not to damage the lens while cleaning.

To remove dust, brush or dust off the lens with an oil-free soft brush or blower brush (for photography use).

To remove oil, fingerprints, or water drops:

1. Apply alcohol or lens cleaning liquid to a clean, soft, oil-free cotton cloth or lens cleaning paper. Using a spiral motion, moving from the center of the lens to the rim, gently wipe the lens.
2. With another clean soft cloth, gently wipe off the rest of the dirt, and then dry the lens surface.
3. Repeat this process as necessary until the lens is completely clean.

## Specifications

	<b>13M2.2-6</b>	<b>13M2.8-8</b>	<b>13M2.8-12</b>	<b>13M15-50</b>
Type	Varifocal	Varifocal	Varifocal	Varifocal
Format Size	1/3-inch	1/3-inch	1/3-inch	1/3-inch
Mount	CS mount	CS mount	CS mount	CS mount
Focal Length	2.2 – 6.0 mm	2.8 – 8.0 mm	2.8 – 12.0 mm	15.0 – 50.0 mm
Zoom Ratio	2.7X	2.8X	4.3X	3.3X
F-number (iris fully opened)	1.3 – 2.0	1.2 – 1.9	1.4 – 2.7	1.5 – 2.2
Image Size	6 mm diameter	6 mm diameter	6 mm diameter	6 mm diameter
Flange Focal Length	12.5 mm	12.5 mm	12.5 mm	12.5 mm
Minimum Object Distance	0.3 m	0.3 m	0.3 m	0.8 m
Iris	Auto	Auto	Auto	Auto
Field of View				
Wide				
Vertical	91°	73°	74°	14°
Horizontal	120°	100°	100°	18°
Diagonal	146°	128°	127°	23°
Tele				
Vertical	35°	26°	17°	4.2°
Horizontal	46°	35°	23°	5.6°
Diagonal	57°	43°	29°	6.9°
Focus	Manual	Manual	Manual	Manual
Zoom	Manual	Manual	Manual	Manual
Operating Temperature	–10° to 50°C (14° to 122°F)	–10° to 50°C (14° to 122°F)	–10° to 50°C (14° to 122°F)	–10° to 50°C (14° to 122°F)
Storage Temperature	–20° to 60°C (–4° to 140°F)	–20° to 60°C (–4° to 140°F)	–20° to 60°C (–4° to 140°F)	–20° to 60°C (–4° to 140°F)
Relative Humidity	35% to 90%	35% to 90%	35% to 90%	35% to 90%
Iris Drive Coil Resistance	190 Ω ±10%	190 Ω ±10%	190 Ω ±10%	190 Ω ±10%
Iris Damping Coil Resistance	500 Ω ±10%	500 Ω ±10%	500 Ω ±10%	500 Ω ±10%
Maximum Iris Operating Current	23 mA at 4 VDC	23 mA at 4 VDC	23 mA at 4 VDC	23 mA at 4 VDC
Height	4.71 cm (1.85 in.)	4.71 cm (1.85 in.)	5.11 cm (2.01 in.)	4.55 cm (1.79 in.)
Diameter	4.08 cm (1.61 in.)	4.08 cm (1.61 in.)	4.88 cm (1.92 in.)	3.75 cm (1.48 in.)
Length	5.40 cm (2.13 in.)	5.20 cm (2.05 in.)	6.55 cm (2.58 in.)	5.85 cm (2.30 in.)
Unit Weight (approximate)	0.06 kg (0.13 lb.)	0.06 kg (0.13 lb.)	0.09 kg (0.20 lb.)	0.06 kg (0.13 lb.)

**NOTE:** When power is turned off, the iris will close automatically.

202B11714141

 The materials used in the manufacture of this document and its components are compliant to the requirements of Directive 2002/95/EC.



This equipment contains electrical or electronic components that must be recycled properly to comply with Directive 2002/96/EC of the European Union regarding the disposal of waste electrical and electronic equipment (WEEE). Contact your local dealer for procedures for recycling this equipment.

## PRODUCT WARRANTY AND RETURN INFORMATION

### WARRANTY

Pelco will repair or replace, without charge, any merchandise proved defective in material or workmanship **for a period of one year** after the date of shipment.

Exceptions to this warranty are as noted below:

- Five years:
  - Fiber optic products
  - Unshielded Twisted Pair (UTP) transmission products
  - CC3701H-2, CC3701H-2X, CC3751H-2, CC3651H-2X, MC3651H-2, and MC3651H-2X camera models
- Three years:
  - FD Series and BU Series analog camera models
  - Fixed network cameras and network dome cameras with Sarix® technology
  - Sarix thermal imaging products (TI and ESTI Series)
  - Fixed analog camera models (C20 Series, CCC1390H Series, C10DN Series, and C10CH Series)
  - EH1500 Series enclosures
  - Spectra® IV products (including Spectra IV IP)
  - Spectra HD dome products
  - Camclosure® IS Series integrated camera systems
  - DX Series video recorders (except DX9000 Series which is covered for a period of one year), DVR5100 Series digital video recorders, Digital Sentry® Series hardware products, DVX Series digital video recorders, and NVR300 Series network video recorders
  - Endura® Series distributed network-based video products
  - Genex® Series products (multiplexers, server, and keyboard)
  - PMCL200/300/400 Series LCD monitors
  - PMCL5xxF Series and PMCL5xxNB Series LCD monitors
  - PMCL5xxxBL Series LED monitors
- Two years:
  - Standard varifocal, fixed focal, and motorized zoom lenses
  - DF5/DF8 Series fixed dome products
  - Legacy® Series integrated positioning systems
  - Spectra III™, Spectra Mini, Spectra Mini IP, Esprit®, ExSite®, ExSite IP, and PS20 scanners, including when used in continuous motion applications
  - Esprit Ti and TI2500 Series thermal imaging products
  - Esprit and WW5700 Series window wiper (excluding wiper blades)
  - CM6700/CM6800/CM9700 Series matrix
  - Digital Light Processing (DLP®) displays (except lamp and color wheel). The lamp and color wheel will be covered for a period of 90 days. The air filter is not covered under warranty.

- Six months:

- All pan and tilts, scanners, or preset lenses used in continuous motion applications (preset scan, tour, and auto scan modes)

Pelco will warrant all replacement parts and repairs for 90 days from the date of Pelco shipment. All goods requiring warranty repair shall be sent freight prepaid to a Pelco designated location. Repairs made necessary by reason of misuse, alteration, normal wear, or accident are not covered under this warranty.

Pelco assumes no risk and shall be subject to no liability for damages or loss resulting from the specific use or application made of the Products. Pelco's liability for any claim, whether based on breach of contract, negligence, infringement of any rights of any party or product liability, relating to the Products shall not exceed the price paid by the Dealer to Pelco for such Products. In no event will Pelco be liable for any special, incidental, or consequential damages (including loss of use, loss of profit, and claims of third parties) however caused, whether by the negligence of Pelco or otherwise.

The above warranty provides the Dealer with specific legal rights. The Dealer may also have additional rights, which are subject to variation from state to state.

If a warranty repair is required, the Dealer must contact Pelco at (800) 289-9100 or (559) 292-1981 to obtain a Repair Authorization number (RA), and provide the following information:

1. Model and serial number
2. Date of shipment, P.O. number, sales order number, or Pelco invoice number
3. Details of the defect or problem

If there is a dispute regarding the warranty of a product that does not fall under the warranty conditions stated above, please include a written explanation with the product when returned.

Method of return shipment shall be the same or equal to the method by which the item was received by Pelco.

### RETURNS

To expedite parts returned for repair or credit, please call Pelco at (800) 289-9100 or (559) 292-1981 to obtain an authorization number (CA number if returned for credit, and RA number if returned for repair) and designated return location.

All merchandise returned for credit may be subject to a 20 percent restocking and refurbishing charge.

Goods returned for repair or credit should be clearly identified with the assigned CA or RA number and freight should be prepaid.

Revised 10-9-12

### REVISION HISTORY

Manual #	Date	Comments
C785M	12/08	Original version.
C785M-A	1/09	Added figure 3. Revised information in <i>Flange Focal Adjustment</i> and F-number information in <i>Specifications</i>
C785M-B	7/10	Revised Figure 2, fields of view, dimensions, and weight change. Also changed warranty and applied new format.
C785M-C	3/13	Revised to show compatibility with up to 5MPx cameras, made imperial/metric changes.

 The materials used in the manufacture of this document and its components are compliant to the requirements of Directive 2002/95/EC.

Pelco, the Pelco logo, and other trademarks associated with Pelco products referred to in this publication are trademarks of Pelco, Inc. or its affiliates. ONVIF and the ONVIF logo are trademarks of ONVIF Inc. All other product names and services are the property of their respective companies. Product specifications and availability are subject to change without notice.

© Copyright 2013, Pelco, Inc.  
All rights reserved.