

Item Number
RAM-VBD-126

RAM Drill Seat Bases

RAM Mounting Systems

Vehicle base for the
FORD BRONCO (1996-OLDER)
FORD EXPEDITION (1996-OLDER)
FORD F-150 (1996-OLDER)
FORD F-250 (1996-OLDER)



Shown In Use

SPECIFICATIONS

Placement

Transmission Hump

Drilling Required

Yes

Seat Configuration

Bucket/Bench

Pole or Pedestal

Sold Separately

Construction/Finish

Steel/Black Powdercoat

Weight

2.9 lbs.

Dimensions

A = 3.75", B = 8.75", C = 9" D = 4

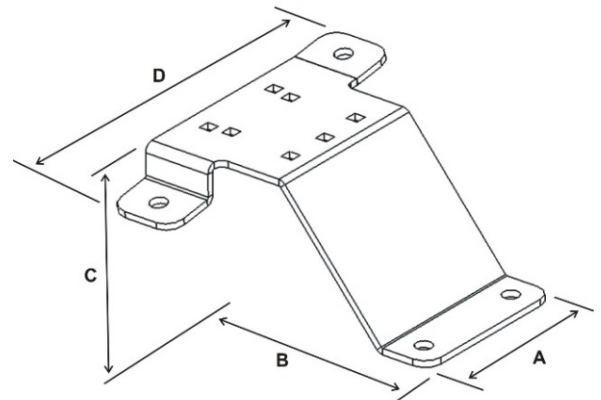

RAM-VBD-126

Features

Low footprint design

Misc.

Rugged Steel Construction
Lifetime warranty

RAM Mounting Systems

8410 Dallas Ave S
Seattle, WA 98108
Phone: (206) 763-8361
Fax: (206) 763-9615
www.rammount.com
support@rammount.com



RMR-INS-VBD-126

Item Number
RAM-VBD-126

RAM Drill Seat Bases

RAM Mounting Systems

Vehicle base for the
FORD BRONCO (1996-OLDER)
FORD EXPEDITION (1996-OLDER)
FORD F-150 (1996-OLDER)
FORD F-250 (1996-OLDER)

INSTALLATION INSTRUCTIONS

1. Determine the best location for the base on the transmission hump.
2. Locate base on hump with floor pan flange orientated on the passenger side of the vehicle. Make sure that the hump flanges are in contact with the top of the hump.
3. Mark mounting holes and check to see if any edges of the base need to be shimmed.
4. Drill 13/32" holes at each of the marked locations. Please be careful not to damage any equipment that might be underneath the floor boards.
5. Attach base with bolts, washers, and nuts. Do not use sheet metal screws. If floor is less than 1/4" thick, please use fender washers to help disperse the weight.

RAM Mounting Systems
8410 Dallas Ave S
Seattle, WA 98108
Phone: (206) 763-8361
Fax: (206) 763-9615
www.rammount.com
support@rammount.com



RMR-INS-VBD-126