

Item Number
RAM-VB-117

RAM No-Drill™ Seat Bases

RAM Mounting Systems

Vehicle base for the
CHEVROLET CAMARO CAR (1993-2002)
CHEVROLET CAPRICE CAR (1990-1995)
FORD CROWN VICTORIA POLICE INTERCEPTOR CAR (1991-2011)
LINCOLN TOWN CAR (2005-2010)

SPECIFICATIONS

Placement

Passenger side on the floor, in front of seat

Drilling Required

No - uses existing seat bolts

Pole or Pedestal

Included with base

Seat Configuration

Bucket/Bench

Weight

10.7 lbs.

Construction/Finish

Steel/Black Powdercoat

Dimensions

A = 17.57", B = 5.5", C = 11"

Hole Center = 6.38"

Features

Installs in minutes with no drilling required

Misc.

Rugged steel construction
Lifetime warranty



Shown In Use

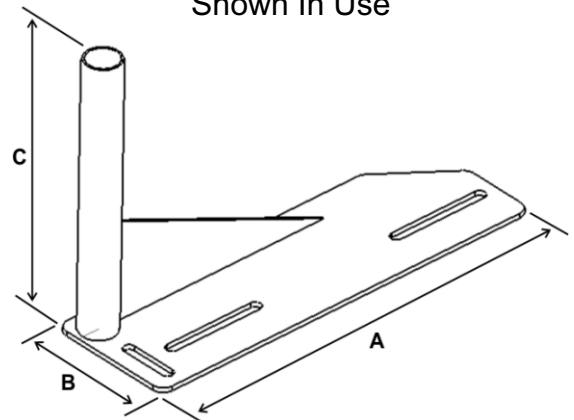

RAM-VB-117

RAM Mounting Systems
8410 Dallas Ave S
Seattle, WA 98108
Phone: (206) 763-8361
Fax: (206) 763-9615
www.rammount.com
support@rammount.com



RMR-INS-VB-117

Item Number
RAM-VB-117

RAM No-Drill™ Seat Bases

RAM Mounting Systems

Vehicle base for the

CHEVROLET CAMARO CAR (1993-2002)

CHEVROLET CAPRICE CAR (1990-1995)

FORD CROWN VICTORIA POLICE INTERCEPTOR CAR (1991-2011)

LINCOLN TOWN CAR (2005-2010)

INSTALLATION INSTRUCTIONS

1. Move the passenger seat to the rearmost setting.
2. Remove the front seat rail bolts that fasten the passenger seat brackets to the vehicle floor.
3. Gently lift the front of the seat upward to allow the seat frame to clear the bolts.
4. Place the base between the seat frame and align the holes in the base with the seat bolts.
5. Lower the seat back down over the No-Drill™ base and seat bolts.
6. Fully tighten factory hardware to secure base in place along with seat frame.

RAM Mounting Systems
8410 Dallas Ave S
Seattle, WA 98108
Phone: (206) 763-8361
Fax: (206) 763-9615
www.rammount.com
support@rammount.com



RMR-INS-VB-117