

Item Number _____

RAM-VB-113 & RAM-VB-113-SW1

RAM No-Drill™ Seat Bases

RAM Mounting Systems

Vehicle base for the
FORD RANGER (1994-2011)
FORD EXPLORER SPORT TRAC (2001-2006)

SPECIFICATIONS

Placement

Passenger side floor board, over the top of the seat frame legs.

Drilling Required

No - uses existing seat bolts

Seat Configuration

Bucket/Bench

Construction/Finish

Steel/Black Powdercoat

Pole or Pedestal

Purchased Separately

Weight

7 lbs.

Dimensions

A = 11.75", B = 7.75", C = 2.5", D = 6.38"

E = 16.25, Hole Center 9.25"

Tools required for base installation

15mm socket for base installation and 1/2" box end wrench for riser attachment . Tools for complete system assembly: pliers, phillips screw driver, #10, 1/2", 9/16" box end wrench's.

Notes.

One 4" riser is included with this vehicle base. Riser allows optimized placement of mount with a minimal amount of intrusion of passenger leg space. Will not interfere with levers or factory installed consoles.



RAM-VB-113-SW1

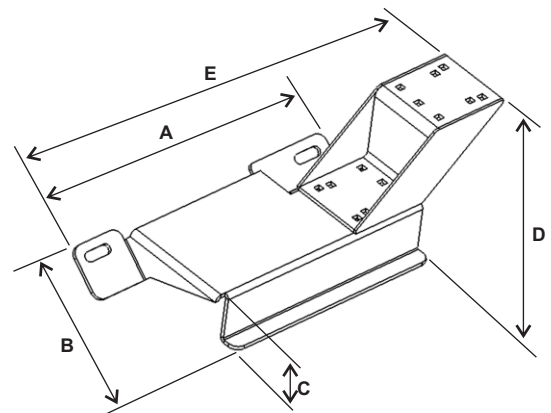

RAM-VB-113, SHOWN WITH RAM-VB-SB4 RISER (INCLUDED)

RAM Mounting Systems

8410 Dallas Ave S
Seattle, WA 98108
Phone: (206) 763-8361
Fax: (206) 763-9615
www.rammount.com
support@rammount.com



RMR-INS-VB-113

Item Number _____

RAM-VB-113 & RAM-VB-113-SW1

RAM No-Drill™ Seat Bases
RAM Mounting Systems**Vehicle base for the**
FORD RANGER (1994-2011)
FORD EXPLORER SPORT TRAC (2001-2006)**INSTALLATION INSTRUCTIONS**

Tools required for installation of base into vehicle are a 15mm socket and a 3/8" drive socket wrench. Tools required to attach the angled riser to the No-Drill™ base are a 1/2" box end wrench.

1. Move the passenger seat back to its rear-most position.
2. Using the 15mm socket and wrench, loosen and remove the two hex bolts holding the passenger side seat frame legs to the vehicle floor. Set these aside.
3. If you are using the angled riser, attach this to the No-Drill™ base now. Place the carriage bolts through from the top so the washers and nuts are on the underside of the base. Order is carriage bolt, flat washer, lock washer, nut.
4. Without moving the seat, place the No-Drill™ base over the front of the seat frame legs. Align the slots in the base with the holes in the seat frame legs and floor board.
5. Using the factory seat leg bolts previously removed, pass each through the No-Drill™ base, through the seat frame legs, and start the thread by hand into the vehicle floor board.
6. Using the 15mm socket and wrench, fully tighten the seat leg bolts securing the No-Drill™ base and passenger seat to the vehicle floor. Torque to 39 ft lbs. Be sure not to pinch the floor mat beneath the No-Drill™ base as this may cause the installation to be uneven.

RAM Mounting Systems
8410 Dallas Ave S
Seattle, WA 98108
Phone: (206) 763-8361
Fax: (206) 763-9615
www.rammount.com
support@rammount.com



RMR-INS-VB-113