

Item Number _____

RAM-VB-141 & RAM-VB-141-SW1

RAM No-Drill™ Seat Bases

National Products, Inc.

**Vehicle base for the
JEEP LIBERTY (2002-2012)
DODGE NITRO (2007-2011)**

SPECIFICATIONS

Placement

Passenger side, front, where seat rail frame attaches to floor board.

Drilling Required

No - uses existing seat bolts

Seat Configuration

Bucket

Construction/Finish

Steel/Black Powdercoat

Dimensions

A = 12.75", B = 8", C = 5.25"

Hole Centers = 11"

Pole or Pedestal

Sold Separately

Weight

4.9 lbs.

Features

Installs in minutes with no drilling required
Low profile keeps mount away from passenger leg space

Misc.

Rock solid construction
Lifetime warranty

National Products, Inc.
8410 Dallas Ave S
Seattle, WA 98108

Phone: (206) 763-8361
Fax: (206) 763-9615
Website: www.ram-mount.com
Email: staff@ram-mount.com



RAM-VB-141-SW1

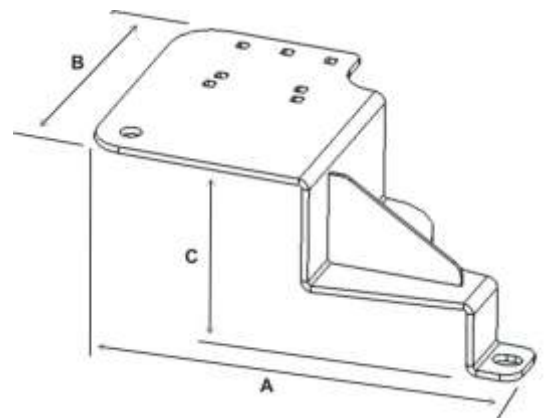

RAM-VB-141



Item Number _____

RAM-VB-141 & RAM-VB-141-SW1

RAM No-Drill™ Seat Bases

National Products, Inc.

Vehicle base for the
JEEP LIBERTY (2002-2012)
DODGE NITRO (2007-2011)

INSTALLATION INSTRUCTIONS

1. Move the passenger seat back to its rearmost position and remove the front seat rail bolts on the passenger side.
2. Without moving the seat, place the No-Drill™ base over the front of the seat frame legs.
3. Align the holes in the base with those of the seat frame legs. The pedestal platform should be near the console.
4. Re-install the seat bolts and fully tighten.

National Products, Inc.
8410 Dallas Ave S
Seattle, WA 98108

Phone: (206) 763-8361
Fax: (206) 763-9615
Website: www.ram-mount.com
Email: staff@ram-mount.com

