

**Item Number** \_\_\_\_\_

RAM-VB-107 & RAM-VB-107-SW1

# RAM No-Drill™ Seat Bases

RAM Mounting Systems

**Vehicle base for the  
CHEVROLET CAPRICE (1990-1995)  
FORD CROWN VICTORIA/POLICE INTERCEPTOR (1991-2011)**

## SPECIFICATIONS

**Placement**

Across transmission hump

**Drilling Required**

No - uses existing seat bolts

**Seat Configuration**

Bucket/60-40 split

**Construction/Finish**

Steel/Black Powdercoat

**Pole or Pedestal**

Ordered Separately

**Weight**

7.3 lbs.

**Dimensions**

A = 8.75", B = 5", C = 5.75", D = 9.25"

**Notes**

Central mounting location moves pole away from passenger leg space. There base is formed from one piece of steel. Drilling may be required on vehicles with 60-40 split seats.



Complete Vehicle Mount  
RAM-VB-107-SW1

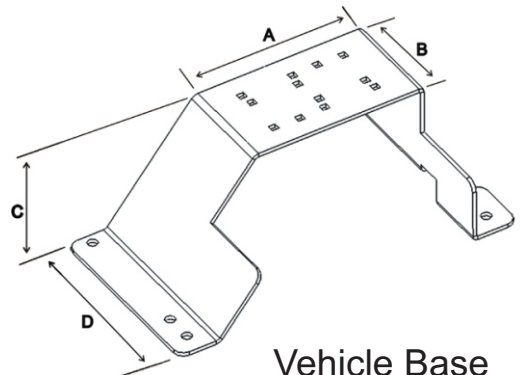

Vehicle Base  
RAM-VB-107

**RAM Mounting Systems**

8410 Dallas Ave S  
Seattle, WA 98108  
Phone: (206) 763-8361  
Fax: (206) 763-9615  
www.rammount.com  
support@rammount.com



RMR-INS-VB-107

**Item Number** \_\_\_\_\_

RAM-VB-107 & RAM-VB-107-SW1

**RAM No-Drill™ Seat Bases**  
RAM Mounting Systems

**Vehicle base for the**  
**CHEVROLET CAPRICE (1990-1995)**  
**FORD CROWN VICTORIA/POLICE INTERCEPTOR (1991-2011)**

**INSTALLATION INSTRUCTIONS**

1. Place both front seats in their most rear position.
2. Remove the drivers side front right and the passenger side front left seat mounting bolts (inner seat bolts).
3. Slightly lift both the passenger and driver seats and slide the No-Drill™ base between the floor of the vehicle and the bottom of the seat.
4. Align the holes and reinstall all of the seat bolts that have been removed.

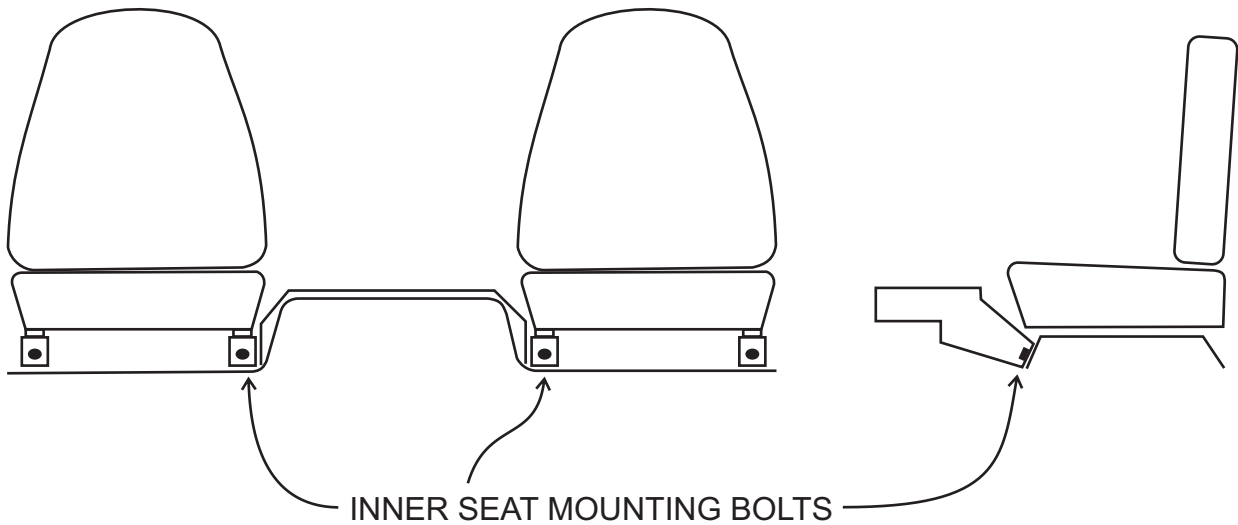

**RAM Mounting Systems**  
8410 Dallas Ave S  
Seattle, WA 98108  
Phone: (206) 763-8361  
Fax: (206) 763-9615  
www.rammount.com  
support@rammount.com



RMR-INS-VB-107