



TASKalfa 300i

SERVICE MANUAL

Published in February 2010
842K5111
2K5SM061
Rev. 1

CAUTION

RISK OF EXPLOSION IF BATTERY IS REPLACED BY AN INCORRECT TYPE. DISPOSE OF USED BATTERIES ACCORDING TO THE INSTRUCTIONS.

It may be illegal to dispose of this battery into the municipal waste stream. Check with your local solid waste officials for details in your area for proper disposal.

ATTENTION

IL Y A UN RISQUE D'EXPLOSION SI LA BATTERIE EST REMPLACÉE PAR UN MODÈLE DE TYPE INCORRECT. METTRE AU REBUT LES BATTERIES UTILISÉES SELON LES INSTRUCTIONS DONNÉES.

Il peut être illégal de jeter les batteries dans des eaux d'égout municipales. Vérifiez avec les fonctionnaires municipaux de votre région pour les détails concernant des déchets solides et une mise au rebut appropriée.

Revision history

Revision	Date	Replaced pages	Remarks
1	February 4, 2010	CONTENTS, 1-2-12, 1-3-4, 1-3-53, 1-3-63, 1-3-74, 1-3-82, 1-3-83, 1-4-6 to 1-4-8, 1-4-14, 1-5-32, 1-6-1, 2-4-3 to 2-4-6	-

This page is intentionally left blank.

Safety precautions

This booklet provides safety warnings and precautions for our service personnel to ensure the safety of their customers, their machines as well as themselves during maintenance activities. Service personnel are advised to read this booklet carefully to familiarize themselves with the warnings and precautions described here before engaging in maintenance activities.

Safety warnings and precautions

Various symbols are used to protect our service personnel and customers from physical danger and to prevent damage to their property. These symbols are described below:

 **DANGER:** High risk of serious bodily injury or death may result from insufficient attention to or incorrect compliance with warning messages using this symbol.

 **WARNING:** Serious bodily injury or death may result from insufficient attention to or incorrect compliance with warning messages using this symbol.

 **CAUTION:** Bodily injury or damage to property may result from insufficient attention to or incorrect compliance with warning messages using this symbol.

Symbols

The triangle () symbol indicates a warning including danger and caution. The specific point of attention is shown inside the symbol.

 General warning.

 Warning of risk of electric shock.

 Warning of high temperature.

 indicates a prohibited action. The specific prohibition is shown inside the symbol.

 General prohibited action.

 Disassembly prohibited.

 indicates that action is required. The specific action required is shown inside the symbol.



 General action required.

 Remove the power plug from the wall outlet.



 Always ground the copier.

1. Installation Precautions

WARNING



- Do not use a power supply with a voltage other than that specified. Avoid multiple connections to one outlet: they may cause fire or electric shock. When using an extension cable, always check that it is adequate for the rated current. 
- Connect the ground wire to a suitable grounding point. Not grounding the copier may cause fire or electric shock. Connecting the earth wire to an object not approved for the purpose may cause explosion or electric shock. Never connect the ground cable to any of the following: gas pipes, lightning rods, ground cables for telephone lines and water pipes or faucets not approved by the proper authorities. 

CAUTION:

- Do not place the copier on an infirm or angled surface: the copier may tip over, causing injury. 
- Do not install the copier in a humid or dusty place. This may cause fire or electric shock. 
- Do not install the copier near a radiator, heater, other heat source or near flammable material.

This may cause fire. 

- Allow sufficient space around the copier to allow the ventilation grills to keep the machine as cool as possible. Insufficient ventilation may cause heat buildup and poor copying performance. 















- Always handle the machine by the correct locations when moving it. 
- Always use anti-toppling and locking devices on copiers so equipped. Failure to do this may cause the copier to move unexpectedly or topple, leading to injury. 

- Avoid inhaling toner or developer excessively. Protect the eyes. If toner or developer is accidentally ingested, drink a lot of water to dilute it in the stomach and obtain medical attention immediately. If it gets into the eyes, rinse immediately with copious amounts of water and obtain medical attention. 

- Advise customers that they must always follow the safety warnings and precautions in the copier's instruction handbook. 

2.Precautions for Maintenance

WARNING

- Always remove the power plug from the wall outlet before starting machine disassembly. 
 - Always follow the procedures for maintenance described in the service manual and other related brochures. 
 - Under no circumstances attempt to bypass or disable safety features including safety mechanisms and protective circuits. 
 - Always use parts having the correct specifications. 
 - Always use the thermostat or thermal fuse specified in the service manual or other related brochure when replacing them. Using a piece of wire, for example, could lead to fire or other serious accident. 
 - When the service manual or other serious brochure specifies a distance or gap for installation of a part, always use the correct scale and measure carefully. 
 - Always check that the copier is correctly connected to an outlet with a ground connection. 
 - Check that the power cable covering is free of damage. Check that the power plug is dust-free. If it is dirty, clean it to remove the risk of fire or electric shock. 
 - Never attempt to disassemble the optical unit in machines using lasers. Leaking laser light may damage eyesight. 
 - Handle the charger sections with care. They are charged to high potentials and may cause electric shock if handled improperly. 
- ### CAUTION
- Wear safe clothing. If wearing loose clothing or accessories such as ties, make sure they are safely secured so they will not be caught in rotating sections. 
 - Use utmost caution when working on a powered machine. Keep away from chains and belts. 
 - Handle the fixing section with care to avoid burns as it can be extremely hot. 
 - Check that the fixing unit thermistor, heat and press rollers are clean. Dirt on them can cause abnormally high temperatures. 

• Do not remove the ozone filter, if any, from the copier except for routine replacement.



• Do not pull on the AC power cord or connector wires on high-voltage components when removing them; always hold the plug itself.



• Do not route the power cable where it may be stood on or trapped. If necessary, protect it with a cable cover or other appropriate item.



• Treat the ends of the wire carefully when installing a new charger wire to avoid electric leaks.



• Remove toner completely from electronic components.



• Run wire harnesses carefully so that wires will not be trapped or damaged.



• After maintenance, always check that all the parts, screws, connectors and wires that were removed, have been refitted correctly. Special attention should be paid to any forgotten connector, trapped wire and missing screws.



• Check that all the caution labels that should be present on the machine according to the instruction handbook are clean and not peeling. Replace with new ones if necessary.



• Handle greases and solvents with care by following the instructions below:



· Use only a small amount of solvent at a time, being careful not to spill. Wipe spills off completely.

· Ventilate the room well while using grease or solvents.

· Allow applied solvents to evaporate completely before refitting the covers or turning the power switch on.

· Always wash hands afterwards.

• Never dispose of toner or toner bottles in fire. Toner may cause sparks when exposed directly to fire in a furnace, etc.



• Should smoke be seen coming from the copier, remove the power plug from the wall outlet immediately.



3. Miscellaneous

WARNING

• Never attempt to heat the drum or expose it to any organic solvents such as alcohol, other than the specified refiner; it may generate toxic gas.



This page is intentionally left blank.

CONTENTS

1-1 Specifications

1-1-1 Specifications	1-1-1
1-1-2 Parts names	1-1-3
(1) Machine	1-1-3
(2) Operation panel	1-1-6
1-1-3 Machine cross section	1-1-7

1-2 Installation

1-2-1 Installation environment	1-2-1
1-2-2 Unpacking and installation	1-2-2
(1) Installation procedure	1-2-2
(2) Setting initial copy modes	1-2-11
1-2-3 Installing the key counter (option)	1-2-12

1-3 Maintenance Mode

1-3-1 Maintenance mode	1-3-1
(1) Executing a maintenance item	1-3-1
(2) Maintenance modes item list	1-3-2
(3) Contents of the maintenance mode items	1-3-6
1-3-2 Management mode	1-3-95
(1) Using the management mode	1-3-95
(2) Common Settings	1-3-96
(3) Copy Settings	1-3-99
(4) Sending Settings	1-3-99
(5) Document Box Settings	1-3-99
(6) Printer Settings	1-3-100
(7) Printing Reports/Sending Notice	1-3-100
(8) Adjustment/Maintenance	1-3-101
(9) Date/Timer	1-3-101
(10) Editing Destination (Address Book/Adding One Touch Keys)	1-3-102
(11) Internet Browser Setup	1-3-103
(12) Applications	1-3-104
(13) System Settings	1-3-104
(14) User Login Administration	1-3-106
(15) Job accounting	1-3-107

1-4 Troubleshooting

1-4-1 Paper misfeed detection	1-4-1
(1) Paper misfeed indication	1-4-1
(2) Paper misfeed detection conditions	1-4-2
(3) Paper misfeeds	1-4-9
1-4-2 Self-diagnosis	1-4-18
(1) Self-diagnostic function	1-4-18
(2) Self diagnostic codes	1-4-20
1-4-3 Image formation problems	1-4-34
(1) No image appears (entirely white)	1-4-35
(2) No image appears (entirely black)	1-4-35
(3) Image is too light	1-4-36
(4) Background is visible	1-4-36
(5) A white line appears longitudinally	1-4-36
(6) A black line appears longitudinally	1-4-37
(7) A black line appears laterally	1-4-37
(8) One side of the copy image is darker than the other	1-4-37
(9) Black dots appear on the image	1-4-37
(10) Image is blurred	1-4-38
(11) The leading edge of the image is consistently misaligned with the original	1-4-38
(12) The leading edge of the image is sporadically misaligned with the original	1-4-38
(13) Paper creases	1-4-38
(14) Offset occurs	1-4-39
(15) Image is partly missing	1-4-39

(16) Fusing is poor.....	1-4-39
(17) Image is out of focus.....	1-4-39
(18) Image center does not align with the original center.....	1-4-40
1-4-4 Electric problems.....	1-4-41
1-4-5 Mechanical problems.....	1-4-46
1-4-6 Send error code.....	1-4-48
(1) Scan to SMB error codes.....	1-4-48
(2) Scan to FTP error codes.....	1-4-49
(3) Scan to E-mail error codes.....	1-4-50
(4) Network Twain error codes.....	1-4-51
(5) Software trouble error codes.....	1-4-51
1-5 Assembly and Disassembly	
1-5-1 Precautions for assembly and disassembly.....	1-5-1
(1) Precautions.....	1-5-1
(2) Drum.....	1-5-1
(3) Toner.....	1-5-1
(4) How to tell a genuine Kyocera Mita toner container.....	1-5-2
1-5-2 Paper feed section.....	1-5-3
(1) Detaching and refitting the forwarding, paper feed and separation pulleys.....	1-5-3
(2) Detaching and refitting the MP separation, MP paper feed and MP forwarding pulleys.....	1-5-6
1-5-3 Optical section.....	1-5-15
(1) Detaching and refitting the exposure lamp.....	1-5-15
(2) Detaching and refitting the scanner wires.....	1-5-19
(2-1) Detaching the scanner wires.....	1-5-19
(2-2) Fitting the scanner wires.....	1-5-21
(3) Detaching and refitting the ISU (reference).....	1-5-24
(4) Detaching and refitting the laser scanner unit.....	1-5-26
(5) Adjusting the position of the ISU (reference).....	1-5-30
1-5-4 Drum section.....	1-5-31
(1) Detaching and refitting the drum unit.....	1-5-31
(2) Detaching and refitting the main charger unit.....	1-5-33
(3) Detaching and refitting the drum separation claws.....	1-5-34
1-5-5 Developing section.....	1-5-35
(1) Detaching and refitting the developing unit.....	1-5-35
1-5-6 Transfer section.....	1-5-36
(1) Detaching and refitting the transfer roller unit.....	1-5-36
1-5-7 Fuser section.....	1-5-37
(1) Detaching and refitting the fuser unit.....	1-5-37
(2) Detaching and refitting the heat roller separation claws.....	1-5-40
(3) Detaching and refitting the press roller.....	1-5-41
(4) Detaching and refitting the fuser heater.....	1-5-43
(5) Detaching and refitting the heat roller.....	1-5-45
(6) Detaching and refitting the fuser thermistor 1.....	1-5-46
(7) Detaching and refitting the fuser thermistor 2.....	1-5-47
(8) Detaching and refitting the fuser thermostats 1 and 2.....	1-5-48
(9) Adjusting front position of the fuser unit (adjusting lateral squareness).....	1-5-50
1-5-8 Others.....	1-5-51
(1) Detaching and refitting the ozone filter 1.....	1-5-51
(2) Detaching and refitting the ozone filter 2.....	1-5-52
(3) Detaching and refitting the hard disk.....	1-5-53
(4) Direction of installing the principal fan motors.....	1-5-55
1-6 Requirements on PWB Replacement	
1-6-1 Upgrading the firmware.....	1-6-1
1-6-2 Adjustment-free variable resistors (VR).....	1-6-2
1-6-3 Remarks on main and engine PWB replacement.....	1-6-2
2-1 Mechanical construction	
2-1-1 Paper feed section.....	2-1-1
(1) Cassette paper feed section.....	2-1-1
(2) MP tray paper feed section.....	2-1-3
2-1-2 Main charging section.....	2-1-4

2-1-3	Optical section	2-1-5
	(1) Image scanner section	2-1-5
	(2) Laser scanner section	2-1-7
2-1-4	Developing section.....	2-1-9
	(1) Single component developing system.....	2-1-11
2-1-5	Transfer and separation sections.....	2-1-12
2-1-6	Cleaning and charge erasing sections.....	2-1-13
2-1-7	Fuser section	2-1-14
2-1-8	Eject and switchback sections	2-1-16
2-1-9	Duplex section	2-1-17
	(1) Paper conveying operation in duplex copying.....	2-1-19
2-2 Electrical Parts Layout		
2-2-1	Electrical parts layout.....	2-2-1
	(1) PWBs	2-2-1
	(2) Switches and sensors	2-2-3
	(3) Motors	2-2-5
	(4) Clutches and solenoids	2-2-7
	(5) Other electrical components.....	2-2-8
2-3 Operation of the PWBs		
2-3-1	Power source PWB.....	2-3-1
2-3-2	Engine PWB.....	2-3-4
2-3-3	Main PWB	2-3-13
2-3-4	Scanner PWB	2-3-21
2-3-5	Main operation PWB	2-3-24
2-4 Appendixes		
	Maintenance parts list	2-4-1
	Maintenance kits	2-4-2
	Periodic maintenance procedures	2-4-3
	Chart of image adjustment procedures.....	2-4-7
	Wiring diagram No.1	2-4-9
	Wiring diagram No.2	2-4-10
	Wiring diagram No.3	2-4-11
	Wiring diagram No.4	2-4-12
	Wiring diagram No.5	2-4-13
	Wiring diagram No.6	2-4-14
INSTALLATION GUIDE		
	DOCUMENT PROCESSOR	
	PAPER FEEDER	
	DOCUMENT FINISHER	
	BUILT-IN FINISHER	
	JOB SEPARATOR	
	FAX System	

This page is intentionally left blank.

1-1-1 Specifications

Machine

Type	Desktop
Printing method.....	Electrophotography by semiconductor laser
Supported original types	Sheets, books and three-dimensional objects Maximum original size: A3/Ledger
Original feed system	Fixed
Paper weight.....	Cassette : 60 to 120 g/m ² MP tray : 45 to 200 g/m ²
Paper type	Cassette: Plain, Rough, Vellum, Recycled, Preprinted, Bond, Color (Colour), Prepunched, Letterhead, Thick, High Quality, Custom 1 to 8 (Duplex: Same as Simplex) MP tray: Plain, Transparency (OHP film), Rough, Vellum, Labels, Recycled, Preprinted, Bond, Cardstock (Hagaki), Color (Colour), Prepunched, Letterhead, Thick, Envelope, High Quality, Custom 1 to 8
Paper size	Cassette: A3, B4, A4, A4R, B5, B5R, A5R, Ledger, Legal, Letter, LetterR, Statement, Oficio II, 8.5 x 13.5", Folio, 8K, 16K, 16KR MP tray: A3, B4, A4, A4R, B5, B5R, A5R, B6R, A6R, Ledger, Legal, Letter, LetterR, ExecutiveR, Statement, Oficio II, 8.5 x 13.5", Folio, 8K, 16K, 16KR, Postcards (100 x 148 mm), Return postcard (148 x 200 mm), Envelope DL, Envelope C5, Envelope C4, Envelope #10 (Commercial #10), Envelope #9 (Commercial #9), Envelope #6 (Commercial #6 3/4), Monarch, ISO B5, Youkei 2, Youkei 4
Zoom level	Manual mode: 25 to 400%, 1% increments Auto mode: Preset zoom
Printing speed.....	A4/Letter: 30 sheets/min. A4R/LetterR: 22 sheets/min. A3/Ledger: 15 sheets/min. B4/Legal: 15 sheets/min. B5: 30 sheets/min. B5R: 20 sheets/min. A5R: 14 sheets/min.
First copy time	5.1 s or less
Warm-up time	Room temperature 22°C/71.6°F, 60% RH Power on: 29 s or less Low power mode: 10 s or less Sleep mode: 15 s or less
Paper capacity	Cassette : 500 sheets (80 g/m ²) MP tray : 200 sheets (80 g/m ²)
Output tray capacity.....	Top tray : 250 sheets (80 g/m ²) When built-in finisher installed: 100 sheets (80 g/m ²) When job separator installed: 150 sheets (80 g/m ²)
Continuous copying	1 to 999 sheets
Light source	Inert gas lamp
Scanning system	Flat bed scanning by CCD image sensor
Photoconductor.....	a-Si (drum diameter 30 mm)
Image write system.....	Semiconductor laser and electrophotography
Charging system.....	Single positive corona charging
Developing system	Dry, reverse developing (single component system) Developer: 1-component, magnetism toner Toner replenishing: automatic from a toner container
Transfer system	Transfer roller
Separation system	Curvature separation and separation electrode
Cleaning system	Cleaning blade and roller
Charge erasing system.....	Exposure by cleaning lamp
Fusing system.....	Heat roller Heat source: halogen heaters Abnormally high temperature protection devices: thermostats
Main memory	Standard : 2048 MB Maximum: 2048 MB
Hard disk.....	160 GB

Interface.....	USB interface connector: 1 (USB Hi-speed) USB memory slot: 2 (Full-speed USB) Network interface: 1 (10 BASE-T/100 BASE-TX) Optional interface: 2 (KUIO/W)
Resolution.....	600 x 600 dpi
Operating environment	Temperature: 10 to 32.5°C/50 to 90.5°F Humidity: 15 to 80% RH Altitude: 2500 m/8,202 ft maximum Brightness: 1500 lux maximum
Dimensions	570 (W) x 630 (D) x 767 (H) mm (main unit only) 22 7/16" (W) x 24 13/16" (D) x 30 3/16" (H) (main unit only)
Weight.....	75 kg/165 lbs
Space required.....	725 (W) x 630 (D) mm (using MP tray) 28 9/16" (W) x 24 13/16" (D) (using MP tray)
Power source.....	120 V AC, 60 Hz, 11.8 A 220 to 240 V AC, 50/60 Hz, 6.5 A
Options	Document processor, paper feeder, document finisher, built-in finisher, job separator, key counter, fax kit, expansion memory, internet fax kit, data security kit and printed document guard kit

Printer functions

Printing speed.....	Same as copying speed
First print time	5.8 s or less
Resolution.....	600 dpi
Operating system.....	Windows 2000 (Service Pack 2 or later), Windows XP, Windows Server 2003, Windows Vista, Apple Macintosh OS 10.x
Interface.....	USB interface connector: 1 (USB Hi-speed) Network interface: 1 (10 BASE-T/100 BASE-TX)
Page description language	PRESCRIBE

Scanner functions

Operating system.....	Windows 2000 (Service Pack 2 or later), Windows XP, Windows Vista		
System requirements.....	CPU 600 MHz or higher RAM 128 MB or more		
Resolution.....	600 dpi, 400 dpi, 300 dpi, 200 dpi, 200 x 100 dpi, 200 x 400 dpi		
File format.....	TIFF (MMR/JPEG compression), JPEG, XPS, PDF (MMR/JPEG compression), PDF (high compression)		
Scanning speed	A4, 300 dpi, Image quality: Text/Photo original Single-sided: B/W: 50 images/min, Color: 15 images/min		
Interface.....	Ethernet (10 BASE-T/100 BASE-TX)		
Network protocol.....	TCP/IP		
Transmission system	PC transmission	SMB	Scan to SMB
		FTP	Scan to FTP, FTP over SSL
	E-mail transmission	SMTP	Scan to E-mail
	Twain scan		
	WIA scan		

NOTE: These specifications are subject to change without notice.

1-1-2 Parts names

(1) Machine

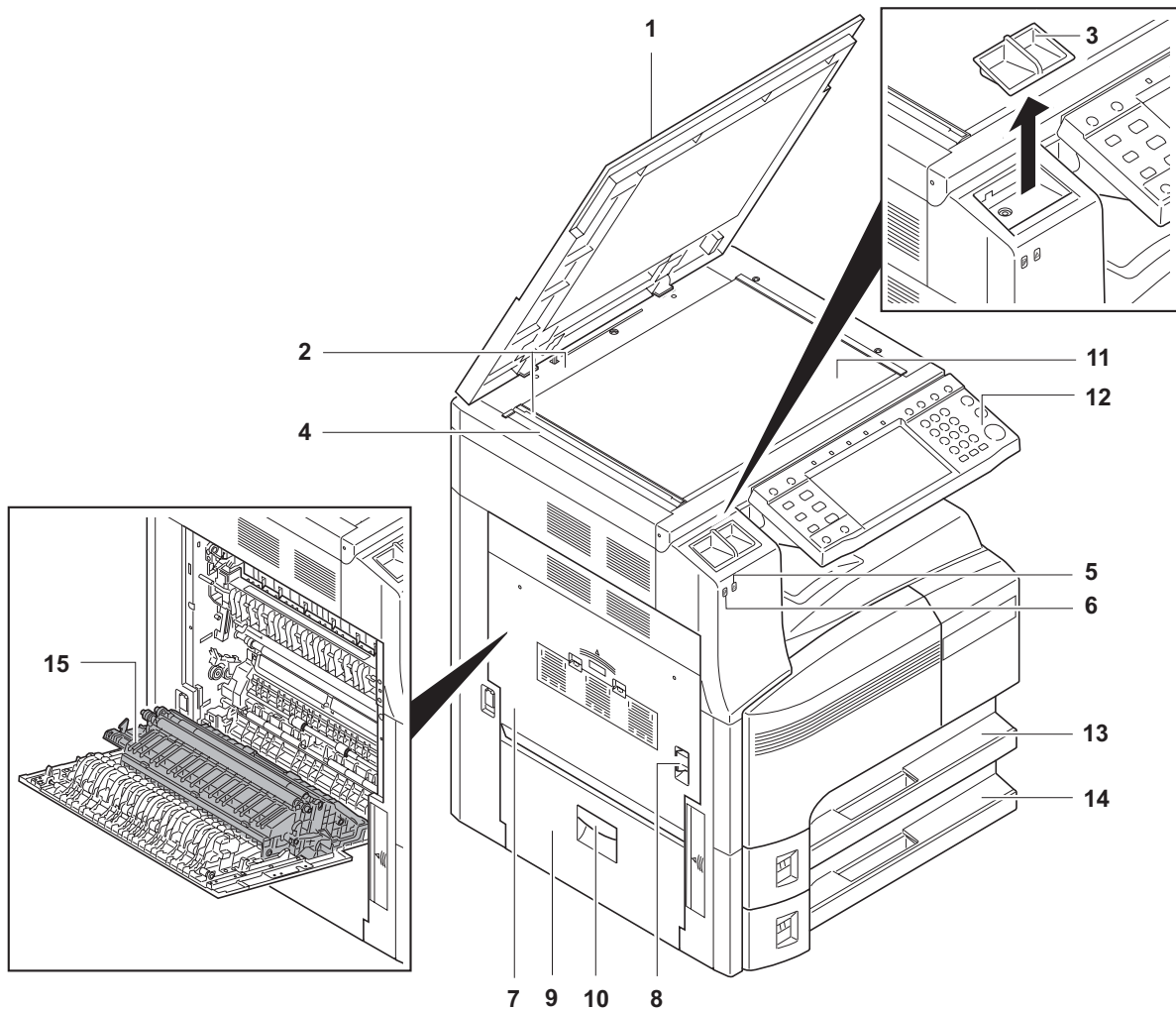

Figure 1-1-1

1. Original cover (option)
2. Original size indicator plates
3. Clip holder
4. Slit glass
5. Attention indicator
6. Receive indicator
7. Left cover 1
8. Left cover 1 lever
9. Left cover 2
10. Left cover 2 handle
11. Contact glass
12. Operation panel
13. Cassette 1
14. Cassette 2
15. Duplex unit

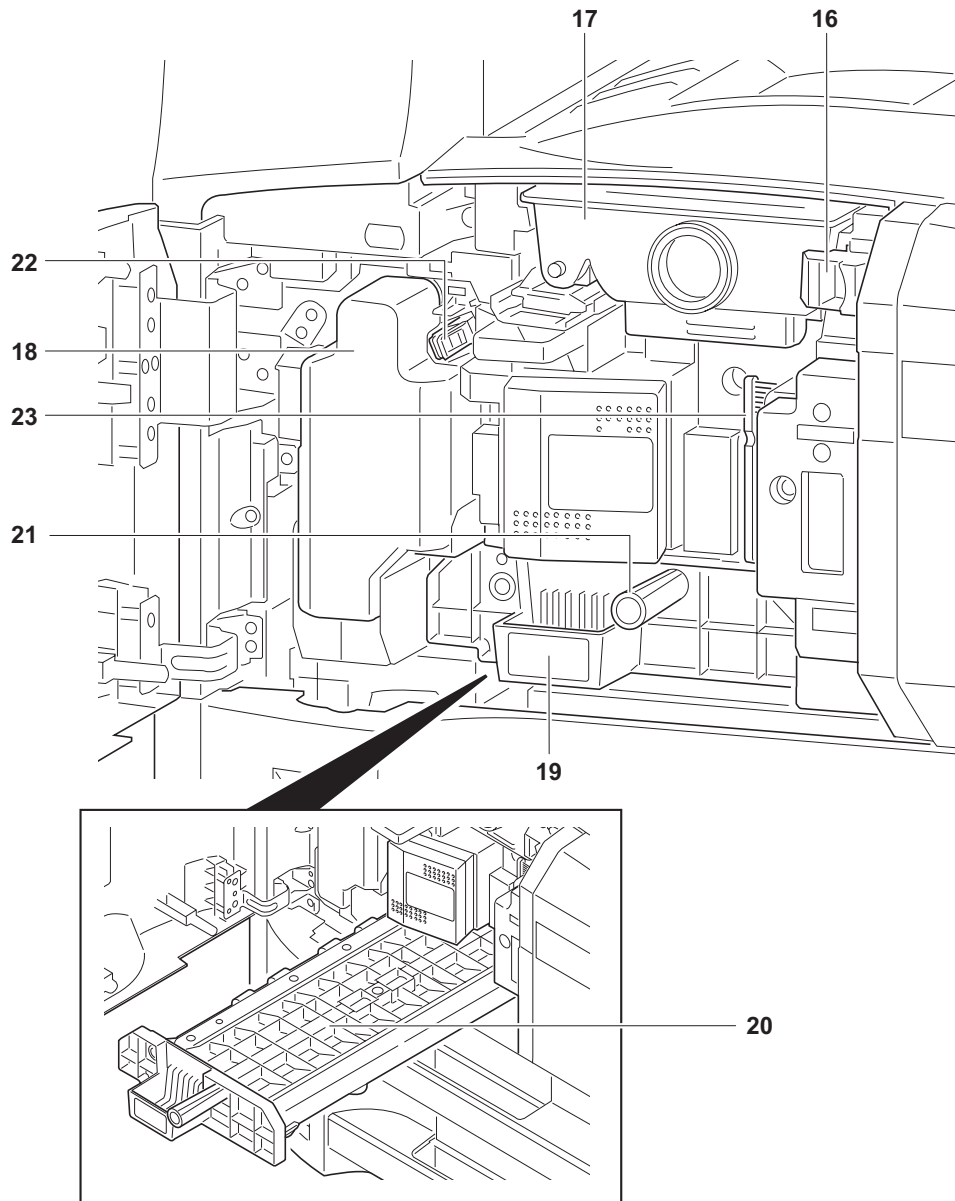

Figure 1-1-2

- 16. Toner container stopper
- 17. Toner container
- 18. Waste toner box
- 19. Paper feed unit (A2)
- 20. Paper feed unit cover (A3)
- 21. Knob
- 22. Cleaner rod
- 23. Cleaning brush

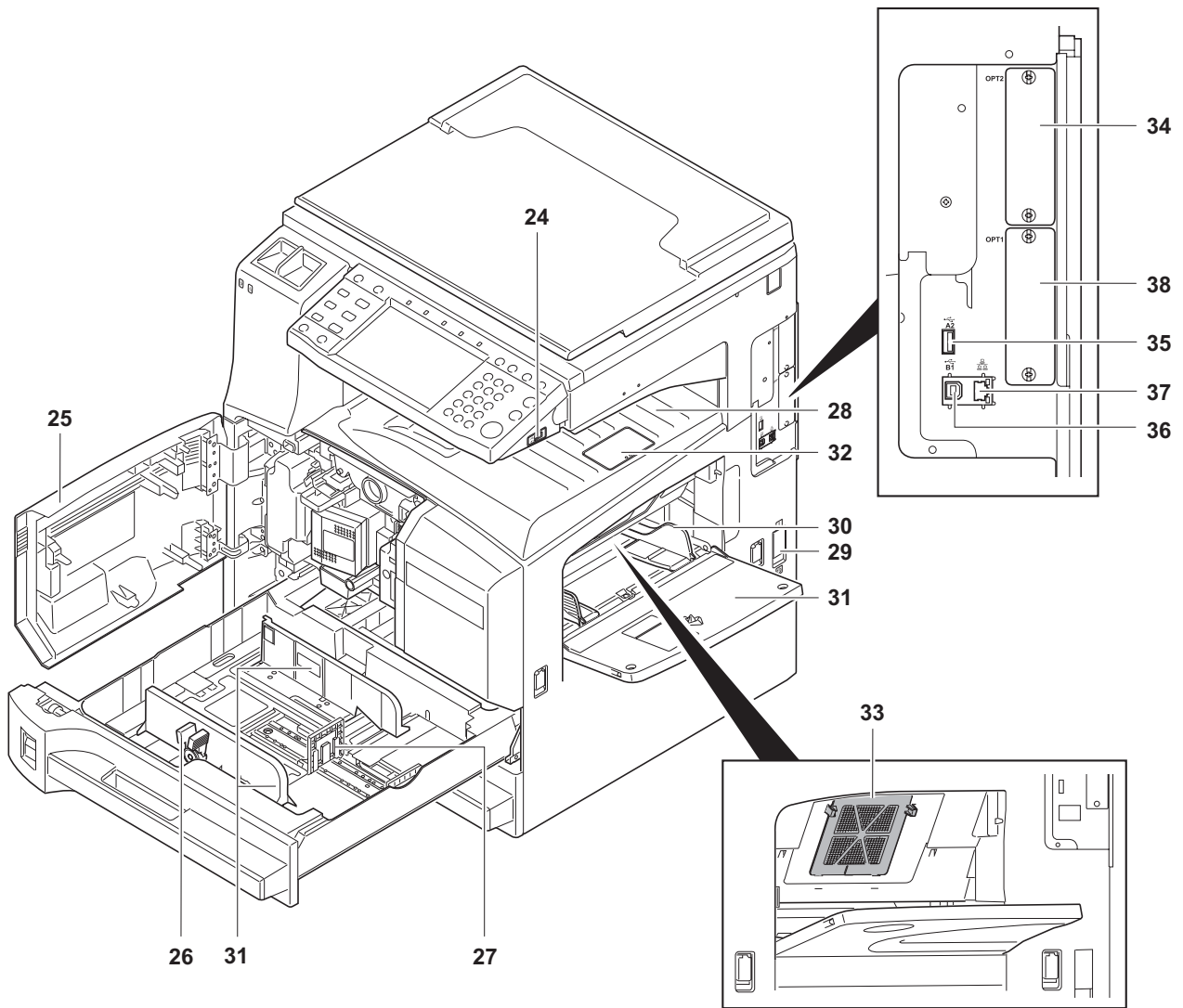

Figure 1-1-3

- 24. USB memory slot (A1)
- 25. Front cover
- 26. Paper width adjusting tab
- 27. Paper length guide
- 28. Top tray
- 29. Main power switch
- 30. Paper width guide
- 31. MP tray (multi purpose tray)
- 32. Output stopper
- 33. Filter (F1)
- 34. Optional interface slot (OPT2)
- 35. USB interface connector (A2)
- 36. USB interface connector (B1)
- 37. Network interface connector
- 38. Optional interface slot (OPT1)

(2) Operation panel

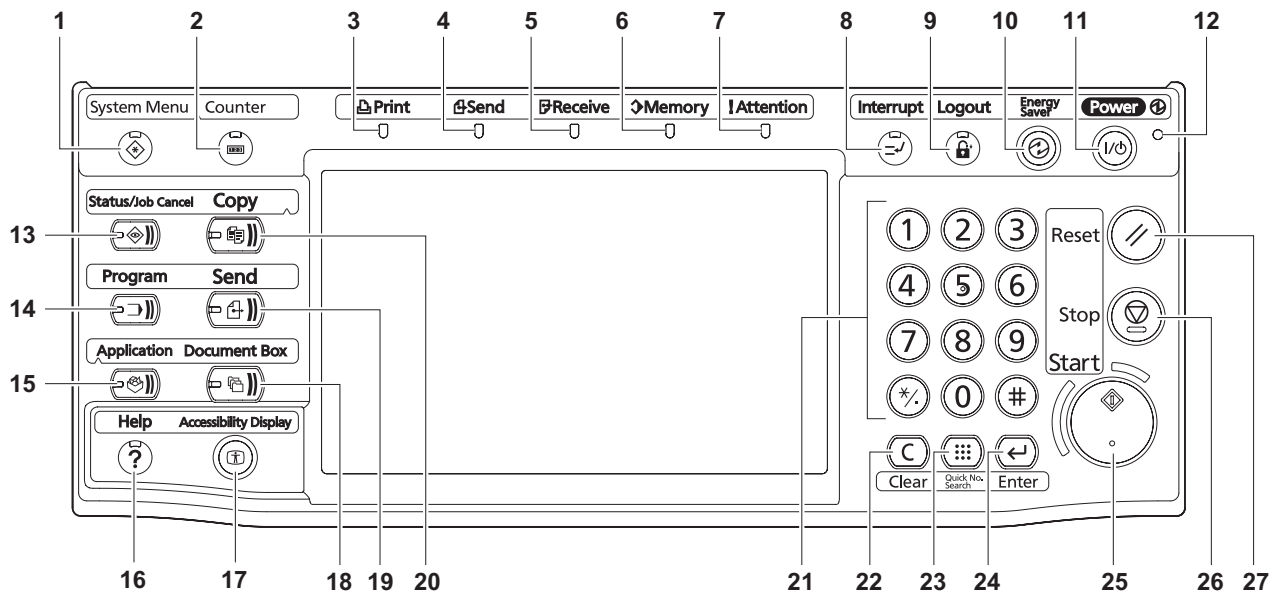

Figure 1-1-4

- | | |
|-------------------------------------|---------------------------------|
| 1. System menu key/indicator | 15. Application key/indicator |
| 2. Counter key/indicator | 16. Help key/indicator |
| 3. Print indicator | 17. Accessibility key/indicator |
| 4. Send indicator | 18. Document box key/indicator |
| 5. Receive indicator | 19. Send key/indicator |
| 6. Memory indicator | 20. Copy key/indicator |
| 7. Attention indicator | 21. Numeric keys |
| 8. Interrupt key/indicator | 22. Clear key |
| 9. Logout key/indicator | 23. Quick No. search key |
| 10. Energy saver key/indicator | 24. Enter key |
| 11. Power key/indicator | 25. Start key/indicator |
| 12. Main power indicator | 26. Stop key |
| 13. Status/Job cancel key/indicator | 27. Reset key |
| 14. Program key/indicator | |

1-1-3 Machine cross section

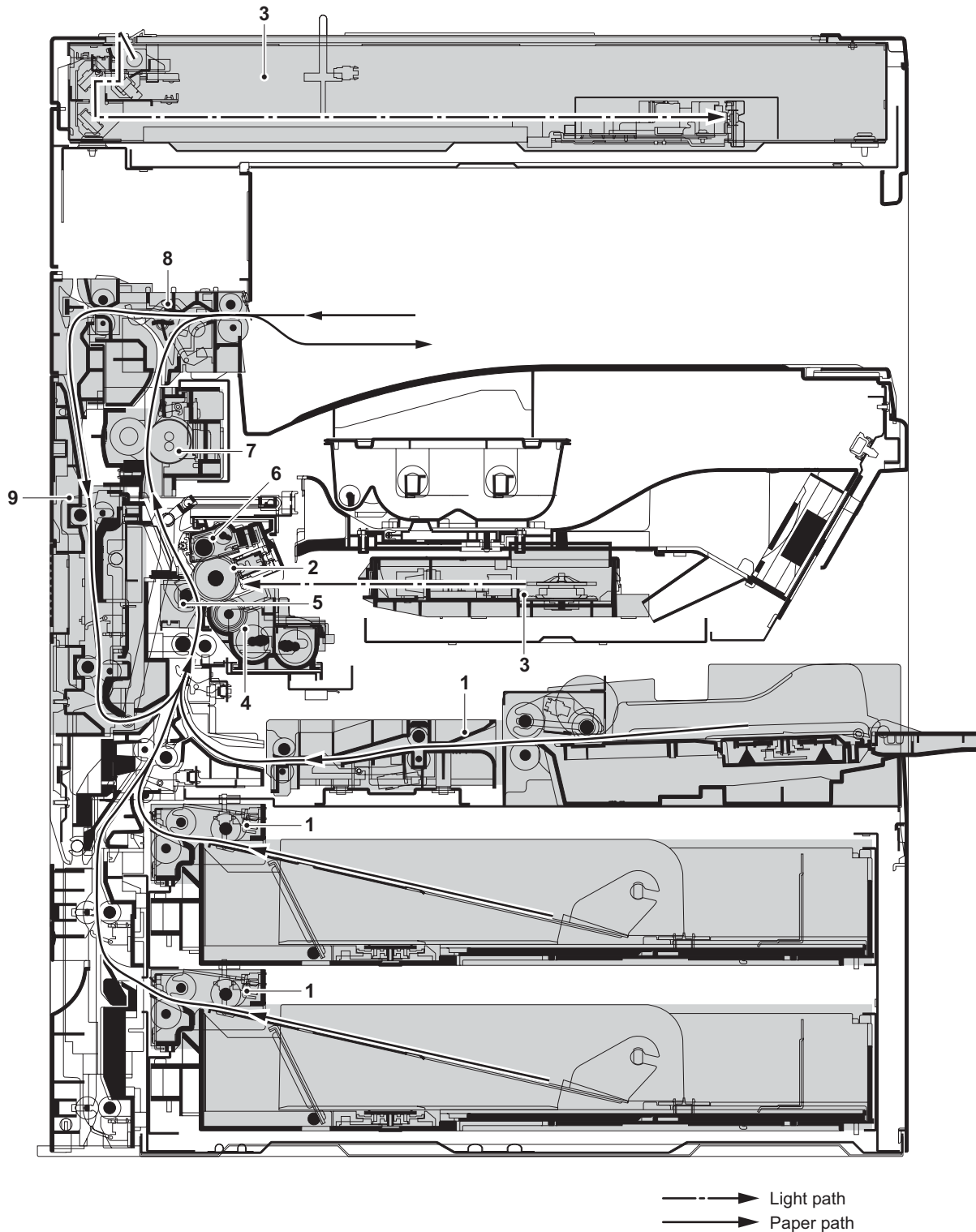

Figure 1-1-5 Machine cross section

- | | |
|------------------------------------|--|
| 1. Paper feed section | 6. Cleaning and charge erasing section |
| 2. Main charging section | 7. Fuser section |
| 3. Optical section | 8. Eject and switchback section |
| 4. Developing section | 9. Duplex section |
| 5. Transfer and separation section | |

This page is intentionally left blank.

1-2-1 Installation environment

1. Temperature: 10 to 32.5°C/50 to 90.5°F
2. Humidity: 15 to 80% RH
3. Power supply: 120 V AC, 11.8 A
220 to 240 V AC, 6.5 A
4. Power source frequency: 50 Hz \pm 0.3%/60 Hz \pm 0.3%
5. Installation location

Avoid direct sunlight or bright lighting. Ensure that the photoconductor will not be exposed to direct sunlight or other strong light when removing paper jams.

Avoid locations subject to high temperature and high humidity or low temperature and low humidity; an abrupt change in the environmental temperature; and cool or hot, direct air.

Avoid places subject to dust and vibrations.

Choose a surface capable of supporting the weight of the machine.

Place the machine on a level surface (maximum allowance inclination: 1°).

Avoid air-borne substances that may adversely affect the machine or degrade the photoconductor, such as mercury, acidic or alkaline vapors, inorganic gasses, NOx, SOx gases and chlorine-based organic solvents.

Select a well-ventilated location.
6. Allow sufficient access for proper operation and maintenance of the machine.

Machine front: 1000 mm/39 3/8" Machine rear: 100 mm/3 15/16"

Machine right: 300 mm/11 13/16" Machine left: 400 mm/15 3/4"

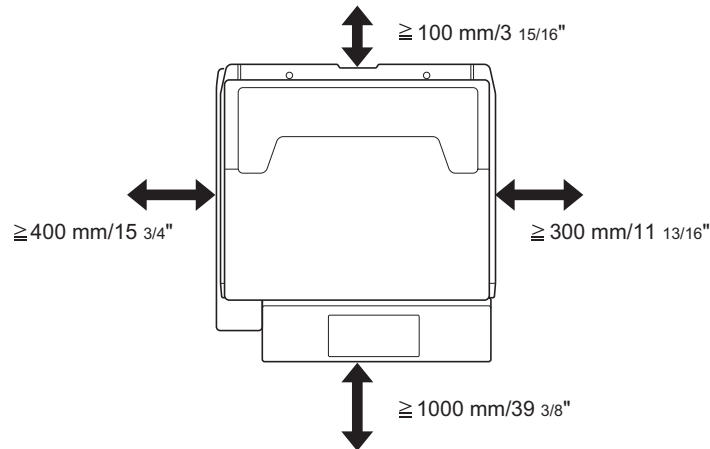
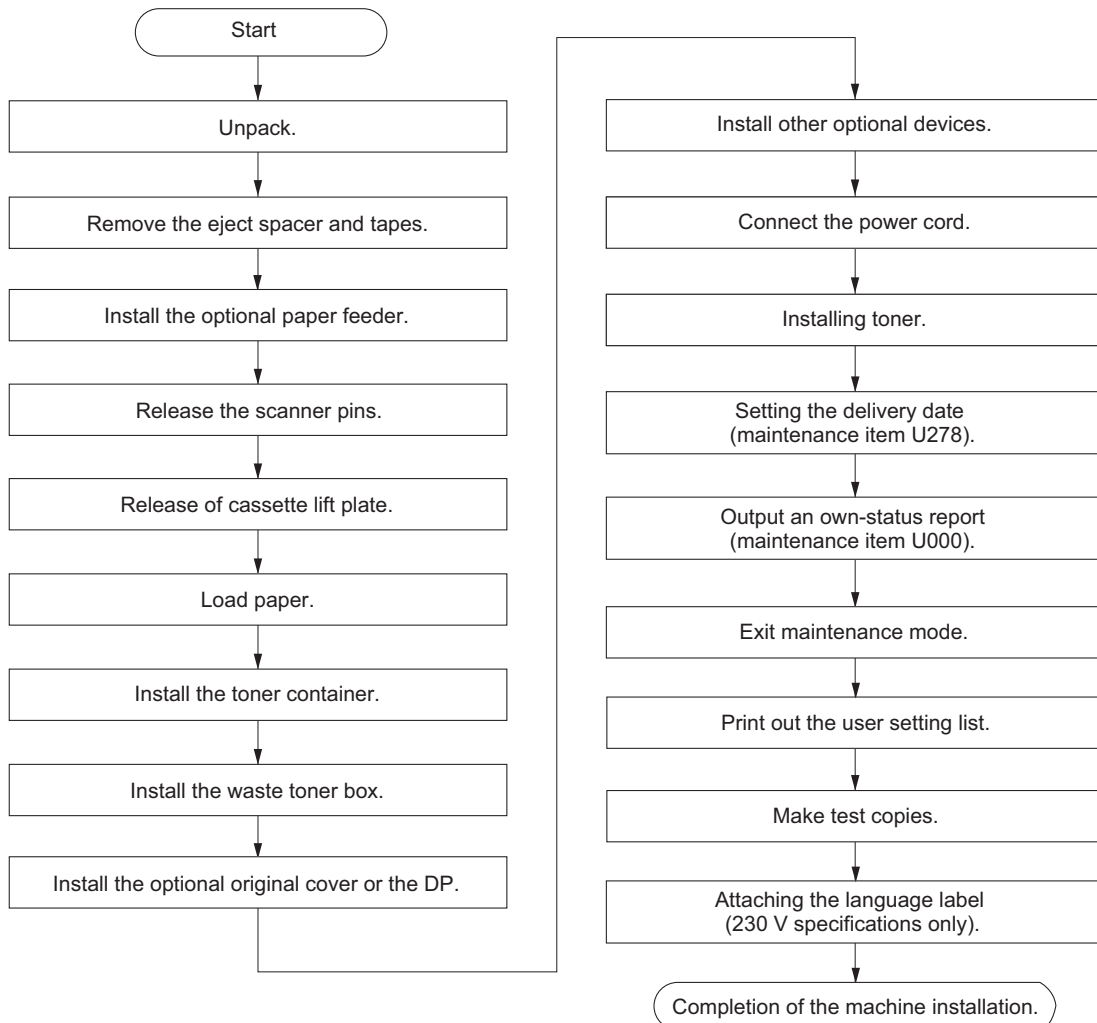

Figure 1-2-1 Installation dimensions

1-2-2 Unpacking and installation

(1) Installation procedure



Moving the machine

When moving the machine, pull out the four carrying handles on the right and left sides and hold them.

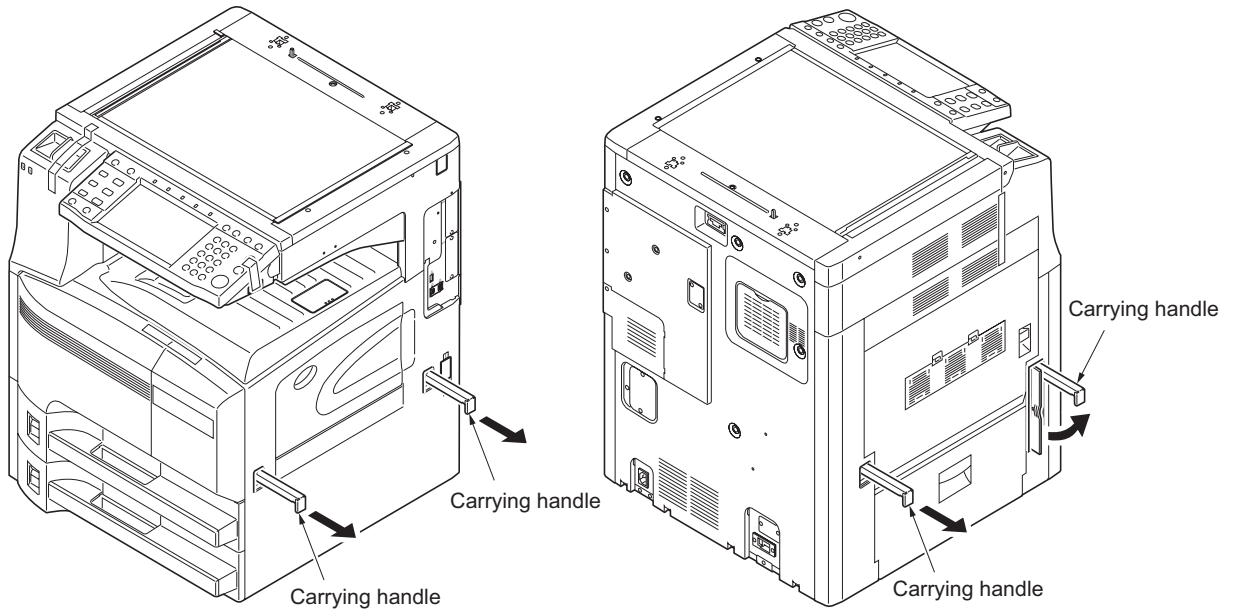

Figure 1-2-2

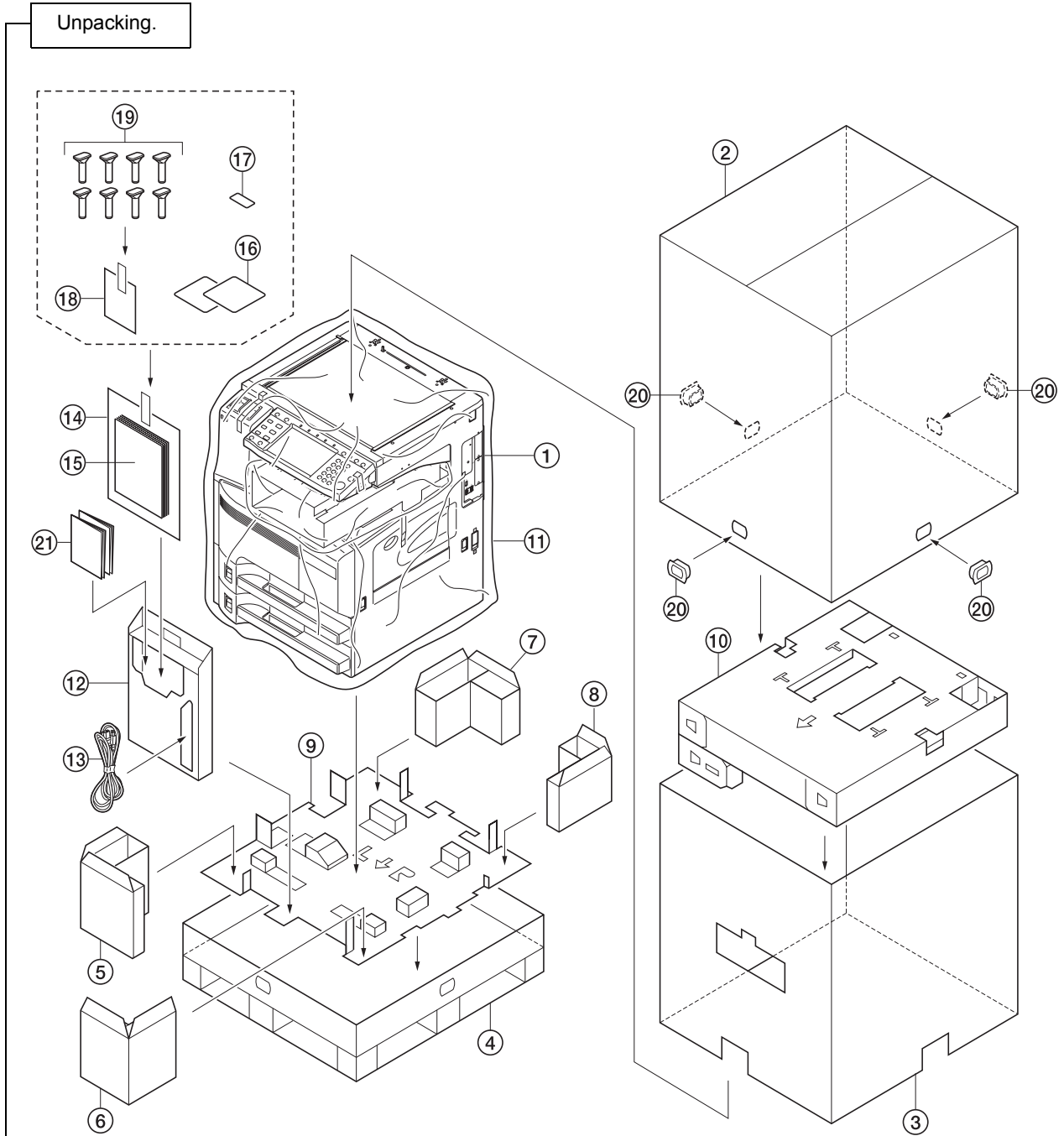

Figure 1-2-3 Unpacking

- | | |
|---------------------------|------------------------|
| 1. Machine | 12. Document tray |
| 2. Outer case | 13. Power cord |
| 3. Inner frame | 14. Plastic bag |
| 4. Skid | 15. Operation guide |
| 5. Bottom front left pad | 16. Size plates |
| 6. Bottom front right pad | 17. USB host label |
| 7. Bottom rear left pad | 18. Plastic bag |
| 8. Bottom rear right pad | 19. Cursor pins |
| 9. Bottom pad | 20. Hinge joints |
| 10. Top pad | 21. Paper storage bags |
| 11. Machine cover | |

Caution: Place the machine on a level surface.

Remove the eject spacer and tapes.

- 1. Remove the eject spacer.

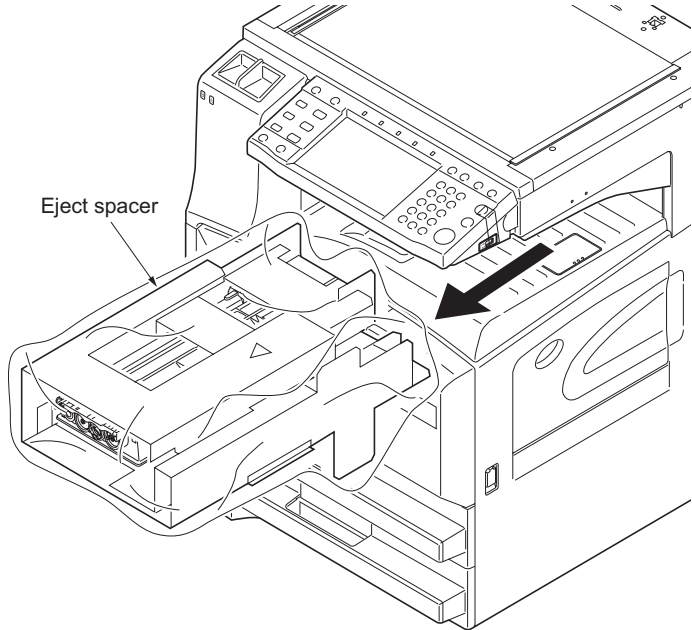

Figure 1-2-4

- 2. Remove four tapes.

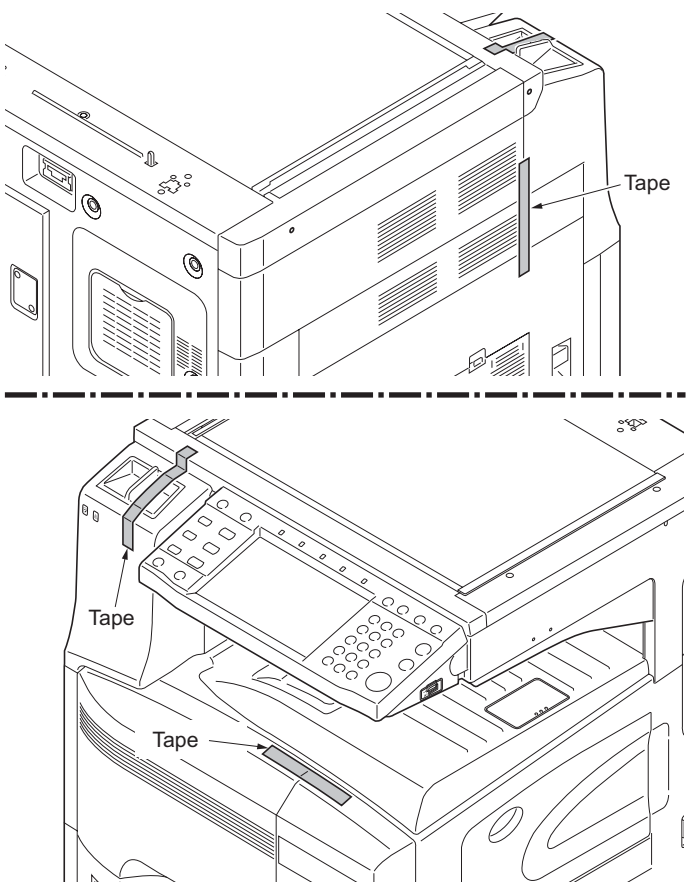

Figure 1-2-5

Install the optional paper feeder.

1. Install the optional paper feeder as necessary.
2. Verify levelness at the four corners of the platen using a level gauge, and adjust the level bolts at the bottom of the machine to optimize levelness.

Release the scanner pins.

1. Remove two tapes.
2. Remove two scanner pins.

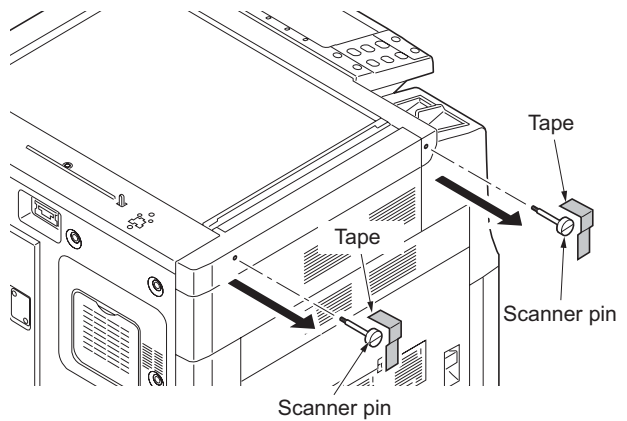

Figure 1-2-6

Release of cassette lift plate.

1. Pull cassette 1 and 2 out. Remove the lift plate stopper from each cassette and attach it to the storage location. When moving the machine, attach the lift plate in original position.

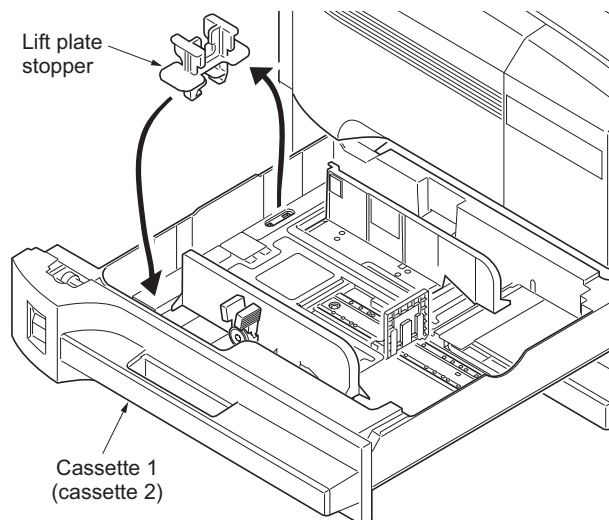

Figure 1-2-7

Load paper.

1. Holding the paper width adjusting tab both ends, move the paper width guides to fit the paper size.

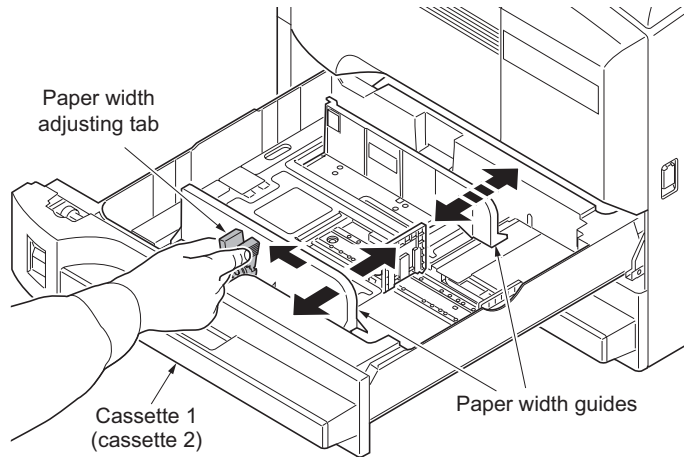

Figure 1-2-8

2. Adjust the paper length guide to fit the paper size.

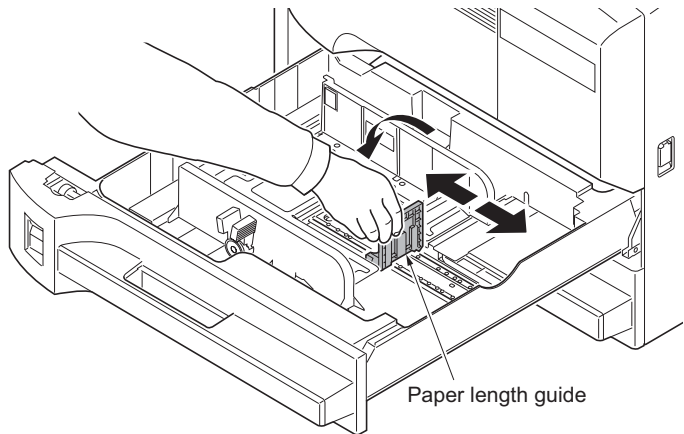

Figure 1-2-9

3. Align the paper flush against the left side of the cassette.

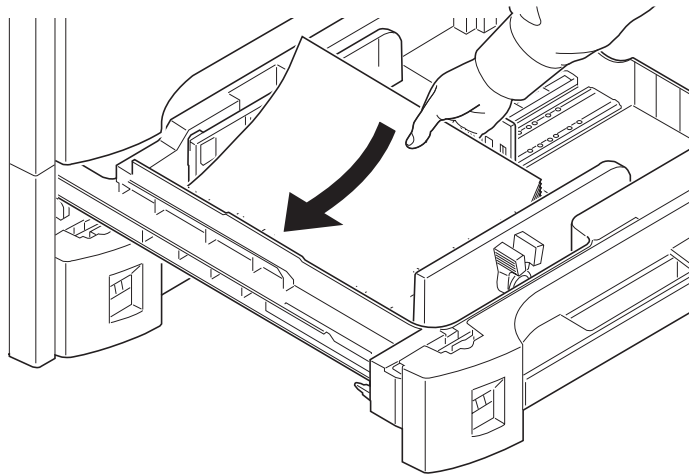

Figure 1-2-10

4. Gently push cassette 1 and 2 back in.

Install the toner container.

1. Open the front cover.
2. Hold the toner container vertically and tap the upper part five times or more.
Turn the toner container upside down and tap the upper part five times or more.

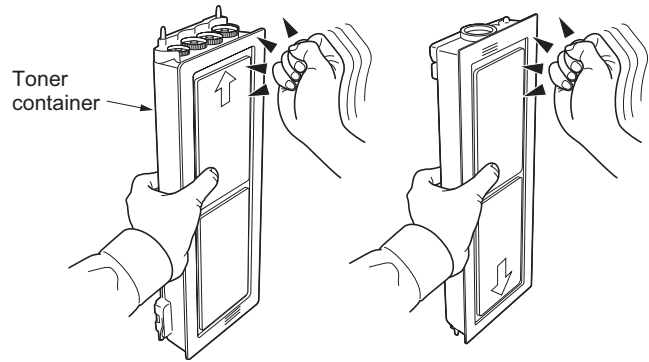

Figure 1-2-11

3. Shake the toner container up and down five times or more.
Turn the toner container upside down and shake it five times or more.

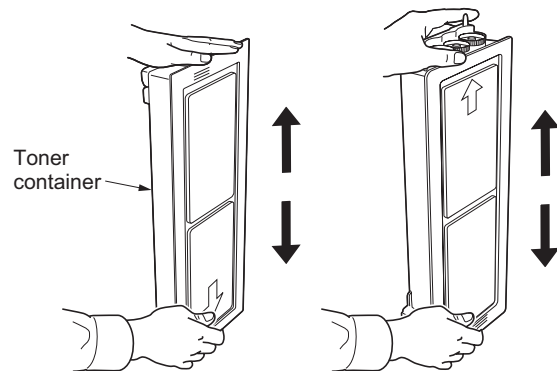

Figure 1-2-12

4. Shake the toner container approximately five times in the horizontal direction to stir toner.

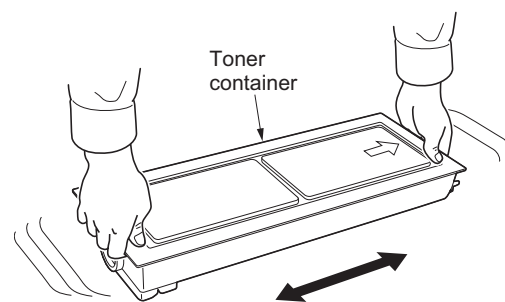

Figure 1-2-13

5. Gently push the toner container into the machine along the rails. Push the container all the way into the machine until it locks in place.

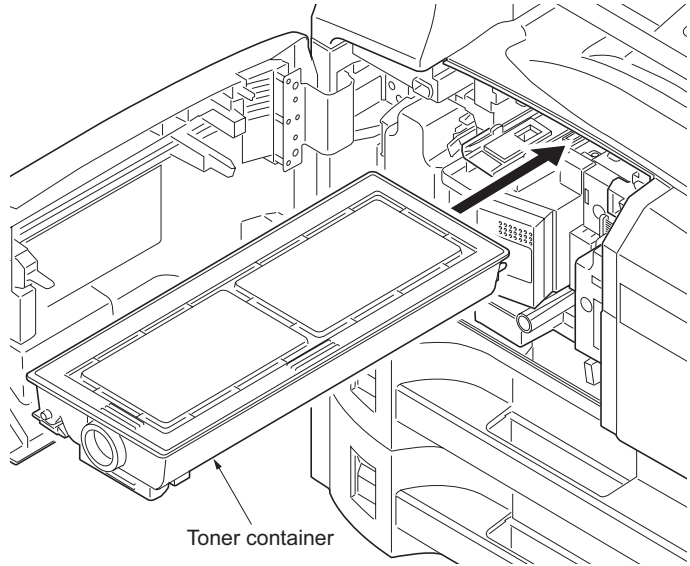

Figure 1-2-14

Install the waste toner box.

1. Install the waste toner box in the machine.
2. Close the front cover.

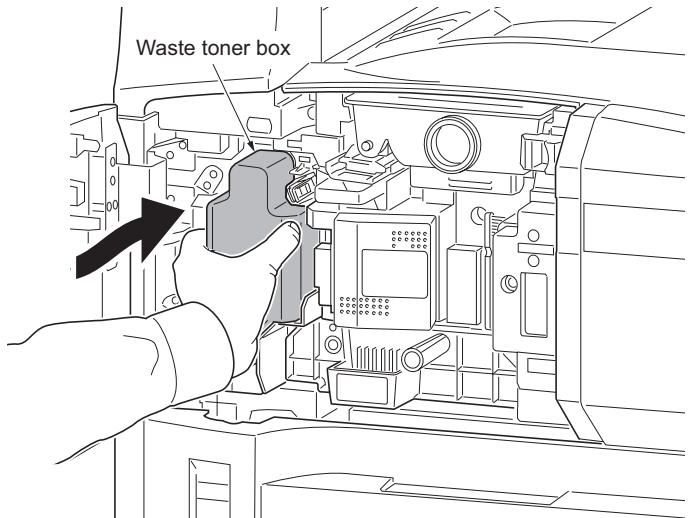

Figure 1-2-15

Install the optional original cover or the DP.

1. Install the optional original cover or DP.

Install other optional devices.

1. Install the optional devices (job separator, built-in finisher, document finisher and/or fax kit etc.) as necessary.

Connect the power cord.

1. Connect the power cord to the connector on the machine.
2. Insert the power plug into the wall outlet.

Installing toner.

1. Turn the main power switch on. Toner installation is started.
2. The drive chain is disengaged when toner installation is completed.
Run maintenance mode U130 if [Add Toner] remains displayed even after the drive chain is disengaged.

Setting the delivery date (maintenance item U278).

1. Press the status/job cancel key. Enter the maintenance mode by entering 10871087 using the numeric keys.
2. Enter 278 using the numeric keys and press the start key.
3. Select [TODAY] and press the start key. The delivery date is set.
4. Press the stop key.

Output an own-status report (maintenance item U000).

1. Enter 000 using the numeric keys and press the start key.
2. Select MAINTENANCE and press the start key to output a list of the current settings of the maintenance items.
3. Press the stop key.

Exit maintenance mode.

1. Enter 001 using the numeric keys and press the start key. The machine exits the maintenance mode.

Print out the user setting list.

1. Select [Report Print] to output the user various setting reports.

Make test copies.

1. Place an original and make test copies.

Attaching the language label (230 V specifications only).

1. According to need, attach the correspond language label.

Completion of the machine installation.

(2) Setting initial copy modes

Factory settings are as follows:

Maintenance item No.	Contents	Factory setting
U253	Switching between double and single counts	DOUBLE COUNT(A3/LEDGER)
U260	Selecting the timing for copy counting	After ejection
U285	Setting service status page	ON
U326	Setting the black line cleaning indication	ON/8
U328	Side ejection setting	OFF
U339	Setting the drum heater ON/OFF	0
U342	Setting the ejection restriction	ON
U343	Switching between duplex/simplex copy mode	OFF

1-2-3 Installing the key counter (option)

Installing the key counter requires the following component:

Key counter (P/N 3025418011)

Key counter set (P/N 302A369708)

Supplied parts of key counter set:

Key counter socket assembly (P/N 3029236241)

Key counter cover (P/N 3066060011)

Key counter mount (P/N 3066060041)

Key counter retainer (P/N 302GR03020)

Key counter cover retainer (P/N 302GR03010)

Two (2) Edgings (P/N 7YZM210006++H01)

One (1) Band (P/N M21AH010)

One (1) M3 × 8 tap-tight P screw (P/N 5MBTPB3008PW++R)

Two (2) M4 × 10 tap-tight P screws (P/N 5MBTPB4010PW++R)

Two (2) M4 × 10 tap-tight S screws (P/N 5MBTPB4010TW++R)

Two (2) M3 × 6 bronze flat-head screws (P/N 7BB003306H)

One (1) M4 × 20 tap-tight S screw (P/N 7BB100420H)

One (1) M3 bronze nut (P/N 7BC1003055++H01)

One (1) M3 × 8 bronze binding screw (P/N B1B03080)

One (1) M4 × 30 tap-tight S screw (P/N B1B54300)

Five (5) M4 × 6 chrome TP screws (P/N B4A04060)

Two (2) M4 × 10 chrome TP screws (P/N B4A04100)

Procedure

1. Press the power key on the operation panel to off. Make sure that the power indicator and the memory indicator are off before turning off the main power switch. And then unplug the power cable from the wall outlet.
2. Fit the key counter socket assembly to the key counter retainer using two screws and nut.
3. Fit the key counter mount to the key counter cover using two screws.
4. Fit the key counter retainer to the key counter mount using two screws.

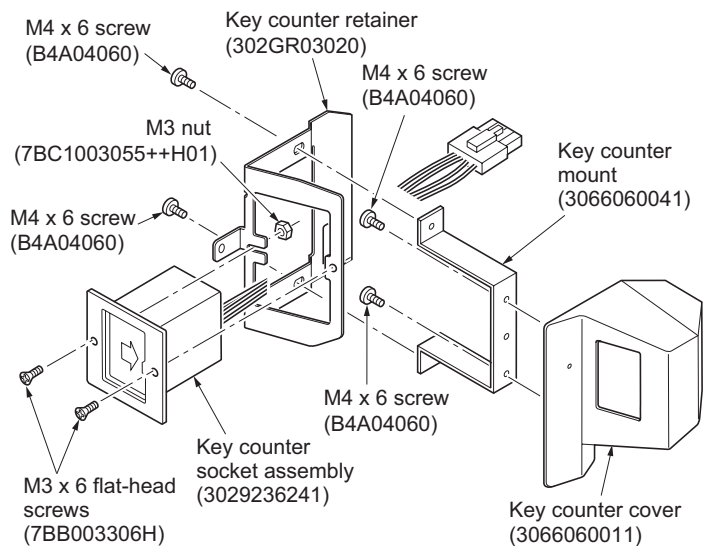

Figure 1-2-16

5. Remove two screws and remove the scanner right cover.
6. Cut out the aperture plate on the upper right cover using nippers.
7. Pull the key counter wire out.

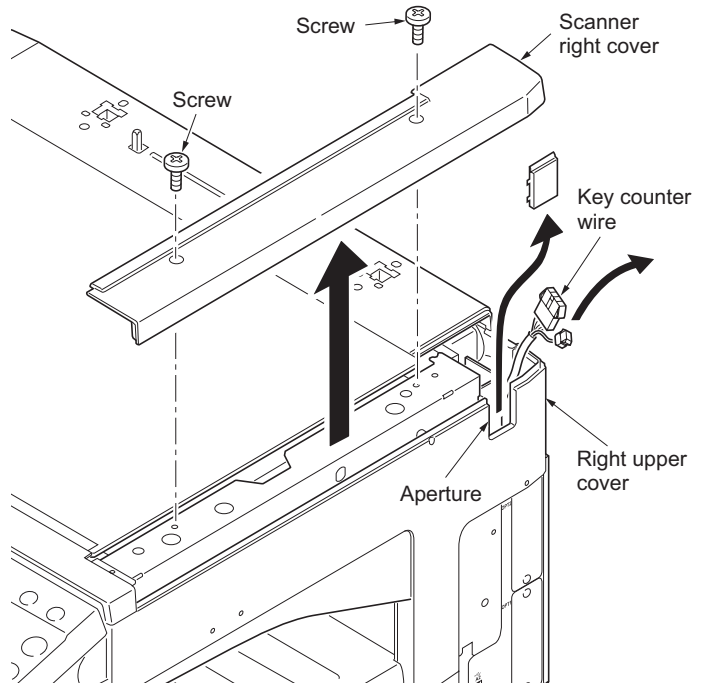

Figure 1-2-17

8. Seat the hook of the key counter cover retainer in the aperture in the right upper cover.
9. Fit the key counter cover retainer using two screws.

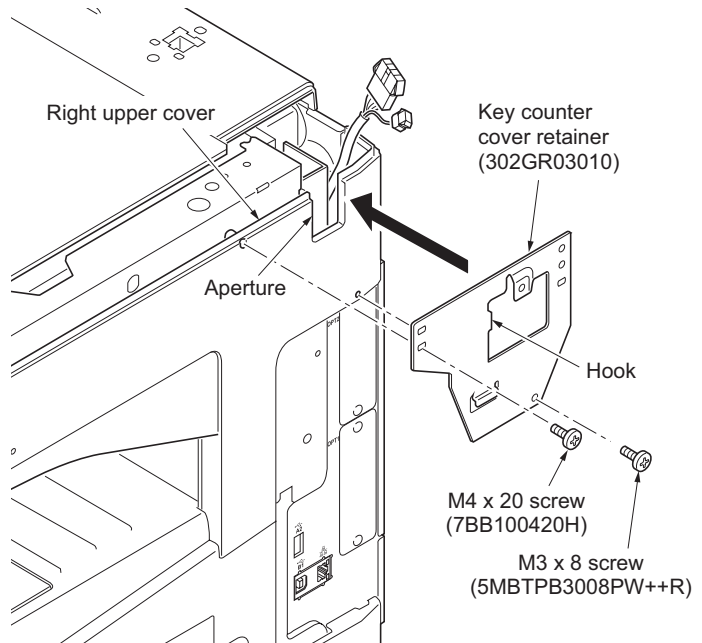

Figure 1-2-18

10. Pass the 4-pin connector of the key counter signal cable through the aperture in the key counter cover retainer.
11. Insert the 4-pin connector of the key counter signal cable into the 4-pin connector of the key counter wire.
12. Hook the square hole on the key counter cover onto the key counter cover retainer.
13. Fit the key counter unit using the screw.

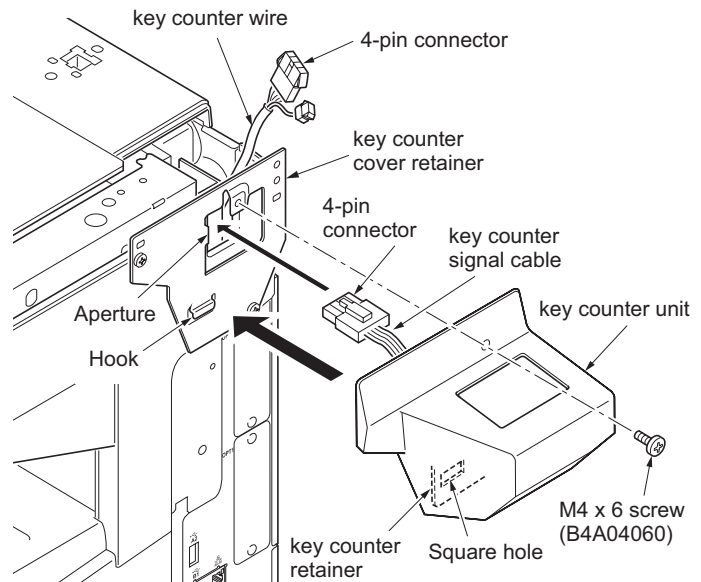

Figure 1-2-19

14. Seat the 2-pin and the 4-pin connectors between the right upper cover and the partition plate.
15. Refit the scanner right cover. Be sure not that the 2-pin connector is not pinched between the scanner right cover and the upper right cover.

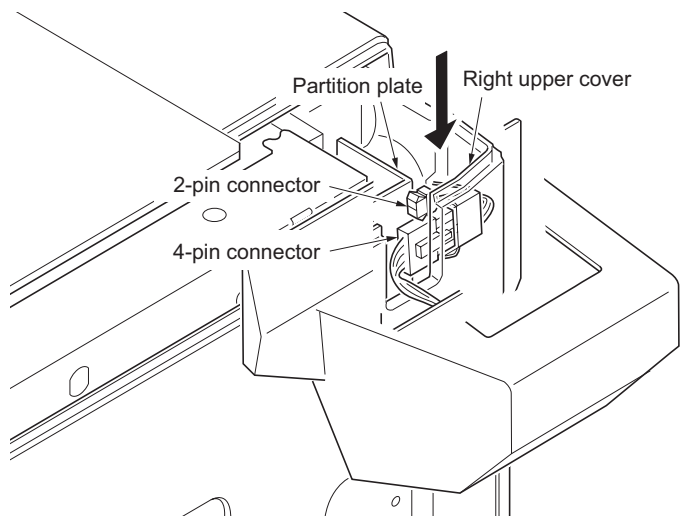

Figure 1-2-20

16. Insert the key counter into the key counter socket assembly.
17. Turn the main power switch on and enter the maintenance mode.
18. Run maintenance item U204 and select [KEY COUNTER].
19. Exit the maintenance mode.
20. Check that the message requesting the key counter to be inserted is displayed on the touch panel when the key counter is pulled out.
21. Check that the counter counts up as prints are made.

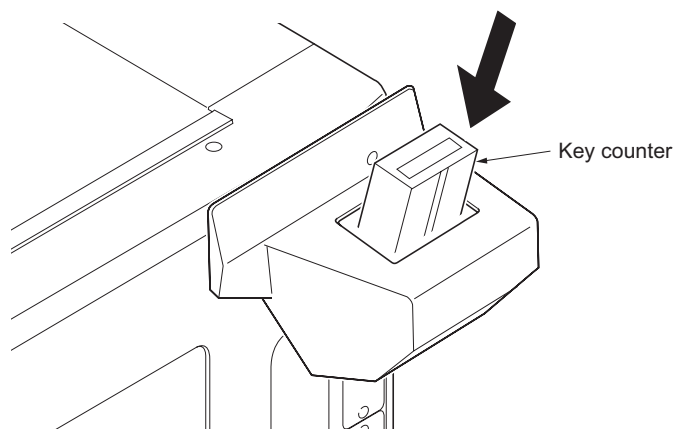

Figure 1-2-21

1-3-1 Maintenance mode

The machine is equipped with a maintenance function which can be used to maintain and service the machine.

(1) Executing a maintenance item



(2) Maintenance modes item list

Section	Item No.	Content of maintenance item	Initial setting*
General	U000	Outputting an own-status report	-
	U001	Exiting the maintenance mode	-
	U002	Setting the factory default data	-
	U003	Setting the service telephone number	*****
	U004	Displaying the machine number	-
	U019	Displaying the ROM version	-
Initialization	U021	Initializing counters and mode settings	-
	U024	HDD formatting	-
Drive, paper feed, paper conveying and cooling system	U030	Checking motor operation	-
	U031	Checking switches for paper conveying	-
	U032	Checking clutch operation	-
	U033	Checking solenoid operation	-
	U034	Adjusting the print start timing Adjusting the leading edge registration Adjusting the center line	0/0/0/0/0/0 0/0/0/0/0/0
	U035	Setting the printing area for folio paper Length/Width	330/210
	U037	Checking the operation of the fan motors	-
	U051	Adjusting the deflection in the paper	0/50/50/40/10
	U053	Setting the adjustment of the motor speed	0/-1/0/-2/2/-8/0
	U055	Setting the motor periodic drive	OFF
	U059	Setting fan mode	45
Optical	U061	Turning the exposure lamp on	-
	U063	Adjusting the shading position	0
	U065	Adjusting the scanner magnification Main scanning direction/Auxiliary scanning direction	0/0
	U066	Adjusting the scanner leading edge registration	0/0
	U067	Adjusting the scanner center line	0/0
	U068	Adjusting the scanning position for originals from the DP	0/0
	U070	Adjusting the DP magnification	0/0
	U071	Adjusting the DP scanning timing	0/0/0/0
	U072	Adjusting the DP center line	0/0
	U073	Checking scanner operation	-
	U074	Adjusting the DP input light luminosity	0
	U080	Setting the economy mode	60
	U081	Adjusting the correct exposure	0/0/0
	U087	Setting DP reading position modification operation	125/125/125
	U089	Outputting a MIP-PG pattern	-
	U093	Setting the exposure density gradient	0/0/0/0/0
	U099	Adjusting original size detection	40/30/20/40/30/20/40/30/20/ 19/19/19/185

*: Factory initial setting, *1: The item initialized for executing U021

Section	Item No.	Content of maintenance item	Initial setting*
High voltage	U100	Setting the main high voltage	-
	U101	Setting the other high voltages	26/58/50/89/1/ 115/91/68/40/92
	U110	Checking the drum count	-
	U114	Setting separation charger mode	MODE3
	U117	Checking the drum number	-
	U118	Displaying the drum history	-
Developing	U130	Initial setting for the developing unit	-
	U135	Checking toner motor operation	100/30/100
	U136	Setting toner near end mode	OFF*1
	U144	Setting toner loading operation	0/5/30
	U155	Checking sensors for toner	-
	U157	Checking the developing drive time	-
	U158	Checking the developing count	-
Fuser and cleaning	U161	Setting the fuser control temperature	110/165/155/165/0
	U163	Resetting the fuser problem data	-
	U167	Checking/clearing the fuser counts	-
	U193	Setting the fuser drive control	ON
	U198	Setting the fuser phase control	ON
	U199	Checking the fuser temperature	-
Operation panel and support equipment	U200	Turning all LEDs on	-
	U201	Initializing the touch panel	-
	U202	Setting the KMAS host monitoring system	-
	U203	Checking DP operation	-
	U204	Setting the presence or absence of a key card or key counter	OFF/KEY-DEVICE*1
	U206	Setting the presence or absence of the coin vender	-
	U207	Checking the operation panel keys	-
	U221	Setting the USB host lock function	OFF*1
	U222	Setting the IC card type	-
	U223	Operation panel lock	Unlock*1
	U224	Panel sheet extension	-
	U233	Limiting job separator output	MODE0
	U236	Setting the limit for the ejection section of the built-in finisher	OFF*1
	U243	Checking the operation of the DP motors	-
	U244	Checking the DP switches	-
	U245	Checking messages	-
	U246	Setting the finisher	0/0/0
U247	Setting the paper feed device	-	

*: Factory initial setting, *1: The item initialized for executing U021

Section	Item No.	Content of maintenance item	Initial setting*
Mode setting	U250	Setting the maintenance cycle	-
	U251	Checking/clearing the maintenance count	-
	U252	Setting the destination	-
	U253	Switching between double and single counts	DOUBLE COUNT (A3/LEDGER) ^{*1}
	U260	Selecting the timing for copy counting	After ejection
	U265	Setting OEM purchaser code	-
	U278	Setting the delivery date	-
	U285	Setting service status page	ON
	U326	Setting the black line cleaning indication	ON/8 ^{*1}
	U328	Side ejection setting	OFF ^{*1}
	U332	Setting the size conversion factor	1.0 ^{*1}
	U339	Setting the drum heater ON/OFF	0 ^{*1}
	U341	Specific paper feed location setting for printing function	-
	U342	Setting the ejection restriction	ON ^{*1}
	U343	Switching between duplex/simplex copy mode	OFF ^{*1}
U345	Setting the value for maintenance due indication	0 ^{*1}	
Image processing	U402	Adjusting margins of image printing	4.0/3.0/3.0/3.9/4.0/4.0
	U403	Adjusting margins for scanning an original on the platen	2.0/2.0/2.0/2.0
	U404	Adjusting margins for scanning an original from the DP	3.0/2.5/3.0/4.0
	U407	Adjusting the leading edge registration for memory image printing	0
	U410	Adjusting the halftone automatically	-
	U411	Adjusting the scanner automatically	-
	U425	Setting the target	-
	U470	Setting the JPEG compression ratio System Copy Send	90/90 ^{*1} 90/90/90/90 ^{*1} 30/40/51/70/90 ^{*1} 30/40/51/70/90 ^{*1} 30/40/51/70/90 ^{*1} 15/25/60 ^{*1} 15/25/60 ^{*1}
	U473	Adjusting laser power output	0
U485	Setting the image processing mode	1/0 ^{*1}	
Network scanner	U510	Setting the enterprise mode	-

*: Factory initial setting, *1: The item initialized for executing U021

Section	Item No.	Content of maintenance item	Initial setting*
Others	U901	Checking/clearing copy counts by paper feed locations	-
	U903	Checking/clearing the paper jam counts	-
	U904	Checking/clearing the service call counts	-
	U905	Checking/clearing counts by optional devices	-
	U906	Resetting partial operation control	-
	U908	Checking the total counter value	-
	U910	Clearing the black ratio data	-
	U911	Checking copy counts by paper sizes	-
	U917	Setting backup data reading/writing	-
	U920	Checking the copy counts	-
	U927	Clearing the all copy counts and machine life counts (one time only)	-
	U928	Checking machine life counts	-
	U931	Setting the automatic toner install	OFF
	U935	Relay board maintenance	MODE0*1
	U942	Setting of deflection for feeding from DP	0/0
	U964	Checking of log	-
	U969	Checking of toner area code	-
	U977	Data capture mode	-
	U984	Checking the developing unit number	-
	U985	Displaying the developing unit history	-
	U989	HDD scandisk	-
U991	Checking the scanner count	-	

*: Factory initial setting, *1: The item initialized for executing U021

(3) Contents of the maintenance mode items

Maintenance item No.	Description																																
U000	<p>Outputting an own-status report</p> <p>Description Outputs lists of the current settings of the maintenance items, and paper jam and service call occurrences. Outputs the event log or service status page. Also sends output data to the USB memory. Printing a report is disabled either when a job is remaining in the buffer or when [Pause All Print Jobs] is pressed to halt printing.</p> <p>Purpose To check the current setting of the maintenance items, or paper jam or service call occurrences. Before initializing or replacing the backup RAM, output a list of the current settings of the maintenance items to reenter the settings after initialization or replacement.</p> <p>Method</p> <ol style="list-style-type: none"> Press the start key. Select the item to be output. <table border="1" style="width: 100%; border-collapse: collapse;"> <thead> <tr> <th style="text-align: left;">Display</th> <th style="text-align: left;">Output list</th> </tr> </thead> <tbody> <tr> <td>MAINTENANCE</td> <td>List of the current settings of the maintenance modes</td> </tr> <tr> <td>USER STATUS</td> <td>Outputs the user status page</td> </tr> <tr> <td>SERVICE STATUS</td> <td>Outputs the service status page</td> </tr> <tr> <td>EVENT</td> <td>Outputs the event log</td> </tr> <tr> <td>NETWORK STATUS</td> <td>Outputs the network status page</td> </tr> <tr> <td>ALL</td> <td>Outputs the all reports</td> </tr> </tbody> </table> <ol style="list-style-type: none"> Press the start key. The interrupt print mode is entered and a list is output. When A4/Letter paper is available, a report of this size is output. If not, specify the paper feed location. When output is complete, the screen for selecting an item is displayed. The output status is displayed. <table border="1" style="width: 100%; border-collapse: collapse;"> <thead> <tr> <th style="text-align: left;">Display</th> <th style="text-align: left;">Description</th> </tr> </thead> <tbody> <tr> <td>READY</td> <td>Standing by for output (including while outputting other reports)</td> </tr> <tr> <td>ACTIVE</td> <td>Performing output processing</td> </tr> <tr> <td>COMPLETE</td> <td>Output processing completed normally</td> </tr> <tr> <td>ERROR</td> <td>Output processing terminated with an error</td> </tr> </tbody> </table> <p>Method: Send to the USB memory</p> <ol style="list-style-type: none"> Press the power key on the operation panel, and after verifying the main power indicator has gone off, switch off the main power switch. Insert USB memory in USB memory slot. Turn the main power switch on. Enter the maintenance item. Press the start key. Select the item to be send. Select [TEXT] or [HTML]. <table border="1" style="width: 100%; border-collapse: collapse;"> <thead> <tr> <th style="text-align: left;">Display</th> <th style="text-align: left;">Output list</th> </tr> </thead> <tbody> <tr> <td>Print</td> <td>Outputs the report</td> </tr> <tr> <td>To USB (TEXT)</td> <td>Sends output data to the USB memory (text type)</td> </tr> <tr> <td>To USB (HTML)</td> <td>Sends output data to the USB memory (HTML type)</td> </tr> </tbody> </table> <ol style="list-style-type: none"> Press the start key. Output will be sent to the USB memory. 	Display	Output list	MAINTENANCE	List of the current settings of the maintenance modes	USER STATUS	Outputs the user status page	SERVICE STATUS	Outputs the service status page	EVENT	Outputs the event log	NETWORK STATUS	Outputs the network status page	ALL	Outputs the all reports	Display	Description	READY	Standing by for output (including while outputting other reports)	ACTIVE	Performing output processing	COMPLETE	Output processing completed normally	ERROR	Output processing terminated with an error	Display	Output list	Print	Outputs the report	To USB (TEXT)	Sends output data to the USB memory (text type)	To USB (HTML)	Sends output data to the USB memory (HTML type)
Display	Output list																																
MAINTENANCE	List of the current settings of the maintenance modes																																
USER STATUS	Outputs the user status page																																
SERVICE STATUS	Outputs the service status page																																
EVENT	Outputs the event log																																
NETWORK STATUS	Outputs the network status page																																
ALL	Outputs the all reports																																
Display	Description																																
READY	Standing by for output (including while outputting other reports)																																
ACTIVE	Performing output processing																																
COMPLETE	Output processing completed normally																																
ERROR	Output processing terminated with an error																																
Display	Output list																																
Print	Outputs the report																																
To USB (TEXT)	Sends output data to the USB memory (text type)																																
To USB (HTML)	Sends output data to the USB memory (HTML type)																																

Maintenance item No.	Description																																																																																																																																																																																																											
U000	<p data-bbox="272 293 384 322">Event log</p> <div data-bbox="325 383 1366 1480" style="border: 1px solid black; padding: 10px;"> <p data-bbox="352 409 563 454">Event Log</p> <p data-bbox="352 456 414 483">MFP</p> <p data-bbox="1145 472 1326 499">(2) 9/Aug/2009 08:40</p> <p data-bbox="336 517 783 544">(1) Firmware version 2K5_2000.000.000 2009.08.09</p> <p data-bbox="994 499 1334 544">(3) [XXXXXXXX] (4) [XXXXXXXX] (5) [XXXXXXXX]</p> <hr/> <div style="display: flex; justify-content: space-between;"> <div data-bbox="336 568 536 595">(7) Paper Jam Log</div> <div data-bbox="911 568 1118 595">(8) Service Call Log</div> </div> <table border="0" style="width: 100%; border-collapse: collapse;"> <thead> <tr> <th style="width: 10%;">#</th> <th style="width: 15%;">Count.</th> <th style="width: 40%;">Event Descriptions</th> <th style="width: 10%;">#</th> <th style="width: 15%;">Count.</th> <th style="width: 10%;">Service Code</th> </tr> </thead> <tbody> <tr> <td>16</td> <td>9876543</td> <td>10.01.08.01.01</td> <td>8</td> <td>7881214</td> <td>01.0060</td> </tr> <tr> <td>15</td> <td>666554</td> <td>10.01.08.01.02</td> <td>7</td> <td>578944</td> <td>01.0120</td> </tr> <tr> <td>14</td> <td>4988</td> <td>10.01.08.01.01</td> <td>6</td> <td>5296</td> <td>01.4000</td> </tr> <tr> <td>13</td> <td>4988</td> <td>10.01.08.01.02</td> <td>5</td> <td>5295</td> <td>01.3100</td> </tr> <tr> <td>12</td> <td>4988</td> <td></td> <td>4</td> <td>2099</td> <td>01.2000</td> </tr> <tr> <td>11</td> <td>4988</td> <td></td> <td>3</td> <td>1054</td> <td>01.2000</td> </tr> <tr> <td>10</td> <td>1103</td> <td></td> <td>2</td> <td>809</td> <td>01.2200</td> </tr> <tr> <td>9</td> <td>1103</td> <td></td> <td>1</td> <td>30</td> <td>01.2500</td> </tr> <tr> <td>8</td> <td>1103</td> <td>12.03.08.01.01</td> <td></td> <td></td> <td></td> </tr> <tr> <td>7</td> <td>1103</td> <td>12.03.08.01.01</td> <td></td> <td></td> <td></td> </tr> <tr> <td>6</td> <td>1027</td> <td>12.03.08.01.01</td> <td></td> <td></td> <td></td> </tr> <tr> <td>5</td> <td>1027</td> <td>12.03.0A.01.01</td> <td></td> <td></td> <td></td> </tr> <tr> <td>4</td> <td>1027</td> <td>12.03.08.01.01</td> <td></td> <td></td> <td></td> </tr> <tr> <td>3</td> <td>1027</td> <td>12.03.08.01.02</td> <td></td> <td></td> <td></td> </tr> <tr> <td>2</td> <td>550</td> <td>12.03.0A.01.01</td> <td></td> <td></td> <td></td> </tr> <tr> <td>1</td> <td>28</td> <td>12.03.08.01.01</td> <td></td> <td></td> <td></td> </tr> </tbody> </table> <div style="margin-top: 10px;"> <p data-bbox="544 707 836 786" style="border: 1px solid black; padding: 5px; display: inline-block;"> 10.01.08.01.01 (a) (b) (c) (d) (e) </p> </div> <div style="margin-top: 10px;"> <p data-bbox="911 804 1126 831">(9) Maintenance Log</p> <table border="0" style="width: 100%; border-collapse: collapse;"> <thead> <tr> <th style="width: 10%;">#</th> <th style="width: 15%;">Count.</th> <th style="width: 75%;">Item</th> </tr> </thead> <tbody> <tr> <td>8</td> <td>9045571</td> <td>01.00</td> </tr> <tr> <td>7</td> <td>704511</td> <td>02.00</td> </tr> <tr> <td>6</td> <td>7045</td> <td>01.00</td> </tr> <tr> <td>5</td> <td>3454</td> <td>02.00</td> </tr> <tr> <td>4</td> <td>3454</td> <td>01.00</td> </tr> <tr> <td>3</td> <td>3454</td> <td>02.00</td> </tr> <tr> <td>2</td> <td>417</td> <td>01.00</td> </tr> <tr> <td>1</td> <td>35</td> <td>02.00</td> </tr> </tbody> </table> </div> <div style="margin-top: 10px;"> <p data-bbox="903 1039 1153 1066">(10) Unknown toner Log</p> <table border="0" style="width: 100%; border-collapse: collapse;"> <thead> <tr> <th style="width: 10%;">#</th> <th style="width: 15%;">Count.</th> <th style="width: 75%;">Item</th> </tr> </thead> <tbody> <tr> <td>5</td> <td>3454</td> <td>01.00</td> </tr> <tr> <td>4</td> <td>3454</td> <td>01.00</td> </tr> <tr> <td>3</td> <td>3454</td> <td>01.00</td> </tr> <tr> <td>2</td> <td>417</td> <td>01.00</td> </tr> <tr> <td>1</td> <td>35</td> <td>01.00</td> </tr> </tbody> </table> </div> <div style="margin-top: 10px;"> <p data-bbox="336 1200 512 1227">(11) Counter Log</p> <table border="0" style="width: 100%; border-collapse: collapse;"> <tr> <td style="width: 12.5%;">(f) J04:000</td> <td style="width: 12.5%;">J30:000</td> <td style="width: 12.5%;">J70:000</td> <td style="width: 12.5%;">J91:002</td> <td style="width: 12.5%;">(g) C0030:001</td> <td style="width: 12.5%;">C2101:001</td> <td style="width: 12.5%;">C7000:001</td> <td style="width: 12.5%;">(h) M00:01</td> </tr> <tr> <td>J05:000</td> <td>J31:000</td> <td>J71:000</td> <td>J92:000</td> <td>C0070:001</td> <td>C2102:001</td> <td>C7100:001</td> <td>M00:01</td> </tr> <tr> <td>J10:000</td> <td>J40:000</td> <td>J72:000</td> <td>J93:000</td> <td>C0100:001</td> <td>C2201:001</td> <td>C7101:001</td> <td></td> </tr> <tr> <td>J11:002</td> <td>J41:000</td> <td>J73:000</td> <td>J94:000</td> <td>C0110:001</td> <td>C2202:001</td> <td>C7102:001</td> <td></td> </tr> <tr> <td>J12:000</td> <td>J42:002</td> <td>J74:002</td> <td>J95:000</td> <td>C0150:001</td> <td>C2203:001</td> <td>C7103:001</td> <td></td> </tr> <tr> <td>J13:002</td> <td>J43:002</td> <td>J75:002</td> <td></td> <td></td> <td></td> <td></td> <td></td> </tr> <tr> <td></td> <td></td> <td>J76:000</td> <td></td> <td></td> <td></td> <td></td> <td></td> </tr> </table> </div> <p data-bbox="1078 1413 1326 1440" style="text-align: right;">(6) [XXXXXXXXXXXXXXXXXXXX]</p> </div>	#	Count.	Event Descriptions	#	Count.	Service Code	16	9876543	10.01.08.01.01	8	7881214	01.0060	15	666554	10.01.08.01.02	7	578944	01.0120	14	4988	10.01.08.01.01	6	5296	01.4000	13	4988	10.01.08.01.02	5	5295	01.3100	12	4988		4	2099	01.2000	11	4988		3	1054	01.2000	10	1103		2	809	01.2200	9	1103		1	30	01.2500	8	1103	12.03.08.01.01				7	1103	12.03.08.01.01				6	1027	12.03.08.01.01				5	1027	12.03.0A.01.01				4	1027	12.03.08.01.01				3	1027	12.03.08.01.02				2	550	12.03.0A.01.01				1	28	12.03.08.01.01				#	Count.	Item	8	9045571	01.00	7	704511	02.00	6	7045	01.00	5	3454	02.00	4	3454	01.00	3	3454	02.00	2	417	01.00	1	35	02.00	#	Count.	Item	5	3454	01.00	4	3454	01.00	3	3454	01.00	2	417	01.00	1	35	01.00	(f) J04:000	J30:000	J70:000	J91:002	(g) C0030:001	C2101:001	C7000:001	(h) M00:01	J05:000	J31:000	J71:000	J92:000	C0070:001	C2102:001	C7100:001	M00:01	J10:000	J40:000	J72:000	J93:000	C0100:001	C2201:001	C7101:001		J11:002	J41:000	J73:000	J94:000	C0110:001	C2202:001	C7102:001		J12:000	J42:002	J74:002	J95:000	C0150:001	C2203:001	C7103:001		J13:002	J43:002	J75:002								J76:000					
#	Count.	Event Descriptions	#	Count.	Service Code																																																																																																																																																																																																							
16	9876543	10.01.08.01.01	8	7881214	01.0060																																																																																																																																																																																																							
15	666554	10.01.08.01.02	7	578944	01.0120																																																																																																																																																																																																							
14	4988	10.01.08.01.01	6	5296	01.4000																																																																																																																																																																																																							
13	4988	10.01.08.01.02	5	5295	01.3100																																																																																																																																																																																																							
12	4988		4	2099	01.2000																																																																																																																																																																																																							
11	4988		3	1054	01.2000																																																																																																																																																																																																							
10	1103		2	809	01.2200																																																																																																																																																																																																							
9	1103		1	30	01.2500																																																																																																																																																																																																							
8	1103	12.03.08.01.01																																																																																																																																																																																																										
7	1103	12.03.08.01.01																																																																																																																																																																																																										
6	1027	12.03.08.01.01																																																																																																																																																																																																										
5	1027	12.03.0A.01.01																																																																																																																																																																																																										
4	1027	12.03.08.01.01																																																																																																																																																																																																										
3	1027	12.03.08.01.02																																																																																																																																																																																																										
2	550	12.03.0A.01.01																																																																																																																																																																																																										
1	28	12.03.08.01.01																																																																																																																																																																																																										
#	Count.	Item																																																																																																																																																																																																										
8	9045571	01.00																																																																																																																																																																																																										
7	704511	02.00																																																																																																																																																																																																										
6	7045	01.00																																																																																																																																																																																																										
5	3454	02.00																																																																																																																																																																																																										
4	3454	01.00																																																																																																																																																																																																										
3	3454	02.00																																																																																																																																																																																																										
2	417	01.00																																																																																																																																																																																																										
1	35	02.00																																																																																																																																																																																																										
#	Count.	Item																																																																																																																																																																																																										
5	3454	01.00																																																																																																																																																																																																										
4	3454	01.00																																																																																																																																																																																																										
3	3454	01.00																																																																																																																																																																																																										
2	417	01.00																																																																																																																																																																																																										
1	35	01.00																																																																																																																																																																																																										
(f) J04:000	J30:000	J70:000	J91:002	(g) C0030:001	C2101:001	C7000:001	(h) M00:01																																																																																																																																																																																																					
J05:000	J31:000	J71:000	J92:000	C0070:001	C2102:001	C7100:001	M00:01																																																																																																																																																																																																					
J10:000	J40:000	J72:000	J93:000	C0100:001	C2201:001	C7101:001																																																																																																																																																																																																						
J11:002	J41:000	J73:000	J94:000	C0110:001	C2202:001	C7102:001																																																																																																																																																																																																						
J12:000	J42:002	J74:002	J95:000	C0150:001	C2203:001	C7103:001																																																																																																																																																																																																						
J13:002	J43:002	J75:002																																																																																																																																																																																																										
		J76:000																																																																																																																																																																																																										

Figure 1-3-1

Maintenance item No.	Description			
U000	Detail of event log			
	No.	Items		
(1)		System version		
(2)		System date		
(3)		Engine soft version		
(4)		Engine boot version		
(5)		Operation panel mask version		
(6)		Machine serial number		
(7)	Paper Jam Log	#	Count.	Event
		Remembers 1 to 16 of occurrence. If the occurrence of the previous paper jam is less than 16, all of the paper jams are logged. When the occurrence exceeds 16, the oldest occurrence is removed.	The total page count at the time of the paper jam.	Log code (2 digit, hexadecimal, 5 categories) (a) Cause of a paper jam (b) Paper source (c) Paper size (d) Paper type (e) Paper eject
		(a) Cause of paper jam (Hexadecimal)		
		04: Cover open 05: Secondary paper feed does not start 10: No paper feed from cassette 1 11: No paper feed from cassette 2 12: No paper feed from optional cassette 3 13: No paper feed from optional cassette 4 14: No paper feed from MP tray 18: Misfeed in vertical paper conveying section 19: Misfeed in paper feeder vertical paper conveying section 20: Misfeed in MP tray paper conveying section 21: Multiple sheets in paper feed section 23: Multiple sheets in MP tray conveying section 30: Misfeed in registration/transfer section 40: Misfeed in fuser section (MP tray) 41: Misfeed in fuser section (cassette 1) 42: Misfeed in fuser section (cassette 2) 43: Misfeed in fuser section (optional cassette 3) 44: Misfeed in fuser section (optional cassette 4) 47: Misfeed in fuser section (duplex section) 50: Misfeed in eject section 51: Misfeed in job separator eject section 52: Misfeed in feedshift section 60: Duplex paper conveying section 1 61: Duplex paper conveying section 2 70: No original feed 71: An original jam in the original conveying section 1 72: An original jam in the original conveying section 2 73: An original jam in the original switchback section 74: An original jam in the original switchback/feed section 75: An original jam in the original switchback/conveying section 78: Document processor cover open		

Maintenance item No.	Description																																								
U000																																									
(7) cont.	Paper Jam Log	<table border="1"> <thead> <tr> <th data-bbox="284 309 359 342">No.</th> <th data-bbox="359 309 603 342">Items</th> <th colspan="2" data-bbox="603 309 1441 342">Description</th> </tr> </thead> <tbody> <tr> <td colspan="4" data-bbox="603 342 1441 678"> 80: Finisher timeout jam (built-in finisher) 81: Paper entry sensor nonarrival jam 82: Jam in stapler 83: Exit sensor stay jam 91: Finisher cover open (document finisher) 92: Exit sensor non-arrival jam (document finisher) 93: Reverse sensor jam (document finisher) 94: Paper entry sensor stay/remaining jam (document finisher) 95: Paper conveying sensor jam (document finisher) 96: Jam between the built-in finisher and machine (built-in finisher) </td> </tr> <tr> <td colspan="4" data-bbox="603 678 1441 723">(b) Detail of paper source (Hexadecimal)</td> </tr> <tr> <td colspan="4" data-bbox="603 723 1441 1059"> 00: MP tray 01: Cassette 1 02: Cassette 2 03: Cassette 3 (paper feeder) 04: Cassette 4 (paper feeder) 05: Reserved 06: Reserved 07: Reserved 08: Reserved 09: Reserved </td> </tr> <tr> <td colspan="4" data-bbox="603 1059 1441 1104">(c) Detail of paper size (Hexadecimal)</td> </tr> <tr> <td colspan="4" data-bbox="603 1104 1441 1541"> <table border="1"> <tbody> <tr> <td data-bbox="603 1104 874 1541"> 01: Monarch 02: Business 03: International DL 04: International C5 05: Executive 06: Letter-R 86: Letter-E 07: Legal 08: A4R 88: A4E 09: B5R 89: B5E 0A: A3 0B: B4 </td> <td data-bbox="874 1104 1150 1541"> 0C: Ledger 0D: A5 0E: A6 0F: B6 10: Commercial #9 11: Commercial #6 12: ISO B5 13: Custom size 1E: C4 1F: Postcard 20: Reply-paid postcard 21: Oficio II 22: Special 1 23: Special 2 </td> <td data-bbox="1150 1104 1441 1541"> 24: A3 wide 25: Ledger wide 26: Full bleed paper (12 x 8) 27: 8K 28: 16K-R A8: 16K-E 32: Statement-R B2: Statement-E 33: Folio 34: Western type 2 35: Western type 4 </td> </tr> </tbody> </table> </td> </tr> <tr> <td colspan="4" data-bbox="603 1541 1441 1585">(d) Detail of paper type (Hexadecimal)</td> </tr> <tr> <td colspan="4" data-bbox="603 1585 1441 1883"> <table border="1"> <tbody> <tr> <td data-bbox="603 1585 874 1883"> 01: Plain 02: Transparency 03: Preprinted 04: Labels 05: Bond 06: Recycled 07: Vellum 08: Rough 09: Letterhead </td> <td data-bbox="874 1585 1150 1883"> 0A: Color 0B: Prepunched 0C: Envelope 0D: Cardstock 0E: Coated 0F: 2nd side 10: Media 16 11: High quality </td> <td data-bbox="1150 1585 1441 1883"> 15: Custom 1 16: Custom 2 17: Custom 3 18: Custom 4 19: Custom 5 1A: Custom 6 1B: Custom 7 1C: Custom 8 </td> </tr> </tbody> </table> </td> </tr> </tbody> </table>		No.	Items	Description		80: Finisher timeout jam (built-in finisher) 81: Paper entry sensor nonarrival jam 82: Jam in stapler 83: Exit sensor stay jam 91: Finisher cover open (document finisher) 92: Exit sensor non-arrival jam (document finisher) 93: Reverse sensor jam (document finisher) 94: Paper entry sensor stay/remaining jam (document finisher) 95: Paper conveying sensor jam (document finisher) 96: Jam between the built-in finisher and machine (built-in finisher)				(b) Detail of paper source (Hexadecimal)				00: MP tray 01: Cassette 1 02: Cassette 2 03: Cassette 3 (paper feeder) 04: Cassette 4 (paper feeder) 05: Reserved 06: Reserved 07: Reserved 08: Reserved 09: Reserved				(c) Detail of paper size (Hexadecimal)				<table border="1"> <tbody> <tr> <td data-bbox="603 1104 874 1541"> 01: Monarch 02: Business 03: International DL 04: International C5 05: Executive 06: Letter-R 86: Letter-E 07: Legal 08: A4R 88: A4E 09: B5R 89: B5E 0A: A3 0B: B4 </td> <td data-bbox="874 1104 1150 1541"> 0C: Ledger 0D: A5 0E: A6 0F: B6 10: Commercial #9 11: Commercial #6 12: ISO B5 13: Custom size 1E: C4 1F: Postcard 20: Reply-paid postcard 21: Oficio II 22: Special 1 23: Special 2 </td> <td data-bbox="1150 1104 1441 1541"> 24: A3 wide 25: Ledger wide 26: Full bleed paper (12 x 8) 27: 8K 28: 16K-R A8: 16K-E 32: Statement-R B2: Statement-E 33: Folio 34: Western type 2 35: Western type 4 </td> </tr> </tbody> </table>				01: Monarch 02: Business 03: International DL 04: International C5 05: Executive 06: Letter-R 86: Letter-E 07: Legal 08: A4R 88: A4E 09: B5R 89: B5E 0A: A3 0B: B4	0C: Ledger 0D: A5 0E: A6 0F: B6 10: Commercial #9 11: Commercial #6 12: ISO B5 13: Custom size 1E: C4 1F: Postcard 20: Reply-paid postcard 21: Oficio II 22: Special 1 23: Special 2	24: A3 wide 25: Ledger wide 26: Full bleed paper (12 x 8) 27: 8K 28: 16K-R A8: 16K-E 32: Statement-R B2: Statement-E 33: Folio 34: Western type 2 35: Western type 4	(d) Detail of paper type (Hexadecimal)				<table border="1"> <tbody> <tr> <td data-bbox="603 1585 874 1883"> 01: Plain 02: Transparency 03: Preprinted 04: Labels 05: Bond 06: Recycled 07: Vellum 08: Rough 09: Letterhead </td> <td data-bbox="874 1585 1150 1883"> 0A: Color 0B: Prepunched 0C: Envelope 0D: Cardstock 0E: Coated 0F: 2nd side 10: Media 16 11: High quality </td> <td data-bbox="1150 1585 1441 1883"> 15: Custom 1 16: Custom 2 17: Custom 3 18: Custom 4 19: Custom 5 1A: Custom 6 1B: Custom 7 1C: Custom 8 </td> </tr> </tbody> </table>				01: Plain 02: Transparency 03: Preprinted 04: Labels 05: Bond 06: Recycled 07: Vellum 08: Rough 09: Letterhead	0A: Color 0B: Prepunched 0C: Envelope 0D: Cardstock 0E: Coated 0F: 2nd side 10: Media 16 11: High quality	15: Custom 1 16: Custom 2 17: Custom 3 18: Custom 4 19: Custom 5 1A: Custom 6 1B: Custom 7 1C: Custom 8
No.	Items	Description																																							
80: Finisher timeout jam (built-in finisher) 81: Paper entry sensor nonarrival jam 82: Jam in stapler 83: Exit sensor stay jam 91: Finisher cover open (document finisher) 92: Exit sensor non-arrival jam (document finisher) 93: Reverse sensor jam (document finisher) 94: Paper entry sensor stay/remaining jam (document finisher) 95: Paper conveying sensor jam (document finisher) 96: Jam between the built-in finisher and machine (built-in finisher)																																									
(b) Detail of paper source (Hexadecimal)																																									
00: MP tray 01: Cassette 1 02: Cassette 2 03: Cassette 3 (paper feeder) 04: Cassette 4 (paper feeder) 05: Reserved 06: Reserved 07: Reserved 08: Reserved 09: Reserved																																									
(c) Detail of paper size (Hexadecimal)																																									
<table border="1"> <tbody> <tr> <td data-bbox="603 1104 874 1541"> 01: Monarch 02: Business 03: International DL 04: International C5 05: Executive 06: Letter-R 86: Letter-E 07: Legal 08: A4R 88: A4E 09: B5R 89: B5E 0A: A3 0B: B4 </td> <td data-bbox="874 1104 1150 1541"> 0C: Ledger 0D: A5 0E: A6 0F: B6 10: Commercial #9 11: Commercial #6 12: ISO B5 13: Custom size 1E: C4 1F: Postcard 20: Reply-paid postcard 21: Oficio II 22: Special 1 23: Special 2 </td> <td data-bbox="1150 1104 1441 1541"> 24: A3 wide 25: Ledger wide 26: Full bleed paper (12 x 8) 27: 8K 28: 16K-R A8: 16K-E 32: Statement-R B2: Statement-E 33: Folio 34: Western type 2 35: Western type 4 </td> </tr> </tbody> </table>				01: Monarch 02: Business 03: International DL 04: International C5 05: Executive 06: Letter-R 86: Letter-E 07: Legal 08: A4R 88: A4E 09: B5R 89: B5E 0A: A3 0B: B4	0C: Ledger 0D: A5 0E: A6 0F: B6 10: Commercial #9 11: Commercial #6 12: ISO B5 13: Custom size 1E: C4 1F: Postcard 20: Reply-paid postcard 21: Oficio II 22: Special 1 23: Special 2	24: A3 wide 25: Ledger wide 26: Full bleed paper (12 x 8) 27: 8K 28: 16K-R A8: 16K-E 32: Statement-R B2: Statement-E 33: Folio 34: Western type 2 35: Western type 4																																			
01: Monarch 02: Business 03: International DL 04: International C5 05: Executive 06: Letter-R 86: Letter-E 07: Legal 08: A4R 88: A4E 09: B5R 89: B5E 0A: A3 0B: B4	0C: Ledger 0D: A5 0E: A6 0F: B6 10: Commercial #9 11: Commercial #6 12: ISO B5 13: Custom size 1E: C4 1F: Postcard 20: Reply-paid postcard 21: Oficio II 22: Special 1 23: Special 2	24: A3 wide 25: Ledger wide 26: Full bleed paper (12 x 8) 27: 8K 28: 16K-R A8: 16K-E 32: Statement-R B2: Statement-E 33: Folio 34: Western type 2 35: Western type 4																																							
(d) Detail of paper type (Hexadecimal)																																									
<table border="1"> <tbody> <tr> <td data-bbox="603 1585 874 1883"> 01: Plain 02: Transparency 03: Preprinted 04: Labels 05: Bond 06: Recycled 07: Vellum 08: Rough 09: Letterhead </td> <td data-bbox="874 1585 1150 1883"> 0A: Color 0B: Prepunched 0C: Envelope 0D: Cardstock 0E: Coated 0F: 2nd side 10: Media 16 11: High quality </td> <td data-bbox="1150 1585 1441 1883"> 15: Custom 1 16: Custom 2 17: Custom 3 18: Custom 4 19: Custom 5 1A: Custom 6 1B: Custom 7 1C: Custom 8 </td> </tr> </tbody> </table>				01: Plain 02: Transparency 03: Preprinted 04: Labels 05: Bond 06: Recycled 07: Vellum 08: Rough 09: Letterhead	0A: Color 0B: Prepunched 0C: Envelope 0D: Cardstock 0E: Coated 0F: 2nd side 10: Media 16 11: High quality	15: Custom 1 16: Custom 2 17: Custom 3 18: Custom 4 19: Custom 5 1A: Custom 6 1B: Custom 7 1C: Custom 8																																			
01: Plain 02: Transparency 03: Preprinted 04: Labels 05: Bond 06: Recycled 07: Vellum 08: Rough 09: Letterhead	0A: Color 0B: Prepunched 0C: Envelope 0D: Cardstock 0E: Coated 0F: 2nd side 10: Media 16 11: High quality	15: Custom 1 16: Custom 2 17: Custom 3 18: Custom 4 19: Custom 5 1A: Custom 6 1B: Custom 7 1C: Custom 8																																							

Maintenance item No.	Description				
U000	Description				
	(7) cont.	Paper Jam Log	(e) Detail of paper exit location (Hexadecimal) 01: Face down (FD) 02: Face up (FU)/ Document finisher face up (FU)/ 3000-sheet document finisher left sub tray (FU) 03: Document finisher face down (FD) 04 to 48: Reserved		
	(8)	Service Call Log	#	Count.	Service Code
			Remembers 1 to 8 of occurrence of self diagnostics error. If the occurrence of the previous diagnostics error is less than 8, all of the diagnostics errors are logged.	The total page count at the time of the self diagnostics error.	Self diagnostic error code (See page 1-4-20) Example: 01.6000 01: Self diagnostic error 6000: Self diagnostic error code number
	(9)	Maintenance Log	#	Count.	Item
		Remembers 1 to 8 of occurrence of replacement. If the occurrence of the previous replacement of toner container is less than 8, all of the occurrences of replacement are logged.	The total page count at the time of the replacement of the toner container.	Code of maintenance replacing item (1 byte, 2 categories) First byte (Replacing item) 01: Toner container 02: Maintenance kit Second byte (Type of replacing item) 00: Fixed	
(10)	Unknown Toner Log	#	Count.	Item	
		Remembers 1 to 5 of occurrence of unknown toner detection. If the occurrence of the previous unknown toner detection is less than 5, all of the unknown toner detection are logged.	The total page count at the time of the [Toner Empty] error with using an unknown toner container.	Unknown toner log code (1 byte, 2 categories) First byte 01: Fixed (Toner container) Second byte 00: Fixed (Black)	

Maintenance item No.	Description								
U000	<table border="1"> <thead> <tr> <th data-bbox="284 309 359 347">No.</th> <th data-bbox="359 309 603 347">Items</th> <th colspan="3" data-bbox="603 309 1423 347">Description</th> </tr> </thead> </table>				No.	Items	Description		
	No.	Items	Description						
(11)	<p>Counter Log</p> <p>Comprised of three log counters including paper jams, self diagnostics errors, and replacement of the toner container.</p>	<p>(f) Paper jam</p> <p>Indicates the log counter of paper jams depending on location.</p> <p>Refer to Paper Jam Log.</p> <p>All instances including those are not occurred are displayed.</p>	<p>(g) Self diagnostic error</p> <p>Indicates the log counter of self diagnostics errors depending on cause. (See page 1-4-20)</p> <p>Example: C6000: 4</p> <p>Self diagnostics error 6000 has happened four times.</p>	<p>(h) Maintenance item replacing</p> <p>Indicates the log counter depending on the maintenance item for maintenance.</p> <p>T: Toner container 00: Black M: Maintenance kit 00: MK-671</p> <p>Example: T00: 1 The toner container has been replaced once.</p>					

Maintenance item No.	Description																																																																																																																																				
U000	<p>Service status page (1)</p> <div style="border: 1px solid black; padding: 10px; margin: 10px auto; width: 80%;"> <p>Service Status Page MFP</p> <p style="text-align: right;">(2) 09/08/2009 12:00</p> <p>(1) Firmware version 2K5_2000.000.000 2009.08.09 (3) [XXXXXXXX] (4) [XXXXXXXX] (5) [XXXXXXXX]</p> <hr/> <p>Controller Information</p> <table style="width: 100%; border-collapse: collapse;"> <tr> <td colspan="2">Memory status</td> <td colspan="2">(27) FRPO Status</td> </tr> <tr> <td>(6) Total Size</td> <td>1.0 GB</td> <td>Default Pattern Switch</td> <td>B8 0</td> </tr> <tr> <td></td> <td></td> <td>Default Font Number</td> <td>C5*10000+C2*100+C3 00000</td> </tr> <tr> <td colspan="2">Time</td> <td></td> <td>.</td> </tr> <tr> <td>(7) Local Time Zone</td> <td>+01:00 Tokio</td> <td></td> <td>.</td> </tr> <tr> <td>(8) Date and Time</td> <td>17/06/2009 08:40</td> <td></td> <td>.</td> </tr> <tr> <td>(9) Time Server</td> <td>10.183.53.13</td> <td></td> <td>.</td> </tr> <tr> <td></td> <td></td> <td></td> <td>.</td> </tr> <tr> <td colspan="2">Installed Options</td> <td></td> <td>.</td> </tr> <tr> <td>(10) Document Processor</td> <td>Installed</td> <td></td> <td>.</td> </tr> <tr> <td>(11) Paper feeder</td> <td>Cassette</td> <td></td> <td>.</td> </tr> <tr> <td>(12) Finisher</td> <td>1000-Finisher</td> <td></td> <td>.</td> </tr> <tr> <td>(13) Job Sparator</td> <td>Installed</td> <td></td> <td>.</td> </tr> <tr> <td>(14) Security Kit</td> <td>Not Installed</td> <td></td> <td>.</td> </tr> <tr> <td></td> <td>Data Security Kit (E) Software Type II</td> <td></td> <td>.</td> </tr> <tr> <td colspan="2">Digital Dot Coverage</td> <td></td> <td>.</td> </tr> <tr> <td>(15) Average(%) / Usage Page(A4/Letter Conversion)</td> <td></td> <td></td> <td>.</td> </tr> <tr> <td>(16) Total</td> <td></td> <td></td> <td>.</td> </tr> <tr> <td> K: 1.10</td> <td>/ 1111111.11</td> <td></td> <td>.</td> </tr> <tr> <td>(17) Copy</td> <td></td> <td></td> <td>.</td> </tr> <tr> <td> K: 1.10</td> <td>/ 1111111.11</td> <td></td> <td>.</td> </tr> <tr> <td>(18) Printer</td> <td></td> <td></td> <td>.</td> </tr> <tr> <td> K: 1.10</td> <td>/ 1111111.11</td> <td></td> <td>.</td> </tr> <tr> <td>(19) FAX</td> <td></td> <td></td> <td>.</td> </tr> <tr> <td> K: 1.10</td> <td>/ 1111111.11</td> <td></td> <td>.</td> </tr> <tr> <td>(20) Period</td> <td>(03/11/2009 - 27/10/2009 08:40)</td> <td></td> <td>.</td> </tr> <tr> <td>(21) Last Page (%)</td> <td>1.00</td> <td></td> <td>.</td> </tr> <tr> <td></td> <td></td> <td></td> <td>.</td> </tr> <tr> <td>(22) FAX Information Slot1/Slot2</td> <td></td> <td></td> <td>.</td> </tr> <tr> <td>(23) Rings (Normal)</td> <td>3</td> <td></td> <td>.</td> </tr> <tr> <td>(24) Rings (FAX/TEL)</td> <td>3</td> <td></td> <td>.</td> </tr> <tr> <td>(25) Rings (TAD)</td> <td>3</td> <td></td> <td>.</td> </tr> <tr> <td>(26) Option DIMM Size</td> <td>16 MB</td> <td>e-MPS error control</td> <td>Y6 0</td> </tr> </table> </div> <hr style="margin-top: 20px;"/> <p style="text-align: center;">1 (28) [XXXXXXXXXXXXXXXXXXXX]</p>	Memory status		(27) FRPO Status		(6) Total Size	1.0 GB	Default Pattern Switch	B8 0			Default Font Number	C5*10000+C2*100+C3 00000	Time			.	(7) Local Time Zone	+01:00 Tokio		.	(8) Date and Time	17/06/2009 08:40		.	(9) Time Server	10.183.53.13		.				.	Installed Options			.	(10) Document Processor	Installed		.	(11) Paper feeder	Cassette		.	(12) Finisher	1000-Finisher		.	(13) Job Sparator	Installed		.	(14) Security Kit	Not Installed		.		Data Security Kit (E) Software Type II		.	Digital Dot Coverage			.	(15) Average(%) / Usage Page(A4/Letter Conversion)			.	(16) Total			.	K: 1.10	/ 1111111.11		.	(17) Copy			.	K: 1.10	/ 1111111.11		.	(18) Printer			.	K: 1.10	/ 1111111.11		.	(19) FAX			.	K: 1.10	/ 1111111.11		.	(20) Period	(03/11/2009 - 27/10/2009 08:40)		.	(21) Last Page (%)	1.00		.				.	(22) FAX Information Slot1/Slot2			.	(23) Rings (Normal)	3		.	(24) Rings (FAX/TEL)	3		.	(25) Rings (TAD)	3		.	(26) Option DIMM Size	16 MB	e-MPS error control	Y6 0
Memory status		(27) FRPO Status																																																																																																																																			
(6) Total Size	1.0 GB	Default Pattern Switch	B8 0																																																																																																																																		
		Default Font Number	C5*10000+C2*100+C3 00000																																																																																																																																		
Time			.																																																																																																																																		
(7) Local Time Zone	+01:00 Tokio		.																																																																																																																																		
(8) Date and Time	17/06/2009 08:40		.																																																																																																																																		
(9) Time Server	10.183.53.13		.																																																																																																																																		
			.																																																																																																																																		
Installed Options			.																																																																																																																																		
(10) Document Processor	Installed		.																																																																																																																																		
(11) Paper feeder	Cassette		.																																																																																																																																		
(12) Finisher	1000-Finisher		.																																																																																																																																		
(13) Job Sparator	Installed		.																																																																																																																																		
(14) Security Kit	Not Installed		.																																																																																																																																		
	Data Security Kit (E) Software Type II		.																																																																																																																																		
Digital Dot Coverage			.																																																																																																																																		
(15) Average(%) / Usage Page(A4/Letter Conversion)			.																																																																																																																																		
(16) Total			.																																																																																																																																		
K: 1.10	/ 1111111.11		.																																																																																																																																		
(17) Copy			.																																																																																																																																		
K: 1.10	/ 1111111.11		.																																																																																																																																		
(18) Printer			.																																																																																																																																		
K: 1.10	/ 1111111.11		.																																																																																																																																		
(19) FAX			.																																																																																																																																		
K: 1.10	/ 1111111.11		.																																																																																																																																		
(20) Period	(03/11/2009 - 27/10/2009 08:40)		.																																																																																																																																		
(21) Last Page (%)	1.00		.																																																																																																																																		
			.																																																																																																																																		
(22) FAX Information Slot1/Slot2			.																																																																																																																																		
(23) Rings (Normal)	3		.																																																																																																																																		
(24) Rings (FAX/TEL)	3		.																																																																																																																																		
(25) Rings (TAD)	3		.																																																																																																																																		
(26) Option DIMM Size	16 MB	e-MPS error control	Y6 0																																																																																																																																		

Figure 1-3-2

Maintenance item No.	Description																																																																																								
U000	Detail of service status page																																																																																								
	<table border="1"> <thead> <tr> <th data-bbox="292 333 365 376">No.</th> <th data-bbox="365 333 807 376">Description</th> <th data-bbox="807 333 1417 376">Supplement</th> </tr> </thead> <tbody> <tr> <td>(1)</td> <td>System version</td> <td></td> </tr> <tr> <td>(2)</td> <td>System date</td> <td></td> </tr> <tr> <td>(3)</td> <td>Engine soft version</td> <td></td> </tr> <tr> <td>(4)</td> <td>Engine boot version</td> <td></td> </tr> <tr> <td>(5)</td> <td>Operation panel mask version</td> <td></td> </tr> <tr> <td>(6)</td> <td>Total RAM size</td> <td></td> </tr> <tr> <td>(7)</td> <td>Local time zone</td> <td></td> </tr> <tr> <td>(8)</td> <td>Report output date</td> <td>Day/Month/Year hour:minute</td> </tr> <tr> <td>(9)</td> <td>NTP server name</td> <td></td> </tr> <tr> <td>(10)</td> <td>Presence or absence of the optional DP</td> <td>Installed/Not Installed</td> </tr> <tr> <td>(11)</td> <td>Presence or absence of the optional paper feeder</td> <td>Cassette/LCF/Not Installed</td> </tr> <tr> <td>(12)</td> <td>Presence or absence of the optional document finisher</td> <td>Inner Finisher Tray/3000-Finisher/1000-Finisher/Not Installed</td> </tr> <tr> <td>(13)</td> <td>Presence or absence of the optional job separator</td> <td>Installed/Not Installed</td> </tr> <tr> <td>(14)</td> <td>Presence or absence of the optional data security kit</td> <td>Installed/Not Installed</td> </tr> <tr> <td>(15)</td> <td>Page of relation to the A4/Letter</td> <td></td> </tr> <tr> <td>(16)</td> <td>Average coverage for total</td> <td></td> </tr> <tr> <td>(17)</td> <td>Average coverage for copy</td> <td></td> </tr> <tr> <td>(18)</td> <td>Average coverage for printer</td> <td></td> </tr> <tr> <td>(19)</td> <td>Average coverage for fax</td> <td></td> </tr> <tr> <td>(20)</td> <td>Cleared date and output date</td> <td></td> </tr> <tr> <td>(21)</td> <td>Coverage on the final output page</td> <td></td> </tr> <tr> <td>(22)</td> <td>Fax kit information</td> <td>This item is printed only when the fax kit is installed.</td> </tr> <tr> <td>(23)</td> <td>Number of rings</td> <td>0 to 15</td> </tr> <tr> <td>(24)</td> <td>Number of rings before automatic switching</td> <td>0 to 15</td> </tr> <tr> <td>(25)</td> <td>Number of rings before connecting to answering machine</td> <td>0 to 15</td> </tr> <tr> <td>(26)</td> <td>Optional DIMM size</td> <td></td> </tr> <tr> <td>(27)</td> <td>FRPO setting</td> <td></td> </tr> <tr> <td>(28)</td> <td>Machine serial number</td> <td></td> </tr> </tbody> </table>	No.	Description	Supplement	(1)	System version		(2)	System date		(3)	Engine soft version		(4)	Engine boot version		(5)	Operation panel mask version		(6)	Total RAM size		(7)	Local time zone		(8)	Report output date	Day/Month/Year hour:minute	(9)	NTP server name		(10)	Presence or absence of the optional DP	Installed/Not Installed	(11)	Presence or absence of the optional paper feeder	Cassette/LCF/Not Installed	(12)	Presence or absence of the optional document finisher	Inner Finisher Tray/3000-Finisher/1000-Finisher/Not Installed	(13)	Presence or absence of the optional job separator	Installed/Not Installed	(14)	Presence or absence of the optional data security kit	Installed/Not Installed	(15)	Page of relation to the A4/Letter		(16)	Average coverage for total		(17)	Average coverage for copy		(18)	Average coverage for printer		(19)	Average coverage for fax		(20)	Cleared date and output date		(21)	Coverage on the final output page		(22)	Fax kit information	This item is printed only when the fax kit is installed.	(23)	Number of rings	0 to 15	(24)	Number of rings before automatic switching	0 to 15	(25)	Number of rings before connecting to answering machine	0 to 15	(26)	Optional DIMM size		(27)	FRPO setting		(28)	Machine serial number		
No.	Description	Supplement																																																																																							
(1)	System version																																																																																								
(2)	System date																																																																																								
(3)	Engine soft version																																																																																								
(4)	Engine boot version																																																																																								
(5)	Operation panel mask version																																																																																								
(6)	Total RAM size																																																																																								
(7)	Local time zone																																																																																								
(8)	Report output date	Day/Month/Year hour:minute																																																																																							
(9)	NTP server name																																																																																								
(10)	Presence or absence of the optional DP	Installed/Not Installed																																																																																							
(11)	Presence or absence of the optional paper feeder	Cassette/LCF/Not Installed																																																																																							
(12)	Presence or absence of the optional document finisher	Inner Finisher Tray/3000-Finisher/1000-Finisher/Not Installed																																																																																							
(13)	Presence or absence of the optional job separator	Installed/Not Installed																																																																																							
(14)	Presence or absence of the optional data security kit	Installed/Not Installed																																																																																							
(15)	Page of relation to the A4/Letter																																																																																								
(16)	Average coverage for total																																																																																								
(17)	Average coverage for copy																																																																																								
(18)	Average coverage for printer																																																																																								
(19)	Average coverage for fax																																																																																								
(20)	Cleared date and output date																																																																																								
(21)	Coverage on the final output page																																																																																								
(22)	Fax kit information	This item is printed only when the fax kit is installed.																																																																																							
(23)	Number of rings	0 to 15																																																																																							
(24)	Number of rings before automatic switching	0 to 15																																																																																							
(25)	Number of rings before connecting to answering machine	0 to 15																																																																																							
(26)	Optional DIMM size																																																																																								
(27)	FRPO setting																																																																																								
(28)	Machine serial number																																																																																								

Maintenance item No.	Description		
U000	No.	Description	Supplement
	(29)	NV RAM version	_ Bb 04B29 _ Bb 04B29 (a) (b) (c) (d) (e) (f) (a) Consistency of the present software version and the database _ (underscore): OK * (Asterisk): NG (b) Database version (c) The oldest time stamp of database version (d) Consistency of the present software version and the ME firmware version _ (underscore): OK * (Asterisk): NG (e) ME firmware version (f) The oldest time stamp of the ME database version Normal if (a) and (d) are underscored, and (b) and (e) are identical with (c) and (f).
	(30)	Scanner firmware version	
	(31)	Fax firmware version	This item is printed only when the fax kit is installed.
	(32)	Mac address	
	(33)	Send date	
	(34)	Send address	
	(35)	Destination information/Area information	
	(36)	Margin settings	Top margin/Left margin
	(37)	Margin/Page length/Page width settings	Top margin integer part/Top margin decimal part/ Left margin integer part/Left margin decimal part/ Page length integer part/Page length decimal part/ Page width integer part/Page width decimal part
	(38)	Life counter (The first line)	Machine life counter/MP tray counter/ Cassette 1 counter/Cassette 2 counter/ Cassette 3 counter/Cassette 4 counter/Duplex counter
		Life counter (The second line)	Drum unit counter/Developing unit counter/ Maintenance kit counter/
	(39)	Panel lock information	0: OFF/1: Partial lock/2: Full lock
	(40)	USB information	0: Not installed/1: Full speed/2: Hi speed
	(41)	Paper handling information	0: Paper source unit select/1: Paper source unit
	(42)	Black and white printing double count mode	0: All single counts/1: A3, Single count, Less than 420 mm/2: Legal, Single count, 356 mm or less/3: Folio, Single count, Less the 330 mm
	(43)	Billing counting timing	
	(44)	Temperature (machine inside)	
	(45)	Temperature (machine outside)	
	(46)	Relative temperature (machine outside)	
(47)	Absolute temperature (machine outside)		

Maintenance item No.	Description		
U000	No.	Description	Supplement
	(48)	Fixed assets number	
	(49)	Job complete judgment timeout time setting for local interface	
	(50)	Media type attributes 1 to 28 (Not used: 18, 19, 20)	Weight settings 0: Light / 1: Normal 1 / 2: Normal 2 / 3: Normal 3 / 4: Heavy 1 / 5: Heavy 2 / 6: Heavy 3 / 7: Extra Heavy Fuser settings 0: High / 1: Middle / 2: Low / 3: Vellum Duplex settings 0: Disable / 1: Enable
	(51)	RFID information	
	(52)	RFID reader/writer version information	
	(53)	Maintenance information	
	(54)	Drum serial number	Black/Cyan/Magenta/Yellow
<p>Completion Press the stop key. The screen for selecting a maintenance item No. is displayed.</p>			
U001	<p>Exiting the maintenance mode Description Exits the maintenance mode and returns to the normal copy mode. Purpose To exit the maintenance mode. Method Press the start key. The normal copy mode is entered.</p>		
U002	<p>Setting the factory default data Description Restores the machine conditions to the factory default settings. Purpose To move the mirror frame of the scanner to the position for transport (position in which the frame can be fixed). Method</p> <ol style="list-style-type: none"> 1. Press the start key. 2. Press [MODE1(ALL)] on the touch panel. 3. Press the start key. The mirror frame of the scanner returns to the position for transport. 4. Turn the main power switch off and on. <p>An error code is displayed in case of an initialization error. Refer to the table of the error codes on P.1-3-19. When ERROR 09 occurred, turn main power switch off then on, format the hard disk using maintenance item U024, and execute initialization using maintenance item U002. For other errors occurred, turn main power switch off then on, and execute initialization using maintenance item U002.</p>		

Maintenance item No.	Description										
<p>U003</p>	<p>Setting the service telephone number</p> <p>Description Sets the telephone number to be displayed when a service call code is detected.</p> <p>Purpose To set the telephone number to call service when installing the machine.</p> <p>Method Press the start key. The currently set telephone number is displayed.</p> <p>Setting</p> <ol style="list-style-type: none"> 1. Press the start key. The keys to enter the number are displayed on the touch panel. 2. Enter a telephone number (up to 15 digits). 3. Press the start key. The setting is set. <p>Completion Press the stop key. The screen for selecting a maintenance item No. is displayed.</p>										
<p>U004</p>	<p>Displaying the machine number</p> <p>Description Sets or displays the machine number.</p> <p>Purpose To check or set the machine number.</p> <p>Method</p> <ol style="list-style-type: none"> 1. Press the start key. If the machine serial number of engine PWB matches with that of main PWB <table border="1" data-bbox="333 1014 1398 1097"> <thead> <tr> <th>Display</th> <th>Operation</th> </tr> </thead> <tbody> <tr> <td>MACHINE No.</td> <td>Displays the machine serial number</td> </tr> </tbody> </table> <p>If the machine serial number of engine PWB does not match with that of main PWB</p> <table border="1" data-bbox="333 1149 1398 1272"> <thead> <tr> <th>Display</th> <th>Operation</th> </tr> </thead> <tbody> <tr> <td>MACHINE No. (MAIN)</td> <td>Displays the machine serial number of main</td> </tr> <tr> <td>MACHINE No. (ENGINE)</td> <td>Displays the machine serial number of engine</td> </tr> </tbody> </table> <p>Setting Carry out if the machine serial number does not match.</p> <ol style="list-style-type: none"> 1. Press [EXECUTE]. 2. Press the start key. Writing of serial No. starts. <p>Completion Press the stop key. The screen for selecting a maintenance item No. is displayed.</p>	Display	Operation	MACHINE No.	Displays the machine serial number	Display	Operation	MACHINE No. (MAIN)	Displays the machine serial number of main	MACHINE No. (ENGINE)	Displays the machine serial number of engine
Display	Operation										
MACHINE No.	Displays the machine serial number										
Display	Operation										
MACHINE No. (MAIN)	Displays the machine serial number of main										
MACHINE No. (ENGINE)	Displays the machine serial number of engine										

Maintenance item No.	Description																																												
U019	<p>Displaying the ROM version</p> <p>Description Displays the part number of the ROM fitted to each PWB.</p> <p>Purpose To check the part number or to decide, if the newest version of ROM is installed.</p> <p>Method</p> <ol style="list-style-type: none"> 1. Press the start key. The ROM version are displayed. 2. Change the screen using the cursor up/down keys. <table border="1" data-bbox="333 539 1398 1453"> <thead> <tr> <th data-bbox="341 546 636 584">Display</th> <th data-bbox="636 546 1398 584">Description</th> </tr> </thead> <tbody> <tr> <td data-bbox="341 584 636 622">MAIN</td> <td data-bbox="636 584 1398 622">Main ROM</td> </tr> <tr> <td data-bbox="341 622 636 660">MMI</td> <td data-bbox="636 622 1398 660">Operation ROM</td> </tr> <tr> <td data-bbox="341 660 636 698">ENGINE</td> <td data-bbox="636 660 1398 698">Engine ROM</td> </tr> <tr> <td data-bbox="341 698 636 736">ENGINE BOOT</td> <td data-bbox="636 698 1398 736">Engine booting</td> </tr> <tr> <td data-bbox="341 736 636 775">ENGINE POWER</td> <td data-bbox="636 736 1398 775">Engine power</td> </tr> <tr> <td data-bbox="341 775 636 813">SCANNER</td> <td data-bbox="636 775 1398 813">Scanner ROM</td> </tr> <tr> <td data-bbox="341 813 636 851">BROWSER</td> <td data-bbox="636 813 1398 851">Browser ROM</td> </tr> <tr> <td data-bbox="341 851 636 889">OPTION LANGUAGE</td> <td data-bbox="636 851 1398 889">Optional language ROM</td> </tr> <tr> <td data-bbox="341 889 636 927">DICTIONARY</td> <td data-bbox="636 889 1398 927">-</td> </tr> <tr> <td data-bbox="341 927 636 965">DBA</td> <td data-bbox="636 927 1398 965">Database connection</td> </tr> <tr> <td data-bbox="341 965 636 1003">Solution Framework</td> <td data-bbox="636 965 1398 1003">Solution framework</td> </tr> <tr> <td data-bbox="341 1003 636 1041">DP</td> <td data-bbox="636 1003 1398 1041">Optional DP ROM</td> </tr> <tr> <td data-bbox="341 1041 636 1079">500x2PF</td> <td data-bbox="636 1041 1398 1079">Optional paper feeder ROM</td> </tr> <tr> <td data-bbox="341 1079 636 1117">1000DF</td> <td data-bbox="636 1079 1398 1117">Optional document finisher ROM</td> </tr> <tr> <td data-bbox="341 1117 636 1155">INNER DF</td> <td data-bbox="636 1117 1398 1155">Optional built-in finisher ROM</td> </tr> <tr> <td data-bbox="341 1155 636 1193">FAX BOOT1</td> <td data-bbox="636 1155 1398 1193">Optional fax control PWB booting (port 1)</td> </tr> <tr> <td data-bbox="341 1193 636 1232">FAX APL1</td> <td data-bbox="636 1193 1398 1232">Optional fax control PWB APL (port 1)</td> </tr> <tr> <td data-bbox="341 1232 636 1270">FAX IPL1</td> <td data-bbox="636 1232 1398 1270">Optional fax control PWB IPL (port 1)</td> </tr> <tr> <td data-bbox="341 1270 636 1308">FAX BOOT2</td> <td data-bbox="636 1270 1398 1308">Fax control PWB booting (port 2: optional dual FAX)</td> </tr> <tr> <td data-bbox="341 1308 636 1346">FAX APL2</td> <td data-bbox="636 1308 1398 1346">Fax control PWB APL (port 2: optional dual FAX)</td> </tr> <tr> <td data-bbox="341 1346 636 1384">FAX IPL2</td> <td data-bbox="636 1346 1398 1384">Fax control PWB IPL (port 2: optional dual FAX)</td> </tr> </tbody> </table> <p>Completion Press the stop key. The screen for selecting a maintenance item No. is displayed.</p>	Display	Description	MAIN	Main ROM	MMI	Operation ROM	ENGINE	Engine ROM	ENGINE BOOT	Engine booting	ENGINE POWER	Engine power	SCANNER	Scanner ROM	BROWSER	Browser ROM	OPTION LANGUAGE	Optional language ROM	DICTIONARY	-	DBA	Database connection	Solution Framework	Solution framework	DP	Optional DP ROM	500x2PF	Optional paper feeder ROM	1000DF	Optional document finisher ROM	INNER DF	Optional built-in finisher ROM	FAX BOOT1	Optional fax control PWB booting (port 1)	FAX APL1	Optional fax control PWB APL (port 1)	FAX IPL1	Optional fax control PWB IPL (port 1)	FAX BOOT2	Fax control PWB booting (port 2: optional dual FAX)	FAX APL2	Fax control PWB APL (port 2: optional dual FAX)	FAX IPL2	Fax control PWB IPL (port 2: optional dual FAX)
Display	Description																																												
MAIN	Main ROM																																												
MMI	Operation ROM																																												
ENGINE	Engine ROM																																												
ENGINE BOOT	Engine booting																																												
ENGINE POWER	Engine power																																												
SCANNER	Scanner ROM																																												
BROWSER	Browser ROM																																												
OPTION LANGUAGE	Optional language ROM																																												
DICTIONARY	-																																												
DBA	Database connection																																												
Solution Framework	Solution framework																																												
DP	Optional DP ROM																																												
500x2PF	Optional paper feeder ROM																																												
1000DF	Optional document finisher ROM																																												
INNER DF	Optional built-in finisher ROM																																												
FAX BOOT1	Optional fax control PWB booting (port 1)																																												
FAX APL1	Optional fax control PWB APL (port 1)																																												
FAX IPL1	Optional fax control PWB IPL (port 1)																																												
FAX BOOT2	Fax control PWB booting (port 2: optional dual FAX)																																												
FAX APL2	Fax control PWB APL (port 2: optional dual FAX)																																												
FAX IPL2	Fax control PWB IPL (port 2: optional dual FAX)																																												

Maintenance item No.	Description																												
U021	<p>Initializing counters and mode settings</p> <p>Description Initializes all settings, except those pertinent to the type of machine, namely each counter, service call history and mode setting. Also initializes backup RAM according to region specification selected in maintenance item U252 Setting the destination. Refer to *1 of the maintenance mode item list about the item initialized.</p> <p>Purpose To return the machine settings to their factory default.</p> <p>Method</p> <ol style="list-style-type: none"> 1. Press the start key. 2. Press [EXECUTE] on the touch panel. 3. Press the start key. All data other than that for adjustments due to variations between machines is initialized based on the destination setting. 4. Turn the main power switch off and on. <p>An error code is displayed in case of an initialization error. When ERROR 09 occurred, turn main power switch off then on, format the hard disk using maintenance item U024, and execute initialization using maintenance item U021. For other errors occurred, turn main power switch off then on, and execute initialization using maintenance item U021.</p> <p>Error codes</p> <table border="1" data-bbox="333 913 1396 1496"> <thead> <tr> <th>Codes</th> <th>Description</th> </tr> </thead> <tbody> <tr> <td>ERROR 01</td> <td>Configuration initialization error</td> </tr> <tr> <td>ERROR 02</td> <td>Counter initialization error</td> </tr> <tr> <td>ERROR 03</td> <td>One-touch initialization error</td> </tr> <tr> <td>ERROR 04</td> <td>Panel program initialization error</td> </tr> <tr> <td>ERROR 05</td> <td>Event log initialization error</td> </tr> <tr> <td>ERROR 06</td> <td>Account initialization error</td> </tr> <tr> <td>ERROR 07</td> <td>Address book initialization error</td> </tr> <tr> <td>ERROR 08</td> <td>Department initialization error</td> </tr> <tr> <td>ERROR 09</td> <td>Document box initialization error</td> </tr> <tr> <td>ERROR 0a</td> <td>Permissibility initialization error</td> </tr> <tr> <td>ERROR 0b</td> <td>Job log initialization error</td> </tr> <tr> <td>ERROR 20</td> <td>Engine initialization error</td> </tr> <tr> <td>ERROR 40</td> <td>Scanner initialization error</td> </tr> </tbody> </table>	Codes	Description	ERROR 01	Configuration initialization error	ERROR 02	Counter initialization error	ERROR 03	One-touch initialization error	ERROR 04	Panel program initialization error	ERROR 05	Event log initialization error	ERROR 06	Account initialization error	ERROR 07	Address book initialization error	ERROR 08	Department initialization error	ERROR 09	Document box initialization error	ERROR 0a	Permissibility initialization error	ERROR 0b	Job log initialization error	ERROR 20	Engine initialization error	ERROR 40	Scanner initialization error
Codes	Description																												
ERROR 01	Configuration initialization error																												
ERROR 02	Counter initialization error																												
ERROR 03	One-touch initialization error																												
ERROR 04	Panel program initialization error																												
ERROR 05	Event log initialization error																												
ERROR 06	Account initialization error																												
ERROR 07	Address book initialization error																												
ERROR 08	Department initialization error																												
ERROR 09	Document box initialization error																												
ERROR 0a	Permissibility initialization error																												
ERROR 0b	Job log initialization error																												
ERROR 20	Engine initialization error																												
ERROR 40	Scanner initialization error																												
U024	<p>HDD formatting</p> <p>Description Initializes the HDD. In addition, the following settings are also initialized by initializing the HDD. System menu (user login administration, job accounting, address book, one-touch keys and document box etc.), shortcuts and panel programs Initializing the HDD will cause installed applications to be deleted. Reinstall applications as necessary after initializing the HDD.</p> <p>Purpose To initialize the HDD when replacing the HDD after shipping.</p> <p>Method</p> <ol style="list-style-type: none"> 1. Press the start key. 2. Press [EXECUTE] on the touch panel. 3. Press the start key to initialize the hard disk. 4. Turn the main power switch off and on. 																												

Maintenance item No.	Description																				
U030	<p>Checking motor operation</p> <p>Description Drives each motor.</p> <p>Purpose To check the operation of each motor.</p> <p>Method</p> <ol style="list-style-type: none"> 1. Press the start key. 2. Select the motor to be operated. 3. Press the start key. The operation starts. <table border="1" data-bbox="333 571 1398 819"> <thead> <tr> <th>Display</th> <th>Operation</th> </tr> </thead> <tbody> <tr> <td>MAIN</td> <td>Main motor (MM) is turned ON</td> </tr> <tr> <td>FEED</td> <td>Paper feed motor (PFM) is turned ON</td> </tr> <tr> <td>EJECT(FW)</td> <td>Eject motor (EM) is turned on clockwise</td> </tr> <tr> <td>EJECT(REV)</td> <td>Eject motor (EM) is turned on counterclockwise</td> </tr> <tr> <td>DRUM</td> <td>Drum motor (DRM) is turned ON</td> </tr> </tbody> </table> <ol style="list-style-type: none"> 4. To stop operation, press the stop key. <p>Completion Press the stop key. The screen for selecting a maintenance item No. is displayed.</p>	Display	Operation	MAIN	Main motor (MM) is turned ON	FEED	Paper feed motor (PFM) is turned ON	EJECT(FW)	Eject motor (EM) is turned on clockwise	EJECT(REV)	Eject motor (EM) is turned on counterclockwise	DRUM	Drum motor (DRM) is turned ON								
Display	Operation																				
MAIN	Main motor (MM) is turned ON																				
FEED	Paper feed motor (PFM) is turned ON																				
EJECT(FW)	Eject motor (EM) is turned on clockwise																				
EJECT(REV)	Eject motor (EM) is turned on counterclockwise																				
DRUM	Drum motor (DRM) is turned ON																				
U031	<p>Checking switches for paper conveying</p> <p>Description Displays the on-off status of each paper detection switch on the paper path.</p> <p>Purpose To check if the switches for paper conveying operate correctly.</p> <p>Method</p> <ol style="list-style-type: none"> 1. Press the start key. 2. Turn each switch on and off manually to check the status. When a switch is detected to be in the ON position, the display for that switch will be highlighted. <table border="1" data-bbox="333 1256 1398 1671"> <thead> <tr> <th>Display</th> <th>Switches</th> </tr> </thead> <tbody> <tr> <td>FEED1</td> <td>Feed switch 1 (FSW1)</td> </tr> <tr> <td>FEED2</td> <td>Feed switch 2 (FSW2)</td> </tr> <tr> <td>FEED3</td> <td>Feed switch 3 (FSW3)</td> </tr> <tr> <td>MP TRAY</td> <td>MP feed switch (MPFSW)</td> </tr> <tr> <td>REGIST</td> <td>Registration switch (RSW)</td> </tr> <tr> <td>EJECT</td> <td>Eject switch (ESW)</td> </tr> <tr> <td>BRANCH</td> <td>Feedshift switch (FSSW)</td> </tr> <tr> <td>DUPLEX</td> <td>Duplex paper conveying switch (DUPPCSW)</td> </tr> <tr> <td>JOB SEPARATOR</td> <td>Job separator eject switch (JESW)*</td> </tr> </tbody> </table> <p>*: Optional.</p> <p>Completion Press the stop key. The screen for selecting a maintenance item No. is displayed.</p>	Display	Switches	FEED1	Feed switch 1 (FSW1)	FEED2	Feed switch 2 (FSW2)	FEED3	Feed switch 3 (FSW3)	MP TRAY	MP feed switch (MPFSW)	REGIST	Registration switch (RSW)	EJECT	Eject switch (ESW)	BRANCH	Feedshift switch (FSSW)	DUPLEX	Duplex paper conveying switch (DUPPCSW)	JOB SEPARATOR	Job separator eject switch (JESW)*
Display	Switches																				
FEED1	Feed switch 1 (FSW1)																				
FEED2	Feed switch 2 (FSW2)																				
FEED3	Feed switch 3 (FSW3)																				
MP TRAY	MP feed switch (MPFSW)																				
REGIST	Registration switch (RSW)																				
EJECT	Eject switch (ESW)																				
BRANCH	Feedshift switch (FSSW)																				
DUPLEX	Duplex paper conveying switch (DUPPCSW)																				
JOB SEPARATOR	Job separator eject switch (JESW)*																				

Maintenance item No.	Description																						
<p>U032</p>	<p>Checking clutch operation</p> <p>Description Turns each clutch on.</p> <p>Purpose To check the operation of each clutch.</p> <p>Method</p> <ol style="list-style-type: none"> 1. Press the start key. 2. Select the clutch to be operated. 3. Press the start key. The clutch turns on for 1 s. <table border="1" data-bbox="333 571 1398 1032"> <thead> <tr> <th>Display</th> <th>Clutches</th> </tr> </thead> <tbody> <tr> <td>PF1</td> <td>Paper feed clutch 1 (PFCL1)</td> </tr> <tr> <td>PF2</td> <td>Paper feed clutch 2 (PFCL2)</td> </tr> <tr> <td>PF MP TRAY</td> <td>MP paper feed clutch (MPPFCL)</td> </tr> <tr> <td>FEED1</td> <td>Feed clutch 1 (FCL1)</td> </tr> <tr> <td>FEED2</td> <td>Feed clutch 2 (FCL2)</td> </tr> <tr> <td>LIFT MP TRAY</td> <td>MP paper feed clutch (MPPFCL)</td> </tr> <tr> <td>FEED MP TRAY</td> <td>MP feed clutch (MPFCL)</td> </tr> <tr> <td>REGIST</td> <td>Registration clutch (RCL)</td> </tr> <tr> <td>DUPLEX</td> <td>Duplex feed clutch (DUPFCL)</td> </tr> <tr> <td>MOTOR ON</td> <td>The main motor (MM) and the paper feed motor (PFM) are turned on.</td> </tr> </tbody> </table> <ol style="list-style-type: none"> 4. To stop motor driving, press [MOTOR ON] again. <p>Completion Press the stop key. The screen for selecting a maintenance item No. is displayed.</p>	Display	Clutches	PF1	Paper feed clutch 1 (PFCL1)	PF2	Paper feed clutch 2 (PFCL2)	PF MP TRAY	MP paper feed clutch (MPPFCL)	FEED1	Feed clutch 1 (FCL1)	FEED2	Feed clutch 2 (FCL2)	LIFT MP TRAY	MP paper feed clutch (MPPFCL)	FEED MP TRAY	MP feed clutch (MPFCL)	REGIST	Registration clutch (RCL)	DUPLEX	Duplex feed clutch (DUPFCL)	MOTOR ON	The main motor (MM) and the paper feed motor (PFM) are turned on.
Display	Clutches																						
PF1	Paper feed clutch 1 (PFCL1)																						
PF2	Paper feed clutch 2 (PFCL2)																						
PF MP TRAY	MP paper feed clutch (MPPFCL)																						
FEED1	Feed clutch 1 (FCL1)																						
FEED2	Feed clutch 2 (FCL2)																						
LIFT MP TRAY	MP paper feed clutch (MPPFCL)																						
FEED MP TRAY	MP feed clutch (MPFCL)																						
REGIST	Registration clutch (RCL)																						
DUPLEX	Duplex feed clutch (DUPFCL)																						
MOTOR ON	The main motor (MM) and the paper feed motor (PFM) are turned on.																						
<p>U033</p>	<p>Checking solenoid operation</p> <p>Description Applies current to each solenoid in order to check its ON status.</p> <p>Purpose To check the operation of each solenoid.</p> <p>Method</p> <ol style="list-style-type: none"> 1. Press the start key. 2. Select the solenoid to be operated. 3. Press the start key. The solenoid turns on for 1 s. <table border="1" data-bbox="333 1473 1398 1644"> <thead> <tr> <th>Display</th> <th>Solenoids</th> </tr> </thead> <tbody> <tr> <td>BRANCH1</td> <td>Feedshift solenoid (FSSOL)</td> </tr> <tr> <td>BRANCH2</td> <td>Job feedshift solenoid (JFSSOL)*</td> </tr> <tr> <td>MOTOR ON</td> <td>The main motor (MM) and the paper feed motor (PFM) are turned on.</td> </tr> </tbody> </table> <p>*Optional.</p> <ol style="list-style-type: none"> 4. To stop motor driving, press [MOTOR ON] again. <p>Completion Press the stop key. The screen for selecting a maintenance item No. is displayed.</p>	Display	Solenoids	BRANCH1	Feedshift solenoid (FSSOL)	BRANCH2	Job feedshift solenoid (JFSSOL)*	MOTOR ON	The main motor (MM) and the paper feed motor (PFM) are turned on.														
Display	Solenoids																						
BRANCH1	Feedshift solenoid (FSSOL)																						
BRANCH2	Job feedshift solenoid (JFSSOL)*																						
MOTOR ON	The main motor (MM) and the paper feed motor (PFM) are turned on.																						

Maintenance item No.	Description																																									
<p>U034</p>	<p>Adjusting the print start timing</p> <p>Description Adjusts the leading edge registration or center line.</p> <p>Purpose Make the adjustment if there is a regular error between the leading edges of the copy image and original. Make the adjustment if there is a regular error between the center lines of the copy image and original.</p> <p>Method</p> <ol style="list-style-type: none"> 1. Press the start key. 2. Select the item to be adjusted. The setting screen for the selected item is displayed. <table border="1" data-bbox="331 562 1398 689"> <thead> <tr> <th>Display</th> <th>Description</th> </tr> </thead> <tbody> <tr> <td>LSU OUT TOP</td> <td>Leading edge registration adjustment</td> </tr> <tr> <td>LSU OUT LEFT</td> <td>Center line adjustment</td> </tr> </tbody> </table> <p>Adjustment: Leading edge registration adjustment</p> <ol style="list-style-type: none"> 1. Select the item to be adjusted. <table border="1" data-bbox="331 790 1398 1294"> <thead> <tr> <th>Display</th> <th>Description</th> <th>Setting range</th> <th>Initial setting</th> <th>Change in value per step</th> </tr> </thead> <tbody> <tr> <td>LSUOUT TOP MPT (L)</td> <td>Paper feed from MP tray (when large size paper is used)</td> <td>-10.0 to 30.0</td> <td>0</td> <td>0.1 mm</td> </tr> <tr> <td>LSUOUT TOP CAS (L)</td> <td>Paper feed from cassette (when large size paper is used)</td> <td>-10.0 to 30.0</td> <td>0</td> <td>0.1 mm</td> </tr> <tr> <td>LSUOUT TOP DUP (L)</td> <td>Duplex mode (second) (when large size paper is used)</td> <td>-10.0 to 30.0</td> <td>0</td> <td>0.1 mm</td> </tr> <tr> <td>LSUOUT TOP MPT (S)</td> <td>Paper feed from MP tray (when small size paper is used)</td> <td>-10.0 to 30.0</td> <td>0</td> <td>0.1 mm</td> </tr> <tr> <td>LSUOUT TOP CAS (S)</td> <td>Paper feed from cassette (when small size paper is used)</td> <td>-10.0 to 30.0</td> <td>0</td> <td>0.1 mm</td> </tr> <tr> <td>LSUOUT TOP DUP (S)</td> <td>Duplex mode (second) (when small size paper is used)</td> <td>-10.0 to 30.0</td> <td>0</td> <td>0.1 mm</td> </tr> </tbody> </table> <p>Large size: 218 mm or more in width of paper.</p> <ol style="list-style-type: none"> 2. Press the system menu key. 3. Press the start key to output a test pattern. 4. Press the system menu key. 5. Change the setting value using the +/- or numeric keys. For output example 1, increase the value. For output example 2, decrease the value. <div data-bbox="363 1496 1177 1816" style="text-align: center;"> <p>Leading edge registration (20 ± 1.0 mm)</p> <p>Correct image Output example 1 Output example 2</p> </div> <p>Figure 1-3-4</p> <ol style="list-style-type: none"> 6. Press the start key. The value is set. <p>Remark When changing the setting value of [Large] each item is modified, equal to amount of the value which is changed adds also the value of [Small] each item and is pulled.</p>	Display	Description	LSU OUT TOP	Leading edge registration adjustment	LSU OUT LEFT	Center line adjustment	Display	Description	Setting range	Initial setting	Change in value per step	LSUOUT TOP MPT (L)	Paper feed from MP tray (when large size paper is used)	-10.0 to 30.0	0	0.1 mm	LSUOUT TOP CAS (L)	Paper feed from cassette (when large size paper is used)	-10.0 to 30.0	0	0.1 mm	LSUOUT TOP DUP (L)	Duplex mode (second) (when large size paper is used)	-10.0 to 30.0	0	0.1 mm	LSUOUT TOP MPT (S)	Paper feed from MP tray (when small size paper is used)	-10.0 to 30.0	0	0.1 mm	LSUOUT TOP CAS (S)	Paper feed from cassette (when small size paper is used)	-10.0 to 30.0	0	0.1 mm	LSUOUT TOP DUP (S)	Duplex mode (second) (when small size paper is used)	-10.0 to 30.0	0	0.1 mm
Display	Description																																									
LSU OUT TOP	Leading edge registration adjustment																																									
LSU OUT LEFT	Center line adjustment																																									
Display	Description	Setting range	Initial setting	Change in value per step																																						
LSUOUT TOP MPT (L)	Paper feed from MP tray (when large size paper is used)	-10.0 to 30.0	0	0.1 mm																																						
LSUOUT TOP CAS (L)	Paper feed from cassette (when large size paper is used)	-10.0 to 30.0	0	0.1 mm																																						
LSUOUT TOP DUP (L)	Duplex mode (second) (when large size paper is used)	-10.0 to 30.0	0	0.1 mm																																						
LSUOUT TOP MPT (S)	Paper feed from MP tray (when small size paper is used)	-10.0 to 30.0	0	0.1 mm																																						
LSUOUT TOP CAS (S)	Paper feed from cassette (when small size paper is used)	-10.0 to 30.0	0	0.1 mm																																						
LSUOUT TOP DUP (S)	Duplex mode (second) (when small size paper is used)	-10.0 to 30.0	0	0.1 mm																																						

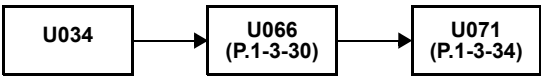
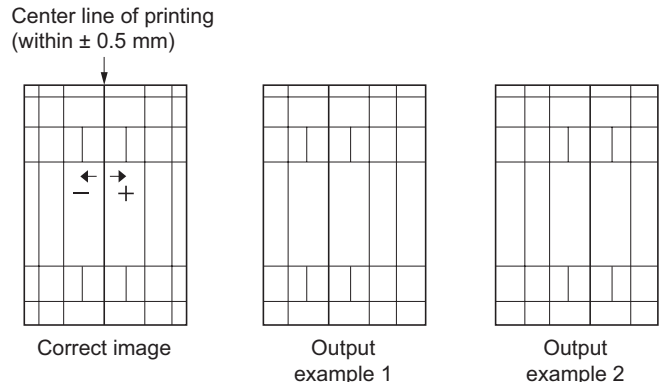
Maintenance item No.	Description																																			
<p>U034</p>	<p>Caution Check the copy image after the adjustment. If the image is still incorrect, perform the following adjustments in maintenance mode.</p> <div style="text-align: center;">  </div> <p>Adjustment: Center line adjustment</p> <ol style="list-style-type: none"> Select the item to be adjusted. <table border="1" data-bbox="331 537 1396 1041"> <thead> <tr> <th>Display</th> <th>Description</th> <th>Setting range</th> <th>Initial setting</th> <th>Change in value per step</th> </tr> </thead> <tbody> <tr> <td>LSUOUT LEFT (MPT)</td> <td>Paper feed from MP tray</td> <td>-10.0 to 10.0</td> <td>0</td> <td>0.1 mm</td> </tr> <tr> <td>LSUOUT LEFT (CAS 1)</td> <td>Paper feed from cassette 1</td> <td>-10.0 to 10.0</td> <td>0</td> <td>0.1 mm</td> </tr> <tr> <td>LSUOUT LEFT (CAS 2)</td> <td>Paper feed from cassette 2</td> <td>-10.0 to 10.0</td> <td>0</td> <td>0.1 mm</td> </tr> <tr> <td>LSUOUT LEFT (CAS 3)</td> <td>Paper feed from optional cassette 3</td> <td>-10.0 to 10.0</td> <td>0</td> <td>0.1 mm</td> </tr> <tr> <td>LSUOUT LEFT (CAS 4)</td> <td>Paper feed from optional cassette 4</td> <td>-10.0 to 10.0</td> <td>0</td> <td>0.1 mm</td> </tr> <tr> <td>LSUOUT LEFT (DUP)</td> <td>Duplex mode (second)</td> <td>-10.0 to 10.0</td> <td>0</td> <td>0.1 mm</td> </tr> </tbody> </table> <ol style="list-style-type: none"> Press the system menu key. Press the start key to output a test pattern. Press the system menu key. Change the setting value using the +/- or numeric keys. For output example 1, increase the value. For output example 2, decrease the value. <div style="text-align: center;">  </div> <p>Figure 1-3-5</p> <ol style="list-style-type: none"> Press the start key. The value is set. <p>Remark If the setting value for feeding from the MP tray is changed, the difference from the former value is added to or subtracted from the values of other items.</p>	Display	Description	Setting range	Initial setting	Change in value per step	LSUOUT LEFT (MPT)	Paper feed from MP tray	-10.0 to 10.0	0	0.1 mm	LSUOUT LEFT (CAS 1)	Paper feed from cassette 1	-10.0 to 10.0	0	0.1 mm	LSUOUT LEFT (CAS 2)	Paper feed from cassette 2	-10.0 to 10.0	0	0.1 mm	LSUOUT LEFT (CAS 3)	Paper feed from optional cassette 3	-10.0 to 10.0	0	0.1 mm	LSUOUT LEFT (CAS 4)	Paper feed from optional cassette 4	-10.0 to 10.0	0	0.1 mm	LSUOUT LEFT (DUP)	Duplex mode (second)	-10.0 to 10.0	0	0.1 mm
Display	Description	Setting range	Initial setting	Change in value per step																																
LSUOUT LEFT (MPT)	Paper feed from MP tray	-10.0 to 10.0	0	0.1 mm																																
LSUOUT LEFT (CAS 1)	Paper feed from cassette 1	-10.0 to 10.0	0	0.1 mm																																
LSUOUT LEFT (CAS 2)	Paper feed from cassette 2	-10.0 to 10.0	0	0.1 mm																																
LSUOUT LEFT (CAS 3)	Paper feed from optional cassette 3	-10.0 to 10.0	0	0.1 mm																																
LSUOUT LEFT (CAS 4)	Paper feed from optional cassette 4	-10.0 to 10.0	0	0.1 mm																																
LSUOUT LEFT (DUP)	Duplex mode (second)	-10.0 to 10.0	0	0.1 mm																																

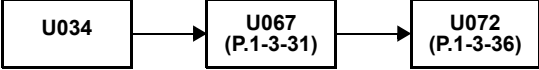

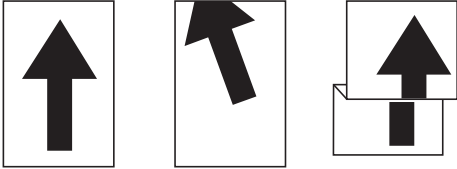
Maintenance item No.	Description														
<p>U034</p>	<p>Caution Check the copy image after the adjustment. If the image is still incorrect, perform the following adjustments in maintenance mode.</p> <div style="text-align: center;">  <pre> graph LR U034 --> U067["U067 (P.1-3-31)"] U067 --> U072["U072 (P.1-3-36)"] </pre> </div> <p>Completion Press the stop key. The screen for selecting a maintenance item No. is displayed.</p>														
<p>U035</p>	<p>Setting the printing area for folio paper Description Changes the printing area for copying on folio paper. Purpose To prevent cropped images on the trailing edge or left/right side of copy paper by setting the actual printing area for folio paper.</p> <p>Setting</p> <ol style="list-style-type: none"> 1. Press the start key. 2. Select the item to be set. 3. Change the setting using the +/- keys. <table border="1" data-bbox="336 871 1398 994"> <thead> <tr> <th>Display</th> <th>Setting</th> <th>Setting range</th> <th>Initial setting</th> </tr> </thead> <tbody> <tr> <td>LENGTH DATA</td> <td>Length</td> <td>330 to 356 mm</td> <td>330</td> </tr> <tr> <td>WIDTH DATA</td> <td>Width</td> <td>200 to 220 mm</td> <td>210</td> </tr> </tbody> </table> <ol style="list-style-type: none"> 4. Press the start key. The value is set. <p>Completion Press the stop key. The screen for selecting a maintenance item No. is displayed.</p>	Display	Setting	Setting range	Initial setting	LENGTH DATA	Length	330 to 356 mm	330	WIDTH DATA	Width	200 to 220 mm	210		
Display	Setting	Setting range	Initial setting												
LENGTH DATA	Length	330 to 356 mm	330												
WIDTH DATA	Width	200 to 220 mm	210												
<p>U037</p>	<p>Checking the operation of the fan motors Description Drives the fan motors. Description To check the operation of the fan motors.</p> <p>Method</p> <ol style="list-style-type: none"> 1. Press the start key. 2. Select the fan motor to be operated. 3. Press the start key. The operation starts. <table border="1" data-bbox="336 1429 1398 1720"> <thead> <tr> <th>Display</th> <th>Operation</th> </tr> </thead> <tbody> <tr> <td>Right Fan</td> <td>Developing fan motor (DEVFM) is turned on</td> </tr> <tr> <td>Rear Fan</td> <td>Fuser fan motor (FUFM) is turned on</td> </tr> <tr> <td>Conveying Fan</td> <td>Paper conveying fan motor 1, 2 (PCFM1, 2) are turned on</td> </tr> <tr> <td>Power Source Fan</td> <td>Power source fan motor (PSFM) are turned on</td> </tr> <tr> <td>Eject Fan</td> <td>Eject fan motor (EFM) is turned on</td> </tr> <tr> <td>ALL</td> <td>All fan motor are turned on</td> </tr> </tbody> </table> <ol style="list-style-type: none"> 4. To stop operation, press the stop key. <p>Completion Press the stop key. The screen for selecting a maintenance item No. is displayed.</p>	Display	Operation	Right Fan	Developing fan motor (DEVFM) is turned on	Rear Fan	Fuser fan motor (FUFM) is turned on	Conveying Fan	Paper conveying fan motor 1, 2 (PCFM1, 2) are turned on	Power Source Fan	Power source fan motor (PSFM) are turned on	Eject Fan	Eject fan motor (EFM) is turned on	ALL	All fan motor are turned on
Display	Operation														
Right Fan	Developing fan motor (DEVFM) is turned on														
Rear Fan	Fuser fan motor (FUFM) is turned on														
Conveying Fan	Paper conveying fan motor 1, 2 (PCFM1, 2) are turned on														
Power Source Fan	Power source fan motor (PSFM) are turned on														
Eject Fan	Eject fan motor (EFM) is turned on														
ALL	All fan motor are turned on														

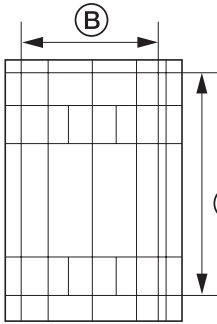
Maintenance item No.	Description																								
U051	<p>Adjusting the deflection in the paper</p> <p>Description Adjusts the deflection in the paper.</p> <p>Purpose Make the adjustment if the leading edge of the copy image is missing or varies randomly, or if the copy paper is Z-folded.</p> <p>Adjustment</p> <ol style="list-style-type: none"> 1. Press the start key. 2. Select the item to be adjusted. <table border="1" data-bbox="333 562 1398 813"> <thead> <tr> <th>Display</th> <th>Description</th> <th>Setting range</th> <th>Initial setting</th> </tr> </thead> <tbody> <tr> <td>MPT</td> <td>Paper feed from MP tray</td> <td>-50 to 127</td> <td>0</td> </tr> <tr> <td>CASSETTE1</td> <td>Paper feed from cassette 1</td> <td>-50 to 127</td> <td>50</td> </tr> <tr> <td>CASSETTE2</td> <td>Paper feed from cassette 2</td> <td>-50 to 127</td> <td>50</td> </tr> <tr> <td>DUPLEX</td> <td>Duplex mode (second)</td> <td>-50 to 127</td> <td>40</td> </tr> <tr> <td>MPT (THICK)</td> <td>Paper feed from MP tray (thick paper)</td> <td>-50 to 127</td> <td>10</td> </tr> </tbody> </table> <ol style="list-style-type: none"> 3. Press the system menu key. 4. Place an original and press the start key to make a test copy. 5. Press the system menu key. 6. Change the setting value using the +/- or numeric keys. For output example 1, increase the value. For output example 2, decrease the value. The greater the value, the larger the deflection; the smaller the value, the smaller the deflection. <div data-bbox="624 1059 1082 1283" style="text-align: center;">  <p style="display: flex; justify-content: space-around; margin-top: 5px;"> Original Copy example 1 Copy example 2 </p> </div> <p>7. Press the start key. The value is set.</p> <p>Completion Press the stop key. The indication for selecting a maintenance item No. appears.</p>	Display	Description	Setting range	Initial setting	MPT	Paper feed from MP tray	-50 to 127	0	CASSETTE1	Paper feed from cassette 1	-50 to 127	50	CASSETTE2	Paper feed from cassette 2	-50 to 127	50	DUPLEX	Duplex mode (second)	-50 to 127	40	MPT (THICK)	Paper feed from MP tray (thick paper)	-50 to 127	10
Display	Description	Setting range	Initial setting																						
MPT	Paper feed from MP tray	-50 to 127	0																						
CASSETTE1	Paper feed from cassette 1	-50 to 127	50																						
CASSETTE2	Paper feed from cassette 2	-50 to 127	50																						
DUPLEX	Duplex mode (second)	-50 to 127	40																						
MPT (THICK)	Paper feed from MP tray (thick paper)	-50 to 127	10																						

Maintenance item No.	Description																																
<p>U053</p>	<p>Setting the adjustment of the motor speed</p> <p>Description Performs fine adjustment of the speeds of the motors.</p> <p>Purpose To adjust the speed of the respective motors when the magnification is not correct.</p> <p>Method</p> <ol style="list-style-type: none"> 1. Press the start key. 2. Select the item to be adjusted. <table border="1" data-bbox="331 533 1398 927"> <thead> <tr> <th>Display</th> <th>Description</th> <th>Setting range</th> <th>Initial setting</th> </tr> </thead> <tbody> <tr> <td>ALL</td> <td>Main motor (MM) speed adjustment</td> <td>-40 to 40</td> <td>0</td> </tr> <tr> <td>MAIN MOTOR</td> <td>Main motor (MM) speed adjustment</td> <td>-40 to 40</td> <td>-1</td> </tr> <tr> <td>DRUM MOTOR</td> <td>Drum motor (DRM) speed adjustment</td> <td>-40 to 40</td> <td>0</td> </tr> <tr> <td>FEED MOTOR</td> <td>Paper feed motor (PFM) speed adjustment</td> <td>-40 to 40</td> <td>-2</td> </tr> <tr> <td>EJECT MOTOR</td> <td>Eject motor (EM) speed adjustment</td> <td>-40 to 40</td> <td>2</td> </tr> <tr> <td>POLYGON MOTOR</td> <td>Polygon motor (PM) speed adjustment</td> <td>-20 to 20</td> <td>-8</td> </tr> <tr> <td>DF MOTOR</td> <td>Paper conveying motor (PCM)* speed adjustment</td> <td>-40 to 40</td> <td>0</td> </tr> </tbody> </table> <p>*Optional.</p> <p>Adjustment</p> <ol style="list-style-type: none"> 1. Press the system menu key. 2. Press the start key to output an A3/Ledger VTC pattern. <div data-bbox="612 1106 1382 1429" style="text-align: center;">  <p>Correct values for an A3/Ledger output are: A = 350 ± 1.4 mm B = 250 ± 1.0 mm</p> </div> <p>Figure 1-3-7</p> <ol style="list-style-type: none"> 3. Press the system menu key. 4. Change the setting value using the +/- or numeric keys. A: Main motor speed adjustment Increasing the setting makes the image longer in the auxiliary scanning direction, and decreasing it makes the image shorter in the auxiliary scanning direction. B: Polygon motor speed adjustment Increasing the setting makes the image shorter in the main scanning direction, and decreasing it makes the image longer in the main scanning direction. 5. Press the start key. The value is set. <p>Completion Press the stop key. The indication for selecting a maintenance item No. appears.</p>	Display	Description	Setting range	Initial setting	ALL	Main motor (MM) speed adjustment	-40 to 40	0	MAIN MOTOR	Main motor (MM) speed adjustment	-40 to 40	-1	DRUM MOTOR	Drum motor (DRM) speed adjustment	-40 to 40	0	FEED MOTOR	Paper feed motor (PFM) speed adjustment	-40 to 40	-2	EJECT MOTOR	Eject motor (EM) speed adjustment	-40 to 40	2	POLYGON MOTOR	Polygon motor (PM) speed adjustment	-20 to 20	-8	DF MOTOR	Paper conveying motor (PCM)* speed adjustment	-40 to 40	0
Display	Description	Setting range	Initial setting																														
ALL	Main motor (MM) speed adjustment	-40 to 40	0																														
MAIN MOTOR	Main motor (MM) speed adjustment	-40 to 40	-1																														
DRUM MOTOR	Drum motor (DRM) speed adjustment	-40 to 40	0																														
FEED MOTOR	Paper feed motor (PFM) speed adjustment	-40 to 40	-2																														
EJECT MOTOR	Eject motor (EM) speed adjustment	-40 to 40	2																														
POLYGON MOTOR	Polygon motor (PM) speed adjustment	-20 to 20	-8																														
DF MOTOR	Paper conveying motor (PCM)* speed adjustment	-40 to 40	0																														

Maintenance item No.	Description								
U055	<p>Setting the motor periodic drive</p> <p>Description Specifies ON/OFF the drum small rotation mode.</p> <p>Purpose Set to ON if dribbling occurs on the image.</p> <p>Setting</p> <ol style="list-style-type: none"> 1. Press the start key. 2. Select ON or OFF. <table border="1" data-bbox="335 533 1398 660"> <thead> <tr> <th>Display</th> <th>Description</th> </tr> </thead> <tbody> <tr> <td>ON</td> <td>Drum small rotation mode ON</td> </tr> <tr> <td>OFF</td> <td>Drum small rotation mode OFF</td> </tr> </tbody> </table> <p>Initial setting: OFF</p> <ol style="list-style-type: none"> 3. Press the start key. The setting is set. <p>Completion Press the stop key. The screen for selecting a maintenance item No. is displayed.</p>	Display	Description	ON	Drum small rotation mode ON	OFF	Drum small rotation mode OFF		
Display	Description								
ON	Drum small rotation mode ON								
OFF	Drum small rotation mode OFF								
U059	<p>Setting fan mode</p> <p>Description Sets the time of period cooling fan motor 1 is driven.</p> <p>Purpose To be executed as required.</p> <p>Method</p> <ol style="list-style-type: none"> 1. Press the start key. 2. Change the setting using the +/- keys. <table border="1" data-bbox="335 1093 1398 1238"> <thead> <tr> <th>Display</th> <th>Description</th> <th>Setting range</th> <th>Initial setting</th> </tr> </thead> <tbody> <tr> <td>FAN1</td> <td>Time of period the fan is driven after printing is completed</td> <td>0 to 250 (s)</td> <td>45</td> </tr> </tbody> </table> <ol style="list-style-type: none"> 3. Press the start key. The value is set. <p>Completion Press the stop key. The screen for selecting a maintenance item No. is displayed.</p>	Display	Description	Setting range	Initial setting	FAN1	Time of period the fan is driven after printing is completed	0 to 250 (s)	45
Display	Description	Setting range	Initial setting						
FAN1	Time of period the fan is driven after printing is completed	0 to 250 (s)	45						

Maintenance item No.	Description										
<p>U061</p>	<p>Turning the exposure lamp on Description Turns the exposure lamp on. Purpose To check the exposure lamp. Method 1. Press the start key. 2. Select [CCD]. 3. Press the start key. The lamp lights. 4. To turn the lamp off, press the stop key. Completion Press the stop key. The screen for selecting a maintenance item No. is displayed.</p>										
<p>U063</p>	<p>Adjusting the shading position Description Changes the shading position of the scanner. Purpose Used when white lines continue to appear longitudinally on the image after the shading plate is cleaned. This is due to flaws or stains inside the shading plate. To prevent this problem, the shading position should be changed so that shading is possible without being affected by the flaws or stains. Method 1. Press the start key. 2. Change the setting using the +/- or numeric keys.</p> <table border="1" data-bbox="333 1014 1398 1128"> <thead> <tr> <th>Display</th> <th>Description</th> <th>Setting range</th> <th>Initial setting</th> <th>Change in value per step</th> </tr> </thead> <tbody> <tr> <td>SHADING POSITION</td> <td>Shading position</td> <td>0 to 24</td> <td>0</td> <td>0.11 mm</td> </tr> </tbody> </table> <p>Increasing the setting moves the shading position toward the machine left, and decreasing it moves the position toward the machine right. 3. Press the start key. The value is set. Supplement While this maintenance item is being executed, copying from an original is available in interrupt copying mode (which is activated by pressing the system menu key). Completion Press the stop key. The screen for selecting a maintenance item No. is displayed.</p>	Display	Description	Setting range	Initial setting	Change in value per step	SHADING POSITION	Shading position	0 to 24	0	0.11 mm
Display	Description	Setting range	Initial setting	Change in value per step							
SHADING POSITION	Shading position	0 to 24	0	0.11 mm							

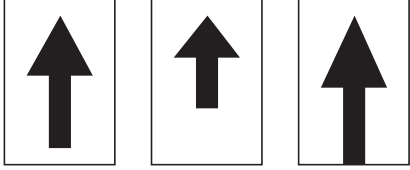
Maintenance item No.	Description															
<p>U065</p>	<p>Adjusting the scanner magnification</p> <p>Description Adjusts the magnification of the original scanning.</p> <p>Purpose Make the adjustment if the magnification in the main scanning direction is incorrect. Make the adjustment if the magnification in the auxiliary scanning direction is incorrect.</p> <p>Caution Adjust the magnification of the scanner in the following order.</p> <div style="text-align: center;">  </div> <p>Method</p> <ol style="list-style-type: none"> 1. Press the start key. 2. Select the item to be adjusted. <table border="1" data-bbox="333 741 1398 958"> <thead> <tr> <th>Display</th> <th>Description</th> <th>Setting range</th> <th>Initial setting</th> <th>Change in value per step</th> </tr> </thead> <tbody> <tr> <td>Y SCAN ZOOM</td> <td>Scanner magnification in the main scanning direction</td> <td>-15 to 15</td> <td>0</td> <td>0.1 %</td> </tr> <tr> <td>X SCAN ZOOM</td> <td>Scanner magnification in the auxiliary scanning direction</td> <td>-25 to 25</td> <td>0</td> <td>0.05 %</td> </tr> </tbody> </table> <p>Adjustment: Main scanning direction</p> <ol style="list-style-type: none"> 1. Press the system menu key. 2. Place an original and press the start key to make a test copy. 3. Press the system menu key. 4. Change the setting value using the +/- or numeric keys. For copy example 1, increase the value. For copy example 2, decrease the value. <div style="text-align: center;">  <p>Original Copy example 1 Copy example 2</p> </div> <p>Figure 1-3-8</p> <ol style="list-style-type: none"> 5. Press the start key. The value is set. <p>Adjustment: Auxiliary scanning direction</p> <ol style="list-style-type: none"> 1. Press the system menu key. 2. Place an original and press the start key to make a test copy. 3. Press the system menu key. 4. Change the setting value using the +/- or numeric keys. For copy example 1, increase the value. For copy example 2, decrease the value. <div style="text-align: center;">  <p>Original Copy example 1 Copy example 2</p> </div> <p>Figure 1-3-9</p> <ol style="list-style-type: none"> 5. Press the start key. The value is set. 	Display	Description	Setting range	Initial setting	Change in value per step	Y SCAN ZOOM	Scanner magnification in the main scanning direction	-15 to 15	0	0.1 %	X SCAN ZOOM	Scanner magnification in the auxiliary scanning direction	-25 to 25	0	0.05 %
Display	Description	Setting range	Initial setting	Change in value per step												
Y SCAN ZOOM	Scanner magnification in the main scanning direction	-15 to 15	0	0.1 %												
X SCAN ZOOM	Scanner magnification in the auxiliary scanning direction	-25 to 25	0	0.05 %												

Maintenance item No.	Description															
U065	<p>Completion Press the stop key. The screen for selecting a maintenance item No. is displayed.</p>															
U066	<p>Adjusting the scanner leading edge registration Description Adjusts the scanner leading edge registration of the original scanning. Purpose Make the adjustment if there is a regular error between the leading edges of the copy image and original. Adjustment 1. Press the start key. 2. Select the item to be adjusted.</p> <table border="1" data-bbox="331 633 1398 819"> <thead> <tr> <th>Display</th> <th>Description</th> <th>Setting range</th> <th>Initial setting</th> <th>Change in value per step</th> </tr> </thead> <tbody> <tr> <td>FRONT</td> <td>Scanner leading edge registration</td> <td>-45 to 45</td> <td>0</td> <td>0.11 mm</td> </tr> <tr> <td>TAIL</td> <td>Scanner leading edge registration (rotate copying)</td> <td>-45 to 45</td> <td>0</td> <td>0.11 mm</td> </tr> </tbody> </table> <p>3. Press the system menu key. 4. Place an original and press the start key to make a test copy. 5. Press the system menu key. 6. Change the setting value using the +/- or numeric keys. For copy example 1, increase the value. For copy example 2, decrease the value.</p> <div data-bbox="625 1008 1075 1308" data-label="Image"> </div> <p style="text-align: center;">Figure 1-3-10</p> <p>7. Press the start key. The value is set.</p> <p>Caution Check the copy image after the adjustment. If the image is still incorrect, perform the following adjustments in maintenance mode.</p> <pre> graph LR U066[U066] --> U403[U403 (P.1-3-72)] U403 --> U071[U071 (P.1-3-34)] U071 --> U404[U404 (P.1-3-73)] </pre> <p>Completion Press the stop key. The screen for selecting a maintenance item No. is displayed.</p>	Display	Description	Setting range	Initial setting	Change in value per step	FRONT	Scanner leading edge registration	-45 to 45	0	0.11 mm	TAIL	Scanner leading edge registration (rotate copying)	-45 to 45	0	0.11 mm
Display	Description	Setting range	Initial setting	Change in value per step												
FRONT	Scanner leading edge registration	-45 to 45	0	0.11 mm												
TAIL	Scanner leading edge registration (rotate copying)	-45 to 45	0	0.11 mm												

Maintenance item No.	Description																						
<p>U067</p>	<p>Adjusting the scanner center line</p> <p>Description Adjusts the scanner center line of the original scanning.</p> <p>Purpose Make the adjustment if there is a regular error between the center lines of the copy image and original.</p> <p>Adjustment</p> <ol style="list-style-type: none"> 1. Press the start key. 2. Select the item to be adjusted. <table border="1" data-bbox="331 533 1398 689"> <thead> <tr> <th>Display</th> <th>Description</th> <th>Setting range</th> <th>Initial setting</th> <th>Change in value per step</th> </tr> </thead> <tbody> <tr> <td>FRONT</td> <td>Scanner center line</td> <td>-40 to 40</td> <td>0</td> <td>0.08 mm</td> </tr> <tr> <td>ROTATE</td> <td>Scanner center line (rotate copying)</td> <td>-40 to 40</td> <td>0</td> <td>0.08 mm</td> </tr> </tbody> </table> <ol style="list-style-type: none"> 3. Press the system menu key. 4. Place an original and press the start key to make a test copy. 5. Press the system menu key. 6. Change the setting value using the +/- or numeric keys. For copy example 1, increase the value. For copy example 2, decrease the value. <div data-bbox="635 869 1066 1151" style="text-align: center;"> <p>Scanner center line</p> <p>Original Copy example 1 Copy example 2</p> </div> <p style="text-align: center;">Figure 1-3-11</p> <ol style="list-style-type: none"> 7. Press the start key. The value is set. <p>Caution Check the copy image after the adjustment. If the image is still incorrect, perform the following adjustments in maintenance mode.</p> <div data-bbox="284 1393 1034 1464" style="text-align: center;"> <table border="1"> <tr> <td style="padding: 5px;">U067</td> <td style="padding: 5px;">→</td> <td style="padding: 5px;">U403 (P.1-3-72)</td> <td style="padding: 5px;">→</td> <td style="padding: 5px;">U072 (P.1-3-36)</td> <td style="padding: 5px;">→</td> <td style="padding: 5px;">U404 (P.1-3-73)</td> </tr> </table> </div> <p>Completion Press the stop key. The screen for selecting a maintenance item No. is displayed.</p>	Display	Description	Setting range	Initial setting	Change in value per step	FRONT	Scanner center line	-40 to 40	0	0.08 mm	ROTATE	Scanner center line (rotate copying)	-40 to 40	0	0.08 mm	U067	→	U403 (P.1-3-72)	→	U072 (P.1-3-36)	→	U404 (P.1-3-73)
Display	Description	Setting range	Initial setting	Change in value per step																			
FRONT	Scanner center line	-40 to 40	0	0.08 mm																			
ROTATE	Scanner center line (rotate copying)	-40 to 40	0	0.08 mm																			
U067	→	U403 (P.1-3-72)	→	U072 (P.1-3-36)	→	U404 (P.1-3-73)																	

Maintenance item No.	Description															
U068	<p>Adjusting the scanning position for originals from the DP</p> <p>Description Adjusts the position for scanning originals from the DP. Performs the test copy at the four scanning positions after adjusting.</p> <p>Purpose Used when the image fogging occurs because the scanning position is not proper when the DP is used. Run U071 to adjust the timing of DP leading edge when the scanning position is changed.</p> <p>Setting</p> <ol style="list-style-type: none"> 1. Press the start key. <table border="1" data-bbox="333 564 1398 779"> <thead> <tr> <th>Display</th> <th>Description</th> <th>Setting range</th> <th>Initial setting</th> <th>Change in value per step</th> </tr> </thead> <tbody> <tr> <td>DP READ</td> <td>Starting position adjustment for scanning originals</td> <td>-55 to 55</td> <td>0</td> <td>0.11 mm</td> </tr> <tr> <td>BLACK LINE</td> <td>Scanning position for the test copy originals</td> <td>0 to 3</td> <td>0</td> <td>-</td> </tr> </tbody> </table> <ol style="list-style-type: none"> 2. Select [DP READ] of the screen for selecting an item. 3. Change the setting using the +/- or numeric keys. When the setting value is increased, the scanning position moves to the right and it moves to the left when the setting value is decreased. 4. Press the start key. The value is set. 5. Select [BLACK LINE] of the screen for selecting an item. 6. Select the scanning position using the +/- or numeric keys. 7. Press the start key. The value is set. 8. Set the original (the one which density is known) in the DP and press the system menu key. The screen for the test copy mode is displayed. 9. Press the start key. Test copy is executed. 10. Perform the test copy at each scanning position with the setting value from 0 to 3 and check that no black line appears and the image is normally scanned. <p>Completion Press the stop key. The screen for selecting a maintenance item No. is displayed.</p>	Display	Description	Setting range	Initial setting	Change in value per step	DP READ	Starting position adjustment for scanning originals	-55 to 55	0	0.11 mm	BLACK LINE	Scanning position for the test copy originals	0 to 3	0	-
Display	Description	Setting range	Initial setting	Change in value per step												
DP READ	Starting position adjustment for scanning originals	-55 to 55	0	0.11 mm												
BLACK LINE	Scanning position for the test copy originals	0 to 3	0	-												

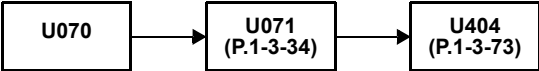
Maintenance item No.	Description															
<p>U070</p>	<p>Adjusting the DP magnification</p> <p>Description Adjusts the DP original scanning speed.</p> <p>Purpose Make the adjustment if the magnification is incorrect in the auxiliary scanning direction when the DP is used.</p> <p>Method</p> <ol style="list-style-type: none"> 1. Press the start key. 2. Select the item to be adjusted. <table border="1" data-bbox="331 533 1398 748"> <thead> <tr> <th>Display</th> <th>Description</th> <th>Setting range</th> <th>Initial setting</th> <th>Change in value per step</th> </tr> </thead> <tbody> <tr> <td>MOTOR ADJ (FRONT)</td> <td>Magnification in the auxiliary scanning direction (first side)</td> <td>-25 to 25</td> <td>0</td> <td>0.05 %</td> </tr> <tr> <td>MOTOR ADJ (BACK)</td> <td>Magnification in the auxiliary scanning direction (second side)</td> <td>-25 to 25</td> <td>0</td> <td>0.05 %</td> </tr> </tbody> </table> <p>Adjustment: Auxiliary scanning direction</p> <ol style="list-style-type: none"> 1. Press the system menu key. 2. Place an original on the DP and press the start key to make a test copy. 3. Press the system menu key. 4. Change the setting value using the +/- or numeric keys. For copy example 1, increase the value. For copy example 2, decrease the value. <div data-bbox="647 987 1056 1223" style="text-align: center;">  <p>Original Copy example 1 Copy example 2</p> </div> <p style="text-align: center;">Figure 1-3-12</p> <ol style="list-style-type: none"> 5. Press the start key. The value is set. <p>Caution Check the copy image after the adjustment. If the image is still incorrect, perform the following adjustments in maintenance mode.</p> <div data-bbox="288 1462 828 1532" style="text-align: center;">  <pre> graph LR U070[U070] --> U071[U071 (P.1-3-34)] U071 --> U404[U404 (P.1-3-73)] </pre> </div> <p>Completion Press the stop key. The screen for selecting a maintenance item No. is displayed.</p>	Display	Description	Setting range	Initial setting	Change in value per step	MOTOR ADJ (FRONT)	Magnification in the auxiliary scanning direction (first side)	-25 to 25	0	0.05 %	MOTOR ADJ (BACK)	Magnification in the auxiliary scanning direction (second side)	-25 to 25	0	0.05 %
Display	Description	Setting range	Initial setting	Change in value per step												
MOTOR ADJ (FRONT)	Magnification in the auxiliary scanning direction (first side)	-25 to 25	0	0.05 %												
MOTOR ADJ (BACK)	Magnification in the auxiliary scanning direction (second side)	-25 to 25	0	0.05 %												

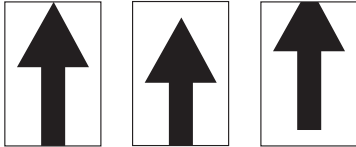
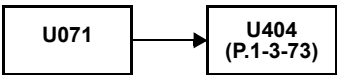
Maintenance item No.	Description																									
<p>U071</p> <p>Adjusting the DP scanning timing</p> <p>Description Adjusts the DP original scanning timing.</p> <p>Purpose Make the adjustment if there is a regular error between the leading or trailing edges of the original and the copy image when the DP is used.</p> <p>Method</p> <ol style="list-style-type: none"> 1. Press the start key. 2. Select the item to be adjusted. 	<table border="1"> <thead> <tr> <th>Display</th> <th>Description</th> <th>Setting range</th> <th>Initial setting</th> <th>Change in value per step</th> </tr> </thead> <tbody> <tr> <td>FRONT HEAD</td> <td>Leading edge registration (first side)</td> <td>-66 to 66</td> <td>0</td> <td>0.08 mm</td> </tr> <tr> <td>FRONT TAIL</td> <td>Trailing edge registration (first side)</td> <td>-66 to 66</td> <td>0</td> <td>0.08 mm</td> </tr> <tr> <td>BACK HEAD</td> <td>Leading edge registration (second side)</td> <td>-66 to 66</td> <td>0</td> <td>0.08 mm</td> </tr> <tr> <td>BACK TAIL</td> <td>Trailing edge registration (second side)</td> <td>-66 to 66</td> <td>0</td> <td>0.08 mm</td> </tr> </tbody> </table> <p>Adjustment: Leading edge registration</p> <ol style="list-style-type: none"> 1. Press the system menu key. 2. Place an original on the DP and press the start key to make a test copy. 3. Press the system menu key. 4. Change the setting value using the +/- or numeric keys. For copy example 1, increase the value. For copy example 2, decrease the value. <div style="text-align: center;">  <p>Original Copy example 1 Copy example 2</p> </div> <p style="text-align: center;">Figure 1-3-13</p> <ol style="list-style-type: none"> 5. Press the start key. The value is set. <p>Caution If the CCD first side is adjusted, check the CCD second side and if adjustment is required, carry out the adjustment. Check the copy image after the adjustment. If the image is still incorrect, perform the following adjustments in maintenance mode.</p> <div style="text-align: center;">  </div>	Display	Description	Setting range	Initial setting	Change in value per step	FRONT HEAD	Leading edge registration (first side)	-66 to 66	0	0.08 mm	FRONT TAIL	Trailing edge registration (first side)	-66 to 66	0	0.08 mm	BACK HEAD	Leading edge registration (second side)	-66 to 66	0	0.08 mm	BACK TAIL	Trailing edge registration (second side)	-66 to 66	0	0.08 mm
Display	Description	Setting range	Initial setting	Change in value per step																						
FRONT HEAD	Leading edge registration (first side)	-66 to 66	0	0.08 mm																						
FRONT TAIL	Trailing edge registration (first side)	-66 to 66	0	0.08 mm																						
BACK HEAD	Leading edge registration (second side)	-66 to 66	0	0.08 mm																						
BACK TAIL	Trailing edge registration (second side)	-66 to 66	0	0.08 mm																						







Maintenance item No.	Description
U071	<p>Adjustment: Trailing edge registration</p> <ol style="list-style-type: none"> 1. Press the system menu key. 2. Place an original on the DP and press the start key to make a test copy. 3. Press the system menu key. 4. Change the setting value using the +/- or numeric keys. For copy example 1, increase the value. For copy example 2, decrease the value. <div data-bbox="644 465 999 696" style="text-align: center;"> <p>Original Copy example 1 Copy example 2</p> </div> <p style="text-align: center;">Figure 1-3-14</p> <ol style="list-style-type: none"> 5. Press the start key. The value is set. <p>Caution If the CCD first side is adjusted, check the CCD second side and if adjustment is required, carry out the adjustment. Check the copy image after the adjustment. If the image is still incorrect, perform the following adjustments in maintenance mode.</p> <div data-bbox="288 994 624 1066" style="text-align: center;"> <pre> graph LR U071[U071] --> U404[U404 (P.1-3-73)] </pre> </div> <p>Completion Press the stop key. The screen for selecting a maintenance item No. is displayed.</p>

Maintenance item No.	Description															
<p>U072</p>	<p>Adjusting the DP center line</p> <p>Description Adjusts the scanning start position for the DP original.</p> <p>Purpose Make the adjustment if there is a regular error between the centers of the original and the copy image when the DP is used.</p> <p>Adjustment</p> <ol style="list-style-type: none"> 1. Press the start key. 2. Select the item to be adjusted. <table border="1" data-bbox="331 562 1398 719"> <thead> <tr> <th>Display</th> <th>Description</th> <th>Setting range</th> <th>Initial setting</th> <th>Change in value per step</th> </tr> </thead> <tbody> <tr> <td>FRONT</td> <td>DP center line (first side)</td> <td>-40 to 40</td> <td>0</td> <td>0.08 mm</td> </tr> <tr> <td>BACK</td> <td>DP center line (second side)</td> <td>-40 to 40</td> <td>0</td> <td>0.08 mm</td> </tr> </tbody> </table> <ol style="list-style-type: none"> 3. Press the system menu key. 4. Place an original on the DP and press the start key to make a test copy. 5. Press the system menu key. 6. Change the setting value using the +/- or numeric keys. For copy example 1, increase the value. For copy example 2, decrease the value. <div data-bbox="636 891 1066 1126" style="text-align: center;"> </div> <p style="text-align: center;">Figure 1-3-15</p> <ol style="list-style-type: none"> 7. Press the start key. The value is set. <p>Caution If the CCD first side is adjusted, check the CCD second side and if adjustment is required, carry out the adjustment. Check the copy image after the adjustment. If the image is still incorrect, perform the following adjustments in maintenance mode.</p> <div data-bbox="287 1431 624 1503" style="text-align: center;"> <pre> graph LR U072[U072] --> U404[U404 (P.1-3-73)] </pre> </div> <p>Completion Press the stop key. The screen for selecting a maintenance item No. is displayed.</p>	Display	Description	Setting range	Initial setting	Change in value per step	FRONT	DP center line (first side)	-40 to 40	0	0.08 mm	BACK	DP center line (second side)	-40 to 40	0	0.08 mm
Display	Description	Setting range	Initial setting	Change in value per step												
FRONT	DP center line (first side)	-40 to 40	0	0.08 mm												
BACK	DP center line (second side)	-40 to 40	0	0.08 mm												

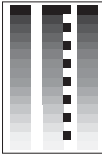
Maintenance item No.	Description																																																						
U073	<p>Checking scanner operation</p> <p>Description Simulates the scanner operation under arbitrary conditions.</p> <p>Purpose To check scanner operation.</p> <p>Start</p> <ol style="list-style-type: none"> 1. Press the start key. 2. Select the item to be operated. <table border="1" data-bbox="331 533 1398 741"> <thead> <tr> <th>Display</th> <th>Description</th> </tr> </thead> <tbody> <tr> <td>SCANNER MOTOR</td> <td>Scanner operation</td> </tr> <tr> <td>HOME POSITION</td> <td>Home position operation</td> </tr> <tr> <td>DUST CHECK</td> <td>Dust adhesion check operation with lamp on</td> </tr> <tr> <td>DP READING</td> <td>DP scanning position operation</td> </tr> </tbody> </table> <p>Setting: [SCANNER MOTOR]</p> <ol style="list-style-type: none"> 1. Select [SCANNER MOTOR]. 2. Select the item. 3. Change the setting using the +/- keys. <table border="1" data-bbox="331 904 1398 1072"> <thead> <tr> <th>Display</th> <th>Operating conditions</th> <th>Setting range</th> </tr> </thead> <tbody> <tr> <td>ZOOM</td> <td>Magnification</td> <td>25 to 400 %</td> </tr> <tr> <td>SIZE</td> <td>Original size</td> <td>See below.</td> </tr> <tr> <td>LAMP</td> <td>On and off of the exposure lamp</td> <td>0 (off) or 1 (on)</td> </tr> </tbody> </table> <p>Original sizes for each setting in SIZE</p> <table border="1" data-bbox="331 1122 1398 1438"> <thead> <tr> <th>Setting</th> <th>Paper size</th> <th>Setting</th> <th>Paper size</th> </tr> </thead> <tbody> <tr> <td>5000</td> <td>A4</td> <td>5000</td> <td>A5R</td> </tr> <tr> <td>4300</td> <td>B5</td> <td>7800</td> <td>Folio</td> </tr> <tr> <td>5100</td> <td>11" x 8 1/2"</td> <td>10200</td> <td>11" x 17"</td> </tr> <tr> <td>10000</td> <td>A3</td> <td>9000</td> <td>11" x 15"</td> </tr> <tr> <td>8600</td> <td>B4</td> <td>8400</td> <td>8 1/2" x 14"</td> </tr> <tr> <td>7100</td> <td>A4R</td> <td>6600</td> <td>8 1/2" x 11"</td> </tr> <tr> <td>6100</td> <td>B5R</td> <td>5100</td> <td>5 1/2" x 8 1/2"</td> </tr> </tbody> </table> <ol style="list-style-type: none"> 4. Press the start key. Scanning starts under the selected conditions. 5. To stop operation, press the stop key. <p>Method: [HOME POSITION]</p> <ol style="list-style-type: none"> 1. Select [HOME POSITION]. 2. Press the start key. The mirror frame of the scanner moves to the home position. <p>Method: [DUST CHECK]</p> <ol style="list-style-type: none"> 1. Select [DUST CHECK]. 2. Press the start key. The exposure lamp lights. 3. To turn the exposure lamp off, press the stop key. <p>Method: [DP READING]</p> <ol style="list-style-type: none"> 1. Select [DP READING]. 2. Press the start key. The mirror frame of the scanner moves to the reading position. <p>Completion Press the stop key when scanning stops. The screen for selecting a maintenance item No. is displayed.</p>	Display	Description	SCANNER MOTOR	Scanner operation	HOME POSITION	Home position operation	DUST CHECK	Dust adhesion check operation with lamp on	DP READING	DP scanning position operation	Display	Operating conditions	Setting range	ZOOM	Magnification	25 to 400 %	SIZE	Original size	See below.	LAMP	On and off of the exposure lamp	0 (off) or 1 (on)	Setting	Paper size	Setting	Paper size	5000	A4	5000	A5R	4300	B5	7800	Folio	5100	11" x 8 1/2"	10200	11" x 17"	10000	A3	9000	11" x 15"	8600	B4	8400	8 1/2" x 14"	7100	A4R	6600	8 1/2" x 11"	6100	B5R	5100	5 1/2" x 8 1/2"
Display	Description																																																						
SCANNER MOTOR	Scanner operation																																																						
HOME POSITION	Home position operation																																																						
DUST CHECK	Dust adhesion check operation with lamp on																																																						
DP READING	DP scanning position operation																																																						
Display	Operating conditions	Setting range																																																					
ZOOM	Magnification	25 to 400 %																																																					
SIZE	Original size	See below.																																																					
LAMP	On and off of the exposure lamp	0 (off) or 1 (on)																																																					
Setting	Paper size	Setting	Paper size																																																				
5000	A4	5000	A5R																																																				
4300	B5	7800	Folio																																																				
5100	11" x 8 1/2"	10200	11" x 17"																																																				
10000	A3	9000	11" x 15"																																																				
8600	B4	8400	8 1/2" x 14"																																																				
7100	A4R	6600	8 1/2" x 11"																																																				
6100	B5R	5100	5 1/2" x 8 1/2"																																																				

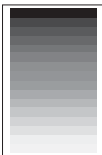
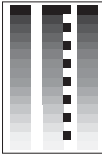
Maintenance item No.	Description								
U074	<p>Adjusting the DP input light luminosity</p> <p>Description Sets the luminosity correction for scanning originals from the DP.</p> <p>Purpose Modify the setting only if a spotted background appears when a bluish original is scanned from the DP.</p> <p>Setting</p> <ol style="list-style-type: none"> 1. Press the start key. 2. Change the setting using the +/- or numeric keys. <table border="1" data-bbox="333 535 1398 618"> <thead> <tr> <th>Display</th> <th>Description</th> <th>Setting range</th> <th>Initial setting</th> </tr> </thead> <tbody> <tr> <td>INPUT DATA</td> <td>DP input light luminosity correction</td> <td>0 to 3</td> <td>0</td> </tr> </tbody> </table> <p>Settings 0: No correction / 1: Slight correction / 2: Medium correction / 3: Strong correction</p> <ol style="list-style-type: none"> 3. Press the start key. The value is set. <p>Supplement While this maintenance item is being executed, copying from an original is available in interrupt copying mode (which is activated by pressing the system menu key).</p> <p>Completion Press the stop key. The screen for selecting a maintenance item No. is displayed.</p>	Display	Description	Setting range	Initial setting	INPUT DATA	DP input light luminosity correction	0 to 3	0
Display	Description	Setting range	Initial setting						
INPUT DATA	DP input light luminosity correction	0 to 3	0						
U080	<p>Setting the economy mode</p> <p>Description Sets the level in the economy mode.</p> <p>Purpose To increase or decrease the image density in the eco-print mode.</p> <p>Setting</p> <ol style="list-style-type: none"> 1. Press the start key. 2. Change the setting value using the +/- or numeric keys. <table border="1" data-bbox="333 1169 1398 1252"> <thead> <tr> <th>Display</th> <th>Description</th> <th>Setting range</th> <th>Initial setting</th> </tr> </thead> <tbody> <tr> <td>ECO MODE</td> <td>Exposure is toner economy mode</td> <td>0 to 100</td> <td>60</td> </tr> </tbody> </table> <p>Increasing the setting makes the image darker; decreasing it makes the image lighter.</p> <ol style="list-style-type: none"> 3. Press the start key. The value is set. <p>Supplement While this maintenance item is being executed, copying from an original is available in interrupt copying mode (which is activated by pressing the system menu key).</p> <p>Completion Press the stop key. The screen for selecting a maintenance item No. is displayed.</p>	Display	Description	Setting range	Initial setting	ECO MODE	Exposure is toner economy mode	0 to 100	60
Display	Description	Setting range	Initial setting						
ECO MODE	Exposure is toner economy mode	0 to 100	60						

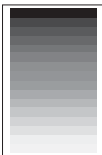
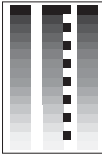
Maintenance item No.	Description																						
U081	<p>Adjusting the correct exposure</p> <p>Description Adjusts the correct exposure in text and photo mode, text mode or photo mode.</p> <p>Purpose To be executed as required.</p> <p>Setting</p> <ol style="list-style-type: none"> 1. Press the start key. 2. Select the item to be set. 3. Change the setting using the +/- or numeric keys. <table border="1" data-bbox="333 535 1398 730"> <thead> <tr> <th>Display</th> <th>Description</th> <th>Setting range</th> <th>Initial setting</th> </tr> </thead> <tbody> <tr> <td>MIX ADJ</td> <td>Adjusts the correct exposure in text and photo mode</td> <td>-3 to 3</td> <td>0</td> </tr> <tr> <td>TEXT ADJ</td> <td>Adjusts the correct exposure in text mode</td> <td>-3 to 3</td> <td>0</td> </tr> <tr> <td>PHOTO ADJ</td> <td>Adjusts the correct exposure in photo mode</td> <td>-3 to 3</td> <td>0</td> </tr> </tbody> </table> <p>Increasing the setting makes the image darker; decreasing it makes the image lighter.</p> <ol style="list-style-type: none"> 4. Press the start key. The value is set. <p>Supplement While this maintenance item is being executed, copying from an original is available in interrupt copying mode (which is activated by pressing the system menu key).</p> <p>Completion Press the stop key. The screen for selecting a maintenance item No. is displayed.</p>	Display	Description	Setting range	Initial setting	MIX ADJ	Adjusts the correct exposure in text and photo mode	-3 to 3	0	TEXT ADJ	Adjusts the correct exposure in text mode	-3 to 3	0	PHOTO ADJ	Adjusts the correct exposure in photo mode	-3 to 3	0						
Display	Description	Setting range	Initial setting																				
MIX ADJ	Adjusts the correct exposure in text and photo mode	-3 to 3	0																				
TEXT ADJ	Adjusts the correct exposure in text mode	-3 to 3	0																				
PHOTO ADJ	Adjusts the correct exposure in photo mode	-3 to 3	0																				
U087	<p>Setting DP reading position modification operation</p> <p>Description The presence or absence of dust is determined by comparing the scan data of the original trailing edge and that taken after the original is conveyed past the DP original scanning position. If dust is identified, the DP original scanning position is adjusted for the following originals.</p> <p>Purpose When using DP, to solve the problem when black lines occurs due to the dust with respect to original reading position.</p> <p>Method</p> <ol style="list-style-type: none"> 1. Press the start key. 2. Select the item to be set. The setting screen for the selected item is displayed. <table border="1" data-bbox="333 1368 1398 1496"> <thead> <tr> <th>Display</th> <th>Description</th> </tr> </thead> <tbody> <tr> <td>CCD</td> <td>Setting of standard data when dust is detected</td> </tr> <tr> <td>BLACK LINE</td> <td>Initialization of original reading position</td> </tr> </tbody> </table> <p>Setting: Standard data when dust is detected</p> <ol style="list-style-type: none"> 1. Select the item to be set. 2. Change the value using the +/- or numeric keys. <table border="1" data-bbox="333 1626 1398 1794"> <thead> <tr> <th>Display</th> <th>Description</th> <th>Setting range</th> <th>Initial setting</th> </tr> </thead> <tbody> <tr> <td>CCD R</td> <td>Lowest density of the R regard as the dust</td> <td>0 to 255</td> <td>125</td> </tr> <tr> <td>CCD G</td> <td>Lowest density of the G regard as the dust</td> <td>0 to 255</td> <td>125</td> </tr> <tr> <td>CCD B</td> <td>Lowest density of the B regard as the dust</td> <td>0 to 255</td> <td>125</td> </tr> </tbody> </table> <ol style="list-style-type: none"> 3. Press the start key. The value is set. <p>Setting: Initialization of original reading position</p> <ol style="list-style-type: none"> 1. Select [CLEAR]. 2. Press the start key. The setting is cleared. <p>Completion Press the stop key. The screen for selecting a maintenance item No. is displayed.</p>	Display	Description	CCD	Setting of standard data when dust is detected	BLACK LINE	Initialization of original reading position	Display	Description	Setting range	Initial setting	CCD R	Lowest density of the R regard as the dust	0 to 255	125	CCD G	Lowest density of the G regard as the dust	0 to 255	125	CCD B	Lowest density of the B regard as the dust	0 to 255	125
Display	Description																						
CCD	Setting of standard data when dust is detected																						
BLACK LINE	Initialization of original reading position																						
Display	Description	Setting range	Initial setting																				
CCD R	Lowest density of the R regard as the dust	0 to 255	125																				
CCD G	Lowest density of the G regard as the dust	0 to 255	125																				
CCD B	Lowest density of the B regard as the dust	0 to 255	125																				

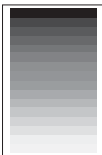
Maintenance item No.	Description															
<p>U089</p>	<p>Outputting a MIP-PG pattern</p> <p>Description Selects and outputs the MIP-PG pattern created in the machine.</p> <p>Purpose To check copier status other than scanner when adjusting image printing, using MIP-PG pattern output (with-out scanning).</p> <p>Method</p> <ol style="list-style-type: none"> 1. Press the start key. 2. Select the MIP-PG pattern to be output and press the start key. <table border="1" data-bbox="331 562 1321 1444"> <thead> <tr> <th data-bbox="338 571 598 607">Display</th> <th data-bbox="598 571 903 607">PG pattern to be output</th> <th data-bbox="903 571 1315 607">Purpose</th> </tr> </thead> <tbody> <tr> <td data-bbox="338 607 598 815">GRAYSCALE</td> <td data-bbox="598 607 903 815">  </td> <td data-bbox="903 607 1315 815">To check the laser scanner unit engine output characteristics</td> </tr> <tr> <td data-bbox="338 815 598 1023">MONO1 (Output density: 0)</td> <td data-bbox="598 815 903 1023">  </td> <td data-bbox="903 815 1315 1023">To check the drum quality</td> </tr> <tr> <td data-bbox="338 1023 598 1232">MONO4 (Output density: 70)</td> <td data-bbox="598 1023 903 1232">  </td> <td data-bbox="903 1023 1315 1232">To check the drum quality</td> </tr> <tr> <td data-bbox="338 1232 598 1440">256-LEVEL</td> <td data-bbox="598 1232 903 1440">  </td> <td data-bbox="903 1232 1315 1440">To check resolution reproducibility in printing</td> </tr> </tbody> </table> <ol style="list-style-type: none"> 3. Press the system menu key. 4. Press the start key. A MIP-PG pattern is output. <p>Completion Press the stop key. The screen for selecting a maintenance item No. is displayed.</p>	Display	PG pattern to be output	Purpose	GRAYSCALE		To check the laser scanner unit engine output characteristics	MONO1 (Output density: 0)		To check the drum quality	MONO4 (Output density: 70)		To check the drum quality	256-LEVEL		To check resolution reproducibility in printing
Display	PG pattern to be output	Purpose														
GRAYSCALE		To check the laser scanner unit engine output characteristics														
MONO1 (Output density: 0)		To check the drum quality														
MONO4 (Output density: 70)		To check the drum quality														
256-LEVEL		To check resolution reproducibility in printing														

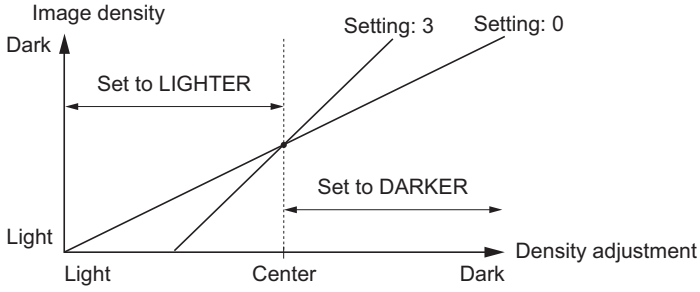
Maintenance item No.	Description																																				
<p>U093</p>	<p>Setting the exposure density gradient</p> <p>Description Changes the exposure density gradient in the manual density mode, depending on respective image quality modes.</p> <p>Purpose To set how the image density is altered by a change of one step in the manual density adjustment for respective image quality modes. Also used to make copy images darker or lighter.</p> <p>Method</p> <ol style="list-style-type: none"> 1. Press the start key. 2. Select the image quality mode. The setting screen for the selected item is displayed. <table border="1" data-bbox="331 593 1398 842"> <thead> <tr> <th>Display</th> <th>Description</th> </tr> </thead> <tbody> <tr> <td>TEXT</td> <td>Density in the text mode</td> </tr> <tr> <td>MIXED</td> <td>Density in the text and photo mode</td> </tr> <tr> <td>OTHER</td> <td>Density in modes other than the text mode or the text and photo mode</td> </tr> <tr> <td>FAX TEXT</td> <td>Density in the text in fax mode</td> </tr> <tr> <td>FAX PHOTO</td> <td>Density in the photo in fax mode</td> </tr> </tbody> </table> <p>Setting: [TEXT]</p> <ol style="list-style-type: none"> 1. Select the item to be set. 2. Adjust the setting using the +/- or numeric keys. <table border="1" data-bbox="331 976 1398 1133"> <thead> <tr> <th>Display</th> <th>Description</th> <th>Setting range</th> <th>Initial setting</th> </tr> </thead> <tbody> <tr> <td>TEXT DARKER</td> <td>Change in density when manual density is set dark</td> <td>0 to 3</td> <td>0</td> </tr> <tr> <td>TEXT LIGHTER</td> <td>Change in density when manual density is set light</td> <td>0 to 3</td> <td>0</td> </tr> </tbody> </table> <p>Increasing the setting makes the change in density larger, and decreasing it makes the change smaller.</p>  <p>Figure 1-3-16</p> <ol style="list-style-type: none"> 3. Press the start key. The value is set. <p>Setting: [MIXED]</p> <ol style="list-style-type: none"> 1. Select the item to be set. 2. Adjust the setting using the +/- or numeric keys. <table border="1" data-bbox="331 1715 1398 1872"> <thead> <tr> <th>Display</th> <th>Description</th> <th>Setting range</th> <th>Initial setting</th> </tr> </thead> <tbody> <tr> <td>MIXED DARKER</td> <td>Change in density when manual density is set dark</td> <td>0 to 3</td> <td>0</td> </tr> <tr> <td>MIXED LIGHTER</td> <td>Change in density when manual density is set light</td> <td>0 to 3</td> <td>0</td> </tr> </tbody> </table> <p>Increasing the setting makes the change in density larger, and decreasing it makes the change smaller.</p> <ol style="list-style-type: none"> 3. Press the start key. The value is set. 	Display	Description	TEXT	Density in the text mode	MIXED	Density in the text and photo mode	OTHER	Density in modes other than the text mode or the text and photo mode	FAX TEXT	Density in the text in fax mode	FAX PHOTO	Density in the photo in fax mode	Display	Description	Setting range	Initial setting	TEXT DARKER	Change in density when manual density is set dark	0 to 3	0	TEXT LIGHTER	Change in density when manual density is set light	0 to 3	0	Display	Description	Setting range	Initial setting	MIXED DARKER	Change in density when manual density is set dark	0 to 3	0	MIXED LIGHTER	Change in density when manual density is set light	0 to 3	0
Display	Description																																				
TEXT	Density in the text mode																																				
MIXED	Density in the text and photo mode																																				
OTHER	Density in modes other than the text mode or the text and photo mode																																				
FAX TEXT	Density in the text in fax mode																																				
FAX PHOTO	Density in the photo in fax mode																																				
Display	Description	Setting range	Initial setting																																		
TEXT DARKER	Change in density when manual density is set dark	0 to 3	0																																		
TEXT LIGHTER	Change in density when manual density is set light	0 to 3	0																																		
Display	Description	Setting range	Initial setting																																		
MIXED DARKER	Change in density when manual density is set dark	0 to 3	0																																		
MIXED LIGHTER	Change in density when manual density is set light	0 to 3	0																																		

Maintenance item No.	Description																																				
U093	<p>Setting: [OTHER]</p> <ol style="list-style-type: none"> Select the item to be set. Adjust the setting using the +/- or numeric keys. <table border="1" data-bbox="335 358 1398 515"> <thead> <tr> <th>Display</th> <th>Description</th> <th>Setting range</th> <th>Initial setting</th> </tr> </thead> <tbody> <tr> <td>OTHER DARKER</td> <td>Change in density when manual density is set dark</td> <td>0 to 3</td> <td>0</td> </tr> <tr> <td>OTHER LIGTER</td> <td>Change in density when manual density is set light</td> <td>0 to 3</td> <td>0</td> </tr> </tbody> </table> <p>Increasing the setting makes the change in density larger, and decreasing it makes the change smaller.</p> <ol style="list-style-type: none"> Press the start key. The value is set. <p>Setting: [FAX TEXT]</p> <ol style="list-style-type: none"> Select the item to be set. Adjust the setting using the +/- or numeric keys. <table border="1" data-bbox="335 705 1398 922"> <thead> <tr> <th>Display</th> <th>Description</th> <th>Setting range</th> <th>Initial setting</th> </tr> </thead> <tbody> <tr> <td>FAX TEXT DARKER</td> <td>Change in density when manual density is set dark</td> <td>0 to 3</td> <td>0</td> </tr> <tr> <td>FAX TEXT LIGHTER</td> <td>Change in density when manual density is set light</td> <td>0 to 3</td> <td>0</td> </tr> </tbody> </table> <p>Increasing the setting makes the change in density larger, and decreasing it makes the change smaller.</p> <ol style="list-style-type: none"> Press the start key. The value is set. <p>Setting: [FAX PHOTO]</p> <ol style="list-style-type: none"> Select the item to be set. Adjust the setting using the +/- or numeric keys. <table border="1" data-bbox="335 1115 1398 1332"> <thead> <tr> <th>Display</th> <th>Description</th> <th>Setting range</th> <th>Initial setting</th> </tr> </thead> <tbody> <tr> <td>FAX PHOTO DARKER</td> <td>Change in density when manual density is set dark</td> <td>0 to 3</td> <td>0</td> </tr> <tr> <td>FAX PHOTO LIGHTER</td> <td>Change in density when manual density is set light</td> <td>0 to 3</td> <td>0</td> </tr> </tbody> </table> <p>Increasing the setting makes the change in density larger, and decreasing it makes the change smaller.</p> <ol style="list-style-type: none"> Press the start key. The value is set. <p>Supplement</p> <p>While this maintenance item is being executed, copying from an original is available in interrupt copying mode (which is activated by pressing the system menu key).</p> <p>Completion</p> <p>Press the stop key. The screen for selecting a maintenance item No. is displayed.</p>	Display	Description	Setting range	Initial setting	OTHER DARKER	Change in density when manual density is set dark	0 to 3	0	OTHER LIGTER	Change in density when manual density is set light	0 to 3	0	Display	Description	Setting range	Initial setting	FAX TEXT DARKER	Change in density when manual density is set dark	0 to 3	0	FAX TEXT LIGHTER	Change in density when manual density is set light	0 to 3	0	Display	Description	Setting range	Initial setting	FAX PHOTO DARKER	Change in density when manual density is set dark	0 to 3	0	FAX PHOTO LIGHTER	Change in density when manual density is set light	0 to 3	0
Display	Description	Setting range	Initial setting																																		
OTHER DARKER	Change in density when manual density is set dark	0 to 3	0																																		
OTHER LIGTER	Change in density when manual density is set light	0 to 3	0																																		
Display	Description	Setting range	Initial setting																																		
FAX TEXT DARKER	Change in density when manual density is set dark	0 to 3	0																																		
FAX TEXT LIGHTER	Change in density when manual density is set light	0 to 3	0																																		
Display	Description	Setting range	Initial setting																																		
FAX PHOTO DARKER	Change in density when manual density is set dark	0 to 3	0																																		
FAX PHOTO LIGHTER	Change in density when manual density is set light	0 to 3	0																																		

Maintenance item No.	Description																																																		
U099	<p>Adjusting original size detection</p> <p>Description Checks the operation of the original size sensor and sets the sensing threshold value.</p> <p>Purpose To adjust the sensitiveness of the sensor and size judgement time if the original size sensor malfunctions frequently due to incident light or the like.</p> <p>Method</p> <ol style="list-style-type: none"> 1. Press the start key. 2. Select the item. The screen for executing each item is displayed. <table border="1" data-bbox="333 562 1396 719"> <thead> <tr> <th>Display</th> <th>Description</th> </tr> </thead> <tbody> <tr> <td>DATA1</td> <td>Displaying original size sensor transmission data</td> </tr> <tr> <td>B/W LEVEL1</td> <td>B/W LEVEL setting original size sensor threshold value Setting original size judgment time</td> </tr> </tbody> </table> <p>Method: Display the data for the sensor</p> <ol style="list-style-type: none"> 1. Place the original and close the original cover or DP. The detection sensor transmission data is displayed. <table border="1" data-bbox="333 848 1396 1097"> <thead> <tr> <th>Display</th> <th>Description</th> </tr> </thead> <tbody> <tr> <td>ORIGINAL AREA R</td> <td>Detected original width size (R)</td> </tr> <tr> <td>ORIGINAL AREA G</td> <td>Detected original width size (G)</td> </tr> <tr> <td>ORIGINAL AREA B</td> <td>Detected original width size (B)</td> </tr> <tr> <td>ORIGINAL AREA</td> <td>Detected original width size</td> </tr> <tr> <td>SIZE SW L</td> <td>Displays the original size sensor (OSS) ON/OFF</td> </tr> </tbody> </table> <ol style="list-style-type: none"> 2. To return to the screen for selecting an item, press the stop key. <p>Setting: Detection sensor threshold value</p> <ol style="list-style-type: none"> 1. Select an item to be set. 2. Adjust the setting using the +/- or numeric keys. <table border="1" data-bbox="333 1261 1396 1655"> <thead> <tr> <th>Display</th> <th>Description</th> <th>Setting range</th> <th>Initial setting</th> </tr> </thead> <tbody> <tr> <td>ORIGINAL R1 - 3</td> <td>Original threshold value for color R</td> <td>0 to 255</td> <td>40/30/20</td> </tr> <tr> <td>ORIGINAL G1 - 3</td> <td>Original threshold value for color G</td> <td>0 to 255</td> <td>40/30/20</td> </tr> <tr> <td>ORIGINAL B1 - 3</td> <td>Original threshold value for color B</td> <td>0 to 255</td> <td>40/30/20</td> </tr> <tr> <td>LIGHT SOURCE R</td> <td>Light source threshold value for color R</td> <td>0 to 255</td> <td>19</td> </tr> <tr> <td>LIGHT SOURCE G</td> <td>Light source threshold value for color G</td> <td>0 to 255</td> <td>19</td> </tr> <tr> <td>LIGHT SOURCE B</td> <td>Light source threshold value for color B</td> <td>0 to 255</td> <td>19</td> </tr> <tr> <td>WAIT TIME</td> <td>Time from activation of the original detection switch (ODSW) to original size judgment</td> <td>0 to 255</td> <td>185</td> </tr> </tbody> </table> <ol style="list-style-type: none"> 3. Press the start key. The value is set. <p>Completion Press the stop key. The screen for selecting a maintenance item No. is displayed.</p>	Display	Description	DATA1	Displaying original size sensor transmission data	B/W LEVEL1	B/W LEVEL setting original size sensor threshold value Setting original size judgment time	Display	Description	ORIGINAL AREA R	Detected original width size (R)	ORIGINAL AREA G	Detected original width size (G)	ORIGINAL AREA B	Detected original width size (B)	ORIGINAL AREA	Detected original width size	SIZE SW L	Displays the original size sensor (OSS) ON/OFF	Display	Description	Setting range	Initial setting	ORIGINAL R1 - 3	Original threshold value for color R	0 to 255	40/30/20	ORIGINAL G1 - 3	Original threshold value for color G	0 to 255	40/30/20	ORIGINAL B1 - 3	Original threshold value for color B	0 to 255	40/30/20	LIGHT SOURCE R	Light source threshold value for color R	0 to 255	19	LIGHT SOURCE G	Light source threshold value for color G	0 to 255	19	LIGHT SOURCE B	Light source threshold value for color B	0 to 255	19	WAIT TIME	Time from activation of the original detection switch (ODSW) to original size judgment	0 to 255	185
Display	Description																																																		
DATA1	Displaying original size sensor transmission data																																																		
B/W LEVEL1	B/W LEVEL setting original size sensor threshold value Setting original size judgment time																																																		
Display	Description																																																		
ORIGINAL AREA R	Detected original width size (R)																																																		
ORIGINAL AREA G	Detected original width size (G)																																																		
ORIGINAL AREA B	Detected original width size (B)																																																		
ORIGINAL AREA	Detected original width size																																																		
SIZE SW L	Displays the original size sensor (OSS) ON/OFF																																																		
Display	Description	Setting range	Initial setting																																																
ORIGINAL R1 - 3	Original threshold value for color R	0 to 255	40/30/20																																																
ORIGINAL G1 - 3	Original threshold value for color G	0 to 255	40/30/20																																																
ORIGINAL B1 - 3	Original threshold value for color B	0 to 255	40/30/20																																																
LIGHT SOURCE R	Light source threshold value for color R	0 to 255	19																																																
LIGHT SOURCE G	Light source threshold value for color G	0 to 255	19																																																
LIGHT SOURCE B	Light source threshold value for color B	0 to 255	19																																																
WAIT TIME	Time from activation of the original detection switch (ODSW) to original size judgment	0 to 255	185																																																

Maintenance item No.	Description						
U100	<p>Setting the main high voltage</p> <p>Description Performs main charging.</p> <p>Purpose To check main charging.</p> <p>Method</p> <ol style="list-style-type: none"> 1. Press the start key. 2. Select the item to be operated. 3. Press the start key. The selected operation starts. <table border="1" data-bbox="336 566 1398 689"> <thead> <tr> <th data-bbox="336 566 636 607">Display</th> <th data-bbox="636 566 1398 607">Description</th> </tr> </thead> <tbody> <tr> <td data-bbox="336 607 636 647">MC</td> <td data-bbox="636 607 1398 647">Turning the main charger on</td> </tr> <tr> <td data-bbox="336 647 636 689">LASER</td> <td data-bbox="636 647 1398 689">Turning the main charger on and the laser scanner unit on and off</td> </tr> </tbody> </table> <ol style="list-style-type: none"> 4. To stop operation, press the stop key. <p>Completion Press the stop key when main charger output stops. The screen for selecting a maintenance item No. is displayed.</p>	Display	Description	MC	Turning the main charger on	LASER	Turning the main charger on and the laser scanner unit on and off
Display	Description						
MC	Turning the main charger on						
LASER	Turning the main charger on and the laser scanner unit on and off						

Maintenance item No.	Description																																															
U101	<p>Setting the other high voltages</p> <p>Description Sets the developing bias control voltage, the transfer control voltage, and the separation control voltage or checks the output of these voltages.</p> <p>Purpose To check the developing bias, the transfer voltage and the separation voltage or to take measures against drop of image density or background fog.</p> <p>Setting</p> <ol style="list-style-type: none"> 1. Press the start key. 2. Select the item to be set. 3. Change the setting using the +/- or numeric keys. <table border="1" data-bbox="333 629 1398 1294"> <thead> <tr> <th>Display</th> <th>Description</th> <th>Setting range</th> <th>Initial setting</th> </tr> </thead> <tbody> <tr> <td>DEV BIAS</td> <td>Developing bias AC component frequency at image formation</td> <td>20 to 32</td> <td>26</td> </tr> <tr> <td>DEV SBIAS</td> <td>Developing shift bias potential at image formation</td> <td>0 to 255</td> <td>58</td> </tr> <tr> <td>DEV DUTY</td> <td>Developing bias AC component duty at image formation</td> <td>0 to 100</td> <td>50</td> </tr> <tr> <td>TC DATA</td> <td>Transfer control voltage</td> <td>0 to 255</td> <td>89</td> </tr> <tr> <td>SC DATA</td> <td>Separation control voltage</td> <td>0 to 2</td> <td>1</td> </tr> <tr> <td>TC DATA2</td> <td>Transfer control voltage for small sizes</td> <td>0 to 255</td> <td>115</td> </tr> <tr> <td>TC ON</td> <td>Time of period since the registration clutch is turned on until the transfer voltage is turned on</td> <td>0 to 255</td> <td>91</td> </tr> <tr> <td>TC OFF</td> <td>Time of period since the registration clutch is turned off until the transfer voltage is turned off</td> <td>0 to 255</td> <td>68</td> </tr> <tr> <td>SC ON</td> <td>Time of period since the registration clutch is turned on until the separation voltage is turned on</td> <td>0 to 255</td> <td>40</td> </tr> <tr> <td>SC OFF</td> <td>Time of period since the registration clutch is turned off until the separation voltage is turned off</td> <td>0 to 255</td> <td>92</td> </tr> </tbody> </table> <p>Increasing the DEV BIAS setting makes the image darker; decreasing it makes the image lighter. Increasing the DEV SBIAS setting makes the image darker. Increasing the DEV DUTY setting makes the image lighter; decreasing it makes the image darker. Increasing the TC DATA/TC DATA2 setting makes the transfer voltage higher, and decreasing it makes the voltage lower. Increasing the SC DATA setting makes the separation voltage higher, and decreasing it makes the voltage lower.</p> <ol style="list-style-type: none"> 4. Press the start key. The value is set. <p>Completion Press the stop key. The screen for selecting a maintenance item No. is displayed.</p>				Display	Description	Setting range	Initial setting	DEV BIAS	Developing bias AC component frequency at image formation	20 to 32	26	DEV SBIAS	Developing shift bias potential at image formation	0 to 255	58	DEV DUTY	Developing bias AC component duty at image formation	0 to 100	50	TC DATA	Transfer control voltage	0 to 255	89	SC DATA	Separation control voltage	0 to 2	1	TC DATA2	Transfer control voltage for small sizes	0 to 255	115	TC ON	Time of period since the registration clutch is turned on until the transfer voltage is turned on	0 to 255	91	TC OFF	Time of period since the registration clutch is turned off until the transfer voltage is turned off	0 to 255	68	SC ON	Time of period since the registration clutch is turned on until the separation voltage is turned on	0 to 255	40	SC OFF	Time of period since the registration clutch is turned off until the separation voltage is turned off	0 to 255	92
Display	Description	Setting range	Initial setting																																													
DEV BIAS	Developing bias AC component frequency at image formation	20 to 32	26																																													
DEV SBIAS	Developing shift bias potential at image formation	0 to 255	58																																													
DEV DUTY	Developing bias AC component duty at image formation	0 to 100	50																																													
TC DATA	Transfer control voltage	0 to 255	89																																													
SC DATA	Separation control voltage	0 to 2	1																																													
TC DATA2	Transfer control voltage for small sizes	0 to 255	115																																													
TC ON	Time of period since the registration clutch is turned on until the transfer voltage is turned on	0 to 255	91																																													
TC OFF	Time of period since the registration clutch is turned off until the transfer voltage is turned off	0 to 255	68																																													
SC ON	Time of period since the registration clutch is turned on until the separation voltage is turned on	0 to 255	40																																													
SC OFF	Time of period since the registration clutch is turned off until the separation voltage is turned off	0 to 255	92																																													

Maintenance item No.	Description																		
<p>U110</p>	<p>Checking the drum count Description Displays the drum counts for checking. Purpose To check the drum status. Method 1. Press the start key. The drum counter count is displayed. Completion Press the stop key. The screen for selecting a maintenance item No. is displayed.</p>																		
<p>U114</p>	<p>Setting separation charger mode Description Sets the separation charger mode. Purpose To change the setting if the fuser offset or carrier leaking occurs. Method 1. Press the start key. 2. Change the setting using the +/- or numeric keys.</p> <table border="1" data-bbox="333 869 1398 949"> <thead> <tr> <th>Display</th> <th>Description</th> <th>Setting range</th> <th>Initial setting</th> </tr> </thead> <tbody> <tr> <td>MODE</td> <td>Separation charger mode</td> <td>0 to 8 (0 to 3)*</td> <td>3</td> </tr> </tbody> </table> <p>*: Entering a value other than 0 to 3 will engage the MODE3 (value 3) separation mode.</p> <p>Details on the modes</p> <table border="1" data-bbox="333 1061 1398 1460"> <thead> <tr> <th>Display</th> <th>Description</th> </tr> </thead> <tbody> <tr> <td>MODE0 (Value 0)</td> <td>Full page separation for both first and second pages</td> </tr> <tr> <td>MODE1 (Value 1)</td> <td>First page: Separation on leading and trailing edges Second page: Full page separation</td> </tr> <tr> <td>MODE2 (Value 2)</td> <td>Full page separation is activated for both first and second pages provided the ambient temperature is less than 19°C/66.2°F. First page: Separation is activated for both leading and trailing edges, second page: Full page separation, provided the ambient temperature is more than 20°C/68°F.</td> </tr> <tr> <td>MODE3 (Value 3)</td> <td>Separation is activated on both leading and trailing edges for both first and second pages</td> </tr> </tbody> </table> <p>3. Press the start key. The setting is set.</p> <p>Completion Press the stop key. The screen for selecting a maintenance item No. is displayed.</p>	Display	Description	Setting range	Initial setting	MODE	Separation charger mode	0 to 8 (0 to 3)*	3	Display	Description	MODE0 (Value 0)	Full page separation for both first and second pages	MODE1 (Value 1)	First page: Separation on leading and trailing edges Second page: Full page separation	MODE2 (Value 2)	Full page separation is activated for both first and second pages provided the ambient temperature is less than 19°C/66.2°F. First page: Separation is activated for both leading and trailing edges, second page: Full page separation, provided the ambient temperature is more than 20°C/68°F.	MODE3 (Value 3)	Separation is activated on both leading and trailing edges for both first and second pages
Display	Description	Setting range	Initial setting																
MODE	Separation charger mode	0 to 8 (0 to 3)*	3																
Display	Description																		
MODE0 (Value 0)	Full page separation for both first and second pages																		
MODE1 (Value 1)	First page: Separation on leading and trailing edges Second page: Full page separation																		
MODE2 (Value 2)	Full page separation is activated for both first and second pages provided the ambient temperature is less than 19°C/66.2°F. First page: Separation is activated for both leading and trailing edges, second page: Full page separation, provided the ambient temperature is more than 20°C/68°F.																		
MODE3 (Value 3)	Separation is activated on both leading and trailing edges for both first and second pages																		

Maintenance item No.	Description						
U117	<p>Checking the drum number</p> <p>Description Displays the drum number.</p> <p>Purpose To check the drum number.</p> <p>Method 1. Press the start key. The drum number is displayed.</p> <p>Completion Press the stop key. The screen for selecting a maintenance item No. is displayed.</p>						
U118	<p>Displaying the drum history</p> <p>Description Displays the past record of machine number and the drum counter.</p> <p>Purpose To check the count value of machine number and the drum counter.</p> <p>Method 1. Press the start key. Past record of 5 cases is displayed.</p> <table border="1" data-bbox="333 837 1398 965"> <thead> <tr> <th>Display</th> <th>Description</th> </tr> </thead> <tbody> <tr> <td>MACHINE No.1 to 5</td> <td>Past record of machine number</td> </tr> <tr> <td>COUNT 1 to 5</td> <td>Past record of drum counter</td> </tr> </tbody> </table> <p>Completion Press the stop key. The screen for selecting a maintenance item No. is displayed.</p>	Display	Description	MACHINE No.1 to 5	Past record of machine number	COUNT 1 to 5	Past record of drum counter
Display	Description						
MACHINE No.1 to 5	Past record of machine number						
COUNT 1 to 5	Past record of drum counter						
U130	<p>Initial setting for the developing unit</p> <p>Description Replenishes toner to the developing unit to a certain level from the toner container that has been installed.</p> <p>Purpose To operate when installing the machine or replacing the developing unit.</p> <p>Method 1. Press the start key. The screen for executing is displayed. 2. Press the start key. Toner installation is started and the output value of the sensor and execution time are displayed.</p> <table border="1" data-bbox="333 1370 1398 1498"> <thead> <tr> <th>Display</th> <th>Description</th> </tr> </thead> <tbody> <tr> <td>TONER SENSOR</td> <td>Output value of the sensor</td> </tr> <tr> <td>TIME(SEC)</td> <td>Execution time</td> </tr> </tbody> </table> <p>Completion Press the stop key after initial setting is complete. The screen for selecting a maintenance item No. is displayed.</p>	Display	Description	TONER SENSOR	Output value of the sensor	TIME(SEC)	Execution time
Display	Description						
TONER SENSOR	Output value of the sensor						
TIME(SEC)	Execution time						

Maintenance item No.	Description																								
<p>U135</p>	<p>Checking toner motor operation</p> <p>Description Turns the toner feed motor and toner feed clutch on.</p> <p>Purpose To check the operation of the toner feed motor or toner feed clutch. Settings may also be modified where mobility in toner is inferior or when printing materials of very high density. Normally no change is necessary from the initial setting.</p> <p>Method</p> <ol style="list-style-type: none"> 1. Press the start key. 2. Select the item. <table border="1" data-bbox="331 593 1398 873"> <thead> <tr> <th>Display</th> <th>Description</th> <th>Setting range</th> <th>Initial setting</th> </tr> </thead> <tbody> <tr> <td>TONER CARRY</td> <td>Toner feed motor (TFM)</td> <td>-</td> <td>-</td> </tr> <tr> <td>TONER SUPPLY</td> <td>Toner feed clutch (TNFCL)</td> <td>-</td> <td>-</td> </tr> <tr> <td>CARRY ON TIME</td> <td>Toner feed motor drive on time</td> <td>0 to 255</td> <td>100</td> </tr> <tr> <td>SUPPLY ON TIME</td> <td>Toner feed clutch on time</td> <td>0 to 255</td> <td>30</td> </tr> <tr> <td>SUPPLY OFF TIME</td> <td>Toner feed clutch off time</td> <td>0 to 255</td> <td>100</td> </tr> </tbody> </table> <p>Method</p> <ol style="list-style-type: none"> 1. Select [TONER CARRY] or [TONER SUPPLY]. 2. Press the start key. The operation starts. 3. To stop operation, press the stop key. <p>Setting: Low toner mobility</p> <ol style="list-style-type: none"> 1. Select [CARRY ON TIME]. 2. Increasing the setting value using the + key. 3. Press the start key. The value is set. <p>Setting: Printing very high density materials</p> <ol style="list-style-type: none"> 1. Select [SUPPLY ON TIME]. 2. Increasing the setting value using the + key. 3. Press the start key. The value is set. <p>Completion Press the stop key. The screen for selecting a maintenance item No. is displayed.</p>	Display	Description	Setting range	Initial setting	TONER CARRY	Toner feed motor (TFM)	-	-	TONER SUPPLY	Toner feed clutch (TNFCL)	-	-	CARRY ON TIME	Toner feed motor drive on time	0 to 255	100	SUPPLY ON TIME	Toner feed clutch on time	0 to 255	30	SUPPLY OFF TIME	Toner feed clutch off time	0 to 255	100
Display	Description	Setting range	Initial setting																						
TONER CARRY	Toner feed motor (TFM)	-	-																						
TONER SUPPLY	Toner feed clutch (TNFCL)	-	-																						
CARRY ON TIME	Toner feed motor drive on time	0 to 255	100																						
SUPPLY ON TIME	Toner feed clutch on time	0 to 255	30																						
SUPPLY OFF TIME	Toner feed clutch off time	0 to 255	100																						

Maintenance item No.	Description																
<p>U136</p>	<p>Setting toner near end mode</p> <p>Description Sets whether to restrict printing operation when the toner is empty.</p> <p>Purpose To set to ON to remove restrictions on printing operation when toner empty is detected.</p> <p>Setting</p> <ol style="list-style-type: none"> 1. Press the start key. 2. Select [ON] or [OFF]. <table border="1" data-bbox="333 533 1398 660"> <thead> <tr> <th>Display</th> <th>Description</th> </tr> </thead> <tbody> <tr> <td>ON</td> <td>Do not display an error or restrict printing operation when the toner is empty</td> </tr> <tr> <td>OFF</td> <td>Display an error and restrict printing operation when the toner is empty</td> </tr> </tbody> </table> <p>Initial setting: OFF</p> <ol style="list-style-type: none"> 3. Press the start key. The setting is set. <p>Completion Press the stop key. The screen for selecting a maintenance item No. is displayed.</p>	Display	Description	ON	Do not display an error or restrict printing operation when the toner is empty	OFF	Display an error and restrict printing operation when the toner is empty										
Display	Description																
ON	Do not display an error or restrict printing operation when the toner is empty																
OFF	Display an error and restrict printing operation when the toner is empty																
<p>U144</p>	<p>Setting toner loading operation</p> <p>Description Sets toner loading operation after completion of copying. Toner is forcibly evacuated in case the average printing ratio for the number of printed pages assigned by [PAGE] is lower than the ratio defined by [RATIO].</p> <p>Purpose To set whether or not toner is loaded on the drum after low density copying. Normally no change is necessary from the initial setting.</p> <p>Setting</p> <ol style="list-style-type: none"> 1. Press the start key. 2. Select the item to be set. 3. Change the setting using the +/- keys. <table border="1" data-bbox="333 1182 1398 1350"> <thead> <tr> <th>Display</th> <th>Description</th> <th>Setting range</th> <th>Initial setting</th> </tr> </thead> <tbody> <tr> <td>MODE</td> <td>Toner loading operation</td> <td>1 (ON) / 0 (OFF)</td> <td>0</td> </tr> <tr> <td>PAGE</td> <td>Number of pages set</td> <td>1 to 50</td> <td>5</td> </tr> <tr> <td>RATIO</td> <td>Printing ratio</td> <td>10 to 40</td> <td>30</td> </tr> </tbody> </table> <ol style="list-style-type: none"> 4. Press the start key. The value is set. <p>Completion Press the stop key. The screen for selecting a maintenance item No. is displayed.</p>	Display	Description	Setting range	Initial setting	MODE	Toner loading operation	1 (ON) / 0 (OFF)	0	PAGE	Number of pages set	1 to 50	5	RATIO	Printing ratio	10 to 40	30
Display	Description	Setting range	Initial setting														
MODE	Toner loading operation	1 (ON) / 0 (OFF)	0														
PAGE	Number of pages set	1 to 50	5														
RATIO	Printing ratio	10 to 40	30														

Maintenance item No.	Description												
<p>U155</p>	<p>Checking sensors for toner</p> <p>Description Displays the on-off status of each sensor or switch related to toner.</p> <p>Purpose To check if the sensors and switches operate correctly.</p> <p>Method</p> <ol style="list-style-type: none"> 1. Press the start key. 2. Turn each switch on and off manually to check the status. When the on-status of a switch is detected, that switch is displayed in reverse. <table border="1" data-bbox="333 564 1398 844"> <thead> <tr> <th data-bbox="339 573 715 607">Display</th> <th data-bbox="715 573 1391 607">Switches and sensors</th> </tr> </thead> <tbody> <tr> <td data-bbox="339 607 715 640">DEVELOPER SENSOR</td> <td data-bbox="715 607 1391 640">Toner sensor (TNS)</td> </tr> <tr> <td data-bbox="339 640 715 674">CONTAINER SET</td> <td data-bbox="715 640 1391 674">Toner container detection switch (TCDSW)</td> </tr> <tr> <td data-bbox="339 674 715 707">CONTAINER SENSOR</td> <td data-bbox="715 674 1391 707">Toner container sensor (TCS)</td> </tr> <tr> <td data-bbox="339 707 715 741">DISPOSAL TANK SENSOR</td> <td data-bbox="715 707 1391 741">Overflow sensor (OFS)</td> </tr> <tr> <td data-bbox="339 741 715 835">MOTOR</td> <td data-bbox="715 741 1391 835">The toner feed clutch (TFCL) and the paper feed motor (PFM) are turned on.</td> </tr> </tbody> </table> <ol style="list-style-type: none"> 3. To stop motor driving, press [MOTOR ON] again. <p>Completion Press the stop key. The screen for selecting a maintenance item No. is displayed.</p>	Display	Switches and sensors	DEVELOPER SENSOR	Toner sensor (TNS)	CONTAINER SET	Toner container detection switch (TCDSW)	CONTAINER SENSOR	Toner container sensor (TCS)	DISPOSAL TANK SENSOR	Overflow sensor (OFS)	MOTOR	The toner feed clutch (TFCL) and the paper feed motor (PFM) are turned on.
Display	Switches and sensors												
DEVELOPER SENSOR	Toner sensor (TNS)												
CONTAINER SET	Toner container detection switch (TCDSW)												
CONTAINER SENSOR	Toner container sensor (TCS)												
DISPOSAL TANK SENSOR	Overflow sensor (OFS)												
MOTOR	The toner feed clutch (TFCL) and the paper feed motor (PFM) are turned on.												
<p>U157</p>	<p>Checking the developing drive time</p> <p>Description Displays the developing drive time for checking, which is used as a reference when correcting the toner control.</p> <p>Purpose To check the developing drive time after replacing the developing unit.</p> <p>Method</p> <ol style="list-style-type: none"> 1. Press the start key. The developing drive time is displayed in minutes. <p>Completion Press the stop key. The screen for selecting a maintenance item No. is displayed.</p>												
<p>U158</p>	<p>Checking the developing count</p> <p>Description Displays the developing count for checking.</p> <p>Purpose To check the developing count after replacing the developing unit.</p> <p>Method</p> <ol style="list-style-type: none"> 1. Press the start key. The developing counter count is displayed. <p>Completion Press the stop key. The screen for selecting a maintenance item No. is displayed.</p>												

Maintenance item No.	Description																								
U161	<p>Setting the fuser control temperature</p> <p>Description Changes the fuser control temperature.</p> <p>Purpose Normally no change is necessary. However, can be used to prevent curling or creasing of paper, or solve a fuser problem on thick paper.</p> <p>Method</p> <ol style="list-style-type: none"> 1. Press the start key. 2. Select the item to be set. 3. Change the setting using the +/- or numeric keys. <table border="1" data-bbox="333 593 1398 981"> <thead> <tr> <th>Display</th> <th>Description</th> <th>Setting range</th> <th>Initial setting</th> </tr> </thead> <tbody> <tr> <td>DRIVE START TEMP</td> <td>Driving start temperature when warm-up starts</td> <td>0 to 255 (°C)</td> <td>110</td> </tr> <tr> <td>READY CONTROL T</td> <td>Fuser center control temperature for displaying [Ready for copying.]</td> <td>0 to 255 (°C)</td> <td>165</td> </tr> <tr> <td>READY CONTROL T2</td> <td>Fuser edge control temperature for displaying [Ready for copying.]</td> <td>0 to 255 (°C)</td> <td>155</td> </tr> <tr> <td>PRINT CONTROL T</td> <td>Fuser center control temperature during printing</td> <td>0 to 255 (°C)</td> <td>165</td> </tr> <tr> <td>READY DISP TIME</td> <td>Time of period from driving until Ready is displayed</td> <td>0 to 255 (s)</td> <td>0</td> </tr> </tbody> </table> <ol style="list-style-type: none"> 4. Press the start key. The value is set. <p>Completion Press the stop key. The screen for selecting a maintenance item No. is displayed.</p>	Display	Description	Setting range	Initial setting	DRIVE START TEMP	Driving start temperature when warm-up starts	0 to 255 (°C)	110	READY CONTROL T	Fuser center control temperature for displaying [Ready for copying.]	0 to 255 (°C)	165	READY CONTROL T2	Fuser edge control temperature for displaying [Ready for copying.]	0 to 255 (°C)	155	PRINT CONTROL T	Fuser center control temperature during printing	0 to 255 (°C)	165	READY DISP TIME	Time of period from driving until Ready is displayed	0 to 255 (s)	0
Display	Description	Setting range	Initial setting																						
DRIVE START TEMP	Driving start temperature when warm-up starts	0 to 255 (°C)	110																						
READY CONTROL T	Fuser center control temperature for displaying [Ready for copying.]	0 to 255 (°C)	165																						
READY CONTROL T2	Fuser edge control temperature for displaying [Ready for copying.]	0 to 255 (°C)	155																						
PRINT CONTROL T	Fuser center control temperature during printing	0 to 255 (°C)	165																						
READY DISP TIME	Time of period from driving until Ready is displayed	0 to 255 (s)	0																						
U163	<p>Resetting the fuser problem data</p> <p>Description Resets the detection of a service call code indicating a problem in the fuser section.</p> <p>Purpose To prevent accidents due to an abnormally high fuser temperature.</p> <p>Method</p> <ol style="list-style-type: none"> 1. Press the start key. 2. Press [EXECUTE] on the touch panel. 3. Press the start key. The fuser problem data is initialized. 4. Turn the main power switch off and on. 																								

Maintenance item No.	Description						
<p>U167</p>	<p>Checking/clearing the fuser counts Description Displays and clears the fuser counts for checking. Purpose To check the fuser count after replacement of the fuser unit. Also to clear the counts after replacing unit. Method 1. Press the start key. The fuser counts is displayed. Clearing 1. Select [CLEAR]. 2. Press the start key. The count is cleared. Setting 1. Change the count using the +/- or numeric keys. 2. Press the start key. The count is set. Completion Press the stop key. The screen for selecting a maintenance item No. is displayed.</p>						
<p>U193</p>	<p>Setting the fuser drive control Description Specifies ON/OFF the fuser drive control. Purpose Countermeasure against black dots which is caused by toner adhering to the heat roller separation claws. Setting 1. Press the start key. 2. Select ON or OFF.</p> <table border="1" data-bbox="333 1099 1398 1227"> <thead> <tr> <th>Display</th> <th>Description</th> </tr> </thead> <tbody> <tr> <td>ON</td> <td>Fuser drive control ON</td> </tr> <tr> <td>OFF</td> <td>Fuser drive control OFF</td> </tr> </tbody> </table> <p>Initial setting: ON 3. Press the start key. The setting is set. Completion Press the stop key. The screen for selecting a maintenance item No. is displayed.</p>	Display	Description	ON	Fuser drive control ON	OFF	Fuser drive control OFF
Display	Description						
ON	Fuser drive control ON						
OFF	Fuser drive control OFF						

Maintenance item No.	Description										
U198	<p>Setting the fuser phase control</p> <p>Description Enables or disables fuser-phase control.</p> <p>Purpose Turn to OFF to reduce the audible sound that may be generated by the power source PWB. Depending on the environment of installation, this may cause a voltage drop, potentially resulting in flickering fluorescent tubes, etc.</p> <p>Setting</p> <ol style="list-style-type: none"> 1. Press the start key. 2. Select ON or OFF using the cursor up/down keys. <table border="1" data-bbox="331 593 1396 719"> <thead> <tr> <th>Display</th> <th>Description</th> </tr> </thead> <tbody> <tr> <td>ON</td> <td>Fuser phase control present</td> </tr> <tr> <td>OFF</td> <td>Fuser phase control absent</td> </tr> </tbody> </table> <p>Initial setting: ON</p> <ol style="list-style-type: none"> 3. Press the start key. The setting is set. <p>Completion Press the stop/clear key. The screen for selecting a maintenance item No. is displayed.</p>	Display	Description	ON	Fuser phase control present	OFF	Fuser phase control absent				
Display	Description										
ON	Fuser phase control present										
OFF	Fuser phase control absent										
U199	<p>Checking the fuser temperature</p> <p>Description Displays the fuser temperature, the external temperature and the absolute humidity.</p> <p>Purpose To check the fuser temperature, the external temperature and the absolute humidity.</p> <p>Method</p> <ol style="list-style-type: none"> 1. Press the start key. The fuser temperature (°C/°F), external temperature (°C/°F) and the absolute humidity (%) are displayed. <table border="1" data-bbox="331 1153 1396 1361"> <thead> <tr> <th>Display</th> <th>Description</th> </tr> </thead> <tbody> <tr> <td>FIX CENTER TEMP</td> <td>Fuser center temperature (°C/°F)</td> </tr> <tr> <td>FIX EDGE TEMP</td> <td>Fuser edge temperature (°C/°F)</td> </tr> <tr> <td>SURROUND TEMP</td> <td>External temperature (°C/°F)</td> </tr> <tr> <td>HUMIDITY</td> <td>Absolute humidity (%)</td> </tr> </tbody> </table> <p>Completion Press the stop key. The screen for selecting a maintenance item No. is displayed.</p>	Display	Description	FIX CENTER TEMP	Fuser center temperature (°C/°F)	FIX EDGE TEMP	Fuser edge temperature (°C/°F)	SURROUND TEMP	External temperature (°C/°F)	HUMIDITY	Absolute humidity (%)
Display	Description										
FIX CENTER TEMP	Fuser center temperature (°C/°F)										
FIX EDGE TEMP	Fuser edge temperature (°C/°F)										
SURROUND TEMP	External temperature (°C/°F)										
HUMIDITY	Absolute humidity (%)										
U200	<p>Turning all LEDs on</p> <p>Description Turns all the LEDs on the operation panel on.</p> <p>Purpose To check if all the LEDs on the operation panel light.</p> <p>Method</p> <ol style="list-style-type: none"> 1. Press the start key. All the LEDs on the operation panel light. 2. Press the stop key. The LEDs turns off. <p>Completion Press the stop key. The screen for selecting a maintenance item No. is displayed.</p>										

Maintenance item No.	Description						
<p>U201</p>	<p>Initializing the touch panel</p> <p>Description Automatically correct the positions of the X- and Y-axes of the touch panel.</p> <p>Purpose To automatically correct the display positions on the touch panel after it is replaced.</p> <p>Method</p> <ol style="list-style-type: none"> 1. Press the start key. 2. Select the [INITIALIZE] or [CHECK]. <table border="1" data-bbox="333 535 1398 660"> <thead> <tr> <th data-bbox="336 539 636 577">Display</th> <th data-bbox="636 539 1394 577">Description</th> </tr> </thead> <tbody> <tr> <td data-bbox="336 577 636 616">INITIALIZE</td> <td data-bbox="636 577 1394 616">Adjusts the display on the panel automatically.</td> </tr> <tr> <td data-bbox="336 616 636 654">CHECK</td> <td data-bbox="636 616 1394 654">Checks the display on the touch panel.</td> </tr> </tbody> </table> <p>Method: [INITIALIZE]</p> <ol style="list-style-type: none"> 1. Press the start key. 2. Press the center of the + keys. Be sure to press three + keys displayed in order. The touch panel is adjusted automatically. 3. Press the indicated three + keys, and then check the display. 4. Press the stop key. The screen for selecting a maintenance item No. is displayed. <p>Method: [CHECK]</p> <ol style="list-style-type: none"> 1. Press the start key. 2. Press the indicated three + keys, and then check the display. When adjusting the display, press [INITIALIZE] to execute the adjustment automatically. 3. Press the stop key. The screen for selecting a maintenance item No. is displayed. <p>Completion Press the stop key. The screen for selecting a maintenance item No. is displayed.</p>	Display	Description	INITIALIZE	Adjusts the display on the panel automatically.	CHECK	Checks the display on the touch panel.
Display	Description						
INITIALIZE	Adjusts the display on the panel automatically.						
CHECK	Checks the display on the touch panel.						
<p>U202</p>	<p>Setting the KMAS host monitoring system</p> <p>Description Initializes or operates the KMAS host monitoring system. This is an optional device which is currently supported only by Japanese specification machines, so no setting is necessary.</p>						

Maintenance item No.	Description																								
U203	<p>Checking DP operation</p> <p>Description Simulates the original conveying operation separately in the DP.</p> <p>Purpose To check the DP operation.</p> <p>Method</p> <ol style="list-style-type: none"> 1. Press the start key. 2. Place an original in the DP if running this simulation with paper. 3. Select the item to be operated. <table border="1" data-bbox="333 564 1398 902"> <thead> <tr> <th>Display</th> <th>Description</th> <th>Setting range</th> <th>Initial setting</th> </tr> </thead> <tbody> <tr> <td>CCD ADP (NON P)</td> <td>Without paper, single-sided original (continuous operation)</td> <td>-</td> <td>-</td> </tr> <tr> <td>CCD ADP</td> <td>With paper, single-sided original</td> <td>-</td> <td>-</td> </tr> <tr> <td>CCD RADP (NON P)</td> <td>Without paper, double-sided original (continuous operation)</td> <td>-</td> <td>-</td> </tr> <tr> <td>CCD RADP</td> <td>With paper, double-sided original</td> <td>-</td> <td>-</td> </tr> <tr> <td>SPEED</td> <td>Switching between normal reading (600 dpi) and high-speed reading</td> <td>0 (Normal)/ 1 (High-speed)</td> <td>0</td> </tr> </tbody> </table> <ol style="list-style-type: none"> 4. Press the start key. The operation starts. 5. To stop continuous operation, press the stop key. <p>Completion Press the stop key. The screen for selecting a maintenance item No. is displayed.</p>	Display	Description	Setting range	Initial setting	CCD ADP (NON P)	Without paper, single-sided original (continuous operation)	-	-	CCD ADP	With paper, single-sided original	-	-	CCD RADP (NON P)	Without paper, double-sided original (continuous operation)	-	-	CCD RADP	With paper, double-sided original	-	-	SPEED	Switching between normal reading (600 dpi) and high-speed reading	0 (Normal)/ 1 (High-speed)	0
Display	Description	Setting range	Initial setting																						
CCD ADP (NON P)	Without paper, single-sided original (continuous operation)	-	-																						
CCD ADP	With paper, single-sided original	-	-																						
CCD RADP (NON P)	Without paper, double-sided original (continuous operation)	-	-																						
CCD RADP	With paper, double-sided original	-	-																						
SPEED	Switching between normal reading (600 dpi) and high-speed reading	0 (Normal)/ 1 (High-speed)	0																						
U204	<p>Setting the presence or absence of a key card or key counter</p> <p>Description Sets the presence or absence of the optional key card or key counter.</p> <p>Purpose To run this maintenance item if a key card or key counter is installed.</p> <p>Method</p> <ol style="list-style-type: none"> 1. Press the start key. 2. Select the item to be set. The setting screen for the selected item is displayed. <table border="1" data-bbox="333 1337 1398 1460"> <thead> <tr> <th>Display</th> <th>Description</th> </tr> </thead> <tbody> <tr> <td>KEY-DEVICE</td> <td>Sets the presence or absence of the key card or key counter</td> </tr> <tr> <td>MESSAGE</td> <td>Sets the message when optional equipment is not installed</td> </tr> </tbody> </table> <p>Setting: [KEY-DEVICE]</p> <ol style="list-style-type: none"> 1. Select the optional counter to be installed. <table border="1" data-bbox="333 1563 1398 1727"> <thead> <tr> <th>Display</th> <th>Description</th> </tr> </thead> <tbody> <tr> <td>KEY-CARD</td> <td>The key card is installed</td> </tr> <tr> <td>KEY-COUNTER</td> <td>The key counter is installed</td> </tr> <tr> <td>OFF</td> <td>Not installed</td> </tr> </tbody> </table> <p>Initial setting: OFF</p> <ol style="list-style-type: none"> 2. Press the start key. The setting is set. 3. Turn the main power switch off and on. <p>Setting: [MESSAGE]</p> <ol style="list-style-type: none"> 1. Select the [KEY-DEVICE] or [COIN VENDOR]. 2. Press the start key. The setting is set. 3. Turn the main power switch off and on. 	Display	Description	KEY-DEVICE	Sets the presence or absence of the key card or key counter	MESSAGE	Sets the message when optional equipment is not installed	Display	Description	KEY-CARD	The key card is installed	KEY-COUNTER	The key counter is installed	OFF	Not installed										
Display	Description																								
KEY-DEVICE	Sets the presence or absence of the key card or key counter																								
MESSAGE	Sets the message when optional equipment is not installed																								
Display	Description																								
KEY-CARD	The key card is installed																								
KEY-COUNTER	The key counter is installed																								
OFF	Not installed																								

Maintenance item No.	Description										
U206	<p>Setting the presence or absence of the coin vender</p> <p>Description Sets the presence or absence of the optional coin vender. Also sets the details for coin vender operation, such as mode and unit price. This is an optional device which is currently supported only by Japanese specification machines, so no setting is necessary.</p>										
U207	<p>Checking the operation panel keys</p> <p>Description Checks operation of the operation panel keys.</p> <p>Purpose To check operation of all the keys and LEDs on the operation panel.</p> <p>Method</p> <ol style="list-style-type: none"> 1. Press the start key. The screen for executing is displayed. 2. COUNT0 is displayed and the leftmost LED on the operation panel lights. 3. As the keys lined up in the same line as the lit indicator are pressed in the order from the top to the bottom, the figure shown on the touch panel increases in increments of 1. When all the keys in that line are pressed and if there are any LEDs corresponding to the keys in the line on the immediate right, the top LED in that line will light. 4. When all the keys on the operation panel have been pressed, all the LEDs light for up to 10 seconds. <p>Completion Press the stop key. The screen for selecting a maintenance item No. is displayed.</p>										
U221	<p>Setting the USB host lock function</p> <p>Description Specifies ON/OFF the USB host lock function. Setting this to ON causes the machine to be unable to recognize the device connected to the USB host.</p> <p>Purpose Set according to the preference of the user.</p> <p>Method</p> <ol style="list-style-type: none"> 1. Press the start key. 2. Select the item. <table border="1" data-bbox="336 1290 1398 1373"> <thead> <tr> <th data-bbox="336 1290 636 1330">Display</th> <th data-bbox="636 1290 1398 1330">Description</th> </tr> </thead> <tbody> <tr> <td data-bbox="336 1330 636 1373">USB HOST LOCK</td> <td data-bbox="636 1330 1398 1373">USB host lock function ON/OFF setting</td> </tr> </tbody> </table> <p>Setting</p> <ol style="list-style-type: none"> 1. Select [ON] or [OFF]. <table border="1" data-bbox="336 1476 1398 1601"> <thead> <tr> <th data-bbox="336 1476 636 1516">Display</th> <th data-bbox="636 1476 1398 1516">Description</th> </tr> </thead> <tbody> <tr> <td data-bbox="336 1516 636 1556">ON</td> <td data-bbox="636 1516 1398 1556">USB host lock function ON</td> </tr> <tr> <td data-bbox="336 1556 636 1601">OFF</td> <td data-bbox="636 1556 1398 1601">USB host lock function OFF</td> </tr> </tbody> </table> <p>Initial setting: OFF</p> <ol style="list-style-type: none"> 2. Press the start key. The setting is set. 3. Turn the main power switch off and on. 	Display	Description	USB HOST LOCK	USB host lock function ON/OFF setting	Display	Description	ON	USB host lock function ON	OFF	USB host lock function OFF
Display	Description										
USB HOST LOCK	USB host lock function ON/OFF setting										
Display	Description										
ON	USB host lock function ON										
OFF	USB host lock function OFF										
U222	<p>Setting the IC card type</p> <p>Description Sets the IC card type. This is an optional device which is currently supported only by Japanese specification machines, so no setting is necessary.</p>										

Maintenance item No.	Description																
U223	<p>Operation panel lock</p> <p>Description Sets the operation panel lock function to ON or OFF.</p> <p>Purpose To restrict operation in the system menu on the operation panel.</p> <p>Setting</p> <ol style="list-style-type: none"> 1. Press the start key. 2. Select the item. <table border="1" data-bbox="335 533 1398 701"> <thead> <tr> <th>Display</th> <th>Description</th> </tr> </thead> <tbody> <tr> <td>Unlock</td> <td>Release the lock of the operation from the system menu.</td> </tr> <tr> <td>Partial Lock</td> <td>Partially lock the operation from the system menu.</td> </tr> <tr> <td>Lock</td> <td>Entirely lock the operation from the system menu.</td> </tr> </tbody> </table> <p>Initial setting: Unlock</p> <ol style="list-style-type: none"> 3. Press the start key. The setting is set. <p>Completion Press the stop key. The screen for selecting a maintenance item No. is displayed.</p>	Display	Description	Unlock	Release the lock of the operation from the system menu.	Partial Lock	Partially lock the operation from the system menu.	Lock	Entirely lock the operation from the system menu.								
Display	Description																
Unlock	Release the lock of the operation from the system menu.																
Partial Lock	Partially lock the operation from the system menu.																
Lock	Entirely lock the operation from the system menu.																
U224	<p>Panel sheet extension</p> <p>Description Changes the image data and the message of the opening screen at the machine startup and the image data and the message of the service call screen to user specified data.</p> <p>Purpose Set according to the preference of the user.</p> <p>Setting</p> <ol style="list-style-type: none"> 1. Write the image data or the message data to the USB memory. 2. Insert USB memory in USB memory slot of the machine. 3. Turn the main power switch on. 4. Enter the maintenance item. 5. Press the start key. 6. Select the [Install] or [UnInstall]. <table border="1" data-bbox="335 1279 1398 1406"> <thead> <tr> <th>Display</th> <th>Description</th> </tr> </thead> <tbody> <tr> <td>Install</td> <td>Installs the image data or the message data</td> </tr> <tr> <td>UnInstall</td> <td>Restores the original image data or message data</td> </tr> </tbody> </table> <ol style="list-style-type: none"> 7. Select the item. <table border="1" data-bbox="335 1451 1398 1659"> <thead> <tr> <th>Display</th> <th>Description</th> </tr> </thead> <tbody> <tr> <td>Opening Img</td> <td>Startup screen</td> </tr> <tr> <td>Call Img</td> <td>Service call image</td> </tr> <tr> <td>Call Msg Top</td> <td>Service call screen 1</td> </tr> <tr> <td>Call Msg Detail</td> <td>Service call screen 2</td> </tr> </tbody> </table> <ol style="list-style-type: none"> 8. Press the start key. Installation or uninstallation is started. 9. When normally completed, [COMPLETE] is displayed. <p>Completion Press the stop key. The screen for selecting a maintenance item No. is displayed.</p>	Display	Description	Install	Installs the image data or the message data	UnInstall	Restores the original image data or message data	Display	Description	Opening Img	Startup screen	Call Img	Service call image	Call Msg Top	Service call screen 1	Call Msg Detail	Service call screen 2
Display	Description																
Install	Installs the image data or the message data																
UnInstall	Restores the original image data or message data																
Display	Description																
Opening Img	Startup screen																
Call Img	Service call image																
Call Msg Top	Service call screen 1																
Call Msg Detail	Service call screen 2																

Maintenance item No.	Description								
<p>U233</p>	<p>Limiting job separator output</p> <p>Description Sets a limit of number of output pages from the job separator.</p> <p>Purpose Settings may be modified if curled paper is output from the job separator.</p> <p>Setting</p> <ol style="list-style-type: none"> 1. Press the start key. 2. Select the mode. <table border="1" data-bbox="333 533 1398 701"> <thead> <tr> <th>Display</th> <th>Description</th> </tr> </thead> <tbody> <tr> <td>MODE0</td> <td>All sizes: 100 sheets</td> </tr> <tr> <td>MODE1</td> <td>A3 and Ledger sizes: 70, other sizes: 100</td> </tr> <tr> <td>MODE2</td> <td>A3 and Ledger sizes: 50, other sizes: 100</td> </tr> </tbody> </table> <p>Initial setting: MODE0</p> <ol style="list-style-type: none"> 3. Press the start key. The setting is set. 4. Turn the main power switch off and on. 	Display	Description	MODE0	All sizes: 100 sheets	MODE1	A3 and Ledger sizes: 70, other sizes: 100	MODE2	A3 and Ledger sizes: 50, other sizes: 100
Display	Description								
MODE0	All sizes: 100 sheets								
MODE1	A3 and Ledger sizes: 70, other sizes: 100								
MODE2	A3 and Ledger sizes: 50, other sizes: 100								
<p>U236</p>	<p>Setting the limit for the ejection section of the built-in finisher</p> <p>Description If the machine is equipped with an built-in finisher, this mode sets whether A5R/B5R/statement size paper is output to the machine top tray or not.</p> <p>Purpose If the machine is equipped with an built-in finisher and if paper jams occur due to curling of paper in the built-in ejection section when two-sided copying onto A5R/B5R/statement size paper is performed, this mode is used to change the setting to ON to disable ejection to the machine top tray.</p> <p>Setting</p> <ol style="list-style-type: none"> 1. Press the start key. 2. Select ON or OFF. <table border="1" data-bbox="333 1193 1398 1319"> <thead> <tr> <th>Display</th> <th>Description</th> </tr> </thead> <tbody> <tr> <td>ON</td> <td>Does not eject to the machine top tray.</td> </tr> <tr> <td>OFF</td> <td>Eject to the machine top tray.</td> </tr> </tbody> </table> <p>Initial setting: OFF</p> <ol style="list-style-type: none"> 3. Press the start key. The setting is set. <p>Completion Press the stop key. The screen for selecting a maintenance item No. is displayed.</p>	Display	Description	ON	Does not eject to the machine top tray.	OFF	Eject to the machine top tray.		
Display	Description								
ON	Does not eject to the machine top tray.								
OFF	Eject to the machine top tray.								

Maintenance item No.	Description																		
<p>U243</p>	<p>Checking the operation of the DP motors</p> <p>Description Turns the motors or solenoids in the DP on.</p> <p>Purpose To check the operation of the DP motors and solenoids.</p> <p>Method</p> <ol style="list-style-type: none"> 1. Press the start key. 2. Select the item to be operated. 3. Press the start key. The operation starts. <table border="1" data-bbox="333 564 1398 813"> <thead> <tr> <th>Display</th> <th>Motor and solenoid</th> <th>Operation</th> </tr> </thead> <tbody> <tr> <td>DP FEED MOT</td> <td>Original feed motor (OFM)</td> <td>In operation</td> </tr> <tr> <td>DP CON MOT</td> <td>Original conveying motor (OCM)</td> <td>In operation</td> </tr> <tr> <td>DP REV MOT</td> <td>Original switchback motor (OSBM)</td> <td>In operation</td> </tr> <tr> <td>DP RP SOL</td> <td>Switchback pressure solenoid (SBPSOL)</td> <td>On for 0.5 s</td> </tr> <tr> <td>DP RJ SOL</td> <td>Switchback feedshift solenoid (SBFSSOL)</td> <td>On for 0.5 s</td> </tr> </tbody> </table> <ol style="list-style-type: none"> 4. To turn each motor off, press the stop key. <p>Completion Press the stop key when operation stops. The screen for selecting a maintenance item No. is displayed.</p>	Display	Motor and solenoid	Operation	DP FEED MOT	Original feed motor (OFM)	In operation	DP CON MOT	Original conveying motor (OCM)	In operation	DP REV MOT	Original switchback motor (OSBM)	In operation	DP RP SOL	Switchback pressure solenoid (SBPSOL)	On for 0.5 s	DP RJ SOL	Switchback feedshift solenoid (SBFSSOL)	On for 0.5 s
Display	Motor and solenoid	Operation																	
DP FEED MOT	Original feed motor (OFM)	In operation																	
DP CON MOT	Original conveying motor (OCM)	In operation																	
DP REV MOT	Original switchback motor (OSBM)	In operation																	
DP RP SOL	Switchback pressure solenoid (SBPSOL)	On for 0.5 s																	
DP RJ SOL	Switchback feedshift solenoid (SBFSSOL)	On for 0.5 s																	
<p>U244</p>	<p>Checking the DP switches</p> <p>Description Displays the status of the respective switches in the DP.</p> <p>Purpose To check if respective switches in the DP operate correctly.</p> <p>Method</p> <ol style="list-style-type: none"> 1. Press the start key. 2. Turn the respective switches on and off manually to check the status. If the on-status of a switch is detected, the corresponding switch is displayed in reverse. <table border="1" data-bbox="333 1247 1398 1538"> <thead> <tr> <th>Display</th> <th>Switches</th> </tr> </thead> <tbody> <tr> <td>TMG SW</td> <td>DP timing switch (DPTSW)</td> </tr> <tr> <td>REV SW</td> <td>Original switchback switch (OSBSW)</td> </tr> <tr> <td>SET SW</td> <td>Original set switch (OSSW)</td> </tr> <tr> <td>SZ SW A</td> <td>Original size length switch (OSLSW)</td> </tr> <tr> <td>COV OP SW</td> <td>DP interlock switch (DPILSW)</td> </tr> <tr> <td>DP OP SW</td> <td>DP open/close switch (DPOCSW)</td> </tr> </tbody> </table> <p>Completion Press the stop key. The screen for selecting a maintenance item No. is displayed.</p>	Display	Switches	TMG SW	DP timing switch (DPTSW)	REV SW	Original switchback switch (OSBSW)	SET SW	Original set switch (OSSW)	SZ SW A	Original size length switch (OSLSW)	COV OP SW	DP interlock switch (DPILSW)	DP OP SW	DP open/close switch (DPOCSW)				
Display	Switches																		
TMG SW	DP timing switch (DPTSW)																		
REV SW	Original switchback switch (OSBSW)																		
SET SW	Original set switch (OSSW)																		
SZ SW A	Original size length switch (OSLSW)																		
COV OP SW	DP interlock switch (DPILSW)																		
DP OP SW	DP open/close switch (DPOCSW)																		

Maintenance item No.	Description																				
<p>U245</p>	<p>Checking messages Description Displays a list of messages on the touch panel of the operation panel. Purpose To check the messages to be displayed.</p> <p>Method</p> <ol style="list-style-type: none"> 1. Press the start key. 2. Select the item to be displayed. 3. Displays the message one by one using cursor up/down keys. Switches the language on the touch panel using the cursor +/- keys. When a message number is entered with the numeric keys and then the start key is pressed, the message corresponding the specified number is displayed. <p>Completion Press the stop key. The screen for selecting a maintenance item No. is displayed.</p>																				
<p>U246</p>	<p>Setting the finisher Description Provides various settings for the built-in finisher, if furnished. Purpose Adjusts the side registration cursor stop position if paper registration is poor or stapling is made outside the specified area.</p> <p>Setting</p> <ol style="list-style-type: none"> 1. Press the start key. 2. Select the desired cursor position. 3. Change the setting using the +/- or numeric keys. <table border="1" data-bbox="333 1070 1398 1359"> <thead> <tr> <th>Display</th> <th>Description</th> <th>Setting range</th> <th>Initial setting</th> <th>Change in value per step</th> </tr> </thead> <tbody> <tr> <td>FRONT</td> <td>Front side registration cursor stop position</td> <td>-4 to +4</td> <td>0</td> <td>0.566 mm</td> </tr> <tr> <td>REAR</td> <td>Rear side registration cursor stop position</td> <td>-4 to +4</td> <td>0</td> <td>0.566 mm</td> </tr> <tr> <td>END</td> <td>Trailing edge registration cursor stop position</td> <td>-4 to +4</td> <td>0</td> <td>0.566 mm</td> </tr> </tbody> </table> <ol style="list-style-type: none"> 4. Press the start key. The value is set. <p>Completion Press the stop key. The screen for selecting a maintenance item No. is displayed.</p>	Display	Description	Setting range	Initial setting	Change in value per step	FRONT	Front side registration cursor stop position	-4 to +4	0	0.566 mm	REAR	Rear side registration cursor stop position	-4 to +4	0	0.566 mm	END	Trailing edge registration cursor stop position	-4 to +4	0	0.566 mm
Display	Description	Setting range	Initial setting	Change in value per step																	
FRONT	Front side registration cursor stop position	-4 to +4	0	0.566 mm																	
REAR	Rear side registration cursor stop position	-4 to +4	0	0.566 mm																	
END	Trailing edge registration cursor stop position	-4 to +4	0	0.566 mm																	

Maintenance item No.	Description															
U247	<p>Setting the paper feed device</p> <p>Description Turns on motors and clutches of paper feeder.</p> <p>Purpose To check the operation of motors and clutches of paper feed device.</p> <p>Method</p> <ol style="list-style-type: none"> 1. Press the start key. The value varies depending to the option furnished. 2. Select the item to be operated. 3. Press the start key. The operation starts. <table border="1" data-bbox="335 566 1398 772"> <thead> <tr> <th>Display</th> <th>Motor and clutches</th> <th>Operation</th> </tr> </thead> <tbody> <tr> <td>DESK FEED</td> <td>PF drive motor (PFDM)</td> <td>In operation</td> </tr> <tr> <td>CLUTCH FEED</td> <td>PF paper conveying clutch (PFCCL)</td> <td>On for 1 s</td> </tr> <tr> <td>CLUTCH U</td> <td>PF paper feed clutch 1 (PFPFCL1)</td> <td>On for 1 s</td> </tr> <tr> <td>CLUTCH L</td> <td>PF paper feed clutch 2 (PFPFCL2)</td> <td>On for 1 s</td> </tr> </tbody> </table> <ol style="list-style-type: none"> 4. To turn each motor off, press the stop key. <p>Completion Press the stop key. The screen for selecting a maintenance item No. is displayed.</p>	Display	Motor and clutches	Operation	DESK FEED	PF drive motor (PFDM)	In operation	CLUTCH FEED	PF paper conveying clutch (PFCCL)	On for 1 s	CLUTCH U	PF paper feed clutch 1 (PFPFCL1)	On for 1 s	CLUTCH L	PF paper feed clutch 2 (PFPFCL2)	On for 1 s
Display	Motor and clutches	Operation														
DESK FEED	PF drive motor (PFDM)	In operation														
CLUTCH FEED	PF paper conveying clutch (PFCCL)	On for 1 s														
CLUTCH U	PF paper feed clutch 1 (PFPFCL1)	On for 1 s														
CLUTCH L	PF paper feed clutch 2 (PFPFCL2)	On for 1 s														
U250	<p>Setting the maintenance cycle</p> <p>Description Changes preset values for maintenance cycle and automatic grayscale adjustment.</p> <p>Purpose Provides changing the time when the message to acknowledge to conduct maintenance and automatic grayscale adjustment is periodically displayed.</p> <p>Setting</p> <ol style="list-style-type: none"> 1. Press the start key. The current pre-set value is displayed. <table border="1" data-bbox="335 1180 1398 1335"> <thead> <tr> <th>Display</th> <th>Description</th> <th>Setting range</th> </tr> </thead> <tbody> <tr> <td>Maintenance Count A</td> <td>Preset values for maintenance cycle</td> <td>0 to 9999999</td> </tr> <tr> <td>COUNT GRAY ADJUST*100</td> <td>Preset values for automatic grayscale adjustment</td> <td>0 to 99900*</td> </tr> </tbody> </table> <p>*: The setting can be changed by 100 per step.</p> <p>Clearing</p> <ol style="list-style-type: none"> 1. Select the item to be cleared. To clear all items, select [ALL CLEAR]. 2. Press the clear key. 3. Press the start key. The setting value is cleared. <p>Setting</p> <ol style="list-style-type: none"> 1. Select the item to be changed. 2. Enter the setting value using the +/- or numeric keys. 3. Press the start key. The setting value is set. <p>Completion Press the stop key. The screen for selecting a maintenance item No. is displayed.</p>	Display	Description	Setting range	Maintenance Count A	Preset values for maintenance cycle	0 to 9999999	COUNT GRAY ADJUST*100	Preset values for automatic grayscale adjustment	0 to 99900*						
Display	Description	Setting range														
Maintenance Count A	Preset values for maintenance cycle	0 to 9999999														
COUNT GRAY ADJUST*100	Preset values for automatic grayscale adjustment	0 to 99900*														

Maintenance item No.	Description									
<p>U251</p>	<p>Checking/clearing the maintenance count</p> <p>Description Displays and clears or changes the maintenance count and automatic grayscale adjustment count.</p> <p>Purpose To verify the maintenance counter count and automatic grayscale count. Also to clear the count during maintenance service.</p> <p>Method Press the start key. The maintenance count is displayed.</p> <table border="1" data-bbox="333 535 1398 660"> <thead> <tr> <th data-bbox="336 539 636 577">Display</th> <th data-bbox="636 539 1166 577">Description</th> <th data-bbox="1166 539 1394 577">Setting range</th> </tr> </thead> <tbody> <tr> <td data-bbox="336 577 636 616">Maintenance Count A</td> <td data-bbox="636 577 1166 616">Count value for maintenance cycle</td> <td data-bbox="1166 577 1394 616">0 to 9999999</td> </tr> <tr> <td data-bbox="336 616 636 654">COUNT GRAY ADJUST</td> <td data-bbox="636 616 1166 654">Automatic grayscale adjustment count</td> <td data-bbox="1166 616 1394 654">0 to 9999999</td> </tr> </tbody> </table> <p>Clearing</p> <ol style="list-style-type: none"> 1. Select the item to be cleared. To clear all items, select [ALL CLEAR]. 2. Press the clear key. 3. Press the start key. The count is cleared. <p>Setting</p> <ol style="list-style-type: none"> 1. Select the item to be changed. 2. Enter the count using the numeric keys. 3. Press the start key. The count is set. <p>Completion Press the stop key. The screen for selecting a maintenance item No. is displayed.</p>	Display	Description	Setting range	Maintenance Count A	Count value for maintenance cycle	0 to 9999999	COUNT GRAY ADJUST	Automatic grayscale adjustment count	0 to 9999999
Display	Description	Setting range								
Maintenance Count A	Count value for maintenance cycle	0 to 9999999								
COUNT GRAY ADJUST	Automatic grayscale adjustment count	0 to 9999999								

Maintenance item No.	Description														
U252	<p>Setting the destination</p> <p>Description Switches the operations and screens of the machine according to the destination.</p> <p>Purpose To be executed after initializing the backup RAM, in order to return the setting to the value before replacement or initialization.</p> <p>Setting</p> <ol style="list-style-type: none"> 1. Press the start key. 2. Select the destination. <table border="1" data-bbox="331 564 1398 855"> <thead> <tr> <th data-bbox="336 564 636 607">Display</th> <th data-bbox="636 564 1398 607">Description</th> </tr> </thead> <tbody> <tr> <td data-bbox="336 607 636 645">EUROPE METRIC</td> <td data-bbox="636 607 1398 645">Metric (Europe) specifications</td> </tr> <tr> <td data-bbox="336 645 636 683">INCH</td> <td data-bbox="636 645 1398 683">Inch (North America) specifications</td> </tr> <tr> <td data-bbox="336 683 636 721">ASIA PACIFIC</td> <td data-bbox="636 683 1398 721">Metric (Asia Pacific) specifications</td> </tr> <tr> <td data-bbox="336 721 636 759">AUSTRALIA</td> <td data-bbox="636 721 1398 759">Australia specifications</td> </tr> <tr> <td data-bbox="336 759 636 797">CHINA</td> <td data-bbox="636 759 1398 797">China specifications</td> </tr> <tr> <td data-bbox="336 797 636 835">KOREA</td> <td data-bbox="636 797 1398 835">Korea specifications</td> </tr> </tbody> </table> <ol style="list-style-type: none"> 3. Press the start key. The setting is set. 4. Turn the main power switch off and on. 	Display	Description	EUROPE METRIC	Metric (Europe) specifications	INCH	Inch (North America) specifications	ASIA PACIFIC	Metric (Asia Pacific) specifications	AUSTRALIA	Australia specifications	CHINA	China specifications	KOREA	Korea specifications
Display	Description														
EUROPE METRIC	Metric (Europe) specifications														
INCH	Inch (North America) specifications														
ASIA PACIFIC	Metric (Asia Pacific) specifications														
AUSTRALIA	Australia specifications														
CHINA	China specifications														
KOREA	Korea specifications														

Maintenance item No.	Description										
<p>U253</p>	<p>Switching between double and single counts</p> <p>Description Switches the count system for the total counter and other counters.</p> <p>Purpose Used to select, according to the preference of the user (copy service provider), if A3/Ledger paper is to be counted as one sheet (single count) or two sheets (double count).</p> <p>Setting</p> <ol style="list-style-type: none"> 1. Press the start key. 2. Select the count system. <table border="1" data-bbox="333 564 1398 772"> <thead> <tr> <th>Display</th> <th>Description</th> </tr> </thead> <tbody> <tr> <td>ALL SINGLE</td> <td>Single count for all size paper</td> </tr> <tr> <td>DOUBLE COUNT(A3/LEDGER)</td> <td>Double count for A3/Ledger size or larger</td> </tr> <tr> <td>DOUBLE COUNT(B4)</td> <td>Double count for B4 size or larger</td> </tr> <tr> <td>DOUBLE COUNT(FOLIO/LEGAL)</td> <td>Double count for FOLIO/Legal size or larger</td> </tr> </tbody> </table> <p>Initial setting: DOUBLE COUNT(A3/LEDGER)</p> <ol style="list-style-type: none"> 3. Press the start key. The setting is set. <p>Completion Press the stop key. The screen for selecting a maintenance item No. is displayed.</p>	Display	Description	ALL SINGLE	Single count for all size paper	DOUBLE COUNT(A3/LEDGER)	Double count for A3/Ledger size or larger	DOUBLE COUNT(B4)	Double count for B4 size or larger	DOUBLE COUNT(FOLIO/LEGAL)	Double count for FOLIO/Legal size or larger
Display	Description										
ALL SINGLE	Single count for all size paper										
DOUBLE COUNT(A3/LEDGER)	Double count for A3/Ledger size or larger										
DOUBLE COUNT(B4)	Double count for B4 size or larger										
DOUBLE COUNT(FOLIO/LEGAL)	Double count for FOLIO/Legal size or larger										
<p>U260</p>	<p>Selecting the timing for copy counting</p> <p>Description Changes the copy count timing for the total counter and other counters.</p> <p>Purpose To be set according to user (copy service provider) request. If a paper jam occurs frequently in the optional document finisher when the number of copies is counted at the time of paper ejection, copies are provided without copy counts. The copy service provider cannot charge for such copying. To prevent this, the copy timing should be made earlier. If a paper jam occurs frequently in the paper conveying or fuser sections when the number of copies is counted before the paper reaches those sections, copying is charged without a copy being made. To prevent this, the copy timing should be made later.</p> <p>Setting</p> <ol style="list-style-type: none"> 1. Press the start key. 2. Select the copy count timing. <table border="1" data-bbox="333 1388 1398 1512"> <thead> <tr> <th>Display</th> <th>Description</th> </tr> </thead> <tbody> <tr> <td>FEED</td> <td>When secondary paper feed starts</td> </tr> <tr> <td>EJECT</td> <td>When the paper is ejected</td> </tr> </tbody> </table> <p>Initial setting: EJECT</p> <ol style="list-style-type: none"> 3. Press the start key. The setting is set. <p>Completion Press the stop key. The screen for selecting a maintenance item No. is displayed.</p>	Display	Description	FEED	When secondary paper feed starts	EJECT	When the paper is ejected				
Display	Description										
FEED	When secondary paper feed starts										
EJECT	When the paper is ejected										

Maintenance item No.	Description
U265	<p>Setting OEM purchaser code</p> <p>Description Sets the OEM purchaser code.</p> <p>Purpose Sets the code when replacing the main PWB and the like.</p> <p>Setting</p> <ol style="list-style-type: none"> 1. Press the start key. 2. Change the preset value using the numeric keys. 3. Press the start key. The setting is set. 4. Turn the main power switch off and on.
U278	<p>Setting the delivery date</p> <p>Description Enter delivery date in month, day, and year.</p> <p>Purpose To operate when installing the machine. Perform this to confirm the delivery date.</p> <p>Method</p> <ol style="list-style-type: none"> 1. Press the start key. 2. Select [TODAY]. 3. Press the start key. The delivery date is set. <p>Clearing</p> <ol style="list-style-type: none"> 1. Select [CLEAR]. 2. Press the start key. The delivery date is cleared. <p>Completion Press the stop key. The screen for selecting a maintenance item No. is displayed.</p>
U285	<p>Setting service status page</p> <p>Description Determines displaying the digital dot coverage report on reporting.</p> <p>Purpose According to user request, changes the setting.</p> <p>Method</p> <ol style="list-style-type: none"> 1. Press the start key. 2. Press [COVERAGE]. Select ON or OFF. Initial setting: ON 3. Press the start key. The setting is set. <p>Completion Press the stop key. The screen for selecting a maintenance item No. is displayed.</p>

Maintenance item No.	Description																				
U326	<p>Setting the black line cleaning indication</p> <p>Description Sets whether to display the cleaning guidance when detecting the black line.</p> <p>Purpose Displays the cleaning guidance in order to make the call for service with the black line decrease by the rubbish on the contact glass when scanning from the DP.</p> <p>Setting</p> <ol style="list-style-type: none"> Press the start key. Select the item to set. The screen for setting each item is displayed. <table border="1" style="width: 100%; border-collapse: collapse;"> <thead> <tr> <th style="text-align: left;">Display</th> <th style="text-align: left;">Description</th> </tr> </thead> <tbody> <tr> <td>BLACK LINE MODE</td> <td>Black line cleaning guidance ON/OFF setting</td> </tr> <tr> <td>BLACK LINE COUNT</td> <td>Setting counts of the cleaning guidance indication</td> </tr> </tbody> </table> <p>Setting: [BLACK LINE MODE]</p> <ol style="list-style-type: none"> Select ON or OFF. <table border="1" style="width: 100%; border-collapse: collapse;"> <thead> <tr> <th style="text-align: left;">Display</th> <th style="text-align: left;">Description</th> </tr> </thead> <tbody> <tr> <td>ON</td> <td>Displays the cleaning guidance</td> </tr> <tr> <td>OFF</td> <td>Not to display the cleaning guidance</td> </tr> </tbody> </table> <p>Initial setting: ON Setting count value is displayed only if the setting is ON.</p> <ol style="list-style-type: none"> Press the start key. The setting is set. <p>Setting: [BLACK LINE COUNT]</p> <ol style="list-style-type: none"> Change the setting value using the +/- or numeric keys. <table border="1" style="width: 100%; border-collapse: collapse;"> <thead> <tr> <th style="text-align: left;">Display</th> <th style="text-align: left;">Description</th> <th style="text-align: left;">Setting range</th> <th style="text-align: left;">Initial setting</th> </tr> </thead> <tbody> <tr> <td>COUNT *1000</td> <td>Setting counts of the cleaning guidance indication (x 1000 sheets)</td> <td>0 to 255</td> <td>8</td> </tr> </tbody> </table> <p>When setting is 0, the black line cleaning indication is displayed only if the black line is detected.</p> <ol style="list-style-type: none"> Press the start key. The value is set. <p>Completion Press the stop key. The screen for selecting a maintenance item No. is displayed.</p>	Display	Description	BLACK LINE MODE	Black line cleaning guidance ON/OFF setting	BLACK LINE COUNT	Setting counts of the cleaning guidance indication	Display	Description	ON	Displays the cleaning guidance	OFF	Not to display the cleaning guidance	Display	Description	Setting range	Initial setting	COUNT *1000	Setting counts of the cleaning guidance indication (x 1000 sheets)	0 to 255	8
Display	Description																				
BLACK LINE MODE	Black line cleaning guidance ON/OFF setting																				
BLACK LINE COUNT	Setting counts of the cleaning guidance indication																				
Display	Description																				
ON	Displays the cleaning guidance																				
OFF	Not to display the cleaning guidance																				
Display	Description	Setting range	Initial setting																		
COUNT *1000	Setting counts of the cleaning guidance indication (x 1000 sheets)	0 to 255	8																		

Maintenance item No.	Description								
U328	<p>Side ejection setting</p> <p>Description Sets whether to eject to the side of the machine when an optional curl eliminator is installed.</p> <p>Purpose Set according to the preference of the user.</p> <p>Setting</p> <ol style="list-style-type: none"> 1. Press the start key. 2. Select [ON] or [OFF]. <table border="1" data-bbox="333 535 1398 660"> <thead> <tr> <th>Display</th> <th>Description</th> </tr> </thead> <tbody> <tr> <td>ON</td> <td>To eject to the side of the machine</td> </tr> <tr> <td>OFF</td> <td>Not to eject to the side of the machine</td> </tr> </tbody> </table> <p>Initial setting: OFF</p> <ol style="list-style-type: none"> 3. Press the start key. The setting is set. 4. Turn the main power switch off and on. 	Display	Description	ON	To eject to the side of the machine	OFF	Not to eject to the side of the machine		
Display	Description								
ON	To eject to the side of the machine								
OFF	Not to eject to the side of the machine								
U332	<p>Setting the size conversion factor</p> <p>Description Sets the coefficient of nonstandard sizes in relation to the A4/Letter size. The coefficient set here is used to convert the black ratio in relation to the A4/Letter size and to display the result in user simulation.</p> <p>Purpose To set the coefficient for converting the black ratio for nonstandard sizes in relation to the A4/Letter size.</p> <p>Setting</p> <ol style="list-style-type: none"> 1. Press the start key. 2. Change the setting using the +/- or numeric keys. <table border="1" data-bbox="333 1099 1398 1180"> <thead> <tr> <th>Display</th> <th>Description</th> <th>Setting range</th> <th>Initial setting</th> </tr> </thead> <tbody> <tr> <td>Calculation Rate</td> <td>Size parameter</td> <td>0.1 to 3.0</td> <td>1.0</td> </tr> </tbody> </table> <ol style="list-style-type: none"> 3. Press the start key. The setting is set. <p>Completion Press the stop key. The screen for selecting a maintenance item No. is displayed.</p>	Display	Description	Setting range	Initial setting	Calculation Rate	Size parameter	0.1 to 3.0	1.0
Display	Description	Setting range	Initial setting						
Calculation Rate	Size parameter	0.1 to 3.0	1.0						

Maintenance item No.	Description										
U339	<p>Setting the drum heater ON/OFF</p> <p>Description Turns the drum heater on or off during sleep mode.</p> <p>Purpose Set according to the preference of the user.</p> <p>Setting</p> <ol style="list-style-type: none"> 1. Press the start key. 2. Change the setting using the +/- or numeric keys. <table border="1" data-bbox="336 535 1398 618"> <thead> <tr> <th>Display</th> <th>Description</th> <th>Setting range</th> <th>Initial setting</th> </tr> </thead> <tbody> <tr> <td>MODE</td> <td>Setting the drum heater ON/OFF</td> <td>0 to 4*</td> <td>0</td> </tr> </tbody> </table> <p>*: The drum heater is off at sleep mode when the value is 0. The drum heater is on at sleep mode when the value is between 1 and 4.</p> <ol style="list-style-type: none"> 3. Press the start key. The setting is set. <p>Completion Press the stop key. The screen for selecting a maintenance item No. is displayed.</p>	Display	Description	Setting range	Initial setting	MODE	Setting the drum heater ON/OFF	0 to 4*	0		
Display	Description	Setting range	Initial setting								
MODE	Setting the drum heater ON/OFF	0 to 4*	0								
U341	<p>Specific paper feed location setting for printing function</p> <p>Description Sets a paper feed location specified for printer output.</p> <p>Purpose To use a paper feed location only for printer output. A paper feed location specified for printer output cannot be used for copy output.</p> <p>Method</p> <ol style="list-style-type: none"> 1. Press the start key. 2. Select the paper feed location for the printer. Two or more cassette can be selected. <table border="1" data-bbox="336 1142 1398 1346"> <thead> <tr> <th>Display</th> <th>Description</th> </tr> </thead> <tbody> <tr> <td>CASSETTE 1</td> <td>Cassette 1</td> </tr> <tr> <td>CASSETTE 2</td> <td>Cassette 2</td> </tr> <tr> <td>CASSETTE 3</td> <td>Cassette 3 (optional paper feeder)</td> </tr> <tr> <td>CASSETTE 4</td> <td>Cassette 4 (optional paper feeder)</td> </tr> </tbody> </table> <p>When an optional paper feed device is not installed, the corresponding count is not displayed.</p> <ol style="list-style-type: none"> 3. Press the start key. The setting is set. <p>Completion Press the stop key. The screen for selecting a maintenance item No. is displayed.</p>	Display	Description	CASSETTE 1	Cassette 1	CASSETTE 2	Cassette 2	CASSETTE 3	Cassette 3 (optional paper feeder)	CASSETTE 4	Cassette 4 (optional paper feeder)
Display	Description										
CASSETTE 1	Cassette 1										
CASSETTE 2	Cassette 2										
CASSETTE 3	Cassette 3 (optional paper feeder)										
CASSETTE 4	Cassette 4 (optional paper feeder)										

Maintenance item No.	Description														
U342	<p>Setting the ejection restriction</p> <p>Description Sets or cancels the restriction on the number of sheets to be ejected continuously when the internal eject tray is selected as the eject location.</p> <p>Purpose According to user request, sets or cancels restriction on the number of sheets.</p> <p>Setting</p> <ol style="list-style-type: none"> 1. Press the start key. 2. Select [ON] or [OFF]. <table border="1" data-bbox="333 564 1396 689"> <thead> <tr> <th>Display</th> <th>Description</th> </tr> </thead> <tbody> <tr> <td>ON</td> <td>Sets restriction on the number of sheets</td> </tr> <tr> <td>OFF</td> <td>Cancels restriction on the number of sheets</td> </tr> </tbody> </table> <p>Initial setting: ON</p> <p>Details of restriction (number of sheets to be ejected continuously after the start key is pressed)</p> <table border="1" data-bbox="333 788 1396 956"> <thead> <tr> <th>Condition</th> <th>Number of sheets</th> </tr> </thead> <tbody> <tr> <td>When no optional ejection device is installed</td> <td>250 sheets</td> </tr> <tr> <td>When the job separator is installed</td> <td>150 sheets</td> </tr> <tr> <td>When the finisher is installed</td> <td>100 sheets</td> </tr> </tbody> </table> <ol style="list-style-type: none"> 3. Press the start key. The setting is set. <p>Completion Press the stop key. The screen for selecting a maintenance item No. is displayed.</p>	Display	Description	ON	Sets restriction on the number of sheets	OFF	Cancels restriction on the number of sheets	Condition	Number of sheets	When no optional ejection device is installed	250 sheets	When the job separator is installed	150 sheets	When the finisher is installed	100 sheets
Display	Description														
ON	Sets restriction on the number of sheets														
OFF	Cancels restriction on the number of sheets														
Condition	Number of sheets														
When no optional ejection device is installed	250 sheets														
When the job separator is installed	150 sheets														
When the finisher is installed	100 sheets														
U343	<p>Switching between duplex/simplex copy mode</p> <p>Description Switches the initial setting between duplex and simplex copy.</p> <p>Purpose To be set according to frequency of use: set to the more frequently used mode.</p> <p>Setting</p> <ol style="list-style-type: none"> 1. Press the start key. 2. Select ON or OFF. <table border="1" data-bbox="333 1361 1396 1487"> <thead> <tr> <th>Display</th> <th>Description</th> </tr> </thead> <tbody> <tr> <td>ON</td> <td>Duplex copy</td> </tr> <tr> <td>OFF</td> <td>Simplex copy</td> </tr> </tbody> </table> <p>Initial setting: OFF</p> <ol style="list-style-type: none"> 3. Press the start key. The setting is set. <p>Completion Press the stop key. The screen for selecting a maintenance item No. is displayed.</p>	Display	Description	ON	Duplex copy	OFF	Simplex copy								
Display	Description														
ON	Duplex copy														
OFF	Simplex copy														

Maintenance item No.	Description						
<p>U345</p>	<p>Setting the value for maintenance due indication</p> <p>Description Sets when to display a message notifying that the time for maintenance is about to be reached, by setting the number of copies that can be made before the current maintenance cycle ends. When the difference between the number of copies of the maintenance cycle and that of the maintenance count reaches the set value, the message is displayed.</p> <p>Purpose To change the time for maintenance due indication.</p> <p>Setting</p> <ol style="list-style-type: none"> 1. Press the start key. 2. Change the setting using the +/- or numeric keys. <table border="1" data-bbox="333 609 1398 750"> <thead> <tr> <th data-bbox="336 613 523 651">Display</th> <th data-bbox="523 613 1168 651">Description</th> <th data-bbox="1168 613 1394 651">Setting range</th> </tr> </thead> <tbody> <tr> <td data-bbox="336 651 523 745">COUNT</td> <td data-bbox="523 651 1168 745">Time for maintenance due indication (Remaining number of copies that can be made before the current maintenance cycle ends)</td> <td data-bbox="1168 651 1394 745">0 to 9999</td> </tr> </tbody> </table> <ol style="list-style-type: none"> 3. Press the start key. The value is set. <p>Completion Press the stop key. The screen for selecting a maintenance item No. is displayed.</p>	Display	Description	Setting range	COUNT	Time for maintenance due indication (Remaining number of copies that can be made before the current maintenance cycle ends)	0 to 9999
Display	Description	Setting range					
COUNT	Time for maintenance due indication (Remaining number of copies that can be made before the current maintenance cycle ends)	0 to 9999					

Maintenance item No.	Description																																			
<p>U402</p>	<p>Adjusting margins of image printing</p> <p>Description Adjusts margins for image printing.</p> <p>Purpose Make the adjustment if margins are incorrect.</p> <p>Adjustment</p> <ol style="list-style-type: none"> 1. Press the start key. 2. Select the item to be adjusted. <table border="1" data-bbox="331 533 1398 913"> <thead> <tr> <th>Display</th> <th>Description</th> <th>Setting range</th> <th>Initial setting</th> <th>Change in value per step</th> </tr> </thead> <tbody> <tr> <td>LEAD</td> <td>Printer leading edge margin</td> <td>0 to 10.0</td> <td>4.0</td> <td>0.1 mm</td> </tr> <tr> <td>A</td> <td>Printer left margin</td> <td>0 to 10.0</td> <td>3.0</td> <td>0.1 mm</td> </tr> <tr> <td>C</td> <td>Printer right margin</td> <td>0 to 10.0</td> <td>3.0</td> <td>0.1 mm</td> </tr> <tr> <td>TRAIL</td> <td>Printer trailing edge margin</td> <td>0 to 10.0</td> <td>3.9</td> <td>0.1 mm</td> </tr> <tr> <td>TRAIL(DUP)</td> <td>Printer trailing edge margin (second side)</td> <td>0 to 10.0</td> <td>4.0</td> <td>0.1 mm</td> </tr> <tr> <td>TRAIL(MPT)</td> <td>Printer trailing edge margin (MP tray)</td> <td>0 to 10.0</td> <td>4.0</td> <td>0.1 mm</td> </tr> </tbody> </table> <ol style="list-style-type: none"> 3. Press the system menu key. 4. Press the start key to output a test pattern. 5. Press the system menu key. 6. Change the setting value using the +/- or numeric keys. Increasing the value makes the margin wider, and decreasing it makes the margin narrower. <div data-bbox="558 1093 1142 1487" style="text-align: center;"> </div> <p>Figure 1-3-17</p> <ol style="list-style-type: none"> 7. Press the start key. The value is set. <p>Caution Check the copy image after the adjustment. If the image is still incorrect, perform the following adjustments in maintenance mode.</p> <div data-bbox="284 1720 826 1796" style="text-align: center;"> <pre> graph LR U402[U402] --> U403[U403 (P.1-3-72)] U403 --> U404[U404 (P.1-3-73)] </pre> </div> <p>Completion Press the stop key. The screen for selecting a maintenance item No. is displayed.</p>	Display	Description	Setting range	Initial setting	Change in value per step	LEAD	Printer leading edge margin	0 to 10.0	4.0	0.1 mm	A	Printer left margin	0 to 10.0	3.0	0.1 mm	C	Printer right margin	0 to 10.0	3.0	0.1 mm	TRAIL	Printer trailing edge margin	0 to 10.0	3.9	0.1 mm	TRAIL(DUP)	Printer trailing edge margin (second side)	0 to 10.0	4.0	0.1 mm	TRAIL(MPT)	Printer trailing edge margin (MP tray)	0 to 10.0	4.0	0.1 mm
Display	Description	Setting range	Initial setting	Change in value per step																																
LEAD	Printer leading edge margin	0 to 10.0	4.0	0.1 mm																																
A	Printer left margin	0 to 10.0	3.0	0.1 mm																																
C	Printer right margin	0 to 10.0	3.0	0.1 mm																																
TRAIL	Printer trailing edge margin	0 to 10.0	3.9	0.1 mm																																
TRAIL(DUP)	Printer trailing edge margin (second side)	0 to 10.0	4.0	0.1 mm																																
TRAIL(MPT)	Printer trailing edge margin (MP tray)	0 to 10.0	4.0	0.1 mm																																

Maintenance item No.	Description																												
<p>U403</p>	<p>Adjusting margins for scanning an original on the platen</p> <p>Description Adjusts margins for scanning the original on the contact glass.</p> <p>Purpose Make the adjustment if margins are incorrect.</p> <p>Adjustment</p> <ol style="list-style-type: none"> 1. Press the start key. 2. Select the item to be adjusted. <table border="1" data-bbox="331 533 1396 772"> <thead> <tr> <th>Display</th> <th>Description</th> <th>Setting range</th> <th>Initial setting</th> <th>Change in value per step</th> </tr> </thead> <tbody> <tr> <td>A MARGIN</td> <td>Scanner left margin</td> <td>0 to 10.0</td> <td>2.0</td> <td>0.5 mm</td> </tr> <tr> <td>B MARGIN</td> <td>Scanner leading edge margin</td> <td>0 to 10.0</td> <td>2.0</td> <td>0.5 mm</td> </tr> <tr> <td>C MARGIN</td> <td>Scanner right margin</td> <td>0 to 10.0</td> <td>2.0</td> <td>0.5 mm</td> </tr> <tr> <td>D MARGIN</td> <td>Scanner trailing edge margin</td> <td>0 to 10.0</td> <td>2.0</td> <td>0.5 mm</td> </tr> </tbody> </table> <ol style="list-style-type: none"> 3. Press the system menu key. 4. Place an original and press the start key to make a test copy. 5. Press the system menu key. 6. Change the setting value using the +/- keys. Increasing the value makes the margin wider, and decreasing it makes the margin narrower. <div data-bbox="539 952 1165 1400" style="text-align: center;"> <p>The diagram shows a rectangular scanner bed with four margin indicators. At the top, a double-headed arrow indicates the 'Scanner leading edge margin' with a range of $(3.0 \pm 2.5 \text{ mm})$. On the left side, a double-headed arrow indicates the 'Scanner left margin' with a range of $(2.5 + 1.5/-2.0 \text{ mm})$. On the right side, a double-headed arrow indicates the 'Scanner right margin' with a range of $(2.5 + 1.5/-2.0 \text{ mm})$. At the bottom, a double-headed arrow indicates the 'Scanner trailing edge margin' with a range of $(3.0 \pm 2.0 \text{ mm})$.</p> </div> <p style="text-align: center;">Figure 1-3-18</p> <ol style="list-style-type: none"> 7. Press the start key. The value is set. <p>Caution Check the copy image after the adjustment. If the image is still incorrect, perform the following adjustments in maintenance mode.</p> <div data-bbox="287 1635 622 1713" style="text-align: center;"> <table border="1"> <tr> <td style="padding: 5px;">U403</td> <td style="text-align: center; vertical-align: middle;">→</td> <td style="padding: 5px;">U404 (P.1-3-73)</td> </tr> </table> </div> <p>Completion Press the stop key. The indication for selecting a maintenance item No. appears.</p>	Display	Description	Setting range	Initial setting	Change in value per step	A MARGIN	Scanner left margin	0 to 10.0	2.0	0.5 mm	B MARGIN	Scanner leading edge margin	0 to 10.0	2.0	0.5 mm	C MARGIN	Scanner right margin	0 to 10.0	2.0	0.5 mm	D MARGIN	Scanner trailing edge margin	0 to 10.0	2.0	0.5 mm	U403	→	U404 (P.1-3-73)
Display	Description	Setting range	Initial setting	Change in value per step																									
A MARGIN	Scanner left margin	0 to 10.0	2.0	0.5 mm																									
B MARGIN	Scanner leading edge margin	0 to 10.0	2.0	0.5 mm																									
C MARGIN	Scanner right margin	0 to 10.0	2.0	0.5 mm																									
D MARGIN	Scanner trailing edge margin	0 to 10.0	2.0	0.5 mm																									
U403	→	U404 (P.1-3-73)																											

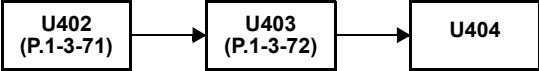
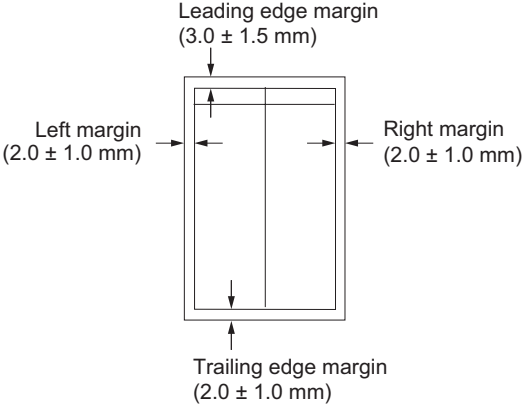
Maintenance item No.	Description																									
U404	<p>Adjusting margins for scanning an original from the DP</p> <p>Description Adjusts margins for scanning the original from the DP.</p> <p>Purpose Make the adjustment if margins are incorrect when the DP is used.</p> <p>Caution Before making this adjustment, ensure that the following adjustments have been made in maintenance mode.</p> <div style="text-align: center;">  <pre> graph LR U402[U402 (P.1-3-71)] --> U403[U403 (P.1-3-72)] U403 --> U404[U404] </pre> </div> <p>Adjustment</p> <ol style="list-style-type: none"> Press the start key. Select the item to be adjusted. <table border="1" data-bbox="333 712 1398 952"> <thead> <tr> <th>Display</th> <th>Description</th> <th>Setting range</th> <th>Initial setting</th> <th>Change in value per step</th> </tr> </thead> <tbody> <tr> <td>A MARGIN</td> <td>Left margin</td> <td>0 to 10.0</td> <td>3.0</td> <td>0.5 mm</td> </tr> <tr> <td>B MARGIN</td> <td>Leading edge margin</td> <td>0 to 10.0</td> <td>2.5</td> <td>0.5 mm</td> </tr> <tr> <td>C MARGIN</td> <td>Right margin</td> <td>0 to 10.0</td> <td>3.0</td> <td>0.5 mm</td> </tr> <tr> <td>D MARGIN</td> <td>Trailing edge margin</td> <td>0 to 10.0</td> <td>4.0</td> <td>0.5 mm</td> </tr> </tbody> </table> <ol style="list-style-type: none"> Press the system menu key. Place an original on the DP and press the start key to make a test copy. Press the system menu key. Change the setting value using the +/- keys. Increasing the value makes the margin wider, and decreasing it makes the margin narrower. <div style="text-align: center;">  </div> <p>Figure 1-3-19</p> <ol style="list-style-type: none"> Press the start key. The value is set. <p>Completion Press the stop key. The screen for selecting a maintenance item No. is displayed.</p>	Display	Description	Setting range	Initial setting	Change in value per step	A MARGIN	Left margin	0 to 10.0	3.0	0.5 mm	B MARGIN	Leading edge margin	0 to 10.0	2.5	0.5 mm	C MARGIN	Right margin	0 to 10.0	3.0	0.5 mm	D MARGIN	Trailing edge margin	0 to 10.0	4.0	0.5 mm
Display	Description	Setting range	Initial setting	Change in value per step																						
A MARGIN	Left margin	0 to 10.0	3.0	0.5 mm																						
B MARGIN	Leading edge margin	0 to 10.0	2.5	0.5 mm																						
C MARGIN	Right margin	0 to 10.0	3.0	0.5 mm																						
D MARGIN	Trailing edge margin	0 to 10.0	4.0	0.5 mm																						

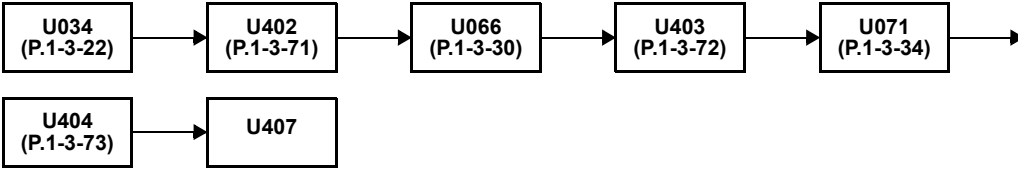
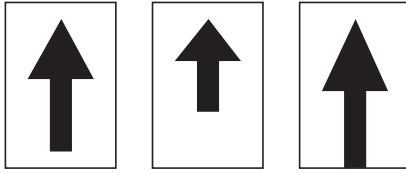
Maintenance item No.	Description										
<p>U407</p>	<p>Adjusting the leading edge registration for memory image printing</p> <p>Description Adjusts the leading edge registration during memory copying.</p> <p>Purpose Make the following adjustment if there is a regular error between the leading edge of the copy image on the front face and that on the reverse face during duplex switchback copying.</p> <p>Caution Before making this adjustment, ensure that the following adjustments have been made in maintenance mode.</p> <div style="text-align: center;">  <pre> graph LR U034["U034 (P.1-3-22)"] --> U402["U402 (P.1-3-71)"] U402 --> U066["U066 (P.1-3-30)"] U066 --> U403["U403 (P.1-3-72)"] U403 --> U071["U071 (P.1-3-34)"] U071 --> U404["U404 (P.1-3-73)"] U404 --> U407["U407"] </pre> </div> <p>Adjustment</p> <ol style="list-style-type: none"> Press the start key. <table border="1" data-bbox="331 810 1396 954"> <thead> <tr> <th>Display</th> <th>Description</th> <th>Setting range</th> <th>Initial setting</th> <th>Change in value per step</th> </tr> </thead> <tbody> <tr> <td>ADJUST DATA</td> <td>Leading edge registration for memory image printing</td> <td>-47 to 47</td> <td>0</td> <td>0.1 mm</td> </tr> </tbody> </table> <ol style="list-style-type: none"> Press the system menu key. Place an original and press the start key to make a test copy. Press the system menu key. Change the setting value using the +/- or numeric keys. For copy example 1, decrease the value. For copy example 2, increase the value. <div style="text-align: center;">  <p>Original Copy example 1 Copy example 2</p> </div> <p>Figure 1-3-20</p> <ol style="list-style-type: none"> Press the start key. The value is set. <p>Completion Press the stop key. The screen for selecting a maintenance item No. is displayed.</p>	Display	Description	Setting range	Initial setting	Change in value per step	ADJUST DATA	Leading edge registration for memory image printing	-47 to 47	0	0.1 mm
Display	Description	Setting range	Initial setting	Change in value per step							
ADJUST DATA	Leading edge registration for memory image printing	-47 to 47	0	0.1 mm							

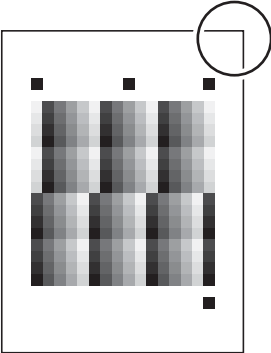
Maintenance item No.	Description										
U410	<p>Adjusting the halftone automatically</p> <p>Description Carries out processing for the data acquisition that is required in order to perform automatic adjustment of the halftone.</p> <p>Purpose Performed when the quality of reproduced halftones has dropped.</p> <p>Method</p> <ol style="list-style-type: none"> 1. Press the start key. 2. Select [EXECUTE]. 3. Press the start key. A test pattern is outputted. 4. Place the output test pattern as the original. Align the corner inside the circle with the left inside corner of the original marker. <div data-bbox="715 674 986 1025" style="text-align: center;">  <p>Test pattern</p> </div> <p style="text-align: center;">Figure 1-3-21</p> <ol style="list-style-type: none"> 5. Place approximately 20 sheets of white paper on the test pattern and set them. 6. Press the start key. Adjustment is made. 7. When normally completed, [ALL COMP.] is displayed. If a problem occurs during auto adjustment, error code is displayed. <p>Error codes</p> <table border="1" data-bbox="333 1335 1398 1529"> <thead> <tr> <th>Codes</th> <th>Description</th> </tr> </thead> <tbody> <tr> <td>S01</td> <td>Patch not detected</td> </tr> <tr> <td>S02</td> <td>Original deviation in the main scanning direction</td> </tr> <tr> <td>S03</td> <td>Original deviation in the auxiliary scanning direction</td> </tr> <tr> <td>S04</td> <td>Original inclination error</td> </tr> </tbody> </table> <p>If [S**] appears, check the original. If [C**] appears, execute again maintenance item U410.</p> <p>Completion Press the stop key. The screen for selecting a maintenance item No. is displayed.</p>	Codes	Description	S01	Patch not detected	S02	Original deviation in the main scanning direction	S03	Original deviation in the auxiliary scanning direction	S04	Original inclination error
Codes	Description										
S01	Patch not detected										
S02	Original deviation in the main scanning direction										
S03	Original deviation in the auxiliary scanning direction										
S04	Original inclination error										

Maintenance item No.	Description																							
<p>U411</p>	<p>Adjusting the scanner automatically</p> <p>Description Uses a specified original and automatically adjusts the following items in the scanner and the DP scanning sections.</p> <p>Purpose To perform automatic adjustment of various items in the scanner and the DP scanning sections.</p> <p>Method</p> <ol style="list-style-type: none"> 1. Press the start key. 2. Select the item. The screen for executing is displayed. <table border="1" data-bbox="333 564 1398 748"> <thead> <tr> <th>Display</th> <th>Description</th> <th>Original to be used for adjustment (P/N)</th> </tr> </thead> <tbody> <tr> <td>SCANNER</td> <td>Automatic adjustment in the scanner section</td> <td>302FZ56990</td> </tr> <tr> <td>DP(FACE UP)</td> <td>Automatic adjustment in the DP scanning section (first page)</td> <td>302AC68243</td> </tr> </tbody> </table> <p>Method: [SCANNER]</p> <ol style="list-style-type: none"> 1. Enter the target values which are shown on the specified original (P/N: 302FZ56990) executing maintenance item U425. 2. Set a specified original (P/N: 302FZ56990) on the platen. 3. Select the item. <table border="1" data-bbox="333 934 1398 1317"> <thead> <tr> <th>Display</th> <th>Description</th> </tr> </thead> <tbody> <tr> <td>ALL</td> <td>Automatic adjustment using the platen for: original size magnification/ leading edge timing/center line, input gamma, chromatic aberration filter, MTF filter and matrix.</td> </tr> <tr> <td>INPUT</td> <td>Automatic adjustment using the platen for: original size magnification/ leading edge timing/center line.</td> </tr> <tr> <td>C.A.</td> <td>Automatic adjustment using the platen for: chromatic aberration filter.</td> </tr> <tr> <td>MTF</td> <td>Automatic adjustment using the platen for: MTF filter.</td> </tr> <tr> <td>GAMMA</td> <td>Automatic adjustment using the platen for: input gamma.</td> </tr> <tr> <td>MATRIX</td> <td>Automatic adjustment using the platen for: matrix.</td> </tr> </tbody> </table> <ol style="list-style-type: none"> 4. Press the start key. Auto adjustment starts. When automatic adjustment has normally completed, [Complete] is displayed. If a problem occurs during auto adjustment, [ERROR XX] (XX is replaced by an error code) is displayed and operation stops. Should this happen, determine the details of the problem and either repeat the procedure from the beginning, or adjust the remaining items manually by running the corresponding maintenance items. <p>Method: [DP(FACE UP)]</p> <ol style="list-style-type: none"> 1. Measure the leading edge, main scanning, and auxiliary scanning of the specified original (P/N: 302AC68243) and enter the values by executing maintenance item U425. 2. Set a specified original (P/N: 302AC68243) in the DP. Cut the trailing edge of the original. <div data-bbox="485 1644 1222 1899" style="text-align: center;"> </div>	Display	Description	Original to be used for adjustment (P/N)	SCANNER	Automatic adjustment in the scanner section	302FZ56990	DP(FACE UP)	Automatic adjustment in the DP scanning section (first page)	302AC68243	Display	Description	ALL	Automatic adjustment using the platen for: original size magnification/ leading edge timing/center line, input gamma, chromatic aberration filter, MTF filter and matrix.	INPUT	Automatic adjustment using the platen for: original size magnification/ leading edge timing/center line.	C.A.	Automatic adjustment using the platen for: chromatic aberration filter.	MTF	Automatic adjustment using the platen for: MTF filter.	GAMMA	Automatic adjustment using the platen for: input gamma.	MATRIX	Automatic adjustment using the platen for: matrix.
Display	Description	Original to be used for adjustment (P/N)																						
SCANNER	Automatic adjustment in the scanner section	302FZ56990																						
DP(FACE UP)	Automatic adjustment in the DP scanning section (first page)	302AC68243																						
Display	Description																							
ALL	Automatic adjustment using the platen for: original size magnification/ leading edge timing/center line, input gamma, chromatic aberration filter, MTF filter and matrix.																							
INPUT	Automatic adjustment using the platen for: original size magnification/ leading edge timing/center line.																							
C.A.	Automatic adjustment using the platen for: chromatic aberration filter.																							
MTF	Automatic adjustment using the platen for: MTF filter.																							
GAMMA	Automatic adjustment using the platen for: input gamma.																							
MATRIX	Automatic adjustment using the platen for: matrix.																							

Figure 1-3-22

Maintenance item No.	Description																																																										
U411	<p>3. Press [INPUT].</p> <table border="1" data-bbox="331 302 1396 416"> <thead> <tr> <th data-bbox="331 302 635 342">Display</th> <th data-bbox="635 302 1396 342">Description</th> </tr> </thead> <tbody> <tr> <td data-bbox="331 342 635 416">INPUT</td> <td data-bbox="635 342 1396 416">Automatic adjustment of first page using the DP for: original size magnification/leading edge timing/center line.</td> </tr> </tbody> </table> <p>4. Press the start key. Auto adjustment starts. When automatic adjustment has normally completed, [Complete] is displayed. If a problem occurs during auto adjustment, [ERROR XX] (XX is replaced by an error code) is displayed and operation stops. Should this happen, determine the details of the problem and either repeat the procedure from the beginning, or adjust the remaining items manually by running the corresponding maintenance items.</p> <p>Error Codes</p> <table border="1" data-bbox="279 667 1396 1821"> <thead> <tr> <th data-bbox="279 667 448 707">Codes</th> <th data-bbox="448 667 1396 707">Description</th> </tr> </thead> <tbody> <tr><td>ERROR 01</td><td>Black band detection error (scanner leading edge registration)</td></tr> <tr><td>ERROR 02</td><td>Black band detection error (scanner center line)</td></tr> <tr><td>ERROR 03</td><td>Black band detection error (scanner main scanning direction magnification)</td></tr> <tr><td>ERROR 04</td><td>Black band is not detected (scanner leading edge registration)</td></tr> <tr><td>ERROR 05</td><td>Black band is not detected (scanner center line)</td></tr> <tr><td>ERROR 06</td><td>Black band is not detected (scanner main scanning direction magnification)</td></tr> <tr><td>ERROR 07</td><td>Black band is not detected (scanner auxiliary scanning direction magnification)</td></tr> <tr><td>ERROR 08</td><td>Black band is not detected (DP main scanning direction magnification far end)</td></tr> <tr><td>ERROR 09</td><td>Black band is not detected (DP main scanning direction magnification near end)</td></tr> <tr><td>ERROR 0a</td><td>Black band is not detected (DP auxiliary scanning direction magnification leading edge)</td></tr> <tr><td>ERROR 0b</td><td>Black band is not detected (DP auxiliary scanning direction magnification leading edge original check)</td></tr> <tr><td>ERROR 0c</td><td>Black band is not detected (DP auxiliary scanning direction trailing edge)</td></tr> <tr><td>ERROR 0d</td><td>Black band is not detected (DP auxiliary scanning direction trailing edge 2)</td></tr> <tr><td>ERROR 0e</td><td>DMA time out</td></tr> <tr><td>ERROR 0f</td><td>Auxiliary scanning direction magnification error</td></tr> <tr><td>ERROR 10</td><td>Auxiliary scanning direction leading edge detection error</td></tr> <tr><td>ERROR 11</td><td>Auxiliary scanning direction trailing edge detection error</td></tr> <tr><td>ERROR 12</td><td>Auxiliary scanning direction skew 1.5 error</td></tr> <tr><td>ERROR 13</td><td>Maintenance request error</td></tr> <tr><td>ERROR 14</td><td>Main scanning direction center line error</td></tr> <tr><td>ERROR 15</td><td>Main scanning direction skew 1.5 error</td></tr> <tr><td>ERROR 16</td><td>Main scanning direction magnification error</td></tr> <tr><td>ERROR 17</td><td>Service call error</td></tr> <tr><td>ERROR 18</td><td>DP JAM error</td></tr> <tr><td>ERROR 19</td><td>PWB error</td></tr> <tr><td>ERROR 1a</td><td>Original error</td></tr> </tbody> </table> <p>Completion Press the stop key. The screen for selecting a maintenance item is displayed.</p>	Display	Description	INPUT	Automatic adjustment of first page using the DP for: original size magnification/leading edge timing/center line.	Codes	Description	ERROR 01	Black band detection error (scanner leading edge registration)	ERROR 02	Black band detection error (scanner center line)	ERROR 03	Black band detection error (scanner main scanning direction magnification)	ERROR 04	Black band is not detected (scanner leading edge registration)	ERROR 05	Black band is not detected (scanner center line)	ERROR 06	Black band is not detected (scanner main scanning direction magnification)	ERROR 07	Black band is not detected (scanner auxiliary scanning direction magnification)	ERROR 08	Black band is not detected (DP main scanning direction magnification far end)	ERROR 09	Black band is not detected (DP main scanning direction magnification near end)	ERROR 0a	Black band is not detected (DP auxiliary scanning direction magnification leading edge)	ERROR 0b	Black band is not detected (DP auxiliary scanning direction magnification leading edge original check)	ERROR 0c	Black band is not detected (DP auxiliary scanning direction trailing edge)	ERROR 0d	Black band is not detected (DP auxiliary scanning direction trailing edge 2)	ERROR 0e	DMA time out	ERROR 0f	Auxiliary scanning direction magnification error	ERROR 10	Auxiliary scanning direction leading edge detection error	ERROR 11	Auxiliary scanning direction trailing edge detection error	ERROR 12	Auxiliary scanning direction skew 1.5 error	ERROR 13	Maintenance request error	ERROR 14	Main scanning direction center line error	ERROR 15	Main scanning direction skew 1.5 error	ERROR 16	Main scanning direction magnification error	ERROR 17	Service call error	ERROR 18	DP JAM error	ERROR 19	PWB error	ERROR 1a	Original error
Display	Description																																																										
INPUT	Automatic adjustment of first page using the DP for: original size magnification/leading edge timing/center line.																																																										
Codes	Description																																																										
ERROR 01	Black band detection error (scanner leading edge registration)																																																										
ERROR 02	Black band detection error (scanner center line)																																																										
ERROR 03	Black band detection error (scanner main scanning direction magnification)																																																										
ERROR 04	Black band is not detected (scanner leading edge registration)																																																										
ERROR 05	Black band is not detected (scanner center line)																																																										
ERROR 06	Black band is not detected (scanner main scanning direction magnification)																																																										
ERROR 07	Black band is not detected (scanner auxiliary scanning direction magnification)																																																										
ERROR 08	Black band is not detected (DP main scanning direction magnification far end)																																																										
ERROR 09	Black band is not detected (DP main scanning direction magnification near end)																																																										
ERROR 0a	Black band is not detected (DP auxiliary scanning direction magnification leading edge)																																																										
ERROR 0b	Black band is not detected (DP auxiliary scanning direction magnification leading edge original check)																																																										
ERROR 0c	Black band is not detected (DP auxiliary scanning direction trailing edge)																																																										
ERROR 0d	Black band is not detected (DP auxiliary scanning direction trailing edge 2)																																																										
ERROR 0e	DMA time out																																																										
ERROR 0f	Auxiliary scanning direction magnification error																																																										
ERROR 10	Auxiliary scanning direction leading edge detection error																																																										
ERROR 11	Auxiliary scanning direction trailing edge detection error																																																										
ERROR 12	Auxiliary scanning direction skew 1.5 error																																																										
ERROR 13	Maintenance request error																																																										
ERROR 14	Main scanning direction center line error																																																										
ERROR 15	Main scanning direction skew 1.5 error																																																										
ERROR 16	Main scanning direction magnification error																																																										
ERROR 17	Service call error																																																										
ERROR 18	DP JAM error																																																										
ERROR 19	PWB error																																																										
ERROR 1a	Original error																																																										

Maintenance item No.	Description																																								
<p>U425</p> <p>Setting the target</p> <p>Description Enters the lab values that is indicated on the back of the chart (P/N: 302FZ56990) used for adjustment. Also enters the measurement value of the chart (P/N: 302AC68243) used for adjustment.</p> <p>Purpose Performs data input in order to correct for differences in originals during automatic adjustment.</p> <p>Method</p> <ol style="list-style-type: none"> 1. Press the start key. 2. Select the item to be set. 	<table border="1" style="width: 100%;"> <thead> <tr> <th style="text-align: left;">Display</th> <th style="text-align: left;">Description</th> </tr> </thead> <tbody> <tr> <td>CCD</td> <td>Entering the target values of the chart (P/N: 302FZ56990) used for adjustment</td> </tr> <tr> <td>DP</td> <td>Entering the measurement value of the chart (P/N: 302AC68243) used for adjustment</td> </tr> </tbody> </table> <p>Setting: [CCD]</p> <ol style="list-style-type: none"> 1. Select the item to be set. <table border="1" style="width: 100%;"> <thead> <tr> <th style="text-align: left;">Display</th> <th style="text-align: left;">Description</th> </tr> </thead> <tbody> <tr><td>N875</td><td>Setting the N875 patch for the original for adjustment</td></tr> <tr><td>N475</td><td>Setting the N475 patch for the original for adjustment</td></tr> <tr><td>N125</td><td>Setting the N125 patch for the original for adjustment</td></tr> <tr><td>CYAN</td><td>Setting the cyan patch for the original for adjustment</td></tr> <tr><td>MAGENTA</td><td>Setting the magenta patch for the original for adjustment</td></tr> <tr><td>YELLOW</td><td>Setting the yellow patch for the original for adjustment</td></tr> <tr><td>RED</td><td>Setting the red patch for the original for adjustment</td></tr> <tr><td>GREEN</td><td>Setting the green patch for the original for adjustment</td></tr> <tr><td>BLUE</td><td>Setting the blue patch for the original for adjustment</td></tr> <tr><td>ADJUST ORIGINAL</td><td>Setting the main and auxiliary scanning directions</td></tr> </tbody> </table> <ol style="list-style-type: none"> 2. Select the item to be set. <table border="1" style="width: 100%;"> <thead> <tr> <th style="text-align: left;">Display</th> <th style="text-align: left;">Description</th> <th style="text-align: left;">Setting range</th> </tr> </thead> <tbody> <tr> <td>L</td> <td>Setting the L value</td> <td>0.0 to 100.0</td> </tr> <tr> <td>A</td> <td>Setting the A value</td> <td>-200.0 to 200.0</td> </tr> <tr> <td>B</td> <td>Setting the B value</td> <td>-200.0 to 200.0</td> </tr> </tbody> </table> <ol style="list-style-type: none"> 3. Enters the value that is indicated on the back of the chart using the +/- or numeric keys. 4. Press the start key. The value is set. 	Display	Description	CCD	Entering the target values of the chart (P/N: 302FZ56990) used for adjustment	DP	Entering the measurement value of the chart (P/N: 302AC68243) used for adjustment	Display	Description	N875	Setting the N875 patch for the original for adjustment	N475	Setting the N475 patch for the original for adjustment	N125	Setting the N125 patch for the original for adjustment	CYAN	Setting the cyan patch for the original for adjustment	MAGENTA	Setting the magenta patch for the original for adjustment	YELLOW	Setting the yellow patch for the original for adjustment	RED	Setting the red patch for the original for adjustment	GREEN	Setting the green patch for the original for adjustment	BLUE	Setting the blue patch for the original for adjustment	ADJUST ORIGINAL	Setting the main and auxiliary scanning directions	Display	Description	Setting range	L	Setting the L value	0.0 to 100.0	A	Setting the A value	-200.0 to 200.0	B	Setting the B value	-200.0 to 200.0
Display	Description																																								
CCD	Entering the target values of the chart (P/N: 302FZ56990) used for adjustment																																								
DP	Entering the measurement value of the chart (P/N: 302AC68243) used for adjustment																																								
Display	Description																																								
N875	Setting the N875 patch for the original for adjustment																																								
N475	Setting the N475 patch for the original for adjustment																																								
N125	Setting the N125 patch for the original for adjustment																																								
CYAN	Setting the cyan patch for the original for adjustment																																								
MAGENTA	Setting the magenta patch for the original for adjustment																																								
YELLOW	Setting the yellow patch for the original for adjustment																																								
RED	Setting the red patch for the original for adjustment																																								
GREEN	Setting the green patch for the original for adjustment																																								
BLUE	Setting the blue patch for the original for adjustment																																								
ADJUST ORIGINAL	Setting the main and auxiliary scanning directions																																								
Display	Description	Setting range																																							
L	Setting the L value	0.0 to 100.0																																							
A	Setting the A value	-200.0 to 200.0																																							
B	Setting the B value	-200.0 to 200.0																																							

Maintenance item No.	Description
U425	<p>Setting: [ADJUST ORIGINAL]</p> <ol style="list-style-type: none"> 1. Measure the distance from the left edge to the black belt (a) of the original at A, B and C. Measurement procedure 1) Measure the distance from the edge to the black belt (a) of the original at A (35 mm from the leading edge), B (110 mm from the leading edge) and C (185 mm from the leading edge), respectively. 2) Apply the following formula for the values obtained: $((A + C) / 2 + B) / 2$ 2. Enter the values solved using the +/- keys in [MAIN ADJ]. 3. Press the start key. The value is set. 4. Measure the distance from the leading edge to the black belt (b) of the original at D, E and F. Measurement procedure 1) Measure the length from the edge to the black belt (b) of the original at D (30 mm from the left edge), E (148.5 mm from the left edge) and F (267 mm from the left edge), respectively. 2) Apply the following formula for the values obtained: $((D + F) / 2 + E) / 2$ 5. Enter the values solved using the +/- keys in [SUB LEAD ADJ]. 6. Press the start key. The value is set. 7. Measure the length (G) from the leading edge of the black belt (b) to the bottom of the N475 patch of the original. 8. Enter the measured value using the +/- keys in [SUB TAIL ADJ]. 9. Press the start key. The value is set. 10. To return to the screen for selecting an item, press the stop key.  <div style="border: 1px solid black; padding: 5px; width: fit-content; margin-left: auto; margin-right: auto;"> <p>[MAIN ADJ] = $((A + C) / 2 + B) / 2$</p> <p>[SUB LEAD ADJ] = $((D + F) / 2 + E) / 2$</p> <p>[SUB TAIL ADJ] = G</p> </div> <p style="text-align: center;">Original for adjustment (P/N: 302FZ56990)</p>

Figure 1-3-23

Maintenance item No.	Description
U425	<p>Setting: [DP]</p> <ol style="list-style-type: none"> 1. Measure the distance from the leading edge to the black belt (inside) of the original at A. 2. Enter the measured value using the +/- keys in [LEAD]. 3. Measure the distance from the left edge to the black belt (inside) of the original at B. 4. Enter the measured value using the +/- keys in [MAIN SCAN]. 5. Measure the distance from the black belt of leading edge (inside) to the black belt of trailing edge (inside) of the original at C. 6. Enter the measured value using the +/- keys in [SUB SCAN]. 7. Press the start key. The value is set. <div style="text-align: center;">  <p>The diagram shows a rectangular object with a thick black border. Three measurement points are indicated: 'A' is a vertical double-headed arrow on the right side, measuring the distance from the top edge to the inner edge of the right black belt; 'B' is a horizontal double-headed arrow at the top, measuring the distance from the left edge to the inner edge of the top black belt; 'C' is a vertical double-headed arrow in the center, measuring the distance between the inner edges of the left and right black belts.</p> </div> <p>Original for adjustment (P/N: 302AC68243)</p> <p>Figure 1-3-24</p> <p>Completion Press the stop key. The screen for selecting a maintenance item No. is displayed.</p>

Maintenance item No.	Description																																																																				
U470	<p>Setting the JPEG compression ratio</p> <p>Description Sets the compression ratio for JPEG images in each image quality mode.</p> <p>Purpose To change the setting in accordance with the image that the user is copying. For example, in order to soften the coarseness of the image when making copies at over 200% magnification, change the level of compression by raising the value. Lowering the value will increase the compression and thereby lower the image quality; Raising the value will increase image quality but lower the image processing speed.</p> <p>Method</p> <ol style="list-style-type: none"> 1. Press the start key. 2. Select the item to be set. The setting screen for the selected item is displayed. <table border="1" data-bbox="333 613 1398 781"> <thead> <tr> <th>Display</th> <th>Description</th> </tr> </thead> <tbody> <tr> <td>System</td> <td>Compression ratio for temporary storage in system</td> </tr> <tr> <td>Copy</td> <td>Compression ratio for copying</td> </tr> <tr> <td>Send</td> <td>Compression ratio for sending</td> </tr> </tbody> </table> <p>Setting: [System]</p> <ol style="list-style-type: none"> 1. Select the item to be set. 2. Change the setting value using the +/- or numeric keys. <table border="1" data-bbox="333 909 1398 1032"> <thead> <tr> <th>Display</th> <th>Description</th> <th>Setting range</th> <th>Initial setting</th> </tr> </thead> <tbody> <tr> <td>Y</td> <td>Brightness</td> <td>1 to 100</td> <td>90</td> </tr> <tr> <td>C</td> <td>Color differential</td> <td>1 to 100</td> <td>90</td> </tr> </tbody> </table> <ol style="list-style-type: none"> 3. Press the start key. The value is set. <p>Setting: [Copy]</p> <ol style="list-style-type: none"> 1. Select the item to be set. 2. Change the setting value using the +/- or numeric keys. <table border="1" data-bbox="333 1193 1398 1402"> <thead> <tr> <th>Display</th> <th>Description</th> <th>Setting range</th> <th>Initial setting</th> </tr> </thead> <tbody> <tr> <td>Text Y</td> <td>Brightness in the text mode</td> <td>1 to 100</td> <td>90</td> </tr> <tr> <td>Text C</td> <td>Color differential in the text mode</td> <td>1 to 100</td> <td>90</td> </tr> <tr> <td>Photo Y</td> <td>Brightness in the photo mode</td> <td>1 to 100</td> <td>90</td> </tr> <tr> <td>Photo C</td> <td>Color differential in the photo mode</td> <td>1 to 100</td> <td>90</td> </tr> </tbody> </table> <ol style="list-style-type: none"> 3. Press the start key. The value is set. <p>Setting: [Send]</p> <ol style="list-style-type: none"> 1. Select [Text], [Photo] or [HC-PDF]. 2. Select the item to be set. 3. Change the setting value using the +/- or numeric keys. <table border="1" data-bbox="333 1592 1398 1912"> <thead> <tr> <th>Display</th> <th>Description</th> <th>Setting range</th> <th>Initial setting</th> </tr> </thead> <tbody> <tr> <td>Text Y (1) to (5)</td> <td>Brightness in the text mode</td> <td>1 to 100</td> <td>30/40/51/70/90</td> </tr> <tr> <td>Text C (1) to (5)</td> <td>Color differential in the text mode</td> <td>1 to 100</td> <td>30/40/51/70/90</td> </tr> <tr> <td>Photo Y (1) to (5)</td> <td>Brightness in the photo mode</td> <td>1 to 100</td> <td>30/40/51/70/90</td> </tr> <tr> <td>Photo C (1) to (5)</td> <td>Color differential in the photo mode</td> <td>1 to 100</td> <td>30/40/51/70/90</td> </tr> <tr> <td>HC-PDF Y (1) to (3)</td> <td>Brightness of high compression PDF</td> <td>1 to 100</td> <td>15/25/60</td> </tr> <tr> <td>HC-PDF C (1) to (3)</td> <td>Color differential of high compression PDF</td> <td>1 to 100</td> <td>15/25/60</td> </tr> </tbody> </table> <ol style="list-style-type: none"> 4. Press the start key. The value is set. 	Display	Description	System	Compression ratio for temporary storage in system	Copy	Compression ratio for copying	Send	Compression ratio for sending	Display	Description	Setting range	Initial setting	Y	Brightness	1 to 100	90	C	Color differential	1 to 100	90	Display	Description	Setting range	Initial setting	Text Y	Brightness in the text mode	1 to 100	90	Text C	Color differential in the text mode	1 to 100	90	Photo Y	Brightness in the photo mode	1 to 100	90	Photo C	Color differential in the photo mode	1 to 100	90	Display	Description	Setting range	Initial setting	Text Y (1) to (5)	Brightness in the text mode	1 to 100	30/40/51/70/90	Text C (1) to (5)	Color differential in the text mode	1 to 100	30/40/51/70/90	Photo Y (1) to (5)	Brightness in the photo mode	1 to 100	30/40/51/70/90	Photo C (1) to (5)	Color differential in the photo mode	1 to 100	30/40/51/70/90	HC-PDF Y (1) to (3)	Brightness of high compression PDF	1 to 100	15/25/60	HC-PDF C (1) to (3)	Color differential of high compression PDF	1 to 100	15/25/60
Display	Description																																																																				
System	Compression ratio for temporary storage in system																																																																				
Copy	Compression ratio for copying																																																																				
Send	Compression ratio for sending																																																																				
Display	Description	Setting range	Initial setting																																																																		
Y	Brightness	1 to 100	90																																																																		
C	Color differential	1 to 100	90																																																																		
Display	Description	Setting range	Initial setting																																																																		
Text Y	Brightness in the text mode	1 to 100	90																																																																		
Text C	Color differential in the text mode	1 to 100	90																																																																		
Photo Y	Brightness in the photo mode	1 to 100	90																																																																		
Photo C	Color differential in the photo mode	1 to 100	90																																																																		
Display	Description	Setting range	Initial setting																																																																		
Text Y (1) to (5)	Brightness in the text mode	1 to 100	30/40/51/70/90																																																																		
Text C (1) to (5)	Color differential in the text mode	1 to 100	30/40/51/70/90																																																																		
Photo Y (1) to (5)	Brightness in the photo mode	1 to 100	30/40/51/70/90																																																																		
Photo C (1) to (5)	Color differential in the photo mode	1 to 100	30/40/51/70/90																																																																		
HC-PDF Y (1) to (3)	Brightness of high compression PDF	1 to 100	15/25/60																																																																		
HC-PDF C (1) to (3)	Color differential of high compression PDF	1 to 100	15/25/60																																																																		

Maintenance item No.	Description														
<p>U470</p>	<p>Supplement While this maintenance item is being executed, copying from an original is available in interrupt copying mode (which is activated by pressing the system menu key).</p> <p>Completion Press the stop key. The screen for selecting a maintenance item No. is displayed.</p>														
<p>U473</p>	<p>Adjusting laser power output Description Adjusts the laser output power Purpose Performed when the quality of dots, lines or low density has dropped.</p> <p>Method</p> <ol style="list-style-type: none"> 1. Press the start key. 2. Select [Set Density (EmitTime/Dot). 3. Select the item. <table border="1" data-bbox="333 779 1398 987"> <thead> <tr> <th>Display</th> <th>Description</th> </tr> </thead> <tbody> <tr> <td>0 (100%)</td> <td>LSU laser output (100%)</td> </tr> <tr> <td>1 (90%)</td> <td>LSU laser output (90%)</td> </tr> <tr> <td>2 (80%)</td> <td>LSU laser output (80%)</td> </tr> <tr> <td>3 (70%)</td> <td>LSU laser output (70%)</td> </tr> </tbody> </table> <p>Initial setting: 0</p> <ol style="list-style-type: none"> 4. Press the start key. The setting is set. <p>Completion Press the stop key. The screen for selecting a maintenance item No. is displayed.</p>	Display	Description	0 (100%)	LSU laser output (100%)	1 (90%)	LSU laser output (90%)	2 (80%)	LSU laser output (80%)	3 (70%)	LSU laser output (70%)				
Display	Description														
0 (100%)	LSU laser output (100%)														
1 (90%)	LSU laser output (90%)														
2 (80%)	LSU laser output (80%)														
3 (70%)	LSU laser output (70%)														
<p>U485</p>	<p>Setting the image processing mode Description Sets the detection level for scanning printed matter outputted with the confidential document guard function. Also, sets the process PDF images are rotated. Purpose To change the detection level when the confidential document guard is not printed well for detection in scanning. Also, changes the process of how PDF images are rotated.</p> <p>Method</p> <ol style="list-style-type: none"> 1. Press the start key. 2. Select the item. <table border="1" data-bbox="333 1482 1398 1610"> <thead> <tr> <th>Display</th> <th>Description</th> </tr> </thead> <tbody> <tr> <td>Conf. Doc. Detection</td> <td>Confidential document guard detection level</td> </tr> <tr> <td>PDF Rotate</td> <td>Processing the rotation of PDF images</td> </tr> </tbody> </table> <p>Setting: [Conf. Doc. Detection]</p> <ol style="list-style-type: none"> 1. Change the setting value using +/- or numeric keys. <table border="1" data-bbox="333 1711 1398 1823"> <thead> <tr> <th>Display</th> <th>Description</th> <th>Setting range</th> <th>Initial setting</th> </tr> </thead> <tbody> <tr> <td>Conf. Doc. Detection</td> <td>Confidential document guard detection level</td> <td>1 to 5</td> <td>1</td> </tr> </tbody> </table> <p>A smaller value raises the detection sensitivity but increases the possibility of false detection. A larger value lowers the detection sensitivity but decreases the possibility of false detection.</p> <ol style="list-style-type: none"> 2. Press the start key. The value is set. 	Display	Description	Conf. Doc. Detection	Confidential document guard detection level	PDF Rotate	Processing the rotation of PDF images	Display	Description	Setting range	Initial setting	Conf. Doc. Detection	Confidential document guard detection level	1 to 5	1
Display	Description														
Conf. Doc. Detection	Confidential document guard detection level														
PDF Rotate	Processing the rotation of PDF images														
Display	Description	Setting range	Initial setting												
Conf. Doc. Detection	Confidential document guard detection level	1 to 5	1												

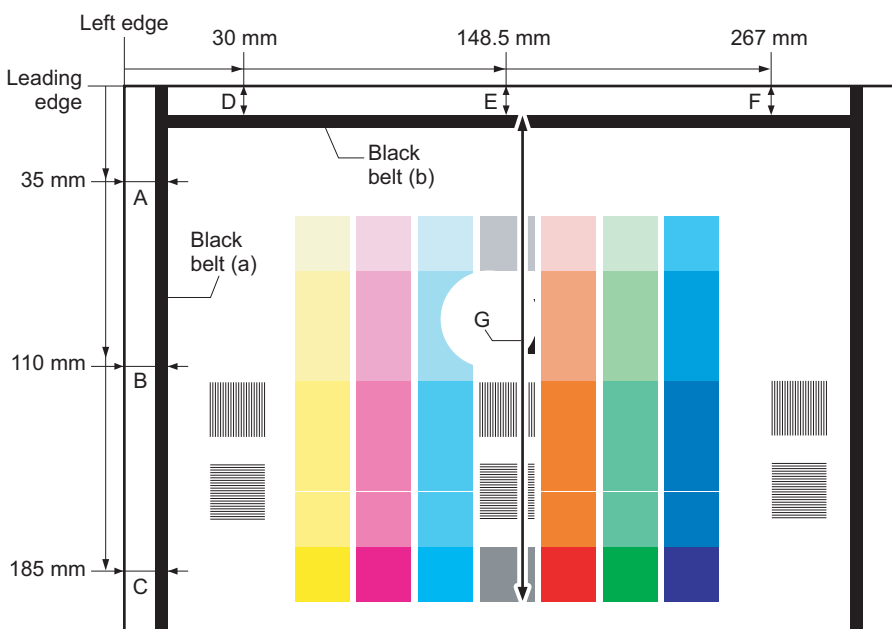
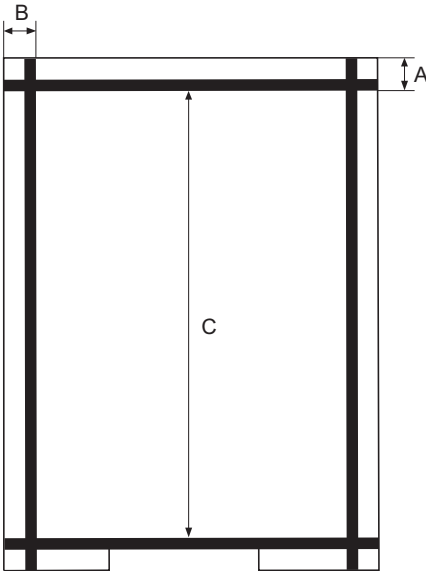
Maintenance item No.	Description										
U485	<p>Setting: [PDF Rotate]</p> <ol style="list-style-type: none"> Change the setting value using +/- or numeric keys. <table border="1" data-bbox="335 331 1396 454"> <thead> <tr> <th>Display</th> <th>Description</th> </tr> </thead> <tbody> <tr> <td>0</td> <td>Assigns the image rotation with the internal parameter</td> </tr> <tr> <td>1</td> <td>Assigns the image rotation with the actual image</td> </tr> </tbody> </table> <p>Initial setting: 0</p> <ol style="list-style-type: none"> Press the start key. The value is set. <p>Completion Press the stop key. The screen for selecting a maintenance item No. is displayed.</p>	Display	Description	0	Assigns the image rotation with the internal parameter	1	Assigns the image rotation with the actual image				
Display	Description										
0	Assigns the image rotation with the internal parameter										
1	Assigns the image rotation with the actual image										
U510	<p>Setting the enterprise mode</p> <p>Description Sets whether or not the application function is enabled.</p> <p>Purpose According to user request, changes the setting.</p> <p>Setting</p> <ol style="list-style-type: none"> Press the start key. Select [MODE1]. Select the item. <table border="1" data-bbox="335 918 1396 1126"> <thead> <tr> <th>Display</th> <th>Description</th> </tr> </thead> <tbody> <tr> <td>ON</td> <td>Application function is enabled</td> </tr> <tr> <td>OFF</td> <td>Application function is disabled</td> </tr> <tr> <td>INSTALL</td> <td>Executing the install</td> </tr> <tr> <td>UNINSTALL</td> <td>Executing the uninstall</td> </tr> </tbody> </table> <ol style="list-style-type: none"> Press the start key. The setting is set. <p>Method: [INSTALL]</p> <ol style="list-style-type: none"> Insert the USB memory that contains the application into the USB memory slot on the machine. Turn the main power switch on. Enter the maintenance item. Press the start key. Select [INSTALL]. Press the start key. Installation of application is started. When normally completed, [Complete] is displayed. <p>Completion Press the stop key. The screen for selecting a maintenance item No. is displayed.</p>	Display	Description	ON	Application function is enabled	OFF	Application function is disabled	INSTALL	Executing the install	UNINSTALL	Executing the uninstall
Display	Description										
ON	Application function is enabled										
OFF	Application function is disabled										
INSTALL	Executing the install										
UNINSTALL	Executing the uninstall										

Maintenance item No.	Description														
U901	<p>Checking/clearing copy counts by paper feed locations</p> <p>Description Displays or clears copy counts by paper feed locations.</p> <p>Purpose To check the time to replace consumable parts. Also to clear the counts after replacing the consumable parts.</p> <p>Method</p> <ol style="list-style-type: none"> 1. Press the start key. The counts by paper feed locations are displayed. <table border="1" data-bbox="335 506 1398 797"> <thead> <tr> <th>Display</th> <th>Description</th> </tr> </thead> <tbody> <tr> <td>MP TRAY</td> <td>MP tray</td> </tr> <tr> <td>CASSETTE 1</td> <td>Cassette 1</td> </tr> <tr> <td>CASSETTE 2</td> <td>Cassette 2</td> </tr> <tr> <td>CASSETTE 3</td> <td>Cassette 3 (optional paper feeder)</td> </tr> <tr> <td>CASSETTE 4</td> <td>Cassette 4 (optional paper feeder)</td> </tr> <tr> <td>DUPLEX</td> <td>Duplex unit</td> </tr> </tbody> </table> <p>When an optional paper feed device is not installed, the corresponding count is not displayed.</p> <p>Clearing</p> <ol style="list-style-type: none"> 1. Select the counts to be cleared. CASSETTE 3 and CASSETTE 4 cannot be cleared. 2. Select the counts for all and press [ALL CLEAR]. 3. Press the start key. The counts is cleared. <p>Completion Press the stop key. The screen for selecting a maintenance item No. is displayed.</p>	Display	Description	MP TRAY	MP tray	CASSETTE 1	Cassette 1	CASSETTE 2	Cassette 2	CASSETTE 3	Cassette 3 (optional paper feeder)	CASSETTE 4	Cassette 4 (optional paper feeder)	DUPLEX	Duplex unit
Display	Description														
MP TRAY	MP tray														
CASSETTE 1	Cassette 1														
CASSETTE 2	Cassette 2														
CASSETTE 3	Cassette 3 (optional paper feeder)														
CASSETTE 4	Cassette 4 (optional paper feeder)														
DUPLEX	Duplex unit														
U903	<p>Checking/clearing the paper jam counts</p> <p>Description Displays or clears the jam counts by jam locations.</p> <p>Purpose To check the paper jam status. Also to clear the jam counts after replacing consumable parts.</p> <p>Method</p> <ol style="list-style-type: none"> 1. Press the start key. 2. Select the item. The screen for selecting an item is displayed. <table border="1" data-bbox="335 1379 1398 1505"> <thead> <tr> <th>Display</th> <th>Description</th> </tr> </thead> <tbody> <tr> <td>Count</td> <td>Displays/clears the jam counts</td> </tr> <tr> <td>Total Count</td> <td>Displays the total jam counts</td> </tr> </tbody> </table> <p>Method: [Count]</p> <ol style="list-style-type: none"> 1. Select [Count]. The count of jam code by type is displayed. Codes for which the count value is 0 are not displayed. 2. Change the screen using the cursor up/down keys. 3. Select the counts for all jam codes and press [ALL CLEAR]. The individual counter cannot be cleared. 4. Press the start key. The count is cleared. <p>Method: [Total Count]</p> <ol style="list-style-type: none"> 1. Select [Total Count]. The total number of jam code by type is displayed. 2. Change the screen using the cursor up/down keys. The total number of jam count cannot be cleared. <p>Completion Press the stop key. The screen for selecting a maintenance item No. is displayed.</p>	Display	Description	Count	Displays/clears the jam counts	Total Count	Displays the total jam counts								
Display	Description														
Count	Displays/clears the jam counts														
Total Count	Displays the total jam counts														

Maintenance item No.	Description						
U904	<p>Checking/clearing the service call counts</p> <p>Description Displays or clears the service call code counts by types.</p> <p>Purpose To check the service call code status by types. Also to clear the service call code counts after replacing consumable parts.</p> <p>Method</p> <ol style="list-style-type: none"> 1. Press the start key. 2. Press the start key. The screen for selecting an item is displayed. <table border="1" data-bbox="333 564 1398 689"> <thead> <tr> <th data-bbox="339 564 636 607">Display</th> <th data-bbox="636 564 1391 607">Description</th> </tr> </thead> <tbody> <tr> <td data-bbox="339 607 636 645">Count</td> <td data-bbox="636 607 1391 645">Displays/clears the call for service counts</td> </tr> <tr> <td data-bbox="339 645 636 689">Total Count</td> <td data-bbox="636 645 1391 689">Displays the total call for service counts</td> </tr> </tbody> </table> <p>Method: [Count]</p> <ol style="list-style-type: none"> 1. Select [Count]. The count for service call detection by type is displayed. Codes for which the count value is 0 are not displayed. 2. Change the screen using the cursor up/down keys. 3. Select the counts for all service call codes and press [ALL CLEAR]. The individual counter cannot be cleared. 4. Press the start key. The count is cleared. <p>Method: [Total Count]</p> <ol style="list-style-type: none"> 1. Select [Total Count]. The total number of service call counts by type is displayed. 2. Change the screen using the cursor up/down keys. The total number of service call count cannot be cleared. <p>Completion Press the stop key. The screen for selecting a maintenance item No. is displayed.</p>	Display	Description	Count	Displays/clears the call for service counts	Total Count	Displays the total call for service counts
Display	Description						
Count	Displays/clears the call for service counts						
Total Count	Displays the total call for service counts						

Maintenance item No.	Description																		
<p>U905</p>	<p>Checking/clearing counts by optional devices</p> <p>Description Displays the counts of DP or finisher.</p> <p>Purpose To check the use of DP and finisher.</p> <p>Method</p> <ol style="list-style-type: none"> 1. Press the start key. 2. Select the device, the count of which is to be checked. 3. Press the start key. The count of the selected device is displayed. <table border="1" data-bbox="333 564 1398 689"> <thead> <tr> <th>Display</th> <th>Description</th> </tr> </thead> <tbody> <tr> <td>DP</td> <td>Counts of optional DP</td> </tr> <tr> <td>FINISHER</td> <td>Counts of optional document finisher or built-in finisher</td> </tr> </tbody> </table> <p>DP</p> <table border="1" data-bbox="333 770 1398 896"> <thead> <tr> <th>Display</th> <th>Description</th> </tr> </thead> <tbody> <tr> <td>ADP</td> <td>No. of single-sided originals that has passed through the DP</td> </tr> <tr> <td>RADP</td> <td>No. of double-sided originals that has passed through the DP</td> </tr> </tbody> </table> <p>Document finisher/Built-in finisher</p> <table border="1" data-bbox="333 969 1398 1095"> <thead> <tr> <th>Display</th> <th>Description</th> </tr> </thead> <tbody> <tr> <td>CP CNT</td> <td>No. of copies that has passed</td> </tr> <tr> <td>STAPLE</td> <td>Frequency the stapler has been activated</td> </tr> </tbody> </table> <p>Completion Press the stop key. The screen for selecting a maintenance item No. is displayed.</p>	Display	Description	DP	Counts of optional DP	FINISHER	Counts of optional document finisher or built-in finisher	Display	Description	ADP	No. of single-sided originals that has passed through the DP	RADP	No. of double-sided originals that has passed through the DP	Display	Description	CP CNT	No. of copies that has passed	STAPLE	Frequency the stapler has been activated
Display	Description																		
DP	Counts of optional DP																		
FINISHER	Counts of optional document finisher or built-in finisher																		
Display	Description																		
ADP	No. of single-sided originals that has passed through the DP																		
RADP	No. of double-sided originals that has passed through the DP																		
Display	Description																		
CP CNT	No. of copies that has passed																		
STAPLE	Frequency the stapler has been activated																		
<p>U906</p>	<p>Resetting partial operation control</p> <p>Description Resets the service call code for partial operation control.</p> <p>Purpose To be reset after partial operation is performed due to problems in the cassettes or other sections, and the related parts are serviced.</p> <p>Method</p> <ol style="list-style-type: none"> 1. Press the start key. 2. Press [Execute]. 3. Press the start key to reset partial operation control. 4. Turn the main power switch off and on. 																		

Maintenance item No.	Description
U908	<p>Checking the total counter value</p> <p>Description Displays the total counter value.</p> <p>Purpose To check the total counter value.</p> <p>Method</p> <ol style="list-style-type: none"> 1. Press the start key. The screen for total count value is displayed. <p>Completion Press the stop key. The screen for selecting a maintenance item No. is displayed.</p>
U910	<p>Clearing the black ratio data</p> <p>Description Clears the accumulated black ratio data for A4 sheet.</p> <p>Purpose To clear data as required at times such as during maintenance service.</p> <p>Method</p> <ol style="list-style-type: none"> 1. Press the start key. 2. Select [EXCUTE]. 3. Press the start key. The accumulated black ratio data is cleared. <p>Completion Press the stop key. The screen for selecting a maintenance item No. is displayed.</p>
U911	<p>Checking copy counts by paper sizes</p> <p>Description Displays the paper feed counts by paper sizes.</p> <p>Purpose To check the counts after replacing consumable parts.</p> <p>Method</p> <ol style="list-style-type: none"> 1. Press the start key. The screen for the paper feed counts by paper size is displayed. <p>Completion Press the stop/clear key. The screen for selecting a maintenance item No. is displayed.</p>

Maintenance item No.	Description																																				
<p>U917</p>	<p>Setting backup data reading/writing</p> <p>Description Retrieves the backup data to a USB memory from the machine; or writes the data from the USB memory to the machine.</p> <p>Purpose To store and write data when replacing the HDD.</p> <p>Method</p> <ol style="list-style-type: none"> 1. Press the power key on the operation panel, and after verifying the main power indicator has gone off, switch off the main power switch. 2. Insert USB memory in USB memory slot. 3. Turn the main power switch on. 4. Enter the maintenance item. 5. Press the start key. 6. Select [Export] or [Import]. <table border="1" data-bbox="333 707 1398 835"> <thead> <tr> <th>Display</th> <th>Description</th> </tr> </thead> <tbody> <tr> <td>Export</td> <td>Retrieving from the machine to a USB memory</td> </tr> <tr> <td>Import</td> <td>Writing data from the USB memory to the machine</td> </tr> </tbody> </table> <ol style="list-style-type: none"> 7. Select the item. <table border="1" data-bbox="333 884 1398 1420"> <thead> <tr> <th>Display</th> <th>Description</th> <th>Depending data*1</th> </tr> </thead> <tbody> <tr> <td>Address Book</td> <td>Address book</td> <td>-</td> </tr> <tr> <td>Job Acct.</td> <td>Job accounting</td> <td>-</td> </tr> <tr> <td>FAX Forward</td> <td>FAX transfer information</td> <td>Job accounting, user management and document box information</td> </tr> <tr> <td>One Touch</td> <td>Information on one-touch</td> <td>Address book</td> </tr> <tr> <td>User</td> <td>User managements</td> <td>Job accounting</td> </tr> <tr> <td>Shortcut</td> <td>Shortcut information</td> <td>Job accountings, user managements and document box information</td> </tr> <tr> <td>Document Box</td> <td>Document box information</td> <td>Job accountings and user managements</td> </tr> <tr> <td>Program</td> <td>Program information</td> <td>Job accountings, user managements and document box information</td> </tr> <tr> <td>ADDRESS BOOK ONE TOUCH*2</td> <td>Address book and Information on one-touch</td> <td>Address book and Information on one-touch</td> </tr> </tbody> </table> <p>*1: Since data are dependent with each other, data other than those assigned are also retrieved or written in. *2: When ADDRESS BOOK ONE TOUCH is selected, editing with the Set up tool is not possible, however, Import/Export in high speed mode is possible.</p> <ol style="list-style-type: none"> 8. Press the start key. Starts reading or writing. The progress of selected item is displayed in %. When an error occurs, the operation is canceled and an error code is displayed (see page 1-3-89). 9. When normally completed, [Finished] is displayed. 10. Turn the main power switch off and on after completing writing when selecting [Import]. <p>Completion Press the stop key. The screen for selecting a maintenance item No. is displayed.</p>	Display	Description	Export	Retrieving from the machine to a USB memory	Import	Writing data from the USB memory to the machine	Display	Description	Depending data*1	Address Book	Address book	-	Job Acct.	Job accounting	-	FAX Forward	FAX transfer information	Job accounting, user management and document box information	One Touch	Information on one-touch	Address book	User	User managements	Job accounting	Shortcut	Shortcut information	Job accountings, user managements and document box information	Document Box	Document box information	Job accountings and user managements	Program	Program information	Job accountings, user managements and document box information	ADDRESS BOOK ONE TOUCH*2	Address book and Information on one-touch	Address book and Information on one-touch
Display	Description																																				
Export	Retrieving from the machine to a USB memory																																				
Import	Writing data from the USB memory to the machine																																				
Display	Description	Depending data*1																																			
Address Book	Address book	-																																			
Job Acct.	Job accounting	-																																			
FAX Forward	FAX transfer information	Job accounting, user management and document box information																																			
One Touch	Information on one-touch	Address book																																			
User	User managements	Job accounting																																			
Shortcut	Shortcut information	Job accountings, user managements and document box information																																			
Document Box	Document box information	Job accountings and user managements																																			
Program	Program information	Job accountings, user managements and document box information																																			
ADDRESS BOOK ONE TOUCH*2	Address book and Information on one-touch	Address book and Information on one-touch																																			

Maintenance item No.	Description			
U917	Error Codes			
	Codes	Description	Codes	Description
	321e0001	Parameter error	321e002f	Box open error
	321e0002	File write error	321e0030	Box close error
	321e0003	File initialization error	321e0031	Box creation error
	321e0004	File error	321e0032	Box creation error
	321e0005	Processing error	321e0033	Box deletion error
	321e0006	Address book clear error (contact)	321e0034	Box movement error
	321e0007	Address book open error (contact)	321e0035	Fax memory directory creation error
	321e0008	Address book list error (contact)	321e0036	Fax memory error in writing
	321e0009	Address book list error (contact)	321e0037	Fax memory error in reading
	321e000a	Address book clear error (group)	321e0038	Shortcut error in writing
	321e000b	Address book open error (group)	321e0039	Shortcut error in reading
	321e000c	Address book list error (group)	321e003a	Program error in writing
	321e000d	Address book list error (group)	321e003b	Program error in reading
	321e000e	One-touch open error	321e003c	Address/One Touch directory creation error
	321e000f	One-touch list error	321e003d	Address/One Touch error in writing
	321e0010	One-touch list error	321e003e	Address/One Touch error in reading
	321e0011	Job accounting clear error	321e003f	File reading error
	321e0012	Job accounting file open error	321e0040	File writing error
	321e0013	Job accounting file open error	321e0041	Data mismatch
	321e0014	Job accounting error in writing	321e0042	Log file open error
	321e0015	Job accounting list error	321e0043	Log file error in writing
	321e0016	Job accounting list error	321e0044	Directory open error
	321e0017	User managements backup error	321e0045	Directory error in reading
	321e0018	User managements clear error	321d0000	Unspecified error
	321e0019	User managements file open error	321d0001	HDD unavailable
	321e001a	User managements file open error	321d0002	USB memory is not inserted
	321e001b	User managements file open error	321d0003	File for writing is not found in the USB
	321e001c	User managements error in writing	321d0004	File for reading is not found in the HDD
	321e001d	User managements list error	321d0005	USB error in writing
	321e001e	User managements list error	321d0006	USB error in reading
	321e001f	User managements list error	321d0007	USB unmount error
	321e0020	User managements list error	321d0008	File rename error
	321e0021	User managements file open error	321d0009	File open error
	321e0022	User managements error	321d000a	File close error
	321e0023	User managements error	321d000b	File reading error
	321e0024	User managements file open error	321d000c	File writing error
	321e0025	User managements error	321d000d	File copy error
	321e0026	User managements file open error	321d000e	File compressed error
	321e0027	User managements error	321d000f	File decompressed error
	321e0028	Box file open error	321d0010	Directory open error
	321e0029	Box error in writing	321d0011	Directory creation error
	321e002a	Box error in reading	321d0012	File writing error
	321e002b	Box list error	321d0013	File reading error
	321e002c	Box list error	321d0014	File deletion error
	321e002d	Box error	321d0015	Log file copy error to the USB
	321e002e	Box error		

Maintenance item No.	Description								
<p>U920</p>	<p>Checking the copy counts</p> <p>Description Checks the copy counts.</p> <p>Purpose To check the copy counts.</p> <p>Method</p> <ol style="list-style-type: none"> 1. Press the start key. The current counts are displayed. <table border="1" data-bbox="333 506 1398 674"> <thead> <tr> <th>Display</th> <th>Description</th> </tr> </thead> <tbody> <tr> <td>Copy Count</td> <td>Count value of copy</td> </tr> <tr> <td>Printer Count</td> <td>Count value of printer</td> </tr> <tr> <td>Fax Count</td> <td>Count value of fax</td> </tr> </tbody> </table> <p>Completion Press the stop key. The screen for selecting a maintenance item No. is displayed.</p>	Display	Description	Copy Count	Count value of copy	Printer Count	Count value of printer	Fax Count	Count value of fax
Display	Description								
Copy Count	Count value of copy								
Printer Count	Count value of printer								
Fax Count	Count value of fax								
<p>U927</p>	<p>Clearing the all copy counts and machine life counts (one time only)</p> <p>Description Resets all of the counts back to zero.</p> <p>Supplement The total account counter and the machine life counter can be cleared only once if all count values are 1000 or less.</p> <p>Method</p> <ol style="list-style-type: none"> 1. Press the start key. 2. Press [EXECUTE]. 3. Press the start key. All copy counts and machine life counts are cleared. [CAN NOT EXECUTE] is displayed if the count cannot be cleared. <p>Completion Press the stop key. The screen for selecting a maintenance item No. is displayed.</p>								
<p>U928</p>	<p>Checking machine life counts</p> <p>Description Displays the machine life counts.</p> <p>Purpose To check the machine life counts.</p> <p>Method</p> <ol style="list-style-type: none"> 1. Press the start key. The current machine life counts is displayed. <p>Completion Press the stop key. The screen for selecting a maintenance item No. is displayed.</p>								

Maintenance item No.	Description						
U931	<p>Setting the automatic toner install</p> <p>Description Sets automatic toner installation on or off when power is turned on.</p> <p>Purpose Changed to off when deactivating automatic toner installation.</p> <p>Setting</p> <ol style="list-style-type: none"> 1. Press the start key. 2. Select ON or OFF. <table border="1" data-bbox="333 535 1398 660"> <thead> <tr> <th>Display</th> <th>Description</th> </tr> </thead> <tbody> <tr> <td>ON</td> <td>Automatic toner install function ON</td> </tr> <tr> <td>OFF</td> <td>Automatic toner install function OFF</td> </tr> </tbody> </table> <p>Initial setting: OFF</p> <ol style="list-style-type: none"> 3. Press the start key. The setting is set. 4. The machine automatically returns to the same status as when the power is turned on. 	Display	Description	ON	Automatic toner install function ON	OFF	Automatic toner install function OFF
Display	Description						
ON	Automatic toner install function ON						
OFF	Automatic toner install function OFF						
U935	<p>Relay board maintenance</p> <p>Description Sets the mode when call for service (C0060) occurs.</p> <p>Purpose Sets the machine status temporarily when call for service (C0060) occurs. However, after the setting, call for service (C0060) occurs again when progress of period.</p> <p>Setting</p> <ol style="list-style-type: none"> 1. Press the start key. 2. Select the item. <table border="1" data-bbox="333 1095 1398 1220"> <thead> <tr> <th>Display</th> <th>Description</th> </tr> </thead> <tbody> <tr> <td>MODE0</td> <td>Setting mode: OFF</td> </tr> <tr> <td>MODE1</td> <td>Setting mode: ON (Usable up to three times of use)</td> </tr> </tbody> </table> <p>Initial setting: MODE0</p> <ol style="list-style-type: none"> 3. Press the start key. The setting is set. 4. Turn the main power switch off and on. <p>Supplement After removing the cause of the problem, be sure to change the setting in OFF.</p>	Display	Description	MODE0	Setting mode: OFF	MODE1	Setting mode: ON (Usable up to three times of use)
Display	Description						
MODE0	Setting mode: OFF						
MODE1	Setting mode: ON (Usable up to three times of use)						

Maintenance item No.	Description																
U942	<p>Setting of deflection for feeding from DP</p> <p>Description Adjusts the deflection generated when the DP is used.</p> <p>Purpose Use this mode if an original non-feed jam, oblique feed or wrinkling of original occurs when the DP is used.</p> <p>Setting</p> <ol style="list-style-type: none"> 1. Press the start key. 2. Select the item to be adjusted. <table border="1" data-bbox="333 535 1398 721"> <thead> <tr> <th>Display</th> <th>Description</th> <th>Setting range</th> <th>Initial setting</th> <th>Change in value per step</th> </tr> </thead> <tbody> <tr> <td>FEED MOT</td> <td>Deflection in the original feed motor</td> <td>-31 to 31</td> <td>0</td> <td>0.31 mm</td> </tr> <tr> <td>REV MOT</td> <td>Deflection in the original switchback motor</td> <td>-31 to 31</td> <td>0</td> <td>0.39 mm</td> </tr> </tbody> </table> <ol style="list-style-type: none"> 3. Press the system menu key. 4. Place an original on the DP and press the start key to make a test copy. 5. Press the system menu key. 6. Change the setting value using the +/- or numeric keys. The greater the value, the larger the deflection; the smaller the value, the smaller the deflection. If an original non-feed jam or oblique feed occurs, increase the setting value. If wrinkling of original occurs, decrease the value. 7. Press the start key. The setting is set. <p>Completion Press the stop key. The screen for selecting a maintenance item No. is displayed.</p>	Display	Description	Setting range	Initial setting	Change in value per step	FEED MOT	Deflection in the original feed motor	-31 to 31	0	0.31 mm	REV MOT	Deflection in the original switchback motor	-31 to 31	0	0.39 mm	
Display	Description	Setting range	Initial setting	Change in value per step													
FEED MOT	Deflection in the original feed motor	-31 to 31	0	0.31 mm													
REV MOT	Deflection in the original switchback motor	-31 to 31	0	0.39 mm													
U964	<p>Checking of log</p> <p>Description Sends a log file saved on the HDD to a USB memory.</p> <p>Purpose To transfer a log file saved on the HDD to a USB memory as a means of investigating malfunctions.</p> <p>Method</p> <ol style="list-style-type: none"> 1. Insert USB memory in USB memory slot. 2. Turn the main power switch on. 3. Enter the maintenance item. 4. Press the start key. 5. Select [Execute]. 6. Press the start key. Starts sending the log file saved on the HDD to the USB memory. 7. When normally completed, [Finished] is displayed. When an error occurs, an error code is displayed. 8. Turn the main power switch off and on. <p>Error codes</p> <table border="1" data-bbox="333 1626 1398 1957"> <thead> <tr> <th>Display</th> <th>Description</th> </tr> </thead> <tbody> <tr> <td>No Usb Storage</td> <td>USB memory is not inserted</td> </tr> <tr> <td>No File</td> <td>File is not found</td> </tr> <tr> <td>Mount Error</td> <td>USB memory mount error</td> </tr> <tr> <td>File Delete Error</td> <td>File deletion error</td> </tr> <tr> <td>Copy Error</td> <td>File copy error</td> </tr> <tr> <td>Unmount Error</td> <td>USB memory unmount error</td> </tr> <tr> <td>Other Error</td> <td>Other error</td> </tr> </tbody> </table>	Display	Description	No Usb Storage	USB memory is not inserted	No File	File is not found	Mount Error	USB memory mount error	File Delete Error	File deletion error	Copy Error	File copy error	Unmount Error	USB memory unmount error	Other Error	Other error
Display	Description																
No Usb Storage	USB memory is not inserted																
No File	File is not found																
Mount Error	USB memory mount error																
File Delete Error	File deletion error																
Copy Error	File copy error																
Unmount Error	USB memory unmount error																
Other Error	Other error																

Maintenance item No.	Description
U969	<p>Checking of toner area code</p> <p>Description Displays the toner area code.</p> <p>Purpose To check the toner area code.</p> <p>Method</p> <ol style="list-style-type: none"> 1. Press the start key. The toner area code is displayed. <p>Completion Press the stop/clear key. The screen for selecting a maintenance item No. is displayed.</p>
U977	<p>Data capture mode</p> <p>Description Store the print data sent to the machine into USB memory.</p> <p>Purpose In case to occur the error at printing, check the print data sent to the machine.</p> <p>Method</p> <ol style="list-style-type: none"> 1. Insert USB memory in USB memory slot. 2. Turn the main power switch on. 3. Enter the maintenance item. 4. Press the start key. 5. Select [Execute]. 6. Press the start key. 7. Send the print data to the machine. Once the print data is stored into USB memory, [Complete] will be displayed. <p>Completion Press the stop key. The screen for selecting a maintenance item No. is displayed.</p>
U984	<p>Checking the developing unit number</p> <p>Description Displays the developing unit number.</p> <p>Purpose To check the developing unit number.</p> <p>Method</p> <ol style="list-style-type: none"> 1. Press the start key. The number is displayed. <p>Completion Press the stop key. The screen for selecting a maintenance item No. is displayed.</p>

Maintenance item No.	Description								
U985	<p>Displaying the developing unit history</p> <p>Description Displays the past record of machine number and the developing counter.</p> <p>Purpose To check the count value machine number and the developing counter.</p> <p>Method</p> <ol style="list-style-type: none"> 1. Press the start key. Past record of 5 cases is displayed. <table border="1" data-bbox="333 506 1398 692"> <thead> <tr> <th data-bbox="339 510 636 546">Display</th> <th data-bbox="636 510 1391 546">Description</th> </tr> </thead> <tbody> <tr> <td data-bbox="339 546 636 618">MACHINE No. HISTORY1 to 5</td> <td data-bbox="636 546 1391 618">Historical records of the machine number</td> </tr> <tr> <td data-bbox="339 618 636 689">DEVELOP COUNT HISTORY1 to 5</td> <td data-bbox="636 618 1391 689">Historical records of developing counter</td> </tr> </tbody> </table> <p>Completion Press the stop key. The screen for selecting a maintenance item No. is displayed.</p>	Display	Description	MACHINE No. HISTORY1 to 5	Historical records of the machine number	DEVELOP COUNT HISTORY1 to 5	Historical records of developing counter		
Display	Description								
MACHINE No. HISTORY1 to 5	Historical records of the machine number								
DEVELOP COUNT HISTORY1 to 5	Historical records of developing counter								
U989	<p>HDD scandisk</p> <p>Description Restores data in the hard disk by scanning the disk.</p> <p>Purpose If power is turned off while accessing to the hard disk is performed, the control information in the hard disk drive may be damaged. Use this mode to restore the data.</p> <p>Method</p> <ol style="list-style-type: none"> 1. Press the start key. 2. Press [EXECUTE]. 3. Press the start key. When scanning of the disk is complete, the execution result is displayed. 4. Turn the main power switch off and on. 								
U991	<p>Checking the scanner count</p> <p>Description Displays the scanner operation count.</p> <p>Purpose To check the status of use of the scanner.</p> <p>Method</p> <ol style="list-style-type: none"> 1. Press the start key. <table border="1" data-bbox="333 1429 1398 1594"> <thead> <tr> <th data-bbox="339 1433 636 1469">Display</th> <th data-bbox="636 1433 1391 1469">Description</th> </tr> </thead> <tbody> <tr> <td data-bbox="339 1469 636 1505">COPY SCAN COUNT</td> <td data-bbox="636 1469 1391 1505">Scanner operation count for copying</td> </tr> <tr> <td data-bbox="339 1505 636 1541">FAX SCAN COUNT</td> <td data-bbox="636 1505 1391 1541">Scanner operation count for fax</td> </tr> <tr> <td data-bbox="339 1541 636 1590">OTHER SCAN COUNT</td> <td data-bbox="636 1541 1391 1590">Scanner operation count except for copying</td> </tr> </tbody> </table> <p>Completion Press the stop key. The screen for selecting a maintenance No. item is displayed.</p>	Display	Description	COPY SCAN COUNT	Scanner operation count for copying	FAX SCAN COUNT	Scanner operation count for fax	OTHER SCAN COUNT	Scanner operation count except for copying
Display	Description								
COPY SCAN COUNT	Scanner operation count for copying								
FAX SCAN COUNT	Scanner operation count for fax								
OTHER SCAN COUNT	Scanner operation count except for copying								

1-3-2 Management mode

In addition to a maintenance function for service, the machine is equipped with a management function which can be operated by users (mainly by the administrator). In this management mode, settings such as default settings can be changed.

(1) Using the management mode

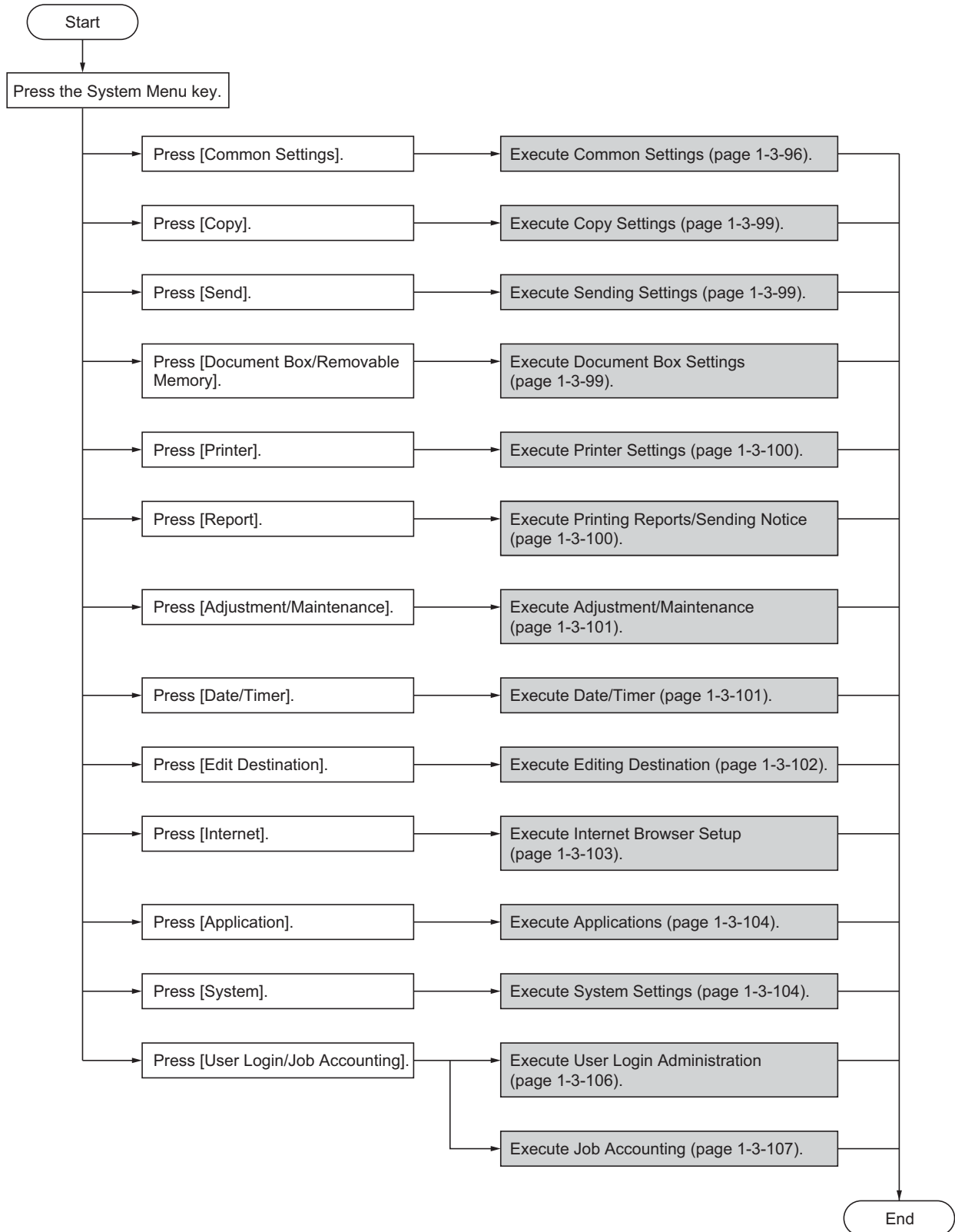

(2) Common Settings

Switching the Language for Display [Language]

1. Press [Change] of Language.
2. Press the key for the language you want to use.
3. Press [OK].
The touch panel language will be changed.

Default Screen

1. Press [Change] of Default Screen.
2. Select the screen to be displayed as the default screen.
3. Press [OK].

Sound

1. Press [Next] of Sound and then [Next] of Buzzer.
2. Press [Change] of Volume, Key Confirmation, Job Finish, Ready, or Warning.
3. Select the buzzer volume level, or other sound options.

Original/Paper Settings

1. Press [Next] of Original/Paper Settings and then [Next] of Custom Original Size.
2. Press [Change] of any one of Custom 1 to Custom 4, on which you wish to register the size.
3. Press [On], and then press [+], [-] or numeric keys to enter X (horizontal) and Y (vertical) dimensions.
4. Press [OK].

Adding a Custom Size and Media Type for Paper to Print

1. Press [Next] of Original/Paper Settings and then [Next] of Custom Paper Size.
2. Press [Change] of any one of Custom 1 to Custom 4, on which you want to register the size.
3. Press [On], and then press [+], [-] or numeric keys to enter X (horizontal) and Y (vertical) dimensions. Press [Media Type] to select the type of paper and press [OK] if necessary.
4. Press [OK].

Paper Size and Media Type Setup for Cassettes

1. Press [Next] of Original/Paper Settings, [Next] of Cassette Setting, [Next] of Cassette 1 to Cassette 4, on which you want to register the size, and then [Change] of Paper Size.
2. To detect paper size automatically, press [Auto] and select Metric or Inch for Paper Size. To select paper size, press [Standard Sizes 1] or [Standard Sizes 2] for Paper Size.
3. Press [OK]. The previous screen reappears.
4. Press [Change] of Media Type to select media type and press [OK].

Paper Size and Media Type Setup for Multi Purpose Tray

1. Press [Next] of Original/Paper Settings, [Next] of MP Tray Setting and then [Change] of Paper Size.
2. To detect paper size automatically, press [Auto] and select Metric or Inch for Paper Size. To select paper size, press [Standard Sizes 1], [Standard Sizes 2], [Others] or [Size Entry] for Paper Size. If you select [Size Entry], press [+], [-] to enter X (horizontal) and Y (vertical) dimensions. Press [# keys] to enter the paper size using the numeric keys.
3. Press [OK]. The previous screen reappears.
4. Press [Change] of Media Type to select the media type and press [OK].

Paper Weight

1. Press [Next] of Original/Paper Settings and then [Next] of Media Type Setting.
2. Press [Next] for the media type whose weight you want to change.
3. Press [Change] of Paper Weight.
4. Select the weight and press [OK].
5. Press [Close]. The previous screen reappears.
6. To change the duplex printing settings for Custom 1 (-8), press [Next] of Custom 1(-8) and then [Change] of Duplex. Select [Prohibit] or [Permit] and press [OK]. The previous screen reappears.
7. Press [Close].
8. To change the name for Custom 1(-8), press [Next] of Custom 1(-8) and then [Change] of Name. Enter the name and press [OK].

Default Paper Source

1. Press [Next] of Original/Paper Settings and then [Change] of Default Paper Source.
2. Select a paper cassette for the default setting.
3. Press [OK].

Automatic Detection of Originals (Available for metric models only)

1. Press [Next] of Original/Paper Settings and then [Change] of Original Auto Detect.
2. Select [A6] or [Hagaki] of A6/Hagaki. Select [Off] to disable automatic detection or [On] to enable automatic detection of Folio and 11x15" respectively.
3. Press [OK].

Media for Auto Selection

1. Press [Next] of Original/Paper Settings and then [Change] of Media for Auto (B & W).
2. Select [All Media Types] or any media type for paper selection.
3. Press [OK].

Paper Source for Cover Paper

1. Press [Next] of Original/Paper Settings, cursor down key and then [Change] of Paper Source for Cover.
2. Select the paper source to load cover paper.
3. Press [OK].

Special Paper Action

1. Press [Next] of Original/Paper Settings, cursor down key and then [Change] of Special Paper Action.
2. Select [Adjust Print Direction] or [Speed Priority].
3. Press [OK].

Switching Unit of Measurement

1. Press [Change] of Measurement.
2. Select [mm] for metric or [inch] for inch.
3. Press [OK].

Error Handling

1. Press [Next] of Error Handling.
2. Press [Change] at the error you wish to change the handling.
3. Select the error handling method in the selection screen for each of the errors and then press [OK].
4. The previous screen appears. To set the handling for a different error, repeat steps 2 and 3.

Paper Output

1. Press [Next] of Paper Output.
2. Press [Change] of Copy/Custom Box, Printer, FAX Port 1 or FAX Port 2.
3. Select Output Tray.
For [Finisher Tray], select [Face Up] (print surface up) or [Face Down] (print surface down) as the paper orientation at output.
4. Press [OK].

Orientation Confirmation

1. Press [Change] of Orientation Confirmation.
2. Select the default for [Off] or [On].
3. Press [OK].

Function Defaults

1. Press cursor down key, [Next] of Function Defaults and then [Change] of Original Orientation.
2. Select [Top Edge Top] or [Top Edge Left] for the default.
3. Press [OK].

Continuous Scan

1. Press cursor down key, [Next] of Function Defaults and then [Change] of Continuous Scan.
2. Select [Off] or [On] for the default. Use the procedure below to select the default quality setting for originals.
3. Press [OK].

Original Image

1. Press cursor down key, [Next] of Function Defaults and then [Change] of Original Image.
2. Select the [Text+Photo], [Photo], [Text], [for OCR] or [Printed Document] as the default.
3. Press [OK].

Scan Resolution

1. Press cursor down key, [Next] of Function Defaults and then [Change] of Scan Resolution.
2. Select the default resolution.
3. Press [OK].

Color Selection

1. Press cursor down key, [Next] of Function Defaults and then [Change] of Color Selection.
2. Select the default color mode.
3. Press [OK].

File Format

1. Press cursor down key, [Next] of Function Defaults and then [Change] of File Format.
2. Select the default file format.
3. Press [OK].

File Separation

1. Press cursor down key, [Next] of Function Defaults and then [Change] of File Separation.
2. Select the default for [Off] or [Each Page].
3. Press [OK].

Density

1. Press cursor down key, [Next] of Function Defaults, cursor down key and then [Change] of Density.
2. Select the default density.
3. Press [OK].

Zoom

1. Press cursor down key, [Next] of Function Defaults, cursor down key and then [Change] of Zoom.
2. Select the default zoom setting.
3. Press [OK].

File Name Entry

1. Press cursor down key, [Next] of Function Defaults, cursor down key and then [Change] of File Name Entry.
2. Press [File Name] to enter the file name in not more than 32 characters.
3. Press [OK].
4. Press [Date and Time] to add the date/time to the job, or press [Job No.] to add the job number to the job. The added information will be displayed in Additional Info.
5. Press [OK].

E-mail Subject/Body

1. Press cursor down key, [Next] of Function Defaults, cursor down key, and then [Change] of E-mail Subject/Body.
2. Press [Subject] to enter an E-mail subject not more than 60 characters.
3. Press [OK].
4. Press [Body] to enter an E-mail Body not more than 500 characters.
5. Press [OK].
6. Check that the entries are correct and press [OK].

Border Erase Default

1. Press cursor down key, [Next] of Function Defaults, cursor down key and then [Change] of Border Erase Default.
2. Press [+] or [-] for the Border and Gutter width to erase.
You can use the number keypad to enter the number directly.
3. Press [OK].

Border Erase to Back Page

1. Press cursor down key, [Next] of Function Defaults, cursor down key and then [Change] of Border Erase to Back Page.
2. Press [Same as Front Page] or [Do Not Erase].
3. Press [OK].

Margin Default

1. Press cursor down key, [Next] of Function Defaults, cursor down key and then [Change] of Margin Default.
2. Use the [+] or [-] to enter the margin widths for Left/Right and Top/Bottom.
You can use the number keypad to enter the number directly.
3. Press [OK].

Auto Image Rotation

1. Press cursor down key, [Next] of Function Defaults, cursor down key and then [Change] of Auto Image Rotation.
2. Select the default for [Off] or [On].
3. Press [OK].

EcoPrint

1. Press cursor down key, [Next] of Function Defaults, cursor down key twice, and then [Change] of EcoPrint.
2. Select [Off] or [On] for the default.
3. Press [OK].

PDF/TIFF/JPEG Image

1. Press cursor down key and [Next] of Function Defaults. Press cursor down key twice and then [Change] of PDF/TIFF/JPEG Image.
2. Select the default image quality from [1] (Low Quality) to [5] (High Quality).
3. Press [OK].

High Comp. PDF Image

1. Press cursor down key and [Next] of Function Defaults. Press cursor down key twice and [Change] of High Comp. PDF Image.
2. Select the default for [Compression Ratio Priority], [Standard], or [Quality Priority].
3. Press [OK].

Color TIFF Compression Settings

1. Press cursor down key and [Next] of Function Defaults. Press cursor down key twice and then [Change] of Color TIFF Compression.
2. Select [TIFF V6] or [TTN2].
3. Press [OK].

Repeat Copying

1. Press cursor down key and [Next] of Function Defaults. Press cursor down key twice and [Change] of Repeat Copy.
2. Select the default for [Off] or [On].
3. Press [OK].

Collate/Offset

1. Press cursor down key, [Next] of Function Defaults, cursor down key twice and then [Change] of Collate/Offset.
2. Select the defaults for Collate and Offset respectively.
3. Press [OK].

JPEG/TIFF Print

1. Press cursor down key, [Next] of Function Defaults, cursor down key twice and then [Change] of JPEG/TIFF Print.
2. Select the default for [Fit to Paper Size], [Image Resolution], or [Fit to Print Resolution].
3. Press [OK].

XPS Fit to Page

1. Press cursor down key, [Next] of Function Defaults, cursor down key twice and then [Change] of XPS Fit to Page.
2. Select [Off] or [On] for the default.
3. Press [OK].

(3) Copy Settings**Paper Selection**

1. Press [Change] of Paper Selection.
2. Press [Auto] or [Default Paper Source].
3. Press [OK].

Auto Paper Selection

1. Press [Change] of Auto Paper Selection.
2. Press [Most Suitable Size] or [Same as Original Size].
3. Press [OK].

Auto % Priority

1. Press [Change] of Auto % Priority.
2. Select the default for [Off] or [On].
3. Press [OK].

Reserve Next Priority

1. Press [Change] of Reserve Next Priority.
2. Select the default for [Off] or [On].
3. Press [OK].

Preset Limit

1. Press [Change] of Preset Limit.
2. Press [+] or [-] or use the numeric keys to enter the limit for the number of copies.
3. Press [OK].

Quick Setup Registration

1. Press [Next] of Quick Setup Registration.
2. Press [Change] of the function to be registered in Quick Setup.
3. Select a key (1-6) allocated on the Quick Setup Registration screen. Press [Off] to delete a key from the Quick Setup.
4. Press [OK]. If you overwrite the setting, a confirmation screen appears. Press [Yes].

(4) Sending Settings**Quick Setup Registration**

1. Press [Next] of Quick Setup Registration.
2. Press [Change] of the function to be registered in Quick Setup.
3. Select a key (1-6) allocated on the Quick Setup Registration screen. Press [Off] to delete a key from the Quick Setup.
4. Press [OK]. If you overwrite the setting, a confirmation screen appears. Press [Yes].

Color Type

1. Press [Change] of Color Type.
2. Select [RGB] or [sRGB].
3. Press [OK].

Setting the Default Send Screen

1. Press [Change] of Default Screen.
2. Press [Destination] or [Address Book].
3. Press [OK].

(5) Document Box Settings**Quick Setup Registration**

1. Press [Next] of Quick Setup Registration.
2. Press [Next] of Store File or Send.
3. Press [Change] of the function to be registered in Quick Setup.
4. Select a key (1-6) allocated on the Quick Setup screen. Press [Off] to delete a key from the Quick Setup.
5. Press [OK]. If you overwrite the setting, a confirmation screen appears. Press [Yes].

(6) Printer Settings**Emulation**

1. Press [Change] of Emulation.
2. Select the desired emulation.
3. Press [OK].

Setting of Alternative Emulation

1. Press [Change] of Emulation, [KPD(L)Auto] and then [Alt Emulation].
2. Select the desired alternative emulation and then press [OK].
3. Press [OK].

Setting of KPD(L) error report

1. Press [Change] of Emulation, [KPD(L)] or [KPD(L)Auto] and then [KPD(L) Error Report].
2. Press [On] or [Off] and then press [OK].
3. Press [OK].

EcoPrint

1. Press [Change] of EcoPrint.
2. Press [Off] or [On].
3. Press [OK].

Override A4/Letter

1. Press [Change] of Override A4/Letter.
2. Press [Off] or [On].
3. Press [OK].

Duplex

1. Press [Change] of Duplex.
2. Press [1-sided], [2-sided Bind LongEdge], or [2-sided Bind ShortEdge].
3. Press [OK].

Copies

1. Press [Change] of Copies.
2. Press [+], [-] or the numeric keys to set the default number of copies.
3. Press [OK].

Orientation

1. Press [Change] of Orientation.
2. Press [Portrait] or [Landscape].
3. Press [OK].

Form Feed Timeout

1. Press cursor down key and [Change] of Form Feed Timeout.
2. Press [+] or [-] to set the Form Feed Timeout. You can set the timeout delay in seconds. You cannot use the number keypad to enter this value.
3. Press [OK].

LF Action

1. Press cursor down key and [Change] of LF Action.
2. Press [LF Only], [LF and CR] or [Ignore LF].
3. Press [OK].

CR Action

1. Press cursor down key and [Change] of CR Action.
2. Press [CR Only], [LF and CR] or [Ignore CR].
3. Press [OK].

Paper Feed Mode

1. Press cursor down key and [Change] of Paper Feed Mode.
2. Press [Auto] or [Fixed].
3. Press [OK].

(7) Printing Reports/Sending Notice**Printing Reports**

1. Press [Next] of Print Report.
2. Press [Print] for the report you want to print. Printing starts. A confirmation screen appears. Press [Yes].

Send Result Report

1. Press [Next] of Result Report Setting, [Next] of Send Result Report and then [Change] of E-mail/Folder.
2. Press [Off], [On], or [Error Only].
3. Press [OK].

(8) Adjustment/Maintenance

Copy Density Adjustment

1. Press [Next] of Copy Density Adjustment.
2. Press [Change] of Auto or of Manual.
3. Press [-3] - [+3] (Lighter-Darker) to adjust density.
4. Press [OK].

Send/Box Density Adjust

1. Press and [Next] of Send/Box Density Adjust.
2. Press [Change] of Auto or of Manual.
3. Press [-3] - [+3] (Lighter-Darker) to adjust density.
4. Press [OK].

Print Density

1. Press [Change] of Print Density.
2. Press [1] - [5] (Lighter-Darker) to adjust density.
3. Press [OK].

Drum Refresh

1. Press [Next] of Drum Refresh 1 or Drum Refresh 2.
2. Press [Execute] to Drum Refresh.
3. After Drum Refresh is completed, press [OK] to return to the Adjustment/Maintenance screen.

Auto Drum Refresh

1. Press cursor down key and [Change] of Auto Drum Refresh.
2. Press [Off], [Standard] or [Long].
3. Press [OK].

Correcting Fine Black Lines

1. Press [Change] of Correcting Black Line.
2. Press [Off], [On(Low)] or [On(High)].
3. Press [OK].

Display Brightness

1. Press [Change] of Display Brightness.
2. Press [1] - [4] (Darker- Lighter) to adjust brightness.
3. Press [OK].

Silent Mode

1. Press [Change] of Silent Mode.
2. Press [Off] or [On].
3. Press [OK].

Auto Color Correction

1. Press cursor down key and [Change] of Auto Color Correction.
2. Press one of keys [1] to [5] (Color - B & W) to set the detection level.
3. Press [OK].

Gray Adjustment

1. Press cursor down key and then [Next] of Gray Adjustment.
2. Press [Execute]. A color pattern is printed.
3. As shown in the illustration, place the printed side down on the platen with the three black boxes aligned to the top.

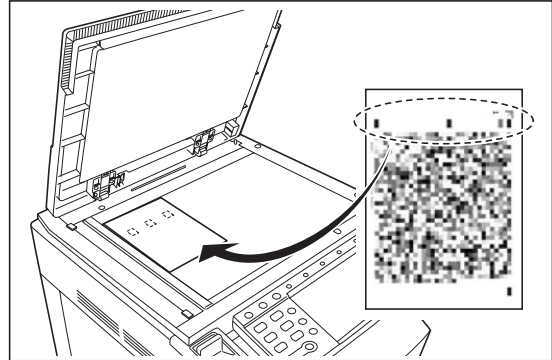

4. Press [Execute]. The color pattern is read and adjustment begins.
5. Press [OK] in the adjustment end confirmation screen.

System Initialization

1. Press [Execute] of System Initialization.
2. If user login administration is disabled, the user authentication screen appears. Enter your login user name and password and then press [Login].
3. When the confirmation screen appears, press [Yes]. Initialization starts.
4. Once the initialization ends, the message Task is completed. Turn the main power switch off and on. appears. Turn the main power switch off.

(9) Date/Timer

Date/Time

1. Press [Change] of Date/Time.
2. Press [+] or [-] to enter the date and time respectively.
3. Press [OK].

Date Format

1. Press [Change] of Date Format.
2. Select [MM/DD/YYYY], [DD/MM/YYYY], or [YYYY/MM/DD] and press [OK].

Time Zone

1. Press [Change] of Time Zone.
2. Select the location.
3. Press [Off] or [On] of Summer Time and press [OK].

Auto Panel Reset

1. Press [Change] of Auto Panel Reset.
2. Press [Off] or [On].
3. Press [OK].

Panel Reset Timer

1. Press [Change] of Panel Reset Timer.
2. Press [+] or [-] to enter the time until Auto Panel Reset is turned on.
You cannot use the number keypad to enter this value.
3. Press [OK].

Low Power Timer

1. Press [Change] of Low Power Timer.
2. Press [+], [-] or the numeric keys to enter the time until Low Power Mode is turned on.
3. Press [OK].

Auto Sleep ON/OFF

1. Press [Change] of Auto Sleep.
2. Press [Off] or [On].
3. Press [OK].

Sleep Timer

1. Press [Change] of Sleep Timer.
2. Press [+], [-] or the numeric keys to enter the time until Auto Sleep is turned on.
3. Press [OK].

Auto Error Clear ON/OFF

1. Press [Change] of Auto Error Clear.
2. Press [Off] or [On].
3. Press [OK].

Error Clear Timer

1. Press cursor down key and then [Change] of Error Clear Timer.
2. Press [+] or [-] to enter the time until printing restarts.
You cannot use the number keypad to enter this value.
3. Press [OK].

Interrupt Clear Timer

1. Press cursor down key and then [Change] of Interrupt Clear Timer.
2. Press [+] or [-] to enter the time for the interrupt clear timer.
3. Press [OK].

(10) Editing Destination (Address Book/Adding One Touch Keys)**Adding a Contact**

1. Press [Register/Edit] of Address Book, [Add], [Contact] and then [Next].
2. To specify the address number, press [Change] in Address Number.
3. Press [+], [-] or numeric keys to enter a particular Address Number (1-2500).
To have the number assigned automatically, enter "0000".
4. Press [OK]. The screen shown in step 2 reappears.
5. Press [Change] of Name.
6. Enter the destination name (up to 32 characters) to be displayed on the Address Book and press [OK]. The screen shown in step 2 reappears.
7. Press [E-mail] to add an e-mail address, [SMB] to add a folder on the computer, or [FTP] to add an FTP folder.
The procedure differs depending on the transmission method selected.

E-mail Address

1. Press [Change] of E-mail Address, enter the E-mail address and press [OK].
The table below explains the items to be entered.

The Folder (FTP) Address

1. Press [Change] of Host Name, Path, Login User Name and Login Password, enter the information for each item and press [OK].

The Folder (SMB) Address

1. Press [Change] of Host Name, Path, Login User Name and Login Password, enter the information for each item and press [OK].
8. Check if the destination entry is correct and press [Register]. The destination is added to the Address Book.

Adding a Group

1. Press [Register/Edit] of Address Book, [Add], [Group] and then [Next].
2. To specify the address number, press [Change] in Address Number.
3. Use [+], [-] or the numeric keys to enter an address number (1 to 2500).
To have the number assigned automatically, set "0000".
4. Press [OK]. The Add Group screen reappears.
5. Press [Change] of Name.
6. Enter the group name displayed on the Address Book not more than 32 characters.
7. Press [Member].
8. Press [Add].
9. Select a destination (contacts) to add to the group.
10. Press [OK].
If you have more destinations to add, repeat Steps 8 to 10.
11. Check if the selected destination was added to the group and press [Register]. Now the group is added to the Address Book.

Editing a Destination

1. Press [Register/Edit] of Address Book.
2. Select a destination or group to edit.
3. Press [Detail].

The procedure differs depending on the details to be edited.

Editing an Individual Destination

1. Change Address Number, Name and destination type and address.
2. After you have completed the changes, press [Register].
3. Press [Yes] in the change confirmation screen to register the changed destination.

Editing a Group

1. Change Address Number and Name.
2. Press [Member].
3. To delete any destination from the group, select the destination and press [Delete]. Press [Yes] on the screen to confirm the deletion.
4. After you have completed the changes, press [Register].
5. Press [Yes] in the change confirmation screen to register the changed group.

Deleting an Individual Destination or Group

1. Press [Delete]. Press [Yes] on the screen to confirm the deletion. Deletion is performed.

Adding a Destination on One Touch Key

1. Press [Register/Edit] of One touch Key.
2. Select a One Touch Key number (0001 to 1000) for the destination. Pressing Quick No. Search key or [No.] enables direct entry of a One Touch Key number. Select a One Touch Key with no registered destination.
3. Press [Register/Edit]. The address book appears.
4. Select a destination (individual or group) to add to the One Touch Key number. Pressing [Detail] shows the detailed information of the selected destination.
5. Press [OK]. The destination will be added to the One Touch Key.

Editing One Touch Key

1. Press [Register/Edit] of One Touch Key.
2. Select a One Touch Key number (0001 to 1000) for the destination. Pressing Quick No. Search key or [No.] enables direct entry of a One Touch Key number.

The procedure differs depending on the details to be edited.

Changing the Registered Information

1. Press [Register/Edit].
2. Select a new destination (individual or group). Pressing [Detail] shows the detailed information of the selected destination.
3. Press [OK].
4. Press [Yes] on the screen to add the destination to the One Touch Key.

Deleting the Registered Information

1. Press [Delete].
2. Press [Yes] on the screen to confirm the deletion of the data registered in the One Touch Key.

Sort Settings

1. Press [Next] of Address Book Defaults and then [Change] of Sort.
2. Select [No.] or [Name].
3. Press [OK].

Narrow Down Settings

1. Press [Next] of Address Book Defaults and then [Change] of Narrow Down.
2. Select the type of destination filter.
3. Press [OK].

(11) Internet Browser Setup

Internet Browser Setting

1. Press [Change] of Internet Browser.
2. Press [On] or [Off].
3. Press [OK].

Browser Preferences

1. Press [Next] of Browser Environment.
2. To set your home page, press [Change] of Home Page, press [URL], enter the URL and then press [OK]. Press [OK] again.
3. To set the text size, press [Change] of Text Size, select [Large], [Medium] or [Small] as the text size and then press [OK].
4. To set the display mode, press [Change] of Display Mode, select [Normal], [Just-Fit Rendering] or [Smart-Fit Rendering] as the display mode and then press [OK].
5. To specify the settings for accepting cookies, press [Change] of Cookie, select [Accept All], [Reject All] or [Prompt before Accepting] as your cookie acceptance policy and then press [OK].

Proxy Settings

1. Press [Change] of Proxy and then press [On].
 - To set a proxy server (HTTP)**
 1. Press [Keyboard] of Proxy Server (HTTP), enter the proxy address and press [OK].
 2. Press [# Keys] and enter the port number.
 - To set a proxy server (HTTPS)**
 1. Press [Keyboard] of Proxy Server (HTTPS), enter the proxy address and press [OK].
 2. Press [# Keys] and enter the port number.
 - To set domains for which no proxy is used**
 1. Press [Keyboard] of Do Not Use Proxy for Following Domains, enter the domain name and press [OK].
 2. Press [OK].

(12) Applications

Installing Applications

1. Insert the USB memory containing the application to be installed into the USB memory slot (A1).
2. Press [Add].
3. Select the application to be installed and press [Install].
You can view detailed information on the selected application by pressing [Detail].
4. When the confirmation screen appears, press [Yes].
Installation of the application begins. Depending on the application being installed, the installation may take some time. Once the installation ends, the original screen reappears.
5. To install another application, repeat steps 3 to 4.
6. To remove the USB memory, press [Remove Memory] and wait until the Removable Memory can be safely removed message appears. Then remove the USB memory.

Activating/Deactivating Application

1. Select the desired application and press [Activate].
You can view detailed information on the selected application by pressing [Detail].
2. Enter the license key and press [Official]. Some applications do not require you to enter a license key. If the license key entry screen does not appear, go to Step 3.
To use the application as a trial, press [Trial] without entering the license key.
3. When the confirmation screen appears, press [Yes].

Deleting Applications

1. Select the application to be deleted and press [Delete].
You can view detailed information on the selected application by pressing [Detail].
2. When the deletion confirmation screen appears, press [Yes]. The application is deleted.

(13) System Settings

Restarting the System

1. Press [Execute] of Restart.
2. When the confirmation screen appears, press [Yes]. The system is restarted.

Network Setup

TCP/IP (IPv4) Setup

1. Press [Next] of Network and then [Next] of TCP/IP Setting.
2. Press [Change] of TCP/IP.
3. Press [On] and then press [OK].
4. Press [Change] of IPv4.
5. Press [DHCP].
6. Press [Off] of DHCP and then press [OK].
7. Press [Bonjour].
8. Press [Off] of Bonjour and then press [OK].
9. Press [IP Address] and enter the address using the numeric keys.
10. Press [Subnet Mask] and enter the address using the numeric keys.
11. Press [Default Gateway] and enter the address using the numeric keys.
12. Check if all the address entries are correct and press [OK].
13. After changing the setting, restart the system or turn the machine OFF and then ON again.

TCP/IP (IPv6) Setup

1. Press [Next] of Network and then [Next] of TCP/IP Setting.
2. Press [Change] of TCP/IP.
3. Press [On] and then press [OK].
4. Press [Next] of IPv6.
5. Press [Change] of IPv6.
6. Press [On].
7. Press [OK].
8. After changing the setting, restart the system or turn the machine OFF and then ON again.

Manual Setting (IPv6)

1. Press [Next] of Network and then [Next] of TCP/IP Setting.
2. Press [Next] of IPv6.
3. Press [Next] of Manual Setting.
4. Press [IP Address (Manual)] to enter IP address.
5. Press [OK].
Press [# Keys] of Prefix Length (0 - 128) to enter the prefix length using the numeric keys.
6. Press [Default Gateway] to enter the default gateway.
7. Check that all the entries are correct and Press [OK].
8. After changing the setting, restart the system or turn the machine OFF and then ON again.

RA (Stateless) Settings

1. Press [Next] of Network and then [Next] of TCP/IP Setting.
2. Press [Next] of IPv6.
3. Press [Change] of RA(Stateless).
4. Press [On] or [Off] of RA (Stateless).
5. Press [OK].
6. After changing the setting, restart the system or turn the machine OFF and then ON again.

DHCP (IPv6) Settings

1. Press [Next] of Network and then [Next] of TCP/IP Setting.
2. Press [Next] of IPv6.
3. Press [Change] of DHCP.
4. Press [On] or [Off] of DHCP.
5. Press [OK].
6. After changing the setting, restart the system or turn the machine OFF and then ON again.

NetWare Setup

1. Press [Next] of Network and then [Change] of NetWare.
2. Press [On].
3. Press the key for the frame type you want to use.
4. Press [OK].
5. After changing the setting, restart the system or turn the machine OFF and then ON again.

AppleTalk Setup

1. Press [Next] of Network and then [Change] of AppleTalk.
2. Press [On] or [Off].
3. Press [OK].
4. After changing the setting, restart the system or turn the machine OFF and then ON again.

WSD Scan Setup

1. Press [Next] of Network and then [Change] of WSD Scan.
2. Press [On] or [Off].
3. Press [OK].
4. After changing the setting, restart the system or turn the machine OFF and then ON again.

WSD Print Setup

1. Press [Next] of Network and then [Change] of WSD Print.
2. Press [On] or [Off].
3. Press [OK].
4. After changing the setting, restart the system or turn the machine OFF and then ON again.

SSL Setup

1. Press [Next] of Network, [Next] of Secure Protocol, and then [Next] of SSL.
2. Press [On] or [Off].
3. Press [OK].
4. After changing the setting, restart the system or turn the machine OFF and then ON again.

IPP Security Setup

1. Press [Next] of Network, [Next] of Secure Protocol, and then [Change] of IPP Security.
2. Press [IPP over SSL Only] or [IPP or IPP over SSL].
3. Press [OK].
4. After changing the setting, restart the system or turn the machine OFF and then ON again.

HTTP Security Setup

1. Press [Next] of Network, [Next] of Secure Protocol, and then [Change] of HTTPS Security.
2. Press [HTTP or HTTPS] or [HTTPS Only].
3. Press [OK].
4. After changing the setting, restart the system or turn the machine OFF and then ON again.

LDAP Security Setup

1. Press [Next] of Network, [Next] of Secure Protocol, and then [Change] of LDAP Security.
2. Press [Off], [LDAP over SSL] or [LDAPv3/TLS].
3. Press [OK].
4. After changing the setting, restart the system or turn the machine OFF and then ON again.

IPSec Setting

1. Press [Next] of Network, and then [Change] of IPSec.
2. Press [On].
3. Press [OK].
4. After changing the setting, restart the system or turn the machine OFF and then ON again.

LAN Interface Setup

1. Press [Next] of Network and then [Change] of LAN Interface.
2. Select [Auto], [10BASE-T Half], [10BASE-T Full], [100BASE-TX Half] or [100BASE-TX Full] as the LAN interface.
3. Press [OK].
4. After changing the setting, restart the system or turn the machine OFF and then ON again.

Interface Block Setting

USB Host (USB memory slot setting)

1. Press [Next] of Interface Block Setting and then [Change] of USB Host.
2. If user login administration is disabled, the user authentication screen appears. Enter your login user name and password and then press [Login].
3. Press [Block].
4. Press [OK].

USB Device (USB interface setting)

1. Press [Next] of Interface Block Setting and then [Change] of USB Device.
2. Press [Block].
3. Press [OK].

Optional interface (Optional interface card setting)

1. Press [Next] of Interface Block Setting and then [Change] of Optional Interface 1 or Optional Interface 2.
2. Press [Block].
3. Press [OK].

Document Guard Setting

1. Press and then [Change] of Document Guard.
2. If user login administration is disabled, the user authentication screen appears. Enter your login user name and password and then press [Login].
3. Press [Activate].
4. Press [OK].

Optional Functions

Starting Application Use

1. Press [Next] of Optional Function.
2. If user login administration is disabled, the user authentication screen appears. Enter your login user name and password and then press [Login].
3. Select the desired application and press [Activate]. You can view detailed information on the selected application by pressing [Detail].
4. In the license key entry screen, press [Official]. Some applications do not require you to enter a license key. If the license key entry screen does not appear, go to Step 4. To use the application as a trial, press [Trial] without entering the license key.
5. When the confirmation screen appears, press [Yes].

Checking Application Details

1. Press [Next] of Optional Function.
2. If user login administration is disabled, the user authentication screen appears. Enter your login user name and password and then press [Login].
3. Select the application you want to check the details of and press [Detail]. You can now view detailed information on the selected application.

(14) User Login Administration

Enabling/Disabling User Login Administration

1. If user login administration is disabled, the user authentication screen appears. Enter your login user name and password and then press [Login].
2. Press [Next] of User Login Setting and then [Change] of User Login.
3. Select [Local Authentication] or [Network Authentication]. Select [Off] to disable user login administration. If you select [Network Authentication], enter the host name (62 characters or less) and domain name (256 characters or less) for the Authentication Server. Select [NTLM] or [Kerberos] as the server type.
4. Press [OK].

Adding a User

1. If user login administration is disabled, the user authentication screen appears. Enter your login user name and password and then press [Login].
2. Press [Next] of User Login Setting, [Register/Edit] of Local User List, and then [Add].
3. Press [Change] of User Name.
4. Enter the user name and press [OK].
5. Enter the login user name and E-mail address following 3 and 4 above.
6. Press [Change] of Login Password and then [Password].
7. Enter the login password and press [OK].
8. Press [Confirm Password].
9. Enter the same login password to confirm and press [OK].
10. Press [OK].
11. Press [Change] of Access Level.
12. Select the user access privilege and press [OK].
13. Press [Change] of Account Name.
14. Select the account and press [OK].
15. Press [Register] to add a new user on the local user list.

Changing User Properties

1. If user login administration is disabled, the user authentication screen appears. Enter your login user name and password and then press [Login].
2. Press [Next] of User Login Setting and [Register/Edit] of Local User List.
3. Select the user whose properties you wish to change.

The procedure differs depending on the details to be edited.

Changing user information

1. Press [Detail].
2. Refer to steps 3 to 14 of Adding a User to change a user property.
3. Press [Register].
4. Press [Yes] in the registration confirmation screen. The user information is changed.

Deleting a user

1. Press [Delete].
2. Press [Yes] on the screen to confirm deletion. The selected user will be deleted.

Unknown login user name Job

1. If user login administration is disabled, the user authentication screen appears. Enter your login user name and password and then press [Login].
2. Press [Change] of Unknown ID Job.
3. Press [Reject] or [Permit].
4. Press [OK].

Group Authorization

1. If user login administration is disabled, the user authentication screen appears. Enter your login user name and password and then press [Login].
2. Press [Next] of User Login Setting, [Next] of Group Authorization Set., and then [Change] of Group Authorization.
3. Press [On].
4. Press [OK].

Group List

1. If user login administration is disabled, the user authentication screen appears. Enter your login user name and password and then press [Login].
2. Press [Next] of User Login Setting, [Next] of Group Authorization Set., [Register/Edit] of Group List, and then [Add].
3. Press [Change] of Group ID.
4. Enter the group ID and press [OK].
5. Press [Change] of Group Name.
6. Enter the group name and press [OK].
7. Press [Change] of Access Level.
8. Select the user access privilege and press [OK].
9. Press [Change] of Print Restriction.
10. Select [Reject Usage] or [Off] and press [OK].
11. Follow steps 9 and 10 above to set Copy Restriction, Send Restriction, FAX TX Restriction, Storing Restr. in Box, and Storing Restr. in Memory.
12. Press [Register] to add a new group on the group list.

Obtain Network User Property

1. If user login administration is disabled, the user authentication screen appears. Enter your login user name and password and then press [Login].
2. Press [Next] of User Login Setting, [Change] of Obtain NW User Property.
3. Press [On].
4. Press [Server Name].
5. Enter the LDAP server name or the IP address and press [OK].
6. Press [# keys] to enter the LDAP port number using the numeric keys.
7. Press [Name 1].
8. Enter the LDAP Attribute to obtain the user name to be displayed and press [OK].
9. Follow steps 7 and 8 above to set Name 2.
10. Press [E-mail Address].
11. Enter the LDAP Attribute to obtain the e-mail address and press [OK].
12. Press [Search Timeout] to set the amount of time to wait before time-out.
13. Press [+], [-] or the numeric keys to enter the time.
14. Press [LDAP Security] to select the type of encryption according to the type of security employed by the LDAP server.
15. Select [Off], [LDAP over SSL], or [LDAPv3/TLS] and press [OK].

(15) Job accounting

Enabling/Disabling Job Accounting

1. If user login administration is disabled, the user authentication screen appears. Enter your login user name and password and then press [Login].
2. Press [Next] of Job Accounting Setting, and then [Change] of Job Accounting.
3. Press [On]. To disable job accounting, press [Off].
4. Press [OK].

Adding an Account

1. If user login administration is disabled, the user authentication screen appears. Enter your login user name and password and then press [Login].
2. Press [Next] of Job Accounting Setting, [Register/Edit] of Accounting List, and then [Add].
3. Press [Change] of Account Name.
4. Enter the account name and press [OK]. The Account screen reappears.
5. Follow steps 3 and 4 above to enter the Account ID.
6. Activate or deactivate restriction.
7. Press [Register] to add a new account on the Account List.

Managing Accounts

1. If user login administration is disabled, the user authentication screen appears. Enter your login user name and password and then press [Login].
2. Press [Next] of Job Accounting Setting and then [Register/Edit] of Accounting List.
3. Select an account to change or delete.

Changing account information

1. Press [Detail].
2. Refer to steps 3 to 5 of Adding an Account and steps 3 to 6 of Restricting Using the Machine to change account information.
3. Press [Register].
4. Press [Yes] in the registration confirmation screen. The account information is changed.

Deleting an account

1. Press [Delete].
2. Press [Yes]. To delete the account.

Managing the Copier/Printer Counts

1. If user login administration is disabled, the user authentication screen appears. Enter your login user name and password and then press [Login].
2. Press [Next] of Job Accounting Setting, [Next] of Default Setting and then [Change] of Copier/Printer Count.
3. Press [Total] or [Split].
4. Press [OK].

Applying Restriction

1. If user login administration is disabled, the user authentication screen appears. Enter your login user name and password and then press [Login].
2. Press [Next] of Job Accounting Setting, [Register/Edit] of Accounting List, and then [Add].
3. Press [Change] for the item to be restricted.
4. Select the restriction mode.
If [Counter Limit] is selected, press [+],[-] or numeric keys to select the number of pages.
5. Press [OK].
6. Repeat steps 3 to 5 for other accounts to be restricted.
7. Press [Register]. The restricted account is added.

Applying Limit of Restriction

1. If user login administration is disabled, the user authentication screen appears. Enter your login user name and password and then press [Login].
2. Press [Next] of Job Accounting Setting, [Next] of Default Setting and then [Change] of Apply Limit.
3. Select [Immediately], [Subsequently], or [Alert Only].
4. Press [OK].

Default Counter Limit

1. If user login administration is disabled, the user authentication screen appears. Enter your login user name and password and then press [Login].

2. Press [Next] of Job Accounting Setting, [Next] of Default Setting and then [Next] of Default Counter Limit.
3. Press [Change] for the item you want to modify and then press [+] or [-] or use the numeric keys to enter the default restriction on the number of sheets.
4. Press [OK].
5. To set another default restriction, repeat steps 3 to 4.

Total Job Accounting/Resetting the Counter

1. If user login administration is disabled, the user authentication screen appears. Enter your login user name and password and then press [Login].
2. Press [Next] of Job Accounting Setting and then [Next] of Total Job Accounting.
3. Press [Check] at the function to check the count. The results will be displayed.
4. Confirm the count and press [Close].
5. Press [Execute] of Counter Reset to reset the counter.
6. Press [Yes] on the screen to confirm the reset. The counter is reset.

Each Job Accounting/Resetting the Counter

1. If user login administration is disabled, the user authentication screen appears. Enter your login user name and password and then press [Login].
2. Press [Next] of Job Accounting Setting and [Check] of Each Job Accounting.
3. Select the account to check the count.
4. Press [Detail].
5. Press [Check] at the function to check the count. The results will be displayed.
6. Confirm the count and press [Close].
7. Press [Execute] of Counter Reset to reset the counter.
8. Press [Yes] on the screen to confirm the reset. The counter will be reset.

Counting by Paper Size

1. If user login administration is disabled, the user authentication screen appears. Enter your login user name and password and then press [Login].
2. Press [Next] of Job Accounting Setting, [Next] of Default Setting, [Change] of Count by Paper Size, [Change] of Paper Size 1 to 5 and then [On].
3. Select the paper size.
4. Press [Media Type] to specify media type.
5. Select the media type and press [OK].
6. Press [Close].

Printing an Accounting Report

1. If user login administration is disabled, the user authentication screen appears. Enter your login user name and password and then press [Login].
2. Press [Next] of Job Accounting Setting and then [Print] of Print Accounting Report.
3. Press [Yes] on the screen to confirm the printing.

1-4-1 Paper misfeed detection

(1) Paper misfeed indication

When a paper misfeed occurs, the machine immediately stops copying and displays the jam location on the operation panel.

Paper misfeed counts sorted by the detection condition can be checked in maintenance item U903.

To remove paper jammed in the machine, open the front cover, left cover or pull the cassette out.

To remove original jammed in the optional DP, open the document processor top cover.

To remove the jammed paper in optional document finisher, detach the finisher from the machine.

Paper misfeed detection can be reset by opening and closing the respective covers to turn safety switch off and on.

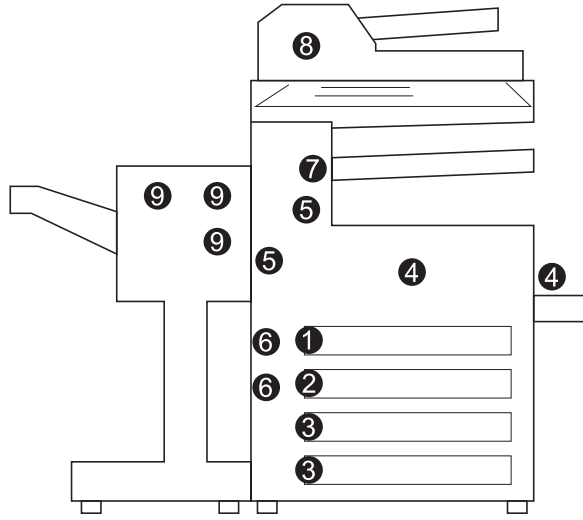

Figure 1-4-1

- (1) Misfeed in cassette 1
- (2) Misfeed in cassette 2
- (3) Misfeed in optional cassette 3 or 4
- (4) Misfeed in MP tray
- (5) Misfeed in duplex unit or left cover 1
- (6) Misfeed in left cover 2 or 3
- (7) Misfeed in optional built-in finisher
- (8) Misfeed in optional DP
- (9) Misfeed in optional document finisher

(2) Paper misfeed detection conditions

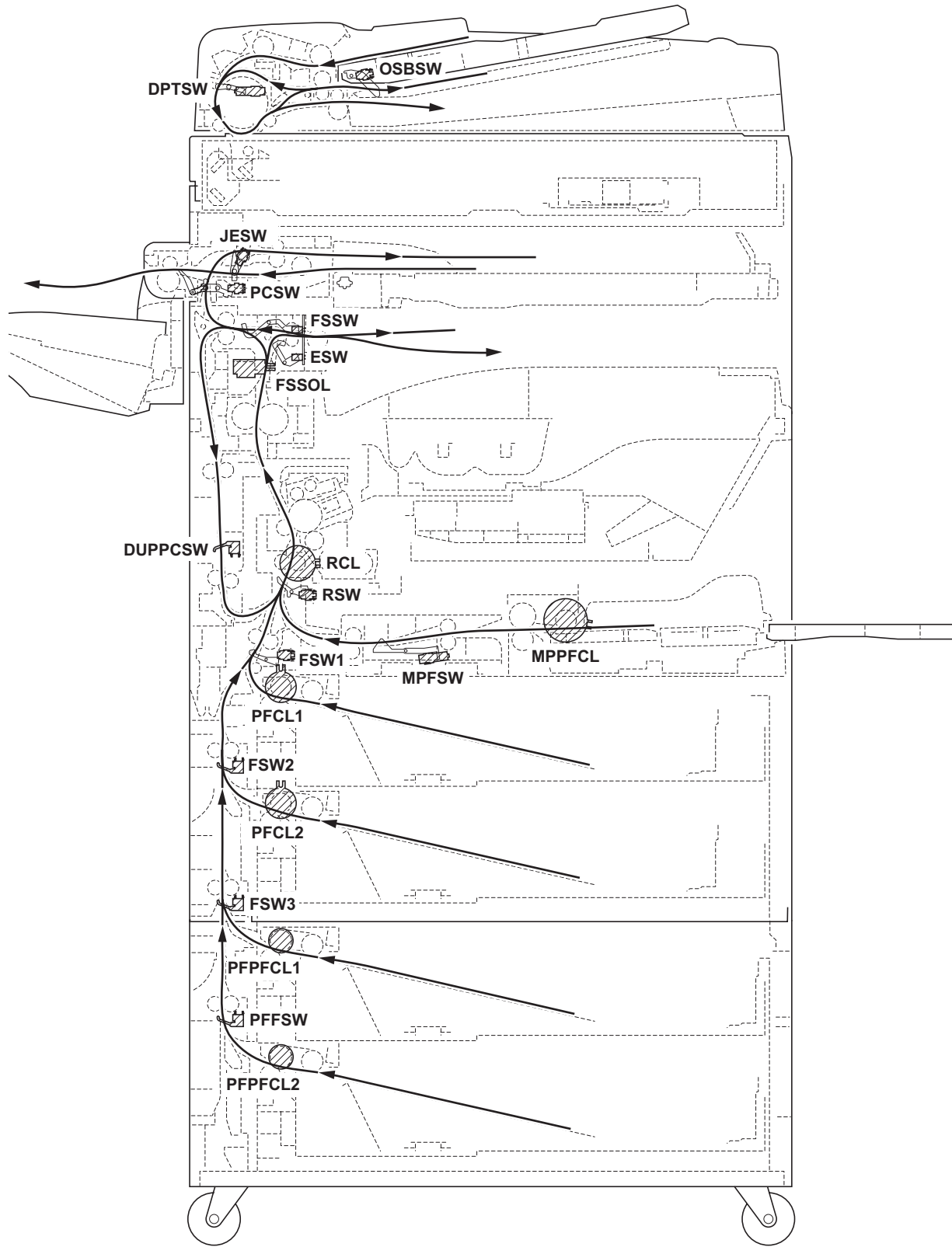

Figure 1-4-2

Section	Description	Conditions	Specified time
System	04 Cover open	Cover is open during copying.	-
	05 Secondary paper feed does not start	Secondary paper feed does not start within specified time of arrival of paper at the registration section.	30 s
Paper feed section	10 No paper feed from cassette 1	Feed switch 1 (FSW1) does not turn on within the specified time of paper feed clutch 1 (PFCL1) turning on; the clutch is then successively turned off for 1 s and turned back on, but the switch again fails to turn on within the specified time.	1864 ms
	11 No paper feed from cassette 2	Feed switch 2 (FSW2) does not turn on within the specified time of paper feed clutch 2 (PFCL2) turning on; the clutch is then successively turned off for 1 s and turned back on, but the switch again fails to turn on within the specified time.	2121 ms
	12 No paper feed from optional cassette 3	Feed switch 3 (FSW3) does not turn on within the specified time of PF paper feed clutch 1 (PFPFCL1) turning on; the clutch is then successively turned off for 1 s and turned back on, but the switch again fails to turn on within the specified time.	-
		Left cover 3 is opened in prior to feed switch 3 (FSW3) is turned on.	-
	13 No paper feed from optional cassette 4	The PF feed switch (PFFSW) does not turn on within the specified time of PF paper feed clutch 2 (PFPFCL2) turning on; the clutch is then successively turned off for 1 s and turned back on, but the switch again fails to turn on within the specified time.	-
		Left cover 3 is opened in prior to the PF feed switch (PFFSW) is turned on.	-
	14 No paper feed from MP tray	The MP feed switch (MPFSW) does not turn on within the specified time of the MP paper feed clutch (MPPFCL) turning on; the clutch is then successively turned off for 1 s and turned back on, but the switch again fails to turn on within the specified time.	993 ms
	18 Misfeed in vertical paper conveying section	Feed switch 1 (FSW1) does not turn off within specified time of feed switch 2 (FSW2) turning on (paper feed from cassette 2).	1314 ms
		Feed switch 1 (FSW1) does not turn on within specified time of feed switch 2 (FSW2) turning on (paper feed from cassette 2).	1314 ms
		Feed switch 1 (FSW1) does not turn off within specified time of feed switch 2 (FSW2) turning on (paper feed from optional cassette 3, 4).	1386 ms
		Feed switch 1 (FSW1) does not turn on within specified time of feed switch 2 (FSW2) turning on (paper feed from optional cassette 3, 4).	1386 ms
		Feed switch 2 (FSW2) does not turn off within specified time of feed switch 3 (FSW3) turning on (paper feed from optional cassette 3, 4).	1686 ms
Feed switch 2 (FSW2) does not turn on within specified time of feed switch 3 (FSW3) turning on (paper feed from optional cassette 3, 4).		1686 ms	

Section	Description	Conditions	Specified time
Paper feed section	19 Misfeed in paper feeder vertical paper conveying section	The feed switch 3 (FSW3) does not turn off within specified time of its turning on (paper feed from optional cassette 3).	1429 ms + Paper length
		Feed switch 3 (FSW3) does not turn off within specified time of the PF feed switch (PFFSW) turning on (paper feed from optional cassette 4).	1064 ms
		The feed switch 3 (FSW3) does not turn off within specified time of its turning on (paper feed from optional cassette 4).	1064 ms
		Feed switch 3 (FSW3) does not turn on within specified time of the PF feed switch (PFFSW) turning on (paper feed from optional cassette 4).	2000 ms
	20 Misfeed in MP tray paper conveying section	The registration switch (RSW) does not turn off within specified time of the MP feed switch (MPFSW) turning on.	1686 ms
		The registration switch (RSW) does not turn on within specified time of the MP feed switch (MPFSW) turning on.	1686 ms
	21 Multiple sheets in paper feed section	The feed switch 1 (FSW1) does not turn off within specified time of its turning on (paper feed from cassette 1).	1429 ms + Paper length
		The feed switch 2 (FSW2) does not turn off within specified time of its turning on (paper feed from cassette 2).	1429 ms + Paper length
		The feed switch 3 (FSW3) does not turn off within specified time of its turning on (paper feed from optional cassette 3, 4/detected by the machine).	1429 ms + Paper length
		The feed switch 3 (FSW3) does not turn off within specified time of its turning on (paper feed from optional cassette 3, 4/detected by the paper feeder).	4300 ms
The feed switch 2 (FSW2) does not turn off within specified time of its turning on (paper feed from optional cassette 3).		1686 ms	
The PF feed switch (PFFSW) does not turn off within specified time of its turning on (paper feed from optional cassette 4).		4300 ms	
The feed switch 1 (FSW1) does not turn off within specified time of the paper feed clutch 1 (PFCL1) turning on.		1864 ms	
The feed switch 2 (FSW2) does not turn off within specified time of the paper feed clutch 2 (PFCL2) turning on.		2121 ms	
The feed switch 3 (FSW3) does not turn off within specified time of the PF paper feed clutch 1 (PFPFCL1) turning on.		2036 ms	
23 Multiple sheets in MP tray conveying section	The MP feed switch (MPFSW) does not turn off within specified time of its turning on.	1429 ms + Paper length	

Section	Description	Conditions	Specified time	
Paper conveying section	30 Misfeed in registration/ transfer section	The registration switch (RSW) does not turn off within specified time of the feed switch 1 (FSW1) turning off.	1314 ms	
		The registration switch (RSW) does not turn off within specified time of the feed switch 1 (FSW1) turning on.	1100 ms	
		The registration switch (RSW) does not turn on within specified time of the feed switch 1 (FSW1) turning on.	1100 ms	
		The registration switch (RSW) does not turn off within specified time of the MP feed switch (MPFSW) turning off.	1686 ms	
Fuser section	40 Misfeed in fuser section (MP tray)	The eject switch (ESW) does not turn on within specified time of the registration clutch (RCL) turning on.	2321 ms	
		The feedshift switch (FSSW) does not turn on within specified time of the registration clutch (RCL) turning on.	1336 ms	
	41 Misfeed in fuser section (cassette 1)	The eject switch (ESW) does not turn on within specified time of the registration clutch (RCL) turning on.	2321 ms	
		The feedshift switch (FSSW) does not turn on within specified time of the registration clutch (RCL) turning on.	1336 ms	
	42 Misfeed in fuser section (cassette 2)	The eject switch (ESW) does not turn on within specified time of the registration clutch (RCL) turning on.	2321 ms	
		The feedshift switch (FSSW) does not turn on within specified time of the registration clutch (RCL) turning on.	1336 ms	
	43 Misfeed in fuser section (optional cassette 3)	The eject switch (ESW) does not turn on within specified time of the registration clutch (RCL) turning on.	2321 ms	
		The feedshift switch (FSSW) does not turn on within specified time of the registration clutch (RCL) turning on.	1336 ms	
	44 Misfeed in fuser section (optional cassette 4)	The eject switch (ESW) does not turn on within specified time of the registration clutch (RCL) turning on.	2321 ms	
		The feedshift switch (FSSW) does not turn on within specified time of the registration clutch (RCL) turning on.	1336 ms	
	47 Misfeed in fuser section (duplex section)	The eject switch (ESW) does not turn on within specified time of the registration clutch (RCL) turning on.	2321 ms	
		The feedshift switch (FSSW) does not turn on within specified time of the registration clutch (RCL) turning on.	1336 ms	
	Eject section	50 Misfeed in eject section	The eject switch (ESW) does not turn off within specified time of the registration switch (RSW) turning off.	2321 ms
			The eject switch (ESW) does not turn off within specified time of the registration clutch (RCL) turning on.	2321 ms
51 Misfeed in job separator eject section		The job separator eject switch (JESW) does not turn on within specified time of the feedshift switch (FSSW) turning on.	1350 ms	
		The job separator eject switch (JESW) does not turn off within specified time of the feedshift switch (FSSW) turning off.	714 ms + Paper length	
		The job separator eject switch (JESW) does not turn off within specified time of the feedshift switch (FSSW) turning on.	1350 ms	

Section	Description	Conditions	Specified time
Feedshift section	52 Misfeed in feedshift section	The feedshift switch (FSSW) does not turn on within specified time of the start of eject motor (EM) reverse rotation.	1121 ms
		During paper switchback operation, the feedshift switch (FSSW) does not turn off within specified time of the its turning on.	4514 ms
		The feedshift switch (FSSW) does not turn off within specified time of the its turning on.	4514 ms
		The feedshift switch (FSSW) does not turn off within specified time of the registration clutch (RCL) turning on.	2321 ms
Duplex section	60 Duplex paper conveying section 1	The duplex paper conveying switch (DUPPCSW) does not turn on within specified time of the feedshift switch (FSSW) turning on.	2621 ms
		The duplex paper conveying switch (DUPPCSW) does not turn off within specified time of the feedshift switch (FSSW) turning off.	2629 ms
	61 Duplex paper conveying section 2	The registration switch (RSW) does not turn on within specified time of the duplex paper conveying switch (DUPPCSW) turning on.	1636 ms
		The registration switch (RSW) does not turn off within specified time of the duplex paper conveying switch (DUPPCSW) turning off.	1493 ms
Optional DP	70 No original feed	The DP timing switch (DPTSW) does not turn on within specified time during the first sheet feeding (Retry 5 times).	1468 pulses
		The DP timing switch (DPTSW) does not turn on within specified time during the second sheet feeding (Retry 5 times).	1468 pulses
	71 An original jam in the original conveying section 1	DP timing switch (DPTSW) does not turn off within specified time of the original conveying motor (OCM) turning on.	9900 pulses
	72 An original jam in the original conveying section 2	DP timing switch (DPTSW) turns off within the specified time of period of the original conveying motor (OCM) turning on.	1145 pulses
	73 An original jam in the original switchback section	DP timing switch (DPTSW) does not turn off within specified time of the original switchback motor (OSBM) turning on.	9900 pulses
	74 An original jam in the original switchback/feed section	DP timing switch (DPTSW) does not turn on within specified time of the original switchback motor (OSBM) turning on.	10700 pulses
	75 An original jam in the original switchback/conveying section	The original switchback switch (OSBSW) does not turn on within specified time of the DP timing switch (DPTSW) turning off.	1724 pulses
	78 Document processor cover open	The document processor or document processor top cover is opened during original feeding. DP timing switch (DPTSW) or original switchback switch (OSBSW) turns on when starting the original paper feed.	-

Section	Description	Conditions	Specified time
Optional finisher	80 Finisher timeout jam (built-in finisher)	(Document finisher) Paper ejection is not output from the machine to the document finisher within specified time of the paper entry sensor (PES) turning on.	15 s
		(Built-in finisher) Paper ejection is not output from the machine to the document finisher within specified time of the paper conveying switch (PCSW) turning on.	15 s
81	Paper entry sensor nonarrival jam	(Document finisher) The paper entry sensor (PES) is not turned on even if a specified time has elapsed after the machine eject signal was received.	1201 ms
		(Built-in finisher) The paper conveying switch (PCSW) is not turned on even if a specified time has elapsed after the machine eject signal was received.	2000 ms
		(Built-in finisher) The paper conveying switch (PCSW) does not turn off within specified time of its turning on when paper is conveyed to the process table from the paper conveying unit.	1429 ms + Paper length
82	Jam in stapler	(Document finisher) The staple home position sensor (STSPS) is not turned on within the specified time when driving the staple motor (STM).	-
		(Built-in finisher) The staple home position sensor (STHPS) is not turned on within the specified time when driving the staple motor (STM).	600 ms
83	Exit sensor stay jam	(Document finisher) In the straight mode, the exit sensor (EPS) is not turned off within specified time of its turning on.	-
		(Document finisher) In the bundle discharge mode or the staple mode, bundle discharge operation does not turn off within specified time since the operation starts.	902 ms
		(Built-in finisher) The paper conveying switch (PCSW) does not turn off within specified time of its turning on when paper is ejected to the finisher tray from the process table.	1429 ms + Paper length
91	Finisher cover open (document finisher)	The finisher cover becomes open during paper is running. Paper is remaining in paths at power on.	-
92	Eject paper sensor non-arrival jam (document finisher)	In the straight mode, the eject paper sensor (EPS) is not turned on even if a specified time has elapsed after the paper entry sensor (PES) was turned on.	-

Section	Description	Conditions	Specified time
Optional finisher	93 Reverse sensor jam (document finisher)	The reverse sensor (SBS) does not turn on within specified time of paper entry sensor (PES) turning on (unfinished reversing canceled).	719 ms
		The reverse sensor (SBS) is not turned on within specified time (unfinished reversing set).	431 ms
		The reverse sensor (SBS) is not turned off within specified time its turning on (resident reversing canceled).	3000 ms
		The reverse sensor (SBS) is not turned off within specified time its turning on (resident reversing set).	700 ms
	94 Paper entry sensor stay/remaining jam (document finisher)	The paper entry sensor (PES) is not turned off within specified time its turning on.	2250 ms
	95 Paper conveying sensor jam (document finisher)	The paper conveying sensor (PCS) is not turned off within specified time its turning on (reversing canceled).	2250 ms
		The paper conveying sensor (PCS) is not turned off within specified time its turning on (reversing set).	656 ms
	96 Jam between the built-in finisher and machine (built-in finisher)	The paper conveying switch (PCSW) is not turned on within the specified time when paper is ejected to the finisher tray from the process table.	2000 ms

(3) Paper misfeeds

Problem	Causes/check procedures	Corrective measures
(1) A paper jam in the paper feed, conveying or eject section is indicated as soon as the main power switch is turned on.	A piece of paper torn from copy paper is caught around feed switch 1/2/3, registration switch, eject switch or feedshift switch.	Check visually and remove it, if any.
	Defective switch.	Run maintenance item U031 and turn switch on and off manually. Replace the switch if indication of the corresponding switch on the touch panel is not displayed in reverse. Feed switch 1/2/3, registration switch, eject switch, feedshift switch
(2) A paper jam in the paper feed section is indicated during copying (no paper feed from cassette 1). Jam code 10	Paper is extremely curled.	Change the paper.
	Check if the paper feed pulley, separation pulley or forwarding pulley of the cassette 1 are deformed.	Check visually and replace any deformed pulleys.
	Broken feed switch 1 actuator.	Check visually and replace switch.
	Defective feed switch 1.	Run maintenance item U031 and turn feed switch 1 on and off manually. Replace the switch if indication of the corresponding switch on the touch panel is not displayed in reverse.
	Check if the paper feed clutch 1 malfunctions.	Run maintenance item U032 and select the paper feed clutch 1 on the touch panel to be turned on and off. Check the status and remedy if necessary.
	Electrical problem with the paper feed clutch 1.	Check (see page 1-4-42).
(3) A paper jam in the paper feed section is indicated during copying (no paper feed from cassette 2). Jam code 11	Paper is extremely curled.	Change the paper.
	Check if the paper feed pulley, separation pulley or forwarding pulley of the cassette 2 are deformed.	Check visually and replace any deformed pulleys.
	Broken feed switch 2 actuator.	Check visually and replace switch.
	Defective feed switch 2.	Run maintenance item U031 and turn feed switch 2 on and off manually. Replace feed switch 2 if indication of the corresponding switch on the touch panel is not displayed in reverse.
	Check if the paper feed clutch 2 malfunctions.	Run maintenance item U032 and select the paper feed clutch 2 on the touch panel to be turned on and off. Check the status and remedy if necessary.
	Electrical problem with the paper feed clutch 2.	Check (see page 1-4-42).

Problem	Causes/check procedures	Corrective measures
(4) A paper jam in the paper feed section is indicated during copying (no paper feed from optional cassette 3). Jam code 12	Paper is extremely curled.	Change the paper.
	Check if the paper feed pulley, forwarding pulley and separation pulley of optional cassette 3 are deformed.	Check visually and replace any deformed pulleys.
	Broken feed switch 3 actuator.	Check visually and replace switch.
	Defective feed switch 3.	Run maintenance item U031 and turn feed switch 3 on and off manually. Replace feed switch 3 if indication of the corresponding switch on the touch panel is not displayed in reverse.
	Check if PF paper feed clutch 1 malfunctions.	Run maintenance item U247 and select PF paper feed clutch 1 on the touch panel to be turned on and off. Check the status and remedy if necessary.
	Electrical problem with PF paper feed clutch 1.	Check (see service manual of paper feeder).
(5) A paper jam in the paper feed section is indicated during copying (no paper feed from optional cassette 4). Jam code 13	Paper is extremely curled.	Change the paper.
	Check if the paper feed pulley, forwarding pulley and separation pulley of optional cassette 4 are deformed.	Check visually and replace any deformed pulleys.
	Broken PF feed switch actuator.	Check visually and replace switch.
	Defective PF feed switch.	With 5 V DC present at YC2-8 on the PF main PWB, check if YC2-7 on the PF main PWB remains low when the PF feed switch is turned on and off. If it does, replace the PF feed switch.
	Check if PF paper feed clutch 2 malfunctions.	Run maintenance item U247 and select PF paper feed clutch 2 on the touch panel to be turned on and off. Check the status and remedy if necessary.
	Electrical problem with PF paper feed clutch 2.	Check (see service manual of paper feeder).
(6) A paper jam in the paper feed section is indicated during copying (no paper feed from MP tray). Jam code 14	Paper is extremely curled.	Change the paper.
	Check if the MP paper feed pulley, MP forwarding pulley and MP separation pulley are deformed.	Check visually and replace any deformed pulleys.
	Broken MP feed switch actuator.	Check visually and replace switch.
	Defective MP feed switch.	Run maintenance item U031 and turn MP feed switch on and off manually. Replace the switch if indication of the corresponding switch on the touch panel is not displayed in reverse.
	Check if the MP paper feed clutch malfunctions.	Run maintenance item U032 and select MP paper feed clutch on the touch panel to be turned on and off. Check the status and remedy if necessary.
	Electrical problem with the MP paper feed clutch.	Check (see page 1-4-42).

Problem	Causes/check procedures	Corrective measures
(7) A paper jam in the paper feed section is indicated during copying (jam in vertical paper conveying section). Jam code 18	Broken feed switch 1/2/3 actuator.	Check visually and replace switch.
	Defective switch.	Run maintenance item U031 and turn following switch on and off manually. Replace the switch if indication of the corresponding switch on the touch panel is not displayed in reverse. Feed switch 1/2/3
	Defective feed pulleys or feed rollers.	Check visually and replace.
(8) A paper jam in the paper feed section is indicated during copying (jam in optional paper feeder vertical paper conveying section). Jam code 19	Broken feed switch 3 actuator.	Check visually and replace switch.
	Defective feed switch 3.	Run maintenance item U031 and turn feed switch 3 on and off manually. Replace the switch if indication of the corresponding switch on the touch panel is not displayed in reverse.
	Broken PF feed switch actuator.	Check visually and replace switch.
	Defective PF feed switch.	With 5 V DC present at YC2-8 on the PF main PWB, check if YC2-7 on the PF main PWB remains low when the PF feed switch is turned on and off. If it does, replace the PF feed switch.
(9) A paper jam in the paper feed section is indicated during copying (jam in MP tray paper conveying section). Jam code 20	Broken MP feed switch or registration switch actuator.	Check visually and replace switch.
	Defective switch.	Run maintenance item U031 and turn following switch on and off manually. Replace the switch if indication of the corresponding switch on the touch panel is not displayed in reverse. MP feed switch, registration switch
(10) A paper jam in the paper feed section is indicated during copying (multiple sheets in paper feed section). Jam code 21	Broken feed switch 1/2/3 actuator.	Check visually and replace switch.
	Defective switch.	Run maintenance item U031 and turn switch on and off manually. Replace the switch if indication of the corresponding switch on the touch panel is not displayed in reverse. Feed switch 1/2/3
	Broken PF feed switch actuator.	Check visually and replace switch.
	Defective PF feed switch.	With 5 V DC present at YC2-8 on the PF main PWB, check if YC2-7 on the PF main PWB remains low when the PF feed switch is turned on and off. If it does, replace the PF feed switch.
	Check if the clutch malfunctions.	Run maintenance item U032 and select following clutch on the touch panel to be turned on and off. Check the status and remedy if necessary. paper feed clutch 1/2
	Electrical problem with clutch.	Check (see page 1-4-42).
	Check if PF paper feed clutch 1 malfunctions.	Run maintenance item U247 and select PF paper feed clutch 1 on the touch panel to be turned on and off. Check the status and remedy if necessary.
	Electrical problem with PF paper feed clutch 1.	Check (see service manual of paper feeder).
Defective feed pulleys or feed rollers.	Check visually and replace.	

Problem	Causes/check procedures	Corrective measures
(11) A paper jam in the paper feed section is indicated during copying (multiple sheets in MP tray conveying section). Jam code 23	Broken MP feed switch actuator.	Check visually and replace switch.
	Defective switch.	Run maintenance item U031 and turn switch on and off manually. Replace the switch if indication of the corresponding switch on the touch panel is not displayed in reverse. MP feed switch
(12) A paper jam in the paper conveying section is indicated during copying (jam in registration/transfer section). Jam code 30	Broken feed switch 1, registration switch or MP feed switch actuator.	Check visually and replace switch.
	Defective switch.	Run maintenance item U031 and turn switch on and off manually. Replace the switch if indication of the corresponding switch on the touch panel is not displayed in reverse. Feed switch 1, registration switch, MP feed switch
	The contact between the right and left registration rollers is not correct.	Check visually and replace.
(13) A paper jam in the fuser section is indicated during copying (jam in fuser section). Jam codes 40 to 44 and 47	Broken eject switch or feedshift switch actuator.	Check visually and replace switch.
	Defective switch.	Run maintenance item U031 and turn switch on and off manually. Replace the switch if indication of the corresponding switch on the touch panel is not displayed in reverse. Eject switch, feedshift switch
	Check if the registration clutch malfunctions.	Run maintenance item U032 and select the registration clutch on the touch panel to be turned on and off. Check the status and remedy if necessary.
	Electrical problem with the registration clutch.	Check (see page 1-4-42).
(14) A paper jam in the eject section is indicated during copying (jam in eject section). Jam code 50	Broken eject switch or registration switch actuator.	Check visually and replace switch.
	Defective switch.	Run maintenance item U031 and turn switch on and off manually. Replace the switch if indication of the corresponding switch on the touch panel is not displayed in reverse. Registration switch, eject switch
	Check if the registration clutch malfunctions.	Run maintenance item U032 and select the registration clutch on the touch panel to be turned on and off. Check the status and remedy if necessary.
	Electrical problem with the registration clutch.	Check (see page 1-4-42).

Problem	Causes/check procedures	Corrective measures
(15) A paper jam in the eject section is indicated during copying (jam in optional job separator eject section). Jam code 51	Broken feedshift switch or job separator eject switch actuator.	Check visually and replace switch.
	Defective switch.	Run maintenance item U031 and turn switch on and off manually. Replace the switch if indication of the corresponding switch on the touch panel is not displayed in reverse. Feedshift switch, job separator eject switch
(16) A paper jam in the feedshift section is indicated during copying (jam in feedshift section). Jam code 52	Check if the feedshift solenoid malfunctions.	Run maintenance item U033 and select the feedshift solenoid on the touch panel to be turned on and off. Check the status and remedy if necessary.
	Electrical problem with the feedshift solenoid.	Check (see page 1-4-42).
	Broken feedshift switch actuator.	Check visually and replace switch.
	Defective switch.	Run maintenance item U031 and turn switch on and off manually. Replace the switch if indication of the corresponding switch on the touch panel is not displayed in reverse. Feedshift switch
	Check if the registration clutch malfunctions.	Run maintenance item U032 and select the registration clutch on the touch panel to be turned on and off. Check the status and remedy if necessary.
	Electrical problem with the registration clutch.	Check (see page 1-4-42).
(17) A paper jam in the duplex section is indicated during copying (jam in duplex paper conveying section 1). Jam code 60	Broken feedshift switch or duplex paper conveying switch actuator.	Check visually and replace switch.
	Defective switch.	Run maintenance item U031 and turn switch on and off manually. Replace the switch if indication of the corresponding switch on the touch panel is not displayed in reverse. Feedshift switch, duplex paper conveying switch
(18) A paper jam in the duplex section is indicated during copying (jam in duplex paper conveying section 2). Jam code 61	Broken duplex paper conveying switch or registration switch actuator.	Check visually and replace switch.
	Defective switch.	Run maintenance item U031 and turn switch on and off manually. Replace the switch if indication of the corresponding switch on the touch panel is not displayed in reverse. Duplex paper conveying switch, registration switch

Problem	Causes/check procedures	Corrective measures
(19) An original jams in optional DP is indicated during copying (no original feed). Jam code 70	Defective DP timing switch.	Run maintenance item U244 and turn the DP timing switch on and off manually. Replace the switch if indication of the corresponding switch on the touch panel is not displayed in reverse.
	Check if the original feed motor malfunctions.	Run maintenance item U243 and select the original feed motor on the touch panel to be turned on and off. Check the status and remedy if necessary.
(20) An original jams in optional DP is indicated during copying (a jam in the original conveying section 1). Jam code 71	Defective DP timing switch.	Run maintenance item U244 and turn the DP timing switch on and off manually. Replace the switch if indication of the corresponding switch on the touch panel is not displayed in reverse.
(21) An original jams in optional DP is indicated during copying (a jam in the original conveying section 2). Jam code 72	Defective DP timing switch.	Run maintenance item U244 and turn the DP timing switch on and off manually. Replace the switch if indication of the corresponding switch on the touch panel is not displayed in reverse.
	Check if the original conveying motor malfunctions.	Run maintenance item U243 and select the original conveying motor on the touch panel to be turned on and off. Check the status and remedy if necessary.
(22) An original jams in optional DP is indicated during copying (a jam in the original switchback section). Jam code 73	Defective DP timing switch.	Run maintenance item U244 and turn the DP timing switch on and off manually. Replace the switch if indication of the corresponding switch on the touch panel is not displayed in reverse.
	Check if the original switchback motor malfunctions.	Run maintenance item U243 and select the original switchback motor on the touch panel to be turned on and off. Check the status and remedy if necessary.
(23) An original jams in optional DP is indicated during copying (a jam in the original switchback/feed section). Jam code 74	Defective DP timing switch.	Run maintenance item U244 and turn the DP timing switch on and off manually. Replace the switch if indication of the corresponding switch on the touch panel is not displayed in reverse.
	Check if the original switchback motor malfunctions.	Run maintenance item U243 and select the original switchback motor on the touch panel to be turned on and off. Check the status and remedy if necessary.
(24) An original jams in optional DP is indicated during copying (a jam in the original switchback/conveying section). Jam code 75	Defective switch.	Run maintenance item U244 and turn switch on and off manually. Replace the switch if indication of the corresponding switch on the touch panel is not displayed in reverse. DP timing switch, original switchback switch
(25) A paper jam in optional document finisher is indicated during copying (jam between finisher and machine). Jam code 80	Defective paper entry sensor.	With 5 V DC present at CN14-1 and CN14-3 on the finisher main PWB, check if CN14-2 and CN14-4 on the finisher main PWB remains low or high when the paper entry sensor is turned on and off. If it does, replace the paper entry sensor.

Problem	Causes/check procedures	Corrective measures
(26) A paper jam in optional document finisher is indicated during copying (paper jam during paper insertion to the finisher). Jam code 81	Document finisher	
	Extremely curled paper.	Change the paper.
	Defective paper entry sensor.	With 5 V DC present at CN14-1 and CN14-3 on the finisher main PWB, check if CN14-2 and CN14-4 on the finisher main PWB remains low or high when the paper entry sensor is turned on and off. If it does, replace the paper entry sensor.
	Defective finisher main PWB.	Replace the finisher main PWB and check for correct operation.
	Built-in finisher	
	Extremely curled paper.	Change the paper.
	Defective paper conveying switch.	With 5 V DC present at YC2-23 on the finisher control PWB, check if YC2-21 on the finisher control PWB remains low or high when the paper conveying switch is turned on and off. If it does, replace the paper conveying switch.
	Check if the feedshift roller or feedshift pulley is deformed.	Check and remedy.
(27) A paper jam in optional document finisher is indicated during copying (finisher stapler jam). Jam code 82	Document finisher	
	Defective staple home position sensor.	With 5 V DC present at CN10-2 on the finisher main PWB, check if CN10-5 on the finisher main PWB remains low or high. If it does, replace the stapler section.
	Built-in finisher	
	The stapler is blocked with a staple.	Remove the stapler cartridge, and check the cartridge and the stapling section of the stapler. Remove the staple if any.
	Defective stapler section.	With 5 V DC present at YC2-24 on the finisher control PWB, check if YC2-19 on the finisher control PWB remains low or high. If it does, replace the stapler section.
(28) A paper jam in optional document finisher is indicated during copying (eject sensor stay jam). Jam code 83	Document finisher	
	Defective eject sensor.	With 5 V DC present at CN5-4 on the finisher main PWB, check if CN5-6 on the finisher main PWB remains low or high when the eject sensor is turned on and off. If it does, replace the eject sensor.
	Check if the paper conveying motor malfunctions.	Check and remedy.
	Check if the eject roller and eject pulley contact each other.	Check and remedy.
	Check if the eject guide is deformed.	Check and remedy.
	Defective finisher main PWB.	Replace the finisher main PWB and check for correct operation.

Problem	Causes/check procedures	Corrective measures
(28) A paper jam in optional document finisher is indicated during copying (eject sensor stay jam). Jam code 83	Built-in finisher	
	Defective paper conveying switch.	With 5 V DC present at YC2-23 on the finisher control PWB, check if YC2-21 on the finisher control PWB remains low when the paper conveying switch is turned on and off. If it does, replace the paper conveying switch.
	Check if the eject roller or eject pulley is deformed.	Check and remedy.
(29) A paper jam in optional document finisher is indicated during copying (eject sensor non-arrival jam). Jam code 92	Defective eject sensor.	With 5 V DC present at CN5-4 on the finisher main PWB, check if CN5-6 on the finisher main PWB remains low or high when the eject sensor is turned on and off. If it does, replace the eject sensor.
	Check if the paper conveying motor malfunctions.	Check.
	Check if the eject roller and eject pulley contact each other.	Check and remedy.
	Check if the eject guide is deformed.	Check and remedy.
	Defective finisher main PWB.	Replace the finisher main PWB and check for correct operation.
(30) A paper jam in optional document finisher is indicated during copying (reverse sensor jam). Jam code 93	Defective reverse sensor.	With 5 V DC present at CN14-5 on the finisher main PWB, check if CN14-7 on the finisher main PWB remains low or high when the reverse sensor is turned on and off. If it does, replace the reverse sensor.
	Check if the reverse motor malfunctions.	Check.
	Check if the reverse roller and reverse pulley contact each other.	Check and remedy.
	Check if the reverse guide is deformed.	Check and remedy.
	Defective finisher main PWB.	Replace the finisher main PWB and check for correct operation.
(31) A paper jam in optional document finisher is indicated during copying (paper entry sensor stay jam). Jam code 94	Extremely curled paper.	Change the paper.
	Defective paper entry sensor.	With 5 V DC present at CN14-1 and CN14-3 on the finisher main PWB, check if CN14-2 and CN14-4 on the main PCB remains low or high when the paper entry sensor is turned on and off. If it does, replace the paper entry sensor.
	Check if the paper entry guide is deformed.	Check and remedy.
	Defective finisher main PWB.	Replace the finisher main PWB and check for correct operation.

Problem	Causes/check procedures	Corrective measures
(32) A paper jam in optional document finisher is indicated during copying (paper conveying sensor jam). Jam code 95	Defective paper conveying sensor.	With 5 V DC present at CN4-4 on the finisher main PWB, check if CN4-6 on the finisher main PWB remains low or high when the paper conveying sensor is turned on and off. If it does, replace the paper conveying sensor.
	Check if the paper conveying motor malfunctions.	Check.
	Check if the paper conveying roller and paper conveying pulley contact each other.	Check and remedy.
	Check if the paper conveying guide is deformed.	Check and remedy.
	Defective finisher main PWB.	Replace the finisher main PWB and check for correct operation.
(33) A paper jam in optional built-in finisher is indicated during copying (jam between finisher and machine). Jam code 96	Defective paper conveying switch.	With 5 V DC present at YC2-23 on the finisher control PWB, check if YC2-21 on the finisher control PWB remains low when the paper conveying switch is turned on and off. If it does, replace the paper conveying switch.
	Check if the eject roller or eject pulley is deformed.	Check and remedy.

1-4-2 Self-diagnosis

(1) Self-diagnostic function

This unit is equipped with a self-diagnostic function. When a problem is detected, copying is disabled and the problem displayed as a code consisting of C followed by a number, indicating the nature of the problem.

A message is also displayed requesting the user to call for service.

After removing the problem, the self-diagnostic function can be reset by turning safety switches off and back on.

List of system errors

When an unexpected error is detected for some reason, a system error will be indicated. After a system error is indicated, the error can be cleared by turning the power switch off and then on. If the error is detected continuously, however, perform the operation shown in Table 1-4-1. If a system error occurs frequently, a fault may have occurred. Check the details of the C call to take proper measures.

System error	Contents	Operation
0420	Optional paper feeder communication problem	System error → service call → partial operation
4200	BD initialization problem	System error → Normal service call processing
8800	Document finisher communication error (optional 3000-sheet document finisher)	System error → service call → partial operation
9000	Optional DP communication problem	System error → service call → partial operation

Table 1-4-1

In addition, it is a system error if the following error code is displayed. When an error has occurred, clear the error by turning the main power switch off then on.

CF1XX, CF2XX, CF3XX, CF4XX, CF5XX, CF6XX, CF7XX, CFAXX, CFBXX, 0xFBXX

Partial operation control

If one of the following service codes is detected, partial operation control will be activated. Take actions to clear the cause of the trouble and perform maintenance item U906 to reset partial operation control.

Code	Contents
C0840	Faults of RTC
C1010	Lift motor 1 error
C1020	Lift motor 2 error
C1030	PF lift motor 1 error (optional paper feeder)
C1040	PF lift motor 2 error (optional paper feeder)
C2600	PF paper drive motor error (optional paper feeder)
C8030	Tray upper limit detection problem (optional document finisher)
C8040	Belt problem (optional document finisher)
C8140	Tray elevation motor problem (optional document finisher)
C8170	Finisher front side registration motor problem (optional built-in finisher)
C8180	Finisher rear side registration motor problem (optional built-in finisher)
C8190	Finisher trailing edge registration motor problem (optional built-in finisher)
C8210	Stapler problem (optional document finisher)
	Finisher stapler problem (optional built-in finisher)
C8320	Adjustment motor 2 problem (optional document finisher)
C8330	Adjustment motor 1 problem (optional document finisher)
C8350	Roller motor problem (optional document finisher)

Code	Contents
C8360	Slide motor problem (optional document finisher)
C8440	Sensor adjusting problem (optional document finisher)
C8460	EEPROM problem (optional document finisher)
C9060	DP EEPROM error (optional DP)

Measures against the service codes detecting fuser problems

If one of the following service codes is detected, take actions to clear the cause of the trouble and perform maintenance item U163 to reset the service code.

Code	Contents
C6000	Fuser heater break
C6020	Abnormally high fuser thermistor center temperature
C6050	Abnormally low fuser thermistor center temperature
C6120	Abnormally high fuser thermistor edge temperature
C6150	Abnormally low fuser thermistor edge temperature
C6400	Zero-cross signal error
C6420	Fuser unit fuse cut problem

(2) Self diagnostic codes

Code	Contents	Remarks	
		Causes	Check procedures/corrective measures
C0030	Fax control PWB system problem Processing with the fax software was disabled due to a hardware or software problem.	Defective fax control PWB.	Replace the fax control PWB and verify the operation.
C0060	Main PWB type mismatch error	Defective PWB.	Run maintenance item U935 to contact the Service Administrative Division.
C0070	Abnormal detection of fax control PWB incompatibility In the initial communication with the fax control PWB, any normal communication command is not transmitted.	Defective fax software.	Install the fax software.
		Defective fax control PWB.	Replace the fax control PWB and verify the operation.
C0100	Backup memory (EEPROM) device problem (Main PWB) Reading from or writing to EEPROM cannot be performed.	Defective main PWB.	Replace the main PWB and check for correct operation.
		Device damage of EEPROM.	Contact the Service Administrative Division.
C0120	MAC address data error For data in which the MAC address is invalid.	Defective main PWB.	Replace the main PWB and check for correct operation.
C0150	Backup memory (EEPROM) device problem (Engine PWB) Reading from or writing to EEPROM cannot be performed.	Defective engine PWB.	Replace the engine PWB and check for correct operation.
		Device damage of EEPROM.	Contact the Service Administrative Division.
C0160	Backup memory (EEPROM) data problem (Engine PWB) Reading data from EEPROM is abnormal. Read and write data does not match 5 times continuously.	Data damage of EEPROM.	Contact the Service Administrative Division.
C0170	Copy counts problem A checksum error is detected in the main and engine backup memories for the copy counters.	Data damage of EEPROM.	Contact the Service Administrative Division.
		Defective PWB.	Replace the main PWB or engine PWB and check for correct operation.
C0180	Machine number mismatch error Machine number of main PWB and engine PWB does not match.	Data damage of EEPROM.	Contact the Service Administrative Division.
C0320	Power CPU communication problem The engine PWB and the power CPU are unable to communicate with each other.	Defective engine PWB.	Replace the engine PWB and check for correct operation.
C0420	Optional paper feeder communication problem The engine PWB and the paper feeder are unable to communicate with each other.	Poor contact in the connector terminals.	Check the connection of connector YC22 on the engine PWB and the connector on the paper feeder main PWB, and the continuity across the connector terminals. Repair or replace if necessary.
		Defective PWB.	Replace the engine PWB or paper feeder main PWB and check for correct operation.

Code	Contents	Remarks	
		Causes	Check procedures/corrective measures
C0620	FAX image DIMM problem DIMM is not installed correctly. DIMM cannot be accessed.	DIMM installed incorrectly.	Check if the DIMM is inserted into the socket on the main PWB correctly.
		Defective main PWB.	Replace the main PWB and check for correct operation.
C0630	DMA problem DMA transmission of image data does not complete within the specified period of time.	Poor contact in the connector terminals.	Check the connection the signal cable and the main PWB, and the continuity across the connector terminals. Repair or replace if necessary.
		Defective main PWB.	Replace the main PWB and check for correct operation.
C0640	Hard disk drive problem The hard disk cannot be accessed.	Poor contact in the connector terminals.	Check the connection of connector YC49 on the main PWB and the connector on the hard disk. Repair or replace if necessary.
		Defective hard disk.	Run U024 (HDD formatting) without turning the power off to initialize the hard disk. Replace the hard disk drive and check for correct operation if the problem is still detected after initialization.
		Defective main PWB.	Replace the main PWB and check for correct operation.
C0650	FAX image DIMM check problem Improper DIMM is installed.	DIMM installed incorrectly.	Check if the DIMM is inserted into the socket on the main PWB correctly.
		DIMM of another machine is installed.	Perform maintenance mode U671 (RECOVERY FAX DIMM).
		Defective main PWB.	Replace the main PWB and check for correct operation.
C0800	Image processing problem JAM05 is detected twice.	Defective main PWB.	Replace the main PWB and check for correct operation.
C0830	Fax control PWB flash program area checksum error A checksum error occurred with the program of the fax control PWB.	Defective fax software.	Install the fax software.
		Defective fax control PWB.	Replace the fax control PWB and verify the operation.
C0840	Faults of RTC The time is judged to go back based on the comparison of the RTC time and the current time or five years or more have passed.	Defective main PWB.	Replace the main PWB and check for correct operation.
		The battery is disconnected from the main PWB.	Check visually and remedy if necessary.
C0870	Fax control PWB to main PWB high capacity data transfer problem High-capacity data transfer between the fax control PWB and the scanner MIP PWB was not normally performed even if the data transfer was retried 10 times.	Poor contact in the connector terminals.	Check the connection of connector on the interface PWB and the connector on the fax control PWB, and the continuity across the connector terminals. Repair or replace if necessary.
		Defective PWB.	Replace the fax control PWB or main PWB and check for correct operation.

Code	Contents	Remarks	
		Causes	Check procedures/corrective measures
C0920	Fax file system error The backup data is not retained for file system abnormality of flash memory of the fax control PWB.	Defective fax control PWB.	Replace the fax control PWB and verify the operation.
C1010	Lift motor 1 error After cassette 1 is inserted, lift switch 1 does not turn on within 12 s. This error is detected four times successively.	Poor contact in the connector terminals.	Check the connection of connector of lift motor 1 and the connector YC23 on the engine PWB, and the continuity across the connector terminals. Repair or replace if necessary.
		Broken gears or couplings of lift motor 1.	Replace lift motor 1.
		Defective lift motor 1.	Check for continuity across the coil. If none, replace lift motor 1.
		Poor contact in the connector terminals.	Check the connection of connector of lift switch 1 and the connector YC23 on the engine PWB, and the continuity across the connector terminals. Repair or replace if necessary.
		Defective lift switch 1.	Check if YC23-B12 on the engine PWB goes low when lift switch 1 is turned off. If not, replace lift switch 1.
		Defective engine PWB.	Replace the engine PWB and check for correct operation.
C1020	Lift motor 2 error After cassette 2 is inserted, lift switch 2 does not turn on within 12 s. This error is detected four times successively.	Poor contact in the connector terminals.	Check the connection of connector of lift motor 2 and the connector YC23 on the engine PWB, and the continuity across the connector terminals. Repair or replace if necessary.
		Broken gears or couplings of lift motor 2.	Replace lift motor 2.
		Defective lift motor 2.	Check for continuity across the coil. If none, replace lift motor 2.
		Poor contact in the connector terminals.	Check the connection of connector of lift switch 2 and the connector YC23 on the engine PWB, and the continuity across the connector terminals. Repair or replace if necessary.
		Defective lift switch 2.	Check if YC23-A5 on the engine PWB goes low when lift switch 2 is turned off. If not, replace lift switch 2.
		Defective engine PWB.	Replace the engine PWB and check for correct operation.

Code	Contents	Remarks	
		Causes	Check procedures/corrective measures
C1030	PF lift motor 1 error (optional paper feeder) After cassette 3 is inserted, PF lift switch 1 does not turn on within 12 s. This error is detected four times successively.	Poor contact in the connector terminals.	Check the connection of connector YC22 on the engine PWB and the connector on the PF main PWB, and the continuity across the connector terminals. Repair or replace if necessary.
		Broken gears or couplings of PF lift motor 1.	Replace PF lift motor 1.
		Defective PF lift motor 1.	Check for continuity across the coil. If none, replace PF lift motor 1.
		Defective PF lift switch 1.	Check if YC1-5 on the PF main PWB goes low when PF lift switch 1 is turned off. If not, replace PF lift switch 1.
C1040	PF lift motor 2 error (optional paper feeder) After cassette 4 is inserted, PF lift switch 2 does not turn on within 12 s. This error is detected four times successively.	Poor contact in the connector terminals.	Check the connection of connector YC22 on the engine PWB and the connector on the PF main PWB, and the continuity across the connector terminals. Repair or replace if necessary.
		Broken gears or couplings of PF lift motor 2.	Replace PF lift motor 2.
		Defective PF lift motor 2.	Check for continuity across the coil. If none, replace PF lift motor 2.
		Defective PF lift switch 2.	Check if YC1-7 on the PF main PWB goes low when PF lift switch 2 is turned off. If not, replace PF lift switch 2.
C2000	Main motor problem Stable OFF is detected for 1 s continuously after main motor stability.	Poor contact in the connector terminals.	Check the connection of connector YC10 on the engine PWB and the connector on the main motor, and the continuity across the connector terminals. Repair or replace if necessary.
		Defective drive transmission system.	Check if the rollers and gears rotate smoothly. If not, grease the bushings and gears. Check for broken gears and replace if any.
		Defective main motor.	Replace the main motor.
		Defective engine PWB.	Replace the engine PWB and check for correct operation.

Code	Contents	Remarks	
		Causes	Check procedures/corrective measures
C2200	Drum motor problem Stable OFF is detected for 1 s continuously after drum motor stability.	Poor contact in the connector terminals.	Check the connection of connector YC10 on the engine PWB and the connector on the drum motor, and the continuity across the connector terminals. Repair or replace if necessary.
		Defective drive transmission system.	Check if the rollers and gears rotate smoothly. If not, grease the bushings and gears. Check for broken gears and replace if any.
		Defective drum motor.	Replace the drum motor.
		Defective engine PWB.	Replace the engine PWB and check for correct operation.
C2500	Paper feed motor error Stable OFF is detected for 1 s continuously after paper feed motor stability.	Poor contact in the connector terminals.	Check the connection of connector YC10 on the engine PWB and the connector on the paper feed motor, and the continuity across the connector terminals. Repair or replace if necessary.
		Defective drive transmission system.	Check if the rollers and gears rotate smoothly. If not, grease the bushings and gears. Check for broken gears and replace if any.
		Defective paper feed motor.	Replace the paper feed motor.
		Defective engine PWB.	Replace the engine PWB and check for correct operation.
C2600	PF paper drive motor error (optional paper feeder) The lock signal of the motor is detected above 500 ms.	Poor contact in the connector terminals.	Check the connection of connector YC22 on the engine PWB and the connector on the PF main PWB, and the continuity across the connector terminals. Repair or replace if necessary.
		Defective drive transmission system.	Check if the rollers and gears rotate smoothly. If not, grease the bushings and gears. Check for broken gears and replace if any.
		Defective PF paper drive motor.	Replace the PF paper drive motor.
		Defective PWB.	Replace the PF main PWB or engine PWB and check for correct operation.

Code	Contents	Remarks	
		Causes	Check procedures/corrective measures
C3100	Scanner carriage problem The home position is not correct when the power is turned on or at the start of copying using the table.	Poor contact in the connector terminals.	Check the connection of connector YC6 on the scanner PWB and the connector of the home position switch, and the connection of connector YC3 on the scanner PWB and the connector on the scanner motor and the continuity across the connector terminals. Repair or replace if necessary.
		Defective home position switch.	Replace the scanner home position switch.
		Defective scanner motor.	Replace the scanner motor.
		The mirror frame, exposure lamp, or scanner wire is defective.	Check if the mirror frames and exposure lamp are on the rail. And check the scanner wire winds correctly.
		Defective PWB.	Replace the scanner PWB or main PWB and check for correct operation.
C3200	Exposure lamp problem When input value at the time of exposure lamp illumination does not exceed the threshold value between 5 s.	Poor contact in the connector terminals.	Check the connection of connector YC5 on the scanner PWB and the connector on the inverter PWB, and the continuity across the connector terminals. Repair or replace if necessary.
		Defective exposure lamp.	Replace the exposure lamp.
		Incorrect shading position.	Adjust the position of the contact glass (shading plate). If the problem still occurs, replace the home position switch.
		Defective PWB.	Replace the scanner PWB or inverter PWB and check for correct operation.
C3300	Optical system (AGC) problem After AGC, correct input is not obtained at CCD.	Poor contact in the connector terminals.	Check the connection of connector YC26 on the main PWB and the connector on the CCD PWB, and the continuity across the connector terminals. Repair or replace if necessary.
		Defective exposure lamp.	Replace the exposure lamp.
		Defective PWB.	Replace the main PWB or CCD PWB and check for correct operation.
C3500	Communication error between scanner and SHD An error code is detected.	Poor contact in the connector terminals.	Check the connection of connector YC26 on the main PWB and the connector on the CCD PWB, and the continuity across the connector terminals. Repair or replace if necessary.
		Defective PWB.	Replace the main PWB or CCD PWB and check for correct operation.

Code	Contents	Remarks	
		Causes	Check procedures/corrective measures
C3900	Backup memory read/write problem (scanner PWB) Read and write data does not match.	Defective backup RAM or PWB.	Replace the scanner PWB and check for correct operation.
C3910	Backup memory data problem (scanner PWB) Data in the specified area of the backup memory does not match the specified values.	Defective backup RAM or PWB.	Replace the scanner PWB and check for correct operation.
C4000	Polygon motor synchronization problem The polygon motor does not reach the stable speed within 20 s of the START signal turning on.	Poor contact in the connector terminals.	Check the connection of connector YC36 on the engine PWB and laser scanner unit, and the continuity across the connector terminals. Repair or replace if necessary.
		Defective polygon motor.	Replace the laser scanner unit.
		Defective engine PWB.	Replace the engine PWB and check for correct operation.
C4010	Polygon motor steady-state problem Stable OFF is detected for 5 s continuously after polygon motor stability.	Poor contact in the connector terminals.	Check the connection of connector YC36 on the engine PWB and laser scanner unit, and the continuity across the connector terminals. Repair or replace if necessary.
		Defective polygon motor.	Replace the laser scanner unit.
		Defective engine PWB.	Replace the engine PWB and check for correct operation.
C4200	BD initialization problem ASIC detects a BD error A for 4 s after the polygon motor rotation has been stabilized.	Poor contact in the connector terminals.	Check the connection of connector YC36 on the engine PWB and laser scanner unit, and the continuity across the connector terminals. Repair or replace if necessary.
		Defective polygon motor.	Replace the laser scanner unit.
		Defective engine PWB.	Replace the engine PWB and check for correct operation.
C6000	Fuser heater break Fuser thermistor 1 detected less than 40°C/104°F for 14 s during warm-up and ready in. Fuser thermistor 2 detected less than 70°C/158°F for 14 s during warm-up and ready in.	Defective fuser heater 1 or 2.	Replace the fuser heater 1 or 2.
		Installation defectiveness on fuser thermistor 1 or 2.	Check the mounting state of the fuser thermistor 1 or 2. If any problem is found, repair it.
		Defective fuser thermostat.	Replace the fuser thermostat.
		Defective PWB.	Replace the power source PWB or engine PWB and check for correct operation.

Code	Contents	Remarks	
		Causes	Check procedures/corrective measures
C6020	Abnormally high fuser thermistor center temperature Fuser thermistor 2 is detected 230°C/ 446°F or more for 40 ms.	Installation defectiveness on fuser thermistor 2.	Check the mounting state of the fuser thermistor 2. If any problem is found, repair it.
		Defective fuser thermistor 2.	Replace the fuser thermistor 2.
		Defective engine PWB.	Replace the engine PWB and check for correct operation.
C6050	Abnormally low fuser thermistor center temperature Fuser thermistor 1 is detected 100°C/ 212°F less than 1 s continuously during copying.	Defective fuser heater 1 or 2.	Replace the fuser heater 1 or 2.
		Installation defectiveness on fuser thermistor 2.	Check the mounting state of the fuser thermistor 2. If any problem is found, repair it.
		Defective PWB.	Replace the power source PWB or engine PWB and check for correct operation.
C6120	Abnormally high fuser thermistor edge temperature Fuser thermistor 1 is detected 240°C/ 464°F or more for 40 ms.	Installation defectiveness on fuser thermistor 1.	Check the mounting state of the fuser thermistor 1. If any problem is found, repair it.
		Defective fuser thermistor 1.	Replace the fuser thermistor 1.
		Defective engine PWB.	Replace the engine PWB and check for correct operation.
C6150	Abnormally low fuser thermistor edge temperature Fuser thermistor 1 is detected 80°C/ 176°F less than 1 s continuously during copying.	Defective fuser heater 1 or 2.	Replace the fuser heater 1 or 2.
		Installation defectiveness on fuser thermistor 1.	Check the mounting state of the fuser thermistor 1. If any problem is found, repair it.
		Defective PWB.	Replace the power source PWB or engine PWB and check for correct operation.
C6400	Zero-cross signal error While fuser heater ON/OFF control is performed, the zero-cross signal is not input within 3 s.	Defective PWB.	Replace the power source PWB or engine PWB and check for correct operation.
C6420	Fuser unit fuse cut problem The fuse cannot be cut, When replacing the fuser unit, the fuse cannot be cut in 3 s after the fuse cut signal is turned on.	Poor contact in the connector terminals.	Check the connection of connector YC1 on the engine PWB and the continuity across the connector terminals. Repair or replace if necessary.
		Fuser unit connector inserted incorrectly.	Reinsert the fuser unit connector if necessary.

Code	Contents	Remarks	
		Causes	Check procedures/corrective measures
C7000	Toner motor problem A motor over-current signal is detected continuously for 1 s or longer.	Poor contact in the connector terminals.	Check the connection of connector YC1 on the engine PWB and the connector on the toner feed motor, and the continuity across the connector terminals. Repair or replace if necessary.
		Broken the gear.	Check visually and replace the gear if necessary.
		Defective toner feed motor.	Run maintenance item U135 and check if the toner feed motor operates. If not, replace the toner feed motor.
		Defective engine PWB.	Replace the engine PWB and check for correct operation.
C7200	Broken inner thermistor wire An abnormal value is detected in the input data to inner thermistor.	Poor contact in the connector terminals.	Check the connection of connector YC32 on the engine PWB and the continuity across the connector terminals. Repair or replace if necessary.
		Defective temperature sensor.	Replace the temperature sensor.
C7300	Toner hopper problem Toner emptiness is detected for 300 s, three times during the toner replenishment.	Poor contact in the connector terminals.	Check the connection of connector YC1 on the engine PWB and the continuity across the connector terminals. Repair or replace if necessary.
		Defective toner sensor.	Replace the developing unit.
C7400	Developing unit connector insertion problem Absence of the developing unit is detected.	Developing unit connector inserted incorrectly.	Reinsert the developing unit connector if necessary.
		Defective developing unit connector.	Replace the developing unit.
C7410	Drum unit connector insertion problem Absence of the drum unit is detected.	Drum unit connector inserted incorrectly.	Reinsert the drum unit connector if necessary.
		Defective drum unit connector.	Replace the drum unit.
C7800	Broken external thermistor wire The thermistor output value is 4.5 V or more.	Poor contact in the connector terminals.	Check the connection of connector YC10 on the engine PWB and the continuity across the connector terminals. Repair or replace if necessary.
		Defective humidity sensor.	Replace the humidity sensor.
C7900	Drum EEPROM error Reading from or writing to EEPROM cannot be performed.	Poor contact in the connector terminals.	Check the connection of connector on the engine PWB and the continuity across the connector terminals. Repair or replace if necessary.
		Defective drum unit.	Replace the drum unit.

Code	Contents	Remarks	
		Causes	Check procedures/corrective measures
C7910	Developing unit EEPROM error Reading from or writing to EEPROM cannot be performed.	Poor contact in the connector terminals.	Check the connection of connector on the engine PWB and the continuity across the connector terminals. Repair or replace if necessary.
		Defective developing unit.	Replace the developing unit.
C8030	Tray upper limit detection problem (optional document finisher) When the tray elevation motor raises a tray, the ON status of the tray upper limit sensor is detected.	The tray upper limit sensor, paper surface sensor 1/2 connector makes poor contact.	Reinsert the connector. Also check for continuity within the connector cable. If none, remedy or replace the cable.
		Defective tray upper limit sensor, paper surface sensor 1/2.	Replace the sensor.
		Defective finisher main PWB.	Replace the finisher main PWB and check for correct operation.
C8040	Belt problem (optional document finisher) The belt sensor does not turn on/off within specified time of the belt solenoid turning on.	The belt sensor, belt solenoid connector makes poor contact.	Reinsert the connector. Also check for continuity within the connector cable. If none, remedy or replace the cable.
		Defective belt sensor.	Replace the belt sensor.
		Defective belt solenoid.	Replace the belt solenoid.
		Defective finisher main PWB.	Replace the finisher main PWB and check for correct operation.
C8140	Tray elevation motor problem (optional document finisher) The tray low limit sensor or paper surface sensor 1/2 cannot be detected to be on within 10 s since the tray elevation motor is activated.	The tray elevation motor connector makes poor contact.	Reinsert the connector. Also check for continuity within the connector cable. If none, remedy or replace the cable.
		The tray elevation motor malfunctions.	Replace the tray elevation motor.
		The tray lower limit sensor, paper surface sensor 1/2 connector makes poor contact.	Reinsert the connector. Also check for continuity within the connector cable. If none, remedy or replace the cable.
		Defective tray lower limit sensor, paper surface sensor 1/2.	Replace the sensor.
		Defective finisher main PWB.	Replace the finisher main PWB and check for correct operation.

Code	Contents	Remarks	
		Causes	Check procedures/corrective measures
C8170	Finisher front side registration motor problem (optional built-in finisher) When the front-side registration home-position sensor is turned on during initialization, the sensor did not turn on while it has moved by 106 pulses. When the front-side registration home-position sensor is turned off during initialization, the sensor did not turn on in 3 s.	The front side registration motor connector makes poor contact.	Reinsert the connector. Also check for continuity within the connector cable. If none, remedy or replace the cable.
		Defective front side registration motor.	Replace front side registration motor.
		The front side registration home position sensor connector makes poor contact.	Reinsert the connector. Also check for continuity within the connector cable. If none, remedy or replace the cable.
		Defective front side registration home position sensor.	Replace the front side registration home position sensor.
		Defective finisher control PWB.	Replace the finisher control PWB and check for correct operation.
C8180	Finisher rear side registration motor problem (optional built-in finisher) When the rear-side registration home-position sensor is turned on during initialization, the sensor did not turn on while it has moved by 106 pulses. When the rear-side registration home-position sensor is turned off during initialization, the sensor did not turn on in 3 s.	The rear side registration motor connector makes poor contact.	Reinsert the connector. Also check for continuity within the connector cable. If none, remedy or replace the cable.
		Defective rear side registration motor.	Replace rear side registration motor.
		The rear side registration home position sensor connector makes poor contact.	Reinsert the connector. Also check for continuity within the connector cable. If none, remedy or replace the cable.
		Defective rear side registration home position sensor.	Replace the rear side registration home position sensor.
		Defective finisher control PWB.	Replace the finisher control PWB and check for correct operation.
C8190	Finisher trailing edge registration motor problem (optional built-in finisher) When the trailing edge registration home-position sensor is turned on during initialization, the sensor did not turn on while it has moved by 106 pulses. When the trailing edge registration home-position sensor is turned off during initialization, the sensor did not turn on in 3 s.	The trailing edge registration motor connector makes poor contact.	Reinsert the connector. Also check for continuity within the connector cable. If none, remedy or replace the cable.
		Defective trailing edge registration motor.	Replace trailing edge registration motor.
		The trailing edge registration home position sensor connector makes poor contact.	Reinsert the connector. Also check for continuity within the connector cable. If none, remedy or replace the cable.
		Defective trailing edge registration home position sensor.	Replace the trailing edge registration home position sensor.
		Defective finisher control PWB.	Replace the finisher control PWB and check for correct operation.

Code	Contents	Remarks	
		Causes	Check procedures/corrective measures
C8210	Stapler problem (optional document finisher) Jam 82 is indicated.	The stapler connector makes poor contact.	Reinsert the connector. Also check for continuity within the connector cable. If none, remedy or replace the cable.
		The stapler is blocked with a staple.	Remove the stapler cartridge, and check the cartridge and the stapling section of the stapler.
		The stapler is broken.	Replace the stapler and check for correct operation.
		Defective finisher main PWB.	Replace the finisher main PWB and check for correct operation.
	Finisher stapler problem (optional built-in finisher) The stapler home position sensor does not change state from nondetection to detection within 200 ms of the start of stapler motor counterclockwise (forward) rotation. During initialization, the stapler home position sensor does not change state from non-detection to detection within 600 ms of the start of stapler motor clockwise (reverse) rotation.	The stapler connector makes poor contact.	Reinsert the connector. Also check for continuity within the connector cable. If none, remedy or replace the cable.
		The stapler is blocked with a staple.	Remove the stapler cartridge, and check the cartridge and the stapling section of the stapler.
		The stapler is broken.	Replace the front stapler and check for correct operation.
		Defective finisher control PWB.	Replace the finisher control PWB and check for correct operation.
C8320	Adjustment motor 2 problem (optional document finisher) The adjustment sensor 2 does not turn on/off within specified time of the adjustment motor 2 turning on.	The adjustment sensor 2, adjustment motor 2 connector makes poor contact.	Reinsert the connector. Also check for continuity within the connector cable. If none, remedy or replace the cable.
		Defective adjustment sensor 2.	Replace the adjustment sensor 2.
		Defective adjustment motor 2.	Replace the adjustment motor 2.
		Defective finisher main PWB.	Replace the finisher main PWB and check for correct operation.
C8330	Adjustment motor 1 problem (optional document finisher) The adjustment sensor 1 does not turn on/off within specified time of the adjustment motor 1 turning on.	The adjustment sensor 1, adjustment motor 1 connector makes poor contact.	Reinsert the connector. Also check for continuity within the connector cable. If none, remedy or replace the cable.
		Defective adjustment sensor 1.	Replace the adjustment sensor 1.
		Defective adjustment motor 1.	Replace the adjustment motor 1.
		Defective finisher main PWB.	Replace the finisher main PWB and check for correct operation.

Code	Contents	Remarks	
		Causes	Check procedures/corrective measures
C8350	Roller motor problem (optional document finisher) The roller sensor does not turn on/off within specified time of the roller motor turning on.	The roller sensor, roller motor connector makes poor contact.	Reinsert the connector. Also check for continuity within the connector cable. If none, remedy or replace the cable.
		Defective roller sensor.	Replace the roller sensor.
		Defective roller motor.	Replace the roller motor.
		Defective finisher main PWB.	Replace the finisher main PWB and check for correct operation.
C8360	Slide motor problem (optional document finisher) The slide sensor does not turn on/off within specified time of the slide motor turning on.	The slide sensor, slide motor connector makes poor contact.	Reinsert the connector. Also check for continuity within the connector cable. If none, remedy or replace the cable.
		Defective slide sensor.	Replace the slide sensor.
		Defective slide motor.	Replace the slide motor.
		Defective finisher main PWB.	Replace the finisher main PWB and check for correct operation.
C8440	Sensor adjusting problem (optional document finisher) The sensor cannot be adjusted within the specified range.	The paper entry sensor connector makes poor contact.	Reinsert the connector. Also check for continuity within the connector cable. If none, remedy or replace the cable.
		Defective paper entry sensor.	Replace the paper entry sensor and check for correct operation.
		The optical path of the paper entry sensor is blocked by foreign matter.	Remove the foreign matter.
		Defective finisher main PWB.	Replace the finisher main PWB and check for correct operation.
C8460	EEPROM problem (optional document finisher) Reading from or writing to EEPROM cannot be performed.	Defective EEPROM or finisher main PWB.	Replace the finisher main PWB and check for correct operation.
C8800	Document finisher communication error (optional 3000-sheet document finisher) A communication error from document finisher is detected 10 times in succession.	Poor contact in the connector terminals.	Check the connection of connector on the engine PWB and the connector on the finisher main PWB, and the continuity across the connector terminals. Repair or replace if necessary.
		Defective PWB.	Replace the finisher main PWB or engine PWB and check for correct operation.

Code	Contents	Remarks	
		Causes	Check procedures/corrective measures
C9000	Optional DP communication problem A communication error is detected.	Poor contact in the connector terminals.	Check the connection of connector YC7 and YC8 on the scanner PWB and the connector of the DP, and the continuity across the connector terminals. Repair or replace if necessary.
		Defective DP main PWB.	Replace the DP main PWB and check for correct operation.
C9060	DP EEPROM error (optional DP) Read and write data does not match. Data in the specified area of the backup memory does not match the specified values.	Defective DP main PWB.	Replace the DP main PWB and check for correct operation.
		Device damage of EEPROM.	Contact the Service Administrative Division.
C9500			Contact the Service Administrative Division.
C9510			Contact the Service Administrative Division.
C9520			Contact the Service Administrative Division.
F000	Operation panel PWB communication error	Defective main PWB.	Replace the main PWB and check for correct operation.
		Defective operation panel PWB.	Replace the operation panel PWB and check for correct operation.
F040	Engine PWB communication error	Defective main PWB.	Replace the main PWB and check for correct operation.
		Defective engine PWB.	Replace the engine PWB and check for correct operation.
F041	Scanner PWB communication error	Defective main PWB.	Replace the main PWB and check for correct operation.
		Defective scanner PWB.	Replace the scanner PWB and check for correct operation.
F050	Engine ROM checksum error	Defective engine PWB.	Replace the engine PWB and check for correct operation.
F090	Fax control PWB communication error	Defective main PWB.	Replace the main PWB and check for correct operation.
F278	Power supply in drive system error	Main power switch was turned off without using the power key, or a power failure has occurred.	Turn on power. (To switch off power, first press the power key until the main power indicator goes off, then turn the main power switch off.)

1-4-3 Image formation problems

(1) No image appears (entirely white).

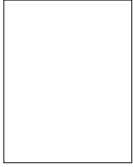

See page 1-4-35.

(2) No image appears (entirely black).



See page 1-4-35.

(3) Image is too light.



See page 1-4-36.

(4) Background is visible.



See page 1-4-36.

(5) A white line appears longitudinally.



See page 1-4-36.

(6) A black line appears longitudinally.

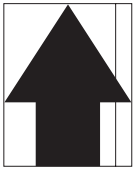

See page 1-4-37.

(7) A black line appears laterally.



See page 1-4-37.

(8) One side of the copy image is darker than the other.



See page 1-4-37.

(9) Black dots appear on the image.



See page 1-4-37.

(10) Image is blurred.



See page 1-4-38.

(11) The leading edge of the image is consistently misaligned with the original.



See page 1-4-38.

(12) The leading edge of the image is sporadically misaligned with the original.



See page 1-4-38.

(13) Paper creases.

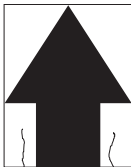

See page 1-4-38.

(14) Offset occurs.

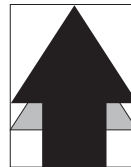

See page 1-4-39.

(15) Image is partly missing.



See page 1-4-39.

(16) Fusing is poor.

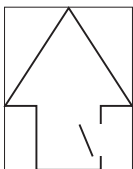

See page 1-4-39.

(17) Image is out of focus.



See page 1-4-39.

(18) Image center does not align with the original center.



See page 1-4-40.

(1) No image appears (entirely white).

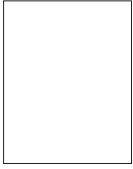
Copy example	Causes		Check procedures/corrective measures
	No transfer charging.	The connector terminals of the high voltage PWB make poor contact.	Reinsert the connector. Also check for continuity within the connector cable. If none, remedy or replace the cable.
		Defective engine PWB.	Check if YC12-11 on the engine PWB goes low when maintenance item U101 is run. If not, replace the engine PWB.
		Defective high voltage PWB.	Check if transfer charging takes place when CN1-2 on the high voltage PWB goes low while maintenance item U101 is run. If not, replace the high voltage PWB.
	No LSU laser is output.	Defective laser scanner unit.	Replace the laser scanner unit (see page 1-5-26).
		Defective main PWB.	Check if YC21-3 on the main PWB goes low when maintenance item U100 is run. If not, replace the main PWB.
	No developing bias output.	The connector terminals of the high voltage PWB make poor contact.	Reinsert the connector. Also check for continuity within the connector cable. If none, remedy or replace the cable.
		Defective engine PWB.	Check if YC12-2 on the engine PWB goes low when maintenance item U101 is run. If not, replace the engine PWB.
		Defective high voltage PWB.	Check if developing bias is output when CN1-11 on the high voltage PWB goes low while maintenance item U101 is run. If not, replace the high voltage PWB.

(2) No image appears (entirely black).

Copy example	Causes		Check procedures/corrective measures
	No main charging.	Broken main charger wire.	Replace the main charger unit (see page 1-5-33).
		Leaking main charger housing.	Clean the main charger wire and grid.
		The connector terminals of the high voltage PWB make poor contact.	Reinsert the connector. Also check for continuity within the connector cable. If none, remedy or replace the cable.
		Defective engine PWB.	Check if YC12-5 on the engine PWB goes low when maintenance item U100 is run. If not, replace the engine PWB.
		Defective high voltage PWB.	Check if main charging takes place when CN1-8 on the high voltage PWB goes low while maintenance item U100 is run. If not, replace the high voltage PWB.
	Exposure lamp fails to light.	Poor contact in the exposure lamp connector terminals.	Reinsert the connector. Also check for continuity within the connector cable. If none, remedy or replace the cable.
		Defective inverter PWB.	Check if the exposure lamp lights when CN1-1 and CN1-6 on the inverter PWB goes low while maintenance item U061 is run. If not, replace the inverter PWB.
		Defective scanner PWB.	Check if YC5-1 and YC5-6 on the scanner PWB goes low when maintenance item U061 is run. If not, replace the scanner PWB.

(3) Image is too light.

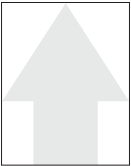
Copy example	Causes	Check procedures/corrective measures	
	Insufficient toner.	If the display shows the message requesting toner replenishment, replace the container.	
	Deteriorated toner.	Perform the drum refresh operation.	
	Defective transfer charging output.	The connector terminals of the high voltage PWB make poor contact.	Reinsert the connector. Also check for continuity within the connector cable. If none, remedy or replace the cable.
		Defective engine PWB.	Check if YC12-11 on the engine PWB goes low when maintenance item U101 is run. If not, replace the engine PWB.
Defective high voltage PWB.	Check if transfer charging takes place when CN1-2 on the high voltage PWB goes low while maintenance item U101 is run. If not, replace the high voltage PWB.		

(4) Background is visible.

Copy example	Causes	Check procedures/corrective measures
	Deteriorated toner.	Perform the drum refresh operation.
	Dirty main charger wire.	Clean the wire or, if it is extremely dirty, replace it (see page 1-5-33).

(5) A white line appears longitudinally.

Copy example	Causes	Check procedures/corrective measures
	Foreign matter in the developing unit.	Check if the magnetic brush is formed uniformly. Replace the developing unit if any foreign matter (see page 1-5-35).
	Dirty shading plate.	Clean the shading plate.

(6) A black line appears longitudinally.

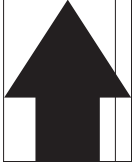
Copy example	Causes	Check procedures/corrective measures
	Dirty platen.	Clean the platen.
	Dirty or flawed drum.	Perform the drum refresh operation. If the drum is flawed, replace the drum unit (see page 1-5-31).
	Deformed or worn cleaning blade.	Replace the drum unit (see page 1-5-31).
	Dirty scanner mirror.	Clean the scanner mirror.
	Dirty main charger wire.	Clean the wire or, if it is extremely dirty, replace it (see page 1-5-33).

(7) A black line appears laterally.

Copy example	Causes	Check procedures/corrective measures
	Flawed drum.	Replace the drum unit (see page 1-5-31).
	Dirty developing section.	Clean any part contaminated with toner in the developing section.
	Leaking main charger housing.	Clean the main charger wire and grid.
	Leaking separation electrode.	Clean the separation electrode.

(8) One side of the copy image is darker than the other.

Copy example	Causes	Check procedures/corrective measures
	Dirty main charger wire.	Clean the wire or, if it is extremely dirty, replace it (see page 1-5-33).
	Defective exposure lamp.	Check if the exposure lamp light is distributed evenly. If not, replace the exposure lamp (see page 1-5-15).

(9) Black dots appear on the image.

Copy example	Causes	Check procedures/corrective measures
	Dirty or flawed drum.	Perform the drum refresh operation. If the drum is flawed, replace the drum unit (see page 1-5-31).
	Dirty platen.	Clean the platen.
	Deformed or worn cleaning blade.	Replace the drum unit (see page 1-5-31).
	Dirty drum separation claws.	Clean the drum separation claws.
	Dirty the heat roller separation claws.	Clean the heat roller separation claws.

(10) Image is blurred.

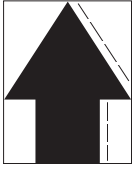
Copy example	Causes	Check procedures/corrective measures
	Scanner moves erratically.	Check if there is any foreign matter on the front and rear scanner rails. If any, remove it.
	Deformed press roller.	Replace the press roller (see page 1-5-41).
	Paper conveying section drive problem.	Check the gears and belts and, if necessary, grease them.

(11) The leading edge of the image is consistently misaligned with the original.

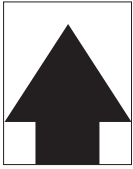
Copy example	Causes	Check procedures/corrective measures
	Misadjusted leading edge registration.	Run maintenance mode U034 to readjust the leading edge registration (see page 1-3-22).
	Misadjusted scanner leading edge registration.	Run maintenance mode U066 to readjust the scanner leading edge registration (see page 1-3-30).

(12) The leading edge of the image is sporadically misaligned with the original.

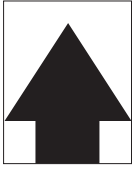
Copy example	Causes	Check procedures/corrective measures
	Feed clutch, paper feed clutch, MP paper feed clutch or registration clutch installed or operating incorrectly.	Check the installation position and operation of each clutch. If any of them operates incorrectly, replace it.

(13) Paper creases.

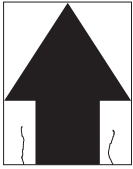
Copy example	Causes	Check procedures/corrective measures
	Paper curled.	Check the paper storage conditions.
	Paper damp.	Check the paper storage conditions.
	Defective pressure springs.	Replace the pressure springs.
	Defective separation.	Check the drum separation claws and heat roller separation claws.

(14) Offset occurs.

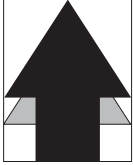
Copy example	Causes	Check procedures/corrective measures
	Defective cleaning blade.	Replace the drum unit (see page 1-5-31).
	Defective fuser unit.	Check the heat roller and press roller.
	Wrong types of paper.	Check if the paper meets specifications. Replace paper.

(15) Image is partly missing.

Copy example	Causes	Check procedures/corrective measures
	Paper damp.	Check the paper storage conditions.
	Paper creased.	Change the paper.
	Drum condensation.	Perform the drum refresh operation.
	Dirty or flawed drum.	Perform the drum refresh operation. If the drum is flawed, replace the drum unit (see page 1-5-31).

(16) Fusing is poor.

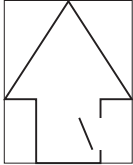
Copy example	Causes	Check procedures/corrective measures
	Wrong types of paper.	Check if the paper meets specifications. Replace paper.
	Defective pressure springs.	Replace the pressure springs.
	Flawed press roller.	Replace the press roller (see page 1-5-41).
	Flawed fuser heater.	Replace the fuser heaters (see page 1-5-43).

(17) Image is out of focus.

Copy example	Causes	Check procedures/corrective measures
	Defective image scanning unit.	Replace the image scanning unit (see page 1-5-24).
	Drum condensation.	Perform the drum refresh operation.

(18) Image center does not align with the original center.

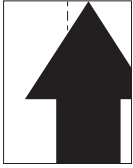
Copy example	Causes	Check procedures/corrective measures
	Misadjusted image center line.	Run maintenance item U034 to readjust the center line of image printing (see page 1-3-23).
	Misadjusted scanner center line.	Run maintenance item U067 to readjust the scanner leading edge registration (see page 1-3-31).
	Original is not placed correctly.	Place the original correctly.

1-4-4 Electric problems

Troubleshooting to each failure must be in the order of the numbered symptoms.

Problem	Causes	Check procedures/corrective measures
(1) The machine does not operate when the main power switch is turned on.	1. The power cord is not plugged in properly.	Check the contact between the power plug and the outlet.
	2. No electricity at the power outlet.	Measure the input voltage.
	3. Broken power cord.	Check for continuity. If none, replace the cord.
	4. Defective main power switch.	Check for continuity across the contacts. If none, replace the main power switch.
	5. Defective power source PWB.	With AC present, check for 24 V DC at YC8-4 on the power source PWB and 5 V DC at YC8-1. If none, replace the power source PWB.
(2) The eject motor does not operate.	1. Poor contact in the connector terminals.	Reinsert the connector. Also check for continuity within the connector cable. If none, remedy or replace the cable.
	2. Defective drive transmission system.	Check if the rollers and gears rotate smoothly. If not, grease the bushings and gears. Check for broken gears and replace if any.
	3. Defective eject motor.	Run maintenance item U030 and check if the eject motor operates. If not, replace the eject motor.
	4. Defective engine PWB.	Run maintenance item U030 and check if the eject motor operates. If not, replace the engine PWB.
(3) The toner feed motor does not operate.	1. Poor contact in the connector terminals.	Reinsert the connector. Also check for continuity within the connector cable. If none, remedy or replace the cable.
	2. Defective drive transmission system.	Check if the rollers and gears rotate smoothly. If not, grease the bushings and gears. Check for broken gears and replace if any.
	3. Defective toner feed motor.	Run maintenance item U135 and check if the toner feed motor operates. If not, replace the toner feed motor.
	4. Defective engine PWB.	Run maintenance item U135 and check if the toner feed motor operates. If not, replace the engine PWB.
(4) The power source fan motor does not operate.	1. Poor contact in the connector terminals.	Reinsert the connector. Also check for continuity within the connector cable. If none, remedy or replace the cable.
	2. Broken motor coil.	Check for continuity across the coil. If none, replace the motor.
	3. Defective motor.	Run maintenance item U037 and check if the motor operates when the following terminals on the PWB goes low. If not, replace the corresponding motor. Power source fan motor: YC6-1 on the power source PWB
	4. Defective power source PWB.	Run maintenance item U037 and check if following terminals on the PWB goes low. If not, replace the power source PWB. Power source fan motor: YC6-1 on the power source PWB

Problem	Causes	Check procedures/corrective measures
(5) The developing fan motor, fuser fan motor, eject fan motor or paper conveying fan motor 1/2 does not operate.	1. Poor contact in the connector terminals.	Reinsert the connector. Also check for continuity within the connector cable. If none, remedy or replace the cable.
	2. Broken motor coil.	Check for continuity across the coil. If none, replace the motor.
	3. Defective motor.	Run maintenance item U037 and check if the motor operates when the following terminals on the PWB goes low. If not, replace the corresponding motor. Developing fan motor: YC2-6 on the engine PWB Fuser fan motor: YC13-2 on the engine PWB Eject fan motor: YC37-2 on the engine PWB Paper conveying fan motor 1: YC8-B16 on the engine PWB Paper conveying fan motor 2: YC8-B18 on the engine PWB
	4. Defective engine PWB.	Run maintenance item U037 and check if following terminals on the PWB goes low. If not, replace the engine PWB. Developing fan motor: YC2-6 on the engine PWB Fuser fan motor: YC13-2 on the engine PWB Eject fan motor: YC37-2 on the engine PWB Paper conveying fan motor 1: YC8-B16 on the engine PWB Paper conveying fan motor 2: YC8-B18 on the engine PWB
(6) The controller fan motor or operation fan motor does not operate.	1. Poor contact in the connector terminals.	Reinsert the connector. Also check for continuity within the connector cable. If none, remedy or replace the cable.
	2. Broken motor coil.	Check for continuity across the coil. If none, replace the motor.
(7) The paper feed clutch 1/2, feed clutch 1/2/3, MP paper feed clutch, MP feed clutch, registration clutch, duplex feed clutch or toner feed clutch does not operate.	1. Broken clutch coil.	Check for continuity across the coil. If none, replace the clutch.
	2. Poor contact in the connector terminals.	Reinsert the connector. Also check for continuity within the connector cable. If none, remedy or replace the cable.
	3. Defective engine PWB.	Run maintenance item U032 and check if following terminals on the engine PWB goes low. If not, replace the engine PWB. Paper feed clutch 1: YC8-A13 on the engine PWB Paper feed clutch 2: YC8-A15 on the engine PWB Feed clutch 1: YC8-B8 on the engine PWB Feed clutch 2: YC8-A12 on the engine PWB Feed clutch 3: YC8-A5 on the engine PWB MP paper feed clutch: YC7-9 on the engine PWB MP feed clutch: YC7-11 on the engine PWB Registration clutch: YC8-B15 on the engine PWB Duplex feed clutch: YC8-B9 on the engine PWB Toner feed clutch: YC8-A17 on the engine PWB
(8) The feedshift solenoid does not operate.	1. Broken solenoid coil.	Check for continuity across the coil. If none, replace the solenoid.
	2. Poor contact in the connector terminals.	Reinsert the connector. Also check for continuity within the connector cable. If none, remedy or replace the cable.
	3. Defective engine PWB.	Run maintenance item U033 and check if the solenoid operates. If not, replace the engine PWB.

Problem	Causes	Check procedures/corrective measures
(9) The exposure lamp does not turn on or off.	1. Poor contact in the connector terminals.	Reinsert the connector. Also check for continuity within the connector cable. If none, remedy or replace the cable.
	2. Defective scanner PWB.	Run maintenance item U061 and check if YC5-1 and YC5-6 on the scanner PWB goes low. If not, replace the scanner PWB. If YC16-1 and YC16-6 on the scanner PWB is always low, replace the scanner PWB.
	3. Defective inverter PWB.	Run maintenance item U061 and check if the exposure lamp turns on with CN1-1 and CN1-6 on the inverter PWB go low. If not, replace the inverter PWB. If the exposure lamp does not turn off with CN1-1 and CN1-6 on the inverter PWB high, replace the inverter PWB.
	4. Defective exposure lamp.	Replace the exposure lamp even if checking or correcting other measures.
(10) Main charging is not performed.	1. Broken main charger wire.	Replace the main charger unit (see page 1-5-33).
	2. Leaking main charger housing.	Clean the main charger wire and grid.
	3. The connector terminals of the high voltage PWB make poor contact.	Reinsert the connector. Also check for continuity within the connector cable. If none, remedy or replace the cable.
	4. Defective engine PWB.	Check if YC12-5 on the engine PWB goes low when maintenance item U100 is run. If not, replace the engine PWB.
	5. Defective high voltage PWB.	Check if main charging takes place when CN1-8 on the high voltage PWB goes low while maintenance item U100 is run. If not, replace the high voltage PWB.
(11) No developing bias is output.	1. The connector terminals of the high voltage PWB make poor contact.	Reinsert the connector. Also check for continuity within the connector cable. If none, remedy or replace the cable.
	2. Defective engine PWB.	Check if YC12-2 on the engine PWB goes low when maintenance item U101 is run. If not, replace the engine PWB.
	3. Defective high voltage PWB.	Check if developing bias is output when CN1-11 on the high voltage PWB goes low while maintenance item U101 is run. If not, replace the high voltage PWB.
(12) Transfer charging is not performed.	1. The connector terminals of the high voltage PWB make poor contact.	Reinsert the connector. Also check for continuity within the connector cable. If none, remedy or replace the cable.
	2. Defective engine PWB.	Check if YC12-11 on the engine PWB goes low when maintenance item U101 is run. If not, replace the engine PWB.
	3. Defective high voltage PWB.	Check if transfer charging takes place when CN1-2 on the high voltage PWB goes low while maintenance item U101 is run. If not, replace the high voltage PWB.

Problem	Causes	Check procedures/corrective measures
(13) The original size is not detected correctly.	1. Original is not placed correctly.	Check the original and correct if necessary.
	2. Poor contact in the original detection switch or original size sensor connector terminals.	Reinsert the connector. Also check for continuity within the connector cable. If none, remedy or replace the cable.
	3. Defective original detection switch.	If the level of YC17-5 on the engine PWB does not go low when the original detection switch is turned on and off, replace the original detection switch.
	4. Defective original size sensor.	Check if sensor operates correctly. If not, replace it.
(14) The touch panel keys do not work.	1. Poor contact in the touch panel connector terminals.	Reinsert the connector. Also check for continuity within the connector cable. If none, remedy or replace the cable.
	2. Defective touch panel or main operation PWB.	If any keys do not work after running the maintenance item U201 to initialize the touch panel, replace the touch panel or main operation unit PWB.
(15) The message requesting paper to be loaded is shown when paper is present on the cassette 1/2 or MP tray.	1. Poor contact in the connector terminals of paper switch 1/2 or MP paper switch.	Reinsert the connector. Also check for continuity within the connector cable. If none, remedy or replace the cable.
	2. Defective paper switch 1/2 or MP paper switch.	If the level of following terminal on PWB does not go low when the switch is turned on and off, replace the switch. Paper switch 1: YC23-B12 on the engine PWB Paper switch 2: YC23-A5 on the engine PWB MP paper switch: YC7-6 on the engine PWB
(16) The size of paper on the cassette 1/2 or MP tray is not displayed correctly.	1. Poor contact in the connector terminals of paper size length switch 1/2, paper size width switch 1/2, MP paper size length switch or MP paper size width switch.	Reinsert the connector. Also check for continuity within the connector cable. If none, remedy or replace the cable.
	2. Defective paper size length switch 1/2 or MP paper size length switch.	If the level of following terminal on PWB does not go low when the switch is turned on and off, replace the switch. Paper size length switch 1: YC23-B2 on the engine PWB Paper size length switch 2: YC23-A12 on the engine PWB MP paper size length switch: YC7-13 on the engine PWB
	3. Defective paper size width switch 1/2 or MP paper size width switch.	If the level of following terminal on PWB does not change when the width guide in the cassette 1/2 or insert guide on the MP tray is moved, replace the switch. Paper size width switch 1: YC22-5, 7, 11 on the engine PWB Paper size width switch 2: YC22-6, 8, 12 on the engine PWB MP paper size width switch: YC7-1, 2, 3 on the engine PWB

Problem	Causes	Check procedures/corrective measures
(17) A paper jam in the paper feed, paper conveying, fuser, eject or duplex section is indicated when the main power switch is turned on.	1. A piece of paper torn from copy paper is caught around feed switch 1/2/3, registration switch, feedshift switch, eject switch or duplex paper conveying switch.	Check visually and remove it, if any.
	2. Defective feed switch 1/2/3, registration switch, feedshift switch, eject switch or duplex paper conveying switch.	Run maintenance item U031 and turn each switch on and off manually. Replace the switch if indication of the corresponding switch on the touch panel is not displayed in reverse.
(18) The message requesting cover to be closed is displayed when the front cover or left cover 1/2 is closed.	1. Poor contact in the connector terminals of safety switch 1/2 or left cover 2 switch.	Reinsert the connector. Also check for continuity within the connector cable. If none, remedy or replace the cable.
	2. Defective safety switch 1/2 or left cover 2 switch.	Check for continuity across each switch. If there is no continuity when the switch is on, replace it.
(19) Others.	1. Wiring is broken, shorted or makes poor contact.	Check for continuity. If none, repair.

1-4-5 Mechanical problems

Problem	Causes/check procedures	Corrective measures
(1) No primary paper feed.	Check if the surfaces of the following rollers or pulleys are dirty with paper powder: forwarding pulleys, paper feed pulleys, separation pulleys, feed rollers, registration rollers, MP forwarding pulley, MP paper feed pulley and MP separation pulley.	Clean with isopropyl alcohol.
	Check if the upper/lower forwarding pulleys, paper feed pulleys or upper/lower separation pulleys is deformed.	Replace the pulley if it is deformed (see page 1-5-3).
	Check if the MP forwarding pulley, MP paper feed pulley or MP separation pulley is deformed.	Replace the pulley if it is deformed (see page 1-5-6).
	Electrical problem with the following clutches: paper feed clutches 1/2, feed clutches 1/2/3, MP paper feed clutch and MP feed clutch.	See page 1-4-42.
(2) No secondary paper feed.	Check if the surfaces of the right and left registration rollers are dirty with paper powder.	Clean with isopropyl alcohol.
	Electrical problem with the registration clutch.	See page 1-4-42.
(3) Skewed paper feed.	Width guide in a cassette installed incorrectly.	Check the width guide visually and correct or replace if necessary.
	Deformed width guide in a cassette.	Check visually and replace any deformed guide.
	Check if a pressure spring along the paper conveying path is deformed or out of place.	Repair or replace.
(4) The scanner does not travel.	Check if the scanner wire is loose.	Reinstall the scanner wire (see page 1-5-19).
	The scanner motor malfunctions.	See page 1-4-42.
(5) Multiple sheets of paper are fed at one time.	Paper is extremely curled.	Change the paper.
	Check if the separation pulley is worn.	Replace the separation pulley if it is worn (see page 1-5-3).
	Check if the MP separation pulley is worn.	Replace the MP separation pulley if it is worn (see page 1-5-6).

Problem	Causes/check procedures	Corrective measures
(6) Paper jams.	Paper is extremely curled.	Change the paper.
	Deformed guides along the paper conveying path.	Check visually and replace any deformed guides.
	Check if the contact between the right and left registration rollers is correct.	Check visually and remedy if necessary.
	Check if the contact between the feed roller and feed pulley is correct.	Check visually and remedy if necessary.
	Check if the press roller is extremely dirty or deformed.	Clean or replace the press roller.
	Check if the contact between the heat roller and its separation claws is correct.	Repair if any springs are off the separation claws.
	Check if the contact between the eject roller and pulley is correct.	Check visually and remedy if necessary.
	The feedshift solenoid malfunctions.	See page 1-4-42.
	Check if the duplex feed pulley, upper duplex feed roller or lower duplex feed roller is deformed.	Check visually and replace the pulley or roller if deformed.
(7) Toner drops on the paper conveying path.	Check if the developing unit is extremely dirty.	Clean the developing unit.
(8) Abnormal noise is heard.	Check if the pulleys, rollers and gears operate smoothly.	Grease the bearings and gears.
	Check if the following clutches are installed correctly: paper feed clutches 1/2, feed clutches 1/2/3, MP paper feed clutch and MP feed clutch.	Correct.

1-4-6 Send error code

(1) Scan to SMB error codes

Code	Display	Remarks	
		Causes	Check procedures/corrective measures
1102	Error: User/Password or Shared Name/Folder Name	Domain name is not entered.	Enter the user name with the form of either [Domain¥User], [Domain/User] or [Domain@User].
		Assign disable user/password.	Enter the correct user name/password.
		Assign the user who is not allowed to access to folder.	Enter correct user name/password. Check the access limit of destination folder.
		Assign disable shared name.	Enter the correct shared name. Check if the prohibited letters below are used to shared name. @ () ! & # \$ % ^ ~ []`
		Host name error.	Check if the prohibited letters are used to shared name. " & ' () ; < >
1103	Error: Pathname or File Name	Domain name is not enter	Enter the user name with the form of either [Domain¥User], [Domain/User] or [Domain@User].
		Connect to the folder which is not permitted for reference/writing.	Enter correct user name/password. Check the access limit of destination folder.
		Assign disable folder path.	Enter correct folder path.
1105	Error: Not support protocol	SMB Protocol is set to OFF.	Check ON in the [Scanner]-[SMB] screen in COMMAND CENTER.
2101	Error: Can not connect	Enter the disable host name/IP address.	Enter the correct host name or IP address.
		Assign the wrong port number.	Enter the correct port number.
		Network is not connected.	Check if the server is operating properly. Check the network connection (cable. network condition within LAN, etc.).
2103	Error: Response wait with timeout	The server is unable to communicate.	Check if the server is operating properly.
2201	Error: Network transfer	Error occurs on the network.	Check the network connection (cable. network condition within LAN, etc.).
2203	Error: Response wait with timeout	Response is not returned from the server above specified time.	Check the network connection (cable. network condition within LAN, etc.).
9181	Error: Page max count over	The number of pages of a send file exceeded 999 pages.	Set the number of pages as 999 or less.

(2) Scan to FTP error codes

Code	Display	Remarks	
		Causes	Check procedures/corrective measures
1101	Error: Host name	Enter the disable host name/ IP address.	Enter the correct host name or IP address.
1102	Error: User/Password	Domain name is not entered.	Enter the user name with the form of either [Domain¥User] or [Domain/User].
		Assign disable user/pass- word.	Enter the correct user name/password.
1103	Error: Pathname or File Name	Connect to the folder which is not permitted for reference/ writing.	Enter correct user name/password. Check the access limit of destination folder.
		Assign disable folder path.	Enter correct folder path.
1105	Error: Not support protocol	FTP Protocol is set to OFF.	Check ON in the [Scanner]-[FTP] screen in COMMAND CENTER.
2101	Error: Can not connect	Enter the disable host name/ IP address.	Enter the correct host name or IP address.
		Assign the wrong port num- ber.	Enter the correct port number.
		Network is not connected.	Check if the server is operating properly. Check the network connection (cable. net- work condition within LAN, etc.).
2102	Error: Can not connect with timeout	The server is unable to com- municate.	Check if the server is operating properly.
		Send the server which does not support FTP server.	Enter the correct host name or IP address.
2103	Error: Response wait with timeout	The server is unable to com- municate.	Check if the server is operating properly.
2201	Error: Network transfer	Error occurs on the network.	Check the network connection (cable. net- work condition within LAN, etc.).
2202	Error: Network transfer with timeout	Error occurs on the network.	Check the network connection (cable. net- work condition within LAN, etc.).
2203	Error: Response wait with timeout	Response is not returned from the server above speci- fied time.	Check the network connection (cable. net- work condition within LAN, etc.).
3101	Error: Server response	The server is error status.	Check if the server is working properly.
9181	Error: Page max count over	The number of pages of a send file exceeded 999 pages.	Set the number of pages as 999 or less.

(3) Scan to E-mail error codes

Code	Display	Remarks	
		Causes	Check procedures/corrective measures
1101	Error: Host name	SMTP sever name is not set. Error SMTP server name.	Register [SMTP Server Name] in [Advanced]-[SMTP] -[General] in COMMAND CENTER.
1102	Error: User/Password	User ID for the authentication is not entered or entered wrongly. Wrong authentication password is entered.	Enter the correct user ID/password for authentication at [Advance] in COMMAND CENTER. Enter the password of [Login User Name] of the [POP3] page or the [SMTP] page correctly.
1104	Error: No Recipient address	The destination address is not specified.	Specify the destination address.
1105	Error: Not support protocol	SMTP Protocol is set to OFF.	Check ON [SMTP] in [Advanced]-[SMTP] -[General] in COMMAND CENTER.
1106	Error: No Sender Info	Sender address is not enter	Enter the correct [Sender Address] in [Advanced]-[SMTP] -[General] in COMMAND CENTER.
2101	Error: Can not connect	Select [Other authenticate] when authenticating POP before SMTP.	Select valid POP3 user other than [Other].
		The specified server is not SMTP server.	Enter the correct [SMTP Server Name] in [Advanced]-[SMTP] -[General] in COMMAND CENTER.
		Network is not connected.	Check if the server is operating properly. Check the network connection (cable. network condition within LAN, etc.).
2102	Error: Can not connect with timeout	The server is unable to communicate.	Check if the server is operating properly.
2103	Error: Response wait with timeout	The server is unable to communicate.	Check if the server is operating properly.
2201	Error: Network transfer	Error occurs on the network.	Check the network connection (cable. network condition within LAN, etc.).
2202	Error: Network transfer with timeout	Error occurs on the network.	Check the network connection (cable. network condition within LAN, etc.).
2203	Error: Response wait with timeout	Response is not returned from the server above specified time.	Check the network connection (cable. network condition within LAN, etc.).
2204	Error: E-Mail Size limit	The size of E-mail exceeds its limit.	Change the [E-mail Size Limit] in [Advanced]-[SMTP] -[General]-[E-mail Setting] in COMMAND CENTER.
3101	Error: Server response	The server is error status.	Check if the server is working properly.
		Server setting is not authenticated normally.	Check the settings for client/server authentication.
3201	Error: Not Found Authentication Mechanism	Unsupported SMTP Authentication Mechanism is found.	Check the settings for client/server Authentication Mechanism.
9181	Error: Page max count over	The number of pages of a send file exceeded 999 pages.	Set the number of pages as 999 or less.

(4) Network Twain error codes

Code	Display	Remarks	
		Causes	Check procedures/corrective measures
2202	Error: Network transfer with timeout	Response is not returned from the server above specified time.	Check the network connection (cable, network condition within LAN, etc.).
9181	Error: Page max count over	The number of pages of a send file exceeded 999 pages.	Set the number of pages as 999 or less.

(5) Software trouble error codes

Code	Display	Remarks	
		Causes	Check procedures/corrective measures
5101	Error: Not yet connected	Operation handle error. Error for stored status in the operation handle.	Turn the main power switch off and on.
5102	Error: Already connected	Operation handle error. Error for stored status in the operation handle.	Turn the main power switch off and on.
5103	Error: Not yet opened	Error for stored status in the operation handle.	Turn the main power switch off and on.
5104	Error: Already opened	Error for stored status in the operation handle.	Turn the main power switch off and on.
7101	Error: Memory Allocation	Insufficient memory space.	Turn the main power switch off and on.
7102	Error: Socket Create	Unable to create a communication socket.	Turn the main power switch off and on.
720f	Error: Unknown error	Unable to determine the cause.	Turn the main power switch off and on.

This page is intentionally left blank.

1-5-1 Precautions for assembly and disassembly

(1) Precautions

Before starting disassembly, press the power key on the operation panel to off. Make sure that the main power indicator and the Memory indicator are off before turning off the main power switch. And then unplug the power cable from the wall outlet.

Turning off the main power switch before pressing the power key to off may cause damage to the equipped hard disk.

When fax kit is installed, be sure to disconnect the modular code before starting disassembly.

When handling PWBs (printed wiring boards), do not touch parts with bare hands.

The PWBs are susceptible to static charge. Do not touch any PWB containing ICs with bare hands or any object prone to static charge.

Use only the specified parts to replace the fuser thermostat. Never substitute electric wires, as the machine may be seriously damaged.

When replacing battery on a PWB, dispose properly according to laws and regulations.

When removing the hook of the connector, be sure to release the hook.

Take care not to get the wire caught.

To reassemble the parts, use the original screws. If the types and the sizes of screws are not known, refer to the PARTS LIST.

(2) Drum

Note the following when handling or storing the drum.

When removing the drum unit, never expose the drum surface to strong direct light.

Keep the drum at an ambient temperature between 0°C/32°F and 35°C/95°F and at a relative humidity not higher than 85% RH. Avoid abrupt changes in temperature and humidity.

Avoid exposure to any substance which is harmful to or may affect the quality of the drum.

Do not touch the drum surface with any object. Should it be touched by hands or stained with oil, clean it.

(3) Toner

Store the toner container in a cool, dark place.

Avoid direct light and high humidity.

(4) How to tell a genuine Kyocera Mita toner container

As a means of brand protection, the Kyocera Mita toner container utilizes an optical security technology to enable visual validation. A validation viewer is required to accomplish this.

Hold the validation viewer over the left side part of the brand protection seal on the toner container. Through each window of the validation viewer, the left side part of the seal should be seen as follows:

A black-colored band when seen through the left side window (●)

A shiny or gold-colored band when seen through the right side window (☼)

The above will reveal that the toner container is a genuine Kyocera Mita branded toner container, otherwise, it is a counterfeit.

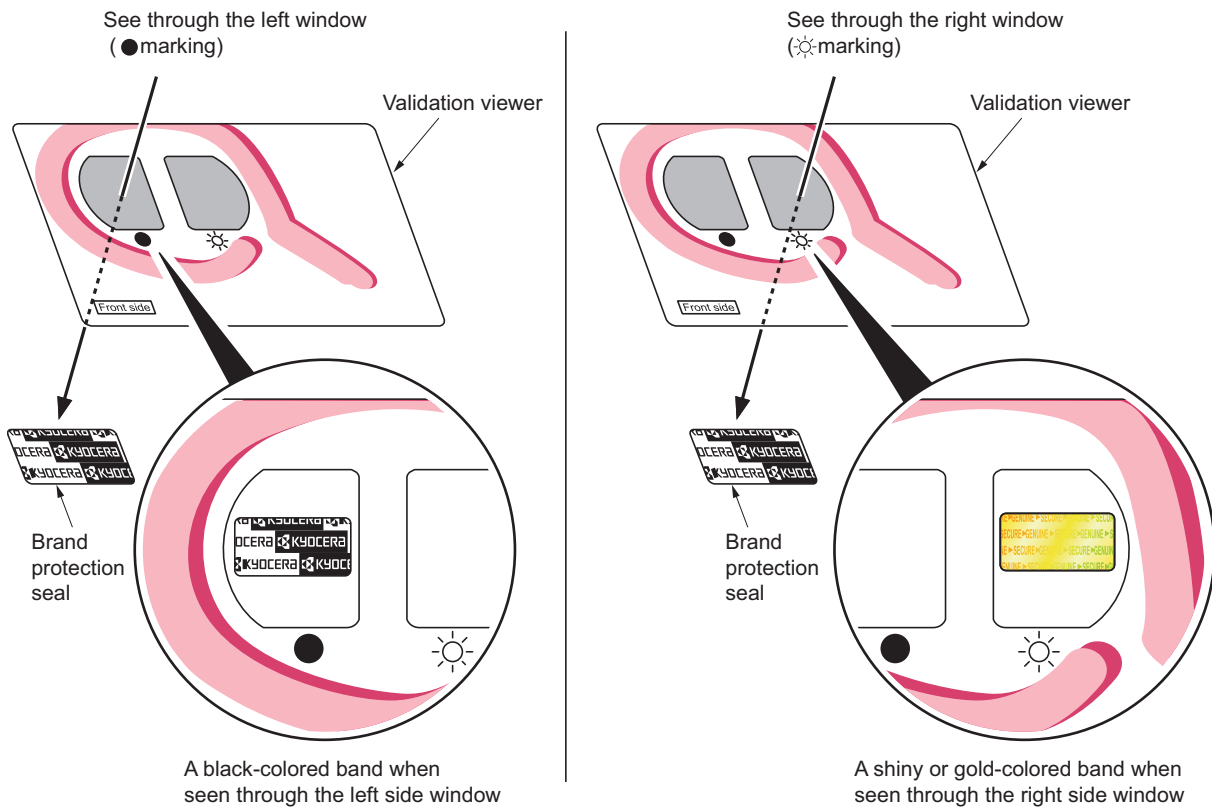

Figure 1-5-1

The brand protection seal has an incision as shown below to prohibit reuse.

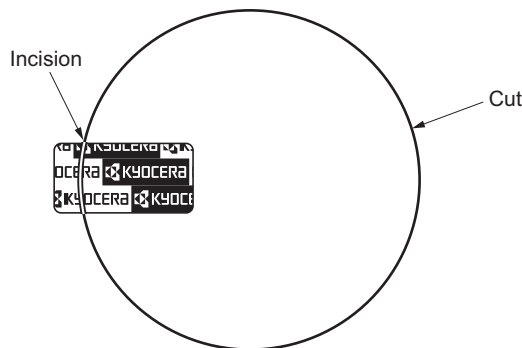

Figure 1-5-2

1-5-2 Paper feed section

(1) Detaching and refitting the forwarding, paper feed and separation pulleys

Follow the procedure below to replace the forwarding, paper feed and separation pulleys.

Procedure

Removing the primary paper feed units

1. Open the front cover and pull out the cassettes 1 and 2.
2. Remove the screw and remove the primary paper feed unit.

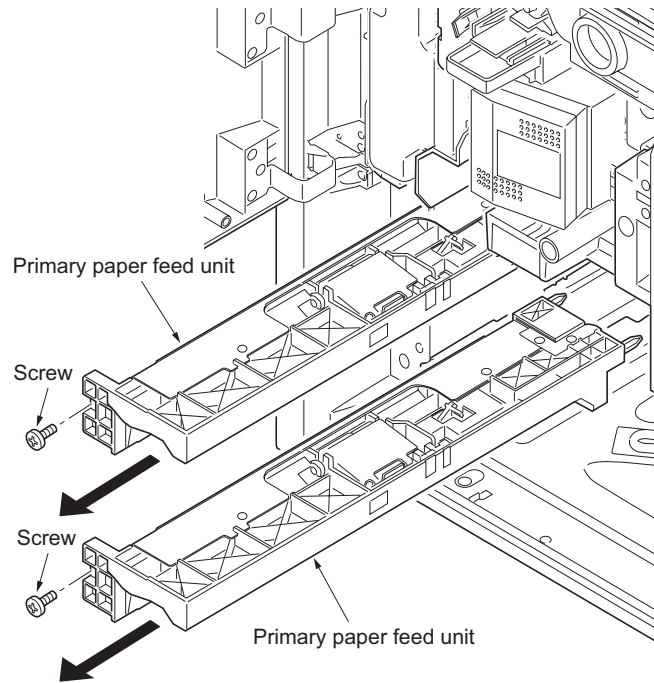

Figure 1-5-3

Removing the forwarding pulley

3. Remove the stopper from the primary paper feed unit.
4. Raise the forwarding pulley retainer in the direction of the arrow, and remove the retainer from the primary paper feed unit.

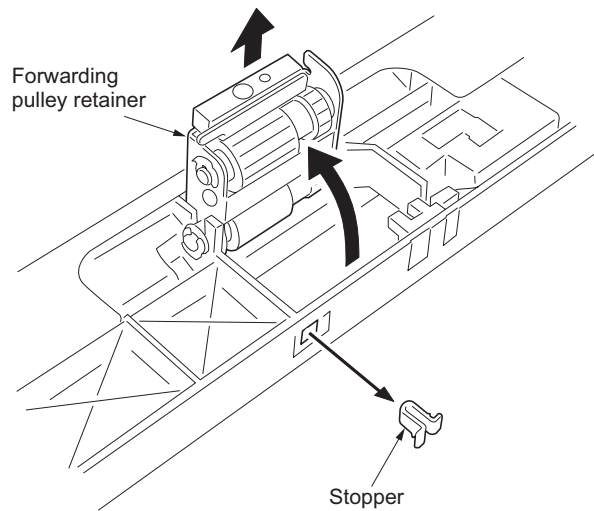

Figure 1-5-4

5. Remove the stop ring from the forwarding pulley retainer.
6. Pull the paper forwarding pulley shaft and remove the forwarding pulley.

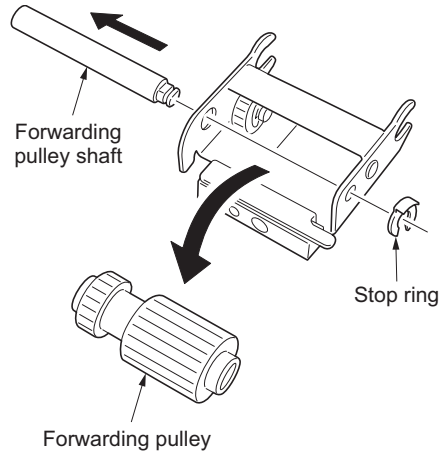

Figure 1-5-5

Removing the paper feed pulley

7. Remove two stop rings from the primary paper feed unit.
8. Pull the paper feed pulley shaft in the direction of the arrow and remove the paper feed pulley.

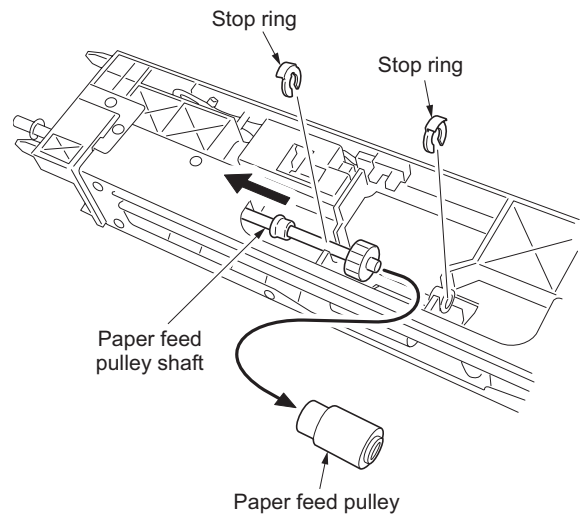

Figure 1-5-6

Removing the separation pulley

9. Remove the stop ring from the primary paper feed unit.
10. Pull the separation pulley shaft in the direction of the arrow and remove the separation pulley.

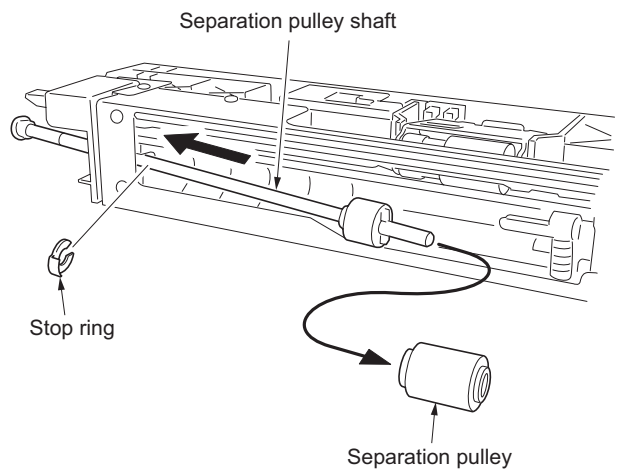

Figure 1-5-7

11. Replace the forwarding, paper feed and separation pulleys.
12. Refit all the removed parts.
When refitting the forwarding pulley, orient it correctly as shown in Figure 1-5-6.
13. When the forwarding pulley, paper feed pulley, separation pulley or the primary paper feed unit is replaced, perform maintenance mode U901 to clear the counter value (see page 1-3-84).

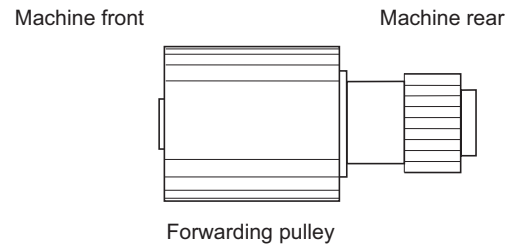

Figure 1-5-8

(2) Detaching and refitting the MP separation, MP paper feed and MP forwarding pulleys

Follow the procedure below to replace the MP separation, MP paper feed and MP forwarding pulleys.

Procedure

Removing the MP unit

1. Remove two screws and remove the scanner right cover.

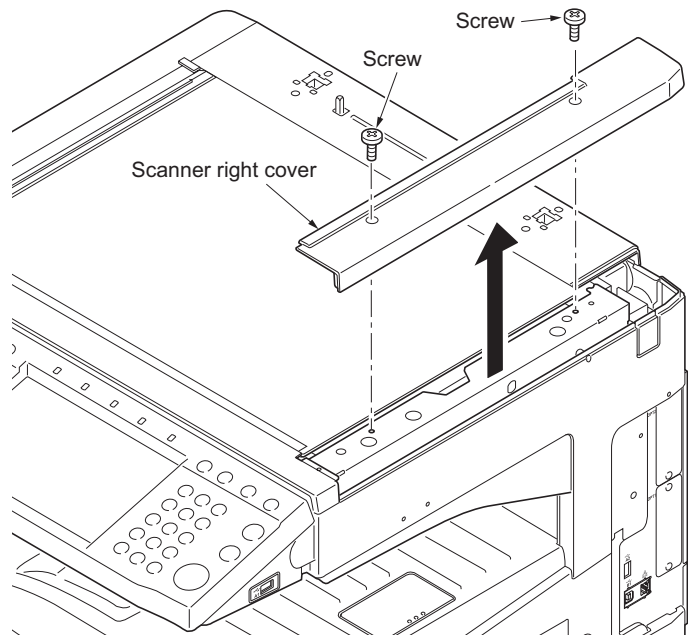

Figure 1-5-9

2. Remove four hooks and remove the right upper cover.

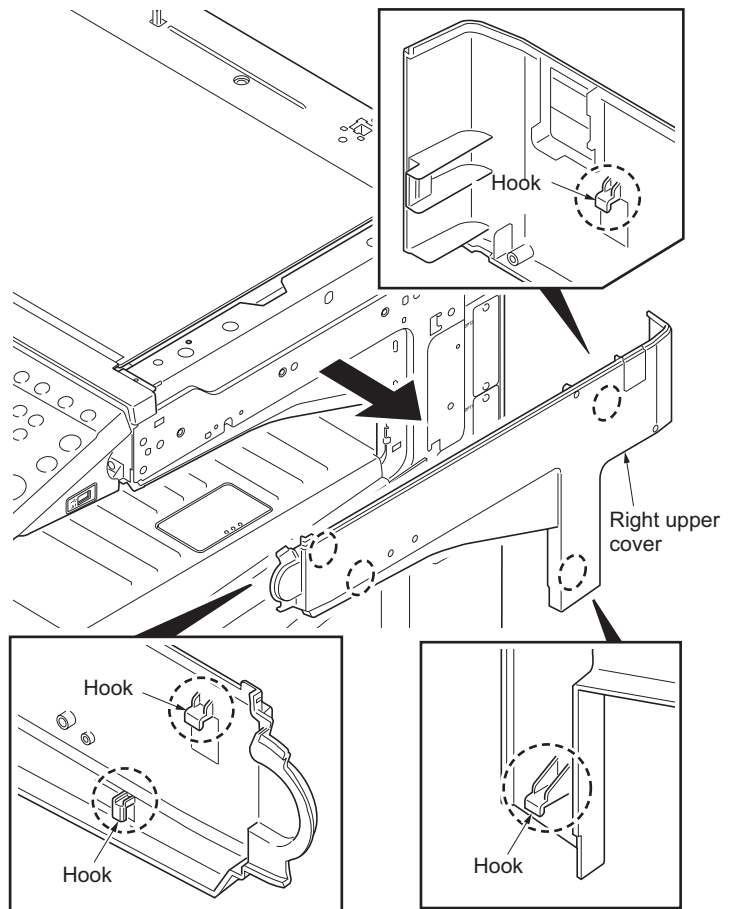

Figure 1-5-10

- 3. Open the front cover.
- 4. Remove the screw and remove the front right cover.

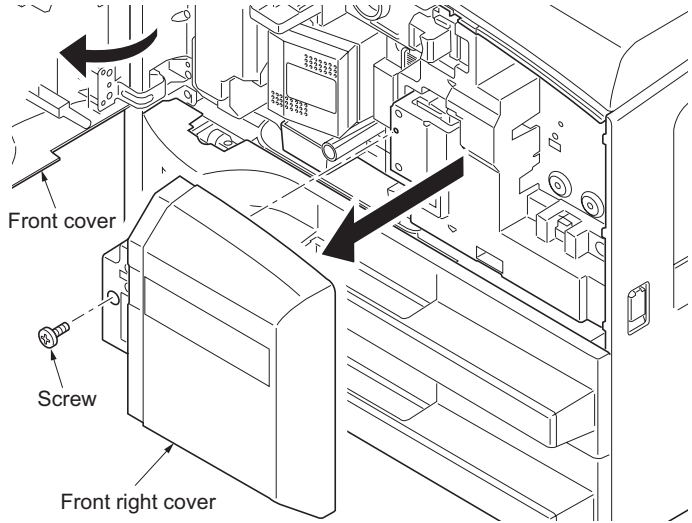

Figure 1-5-11

- 5. Raise the top tray.
- 6. Unhook ten hooks and remove the right lower cover.

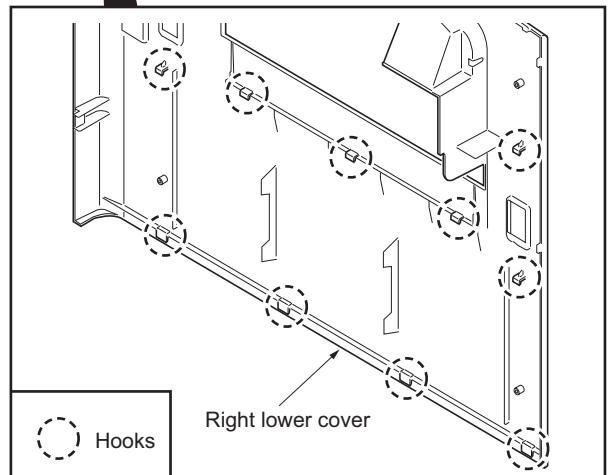
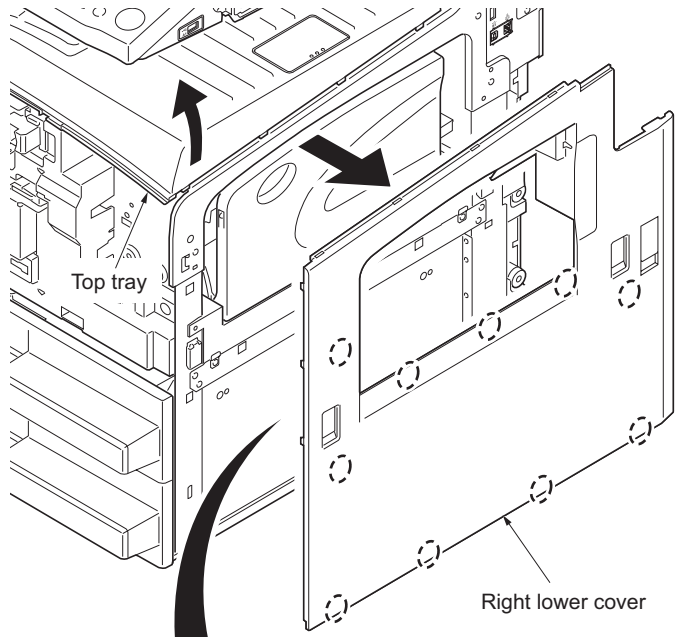

Figure 1-5-12

- 7. Loosen two screws and remove two MP holder plates.
- 8. Remove two screws.

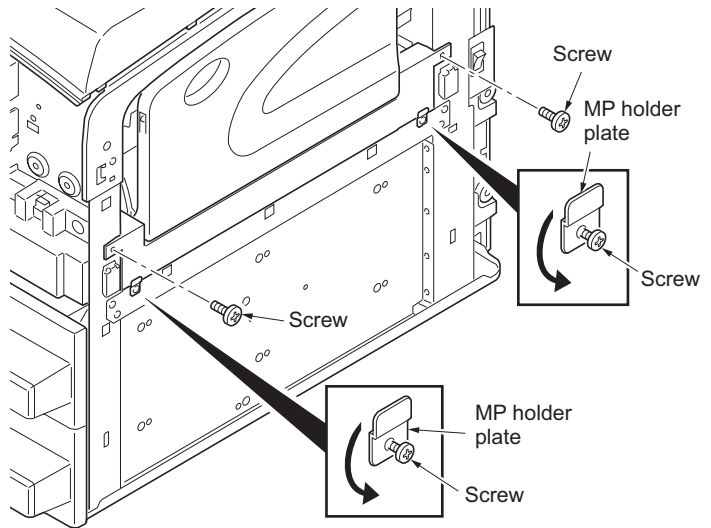

Figure 1-5-13

- 9. Remove two connectors.
- 10. Release the clamp.
- 11. Remove the MP unit.

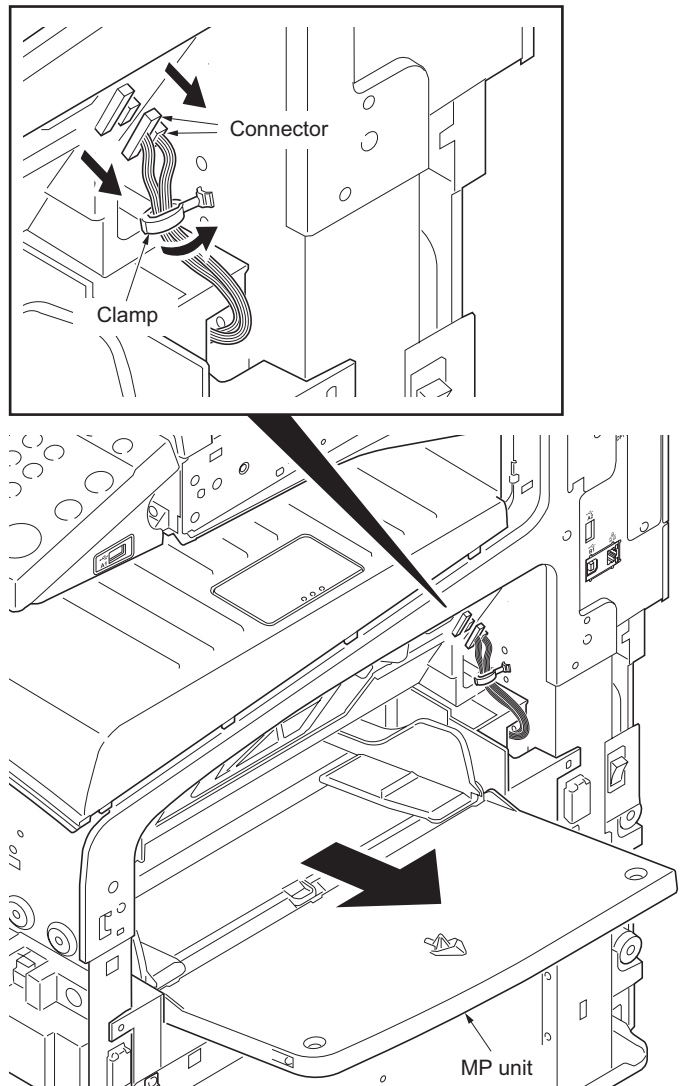

Figure 1-5-14

Removing the MP separation pulley

12. Reverse the MP unit and remove the spring and stop ring from the MP separation pulley shaft.
13. Move the bush inside.

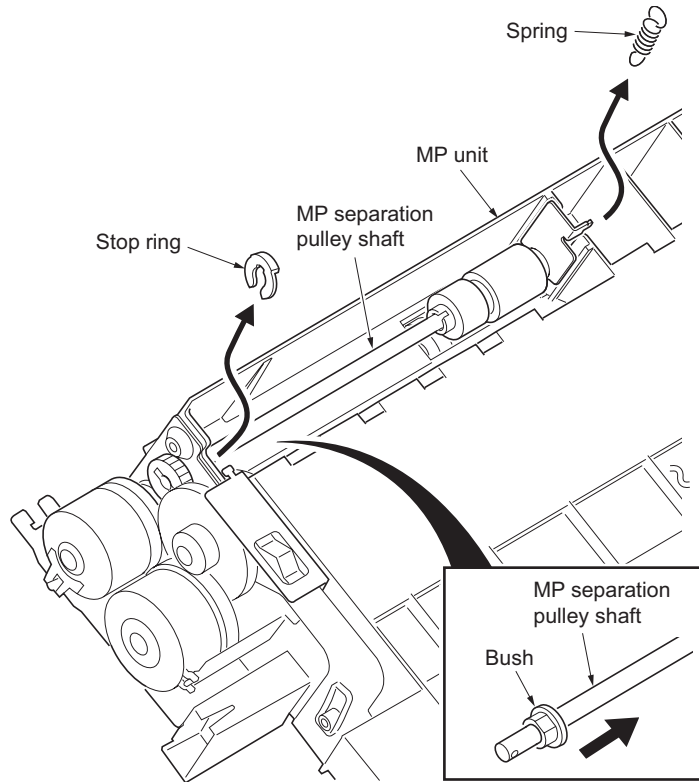

Figure 1-5-15

14. Raise the MP separation pulley shaft. Remove the holder plate and the bush, and then remove the MP separation pulley.

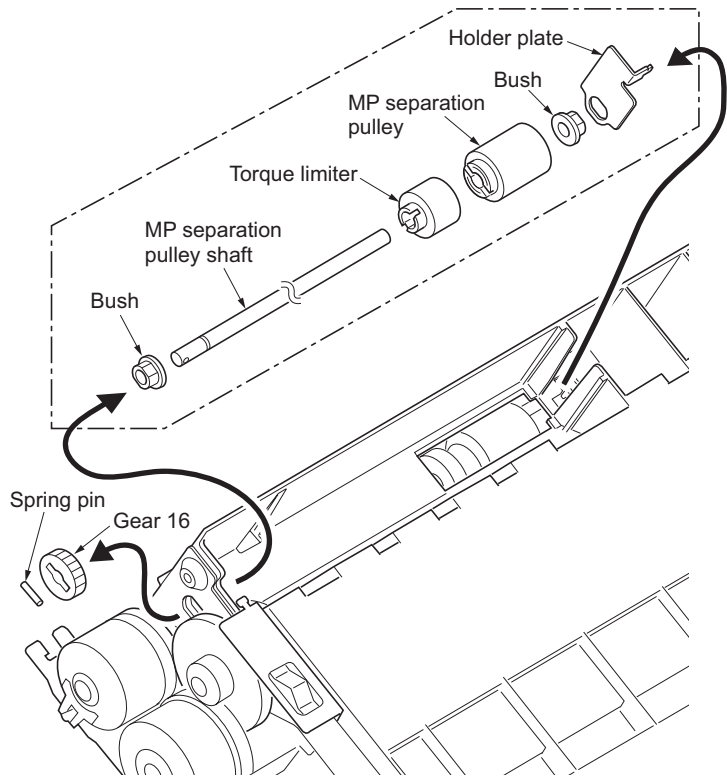

Figure 1-5-16

Removing the MP paper feed pulley

- 15. Remove the connector.
- 16. Release three clamps and remove the wire.

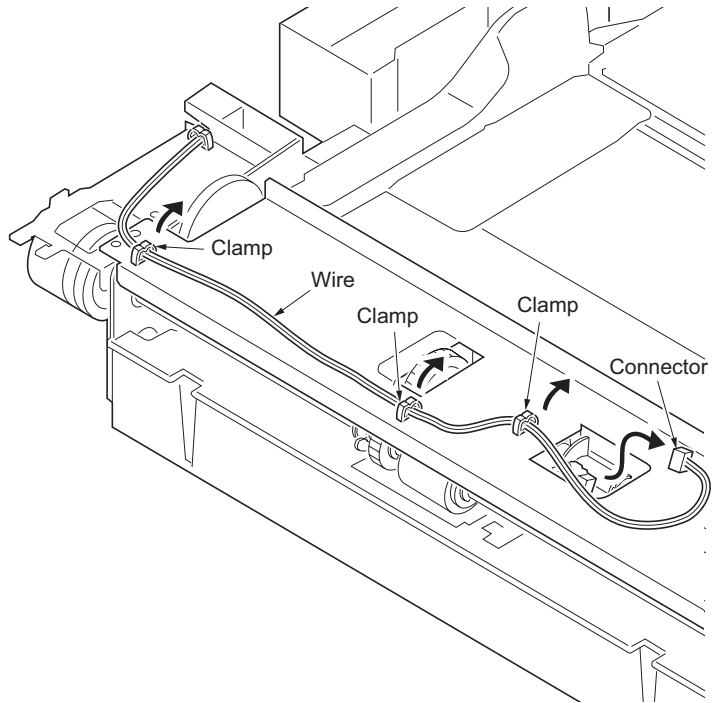

Figure 1-5-17

- 17. Remove the screw and remove the MP unit cover.

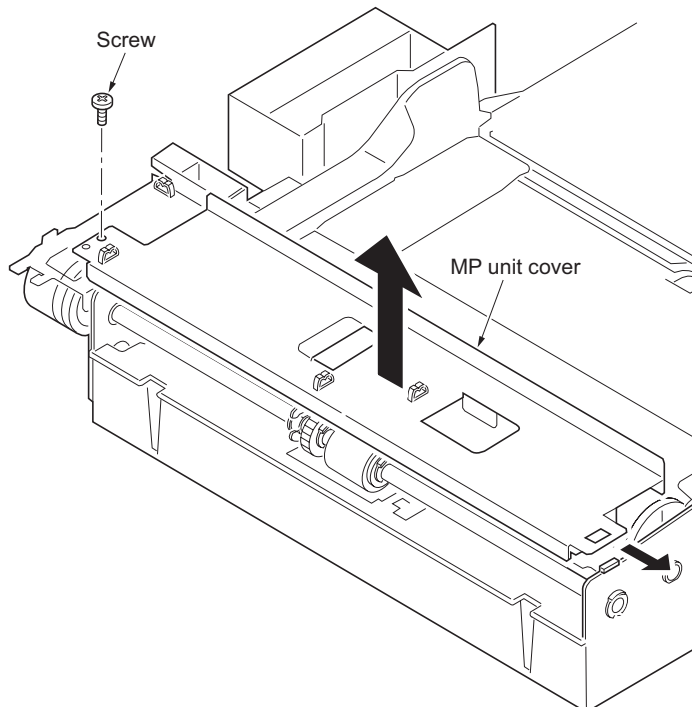

Figure 1-5-18

18. Remove the stop ring and bush.

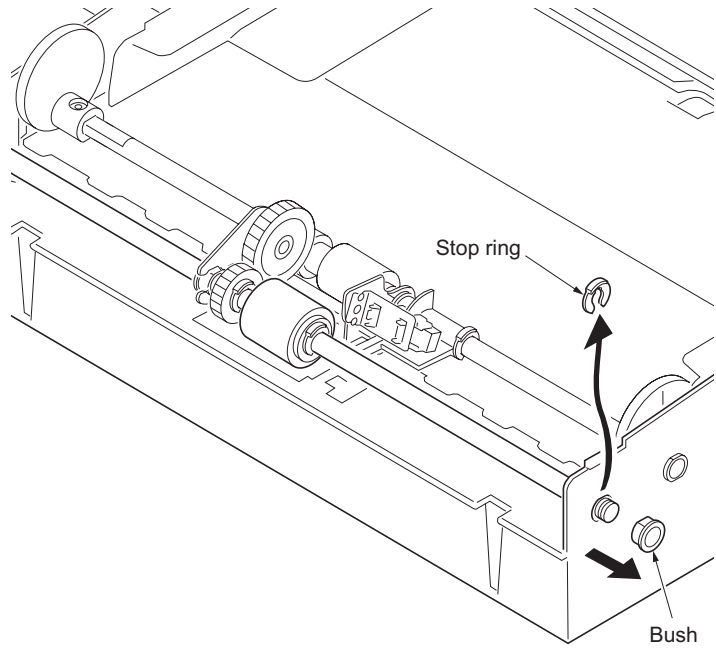

Figure 1-5-19

19. Remove the stop ring.
20. Raise the MP paper feed pulley shaft and remove the MP paper feed pulley.

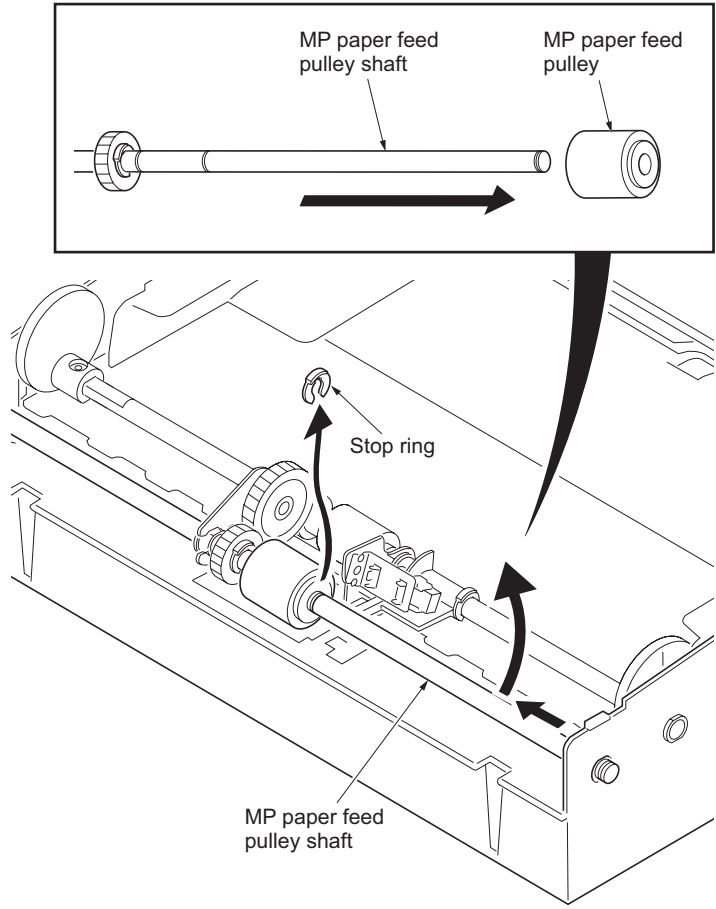
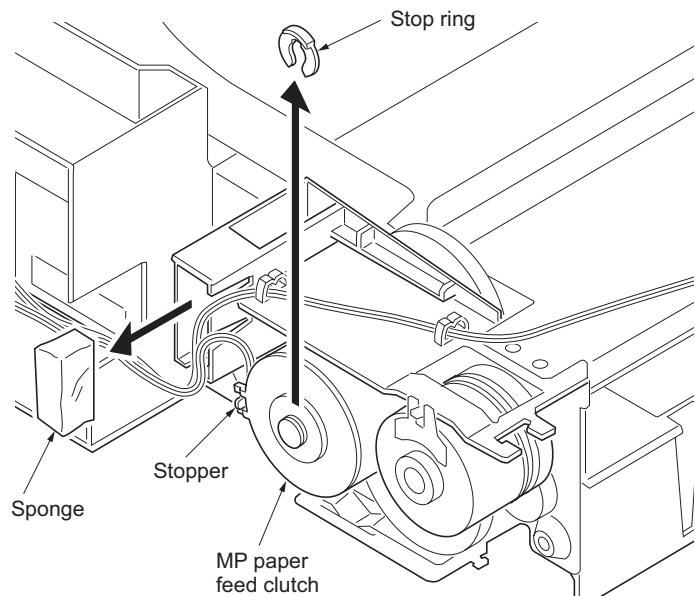

Figure 1-5-20

Removing the MP forwarding pulley

21. Remove the sponge.
22. Remove the stop ring and MP paper feed clutch.
When refitting, insert the cutout in the MP paper feed clutch over the stopper on the machine.

**Figure 1-5-21**

23. Remove the screw and move the cam and the bush toward the inner side.

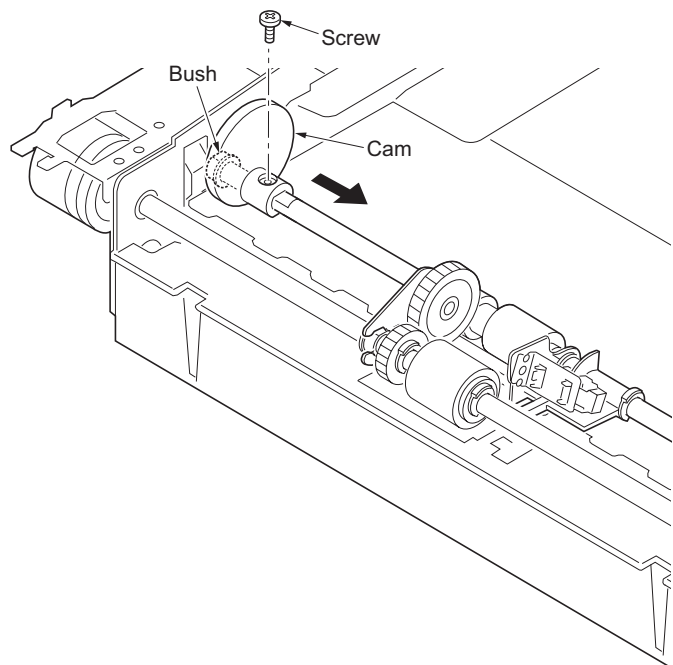
**Figure 1-5-22**

24. Remove the stop ring and slide the bush in the direction of the arrow.

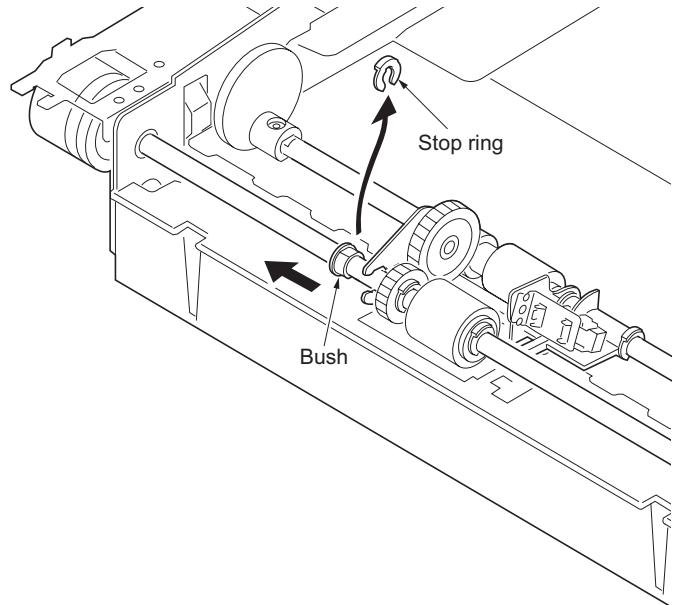

Figure 1-5-23

25. Slide the MP forwarding pulley shaft temporarily toward the rear side and then raise it to remove from the MP unit. Remove the shaft while raising the actuator of the MP paper switch.

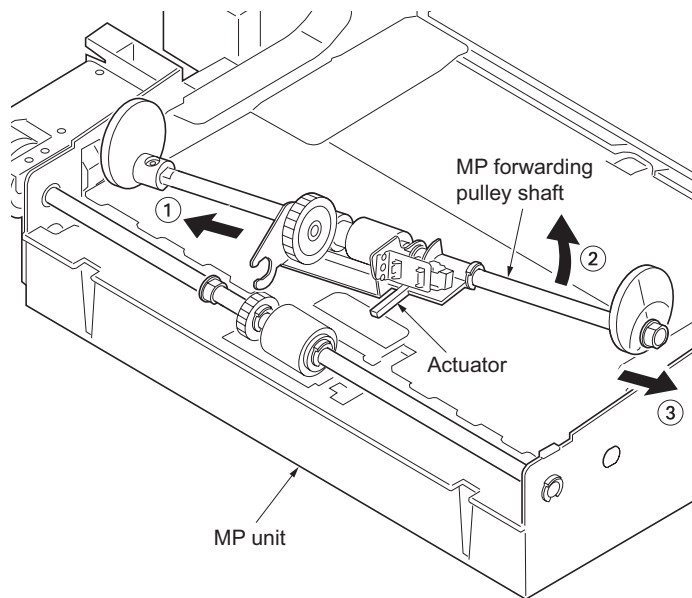

Figure 1-5-24

- 26. Remove the bush and cam.
- 27. Remove the stop ring.
- 28. Slide the MP forwarding pulley with the forwarding pulley retainer from the shaft to remove it.
- 29. Replace the MP separation, MP paper feed and MP forwarding pulleys.

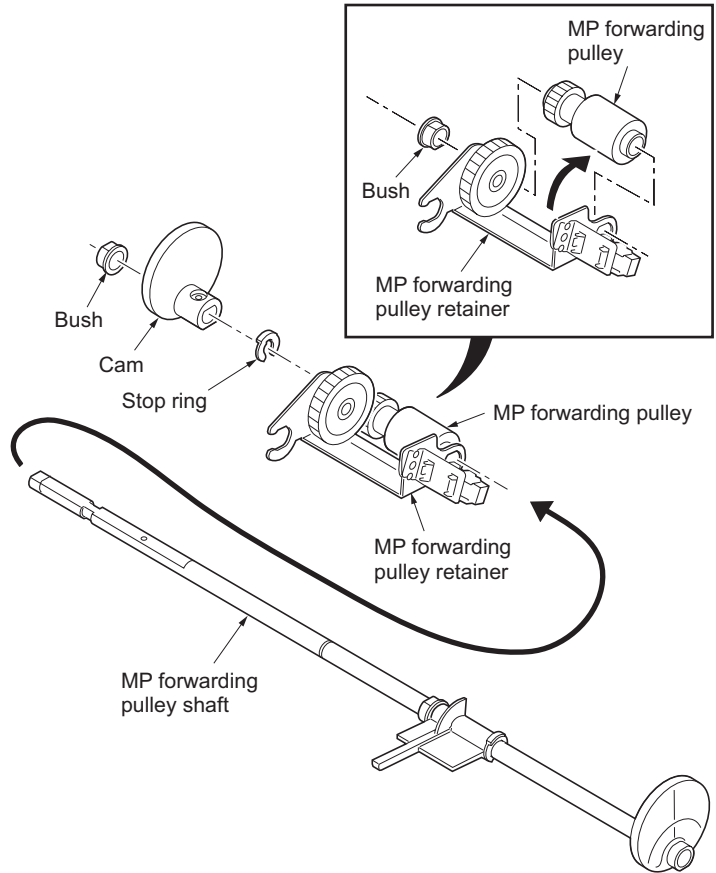

Figure 1-5-25

- 30. Refit all the removed parts.
When refitting the MP unit cover, the films on the cover are positioned under the MP paper feed pulley shaft.
- 31. When the MP forwarding pulley, MP paper feed pulley or the MP separation pulley is replaced, perform maintenance mode U901 to clear the counter value (see page 1-3-84).

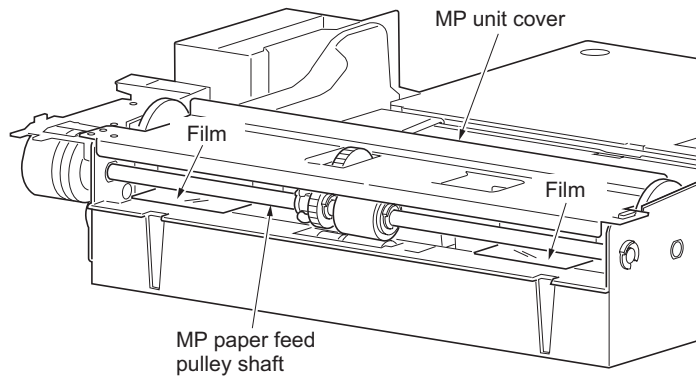

Figure 1-5-26

1-5-3 Optical section

(1) Detaching and refitting the exposure lamp

Follow the procedure below to replace the exposure lamp.

Procedure

1. Remove the original cover or the DP.
2. Remove eleven screws and remove the rear cover.

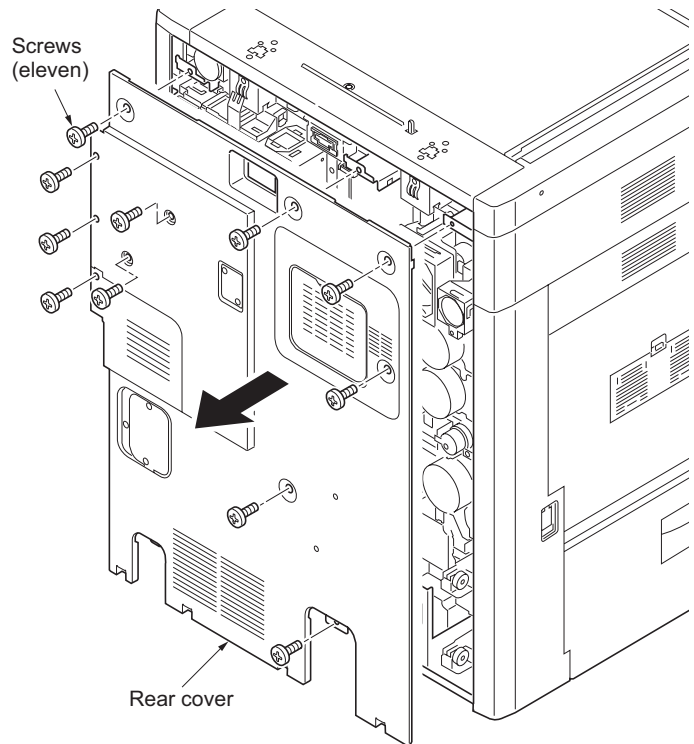

Figure 1-5-27

3. Remove the clip holder.
4. Remove two screws and remove the front left cover.

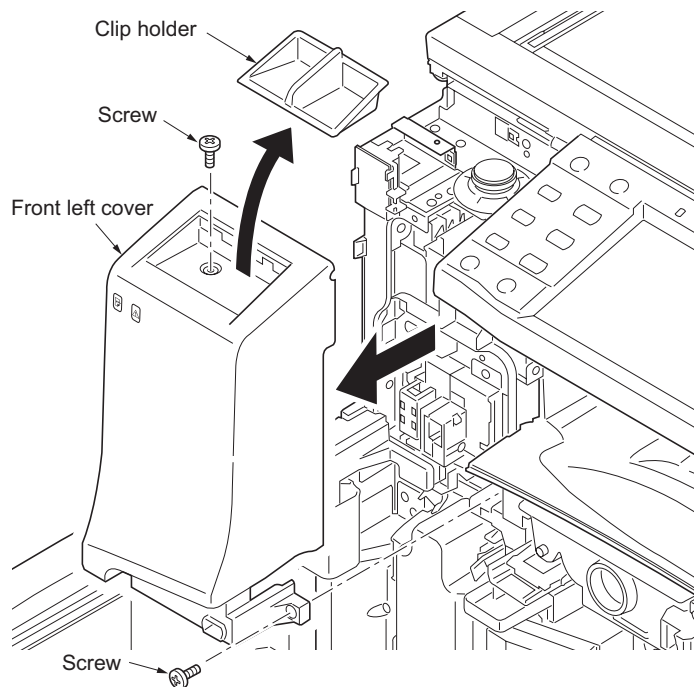

Figure 1-5-28

5. Remove two screws and remove the scanner right cover.
6. Remove the contact glass.

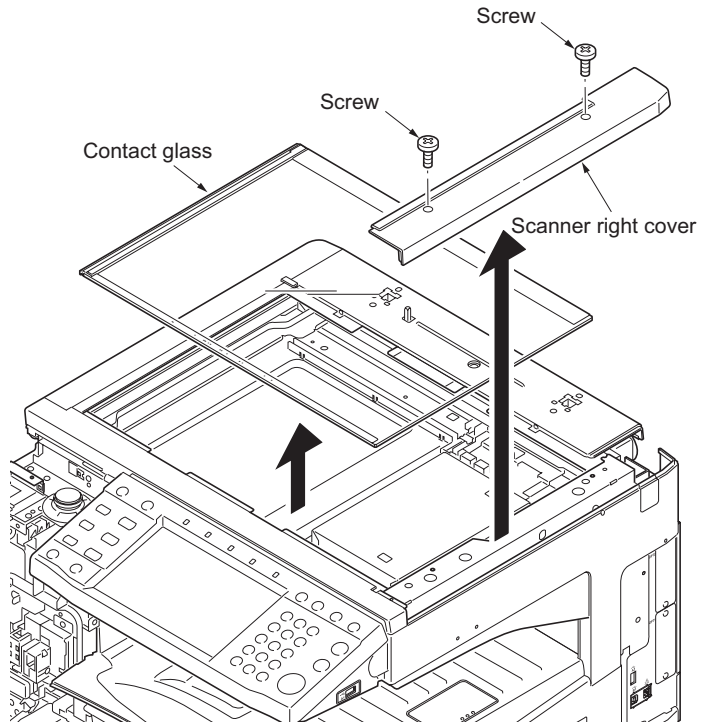

Figure 1-5-29

7. Remove the scanner front cover.
8. Remove the screw and remove the scanner rear cover.

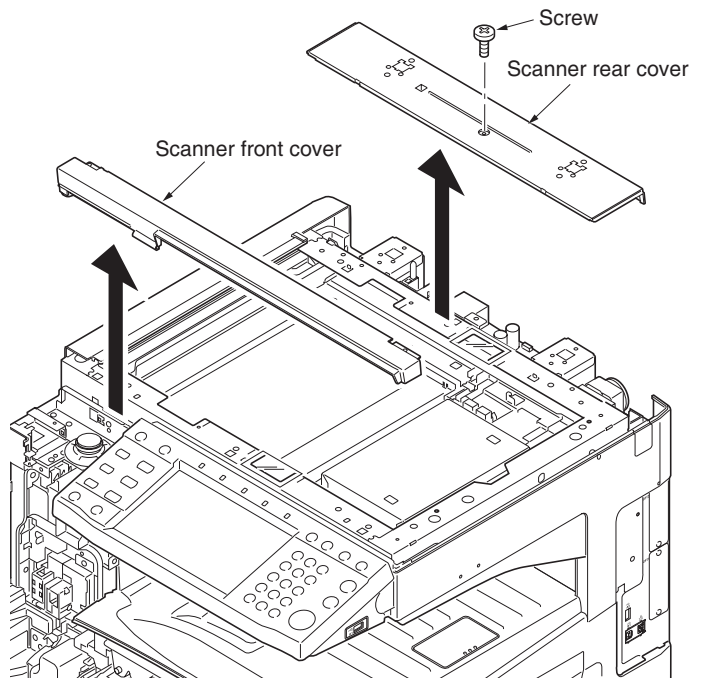

Figure 1-5-30

9. Remove the connector of the inverter PWB.
10. Release the clamp and remove the wire.
11. Pull the connector out from the opening on the rear of the scanner unit.

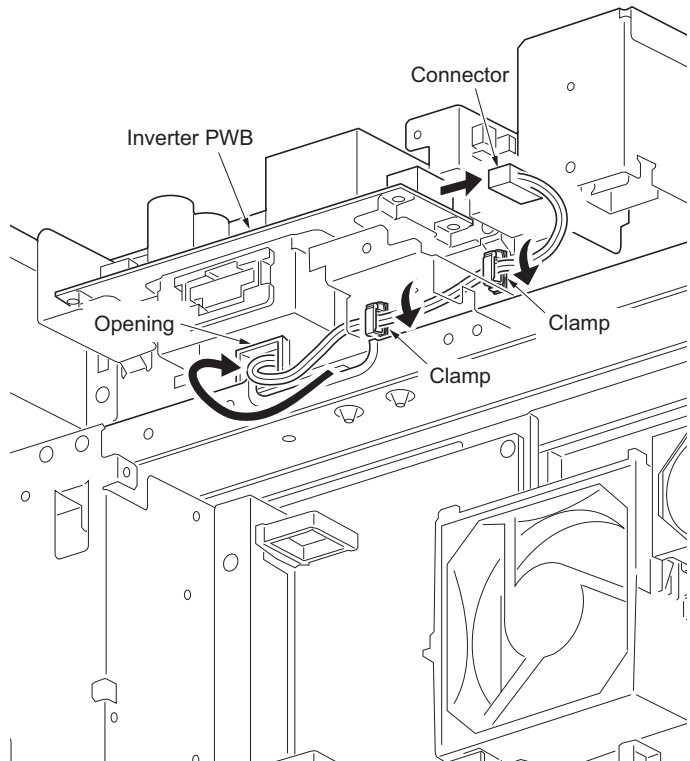

Figure 1-5-31

12. Remove two films.
13. Remove the wire guide lid.
14. Move the mirror 1 frame to notch position.

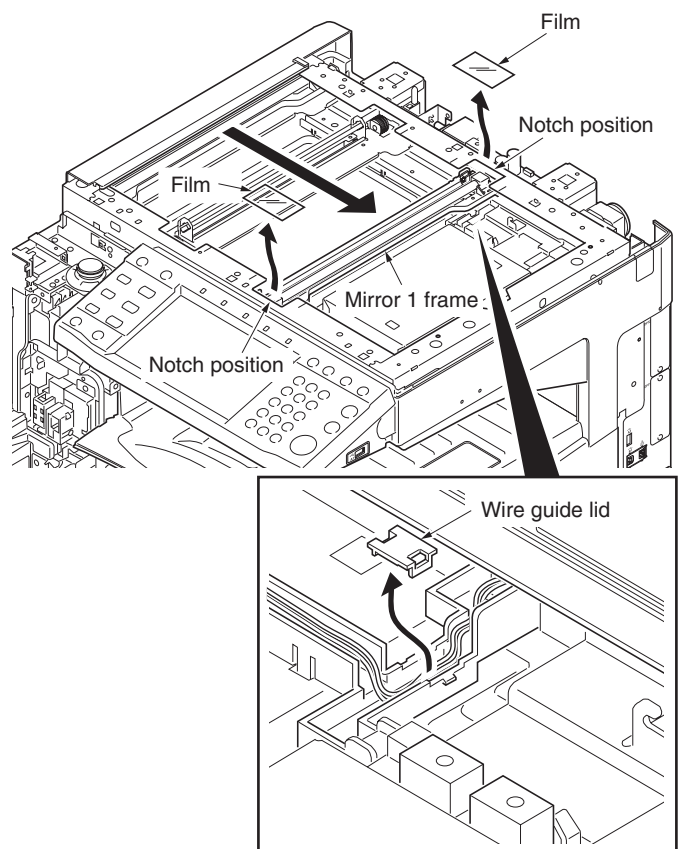

Figure 1-5-32

- 15. Remove the screw.
- 16. Open the lamp wire guide lid.

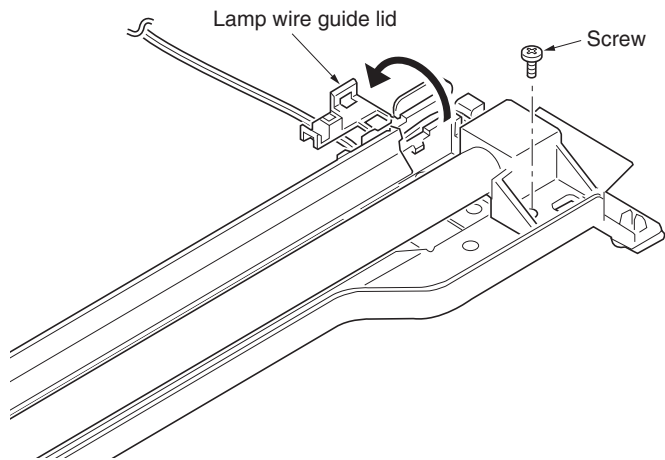

Figure 1-5-33

- 17. Unhook the hook and remove the exposure lamp.
- 18. Replace the exposure lamp and install the lamp.
- 19. Refit all the removed parts.

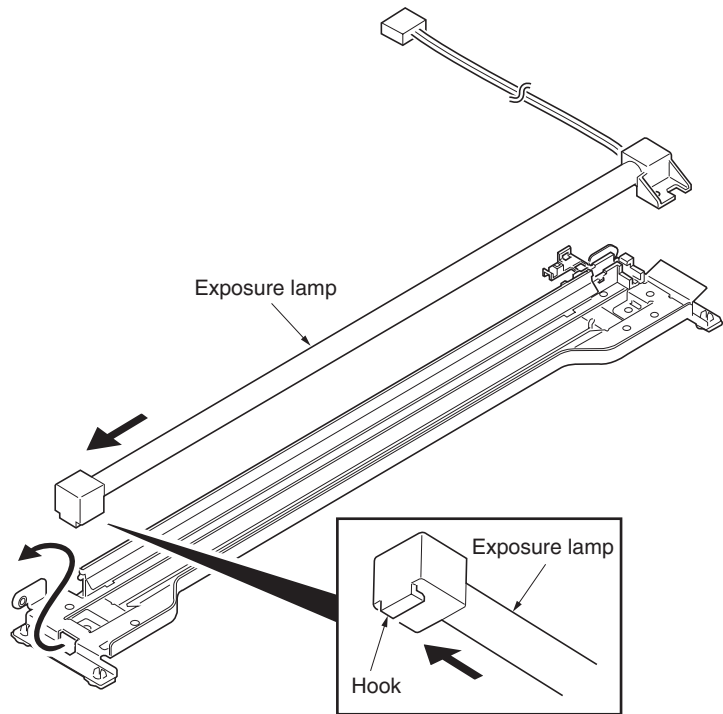

Figure 1-5-34

(2) Detaching and refitting the scanner wires

Take the following procedure when the scanner wires are broken or to be replaced.

(2-1) Detaching the scanner wires

Procedure

1. Remove the scanner unit (see page 1-5-19).
2. Remove the exposure lamp (see page 1-5-15).
3. Remove the screw and remove the slit holder plate.
4. Remove the slit glass.

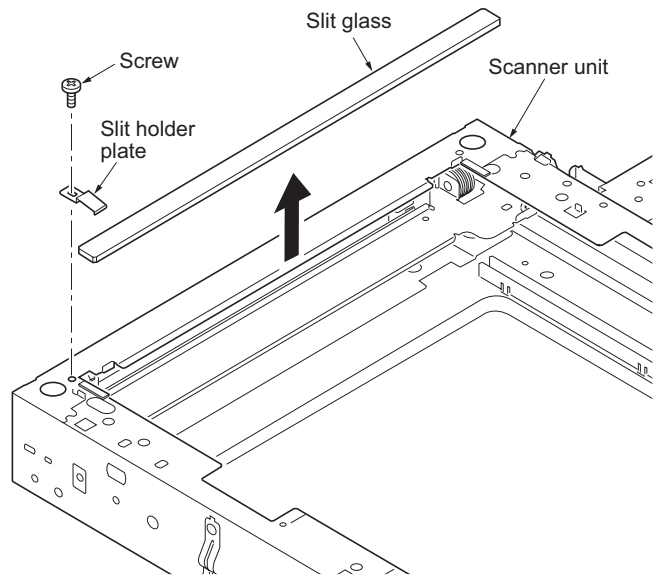

Figure 1-5-35

5. Remove each screw and remove front and rear wire holder plates.
6. Remove the mirror 1 frame from the scanner unit.

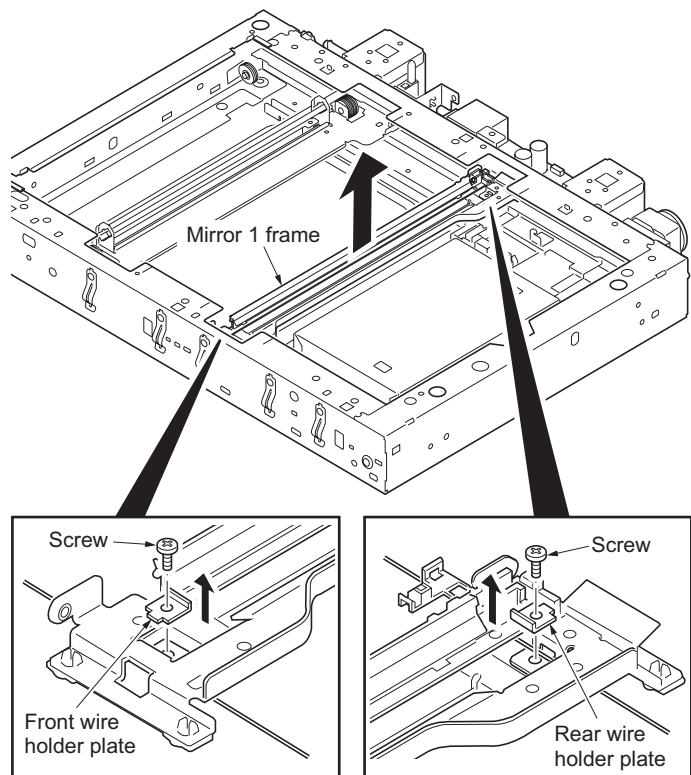

Figure 1-5-36

7. Remove the round terminals from the scanner wire springs.
8. Remove the scanner wires.

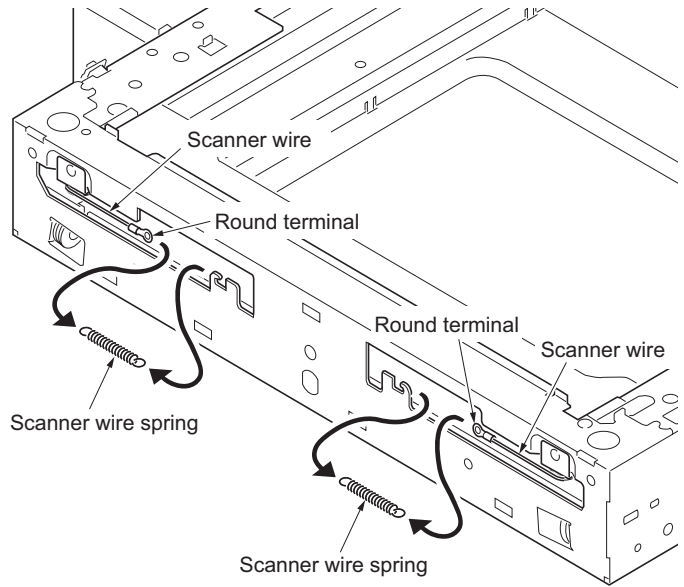

Figure 1-5-37

(2-2) Fitting the scanner wires**NOTE**

When fitting the wires, be sure to use those specified below.

Machine front: (P/N: 2C912360), gray

Machine rear: (P/N: 2C912350), black

Fitting requires the following tools

Two frame securing tools (P/N 302C968310)

Two scanner wire stoppers (P/N 35968110)

Procedure

1. Remove the screw and remove the scanner wire drum gear.

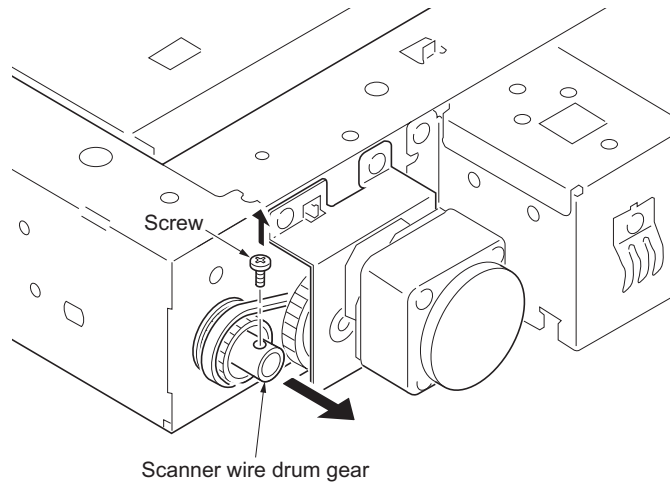

Figure 1-5-38

2. Remove the stop ring and bush from the front of the scanner wire drum shaft.
3. Remove the scanner wire drum shaft from the scanner unit.

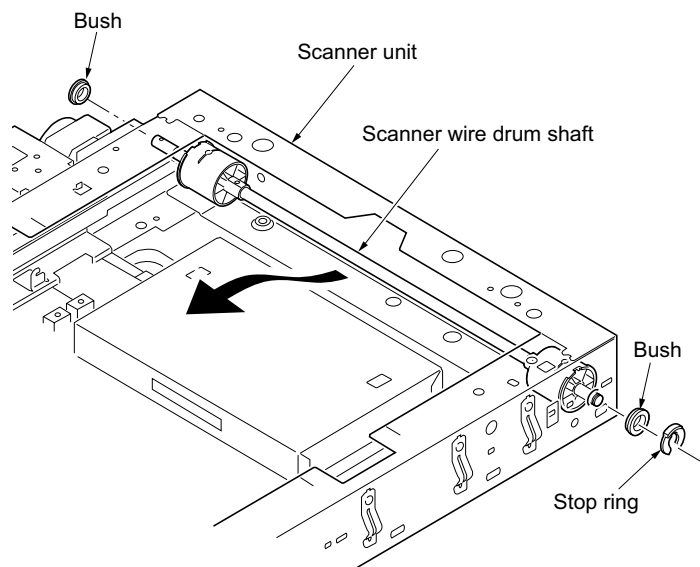

Figure 1-5-39

4. Insert the locating ball on each of the scanner wires into the hole in the respective scanner wire drum and wind the scanner wire three turns inward and four turns outward.
With the locating ball as the reference point, wind the shorter end of each of the wires outward.
5. Secure the scanner wires using the scanner wire stoppers.

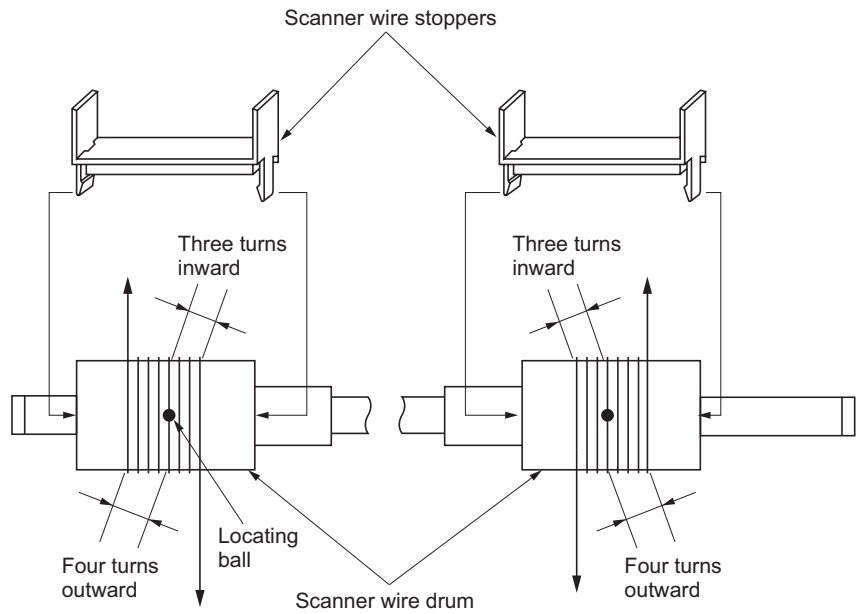

Figure 1-5-40

6. Refit the scanner wire drum shaft to the scanner unit.
7. Insert the two frame securing tools into the positioning holes at the front and rear of the scanner unit to fix the mirror 2 frame in position.

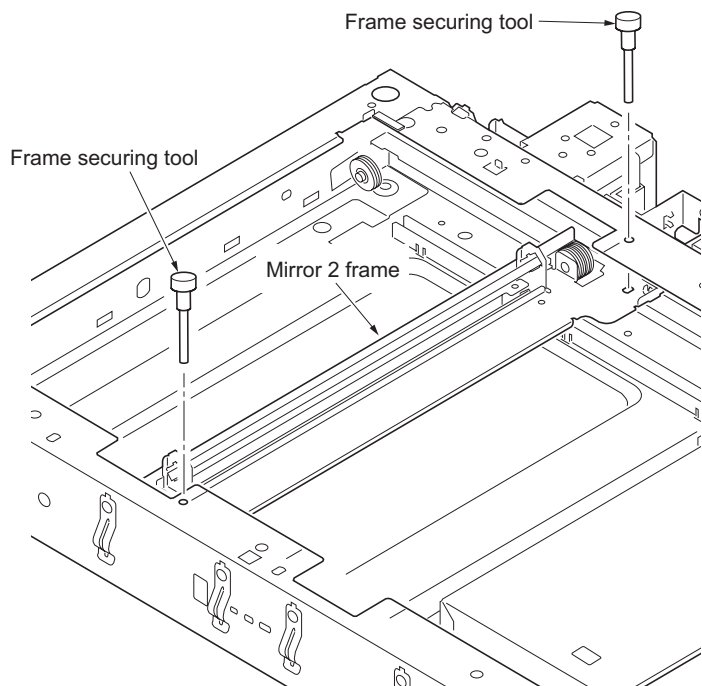

Figure 1-5-41

8. Loop the outer ends of the scanner wires around the outer grooves in the pulleys on the mirror 2 frame, winding from below to above. (1)
9. Hook the round terminals onto the catches inside the scanner unit. (2)
10. Loop the inner ends of the scanner wires around the grooves in the pulleys at the left of the scanner unit, winding from below to above. (3)
11. Loop the scanner wires around the inner grooves in the pulleys on the mirror 2 frame, winding from above to below. (4)
12. Wind the scanner wires around the grooves in the scanner wire guides at the left of the scanner unit. (5)
13. Hook the round terminals onto the scanner wire springs. (6)

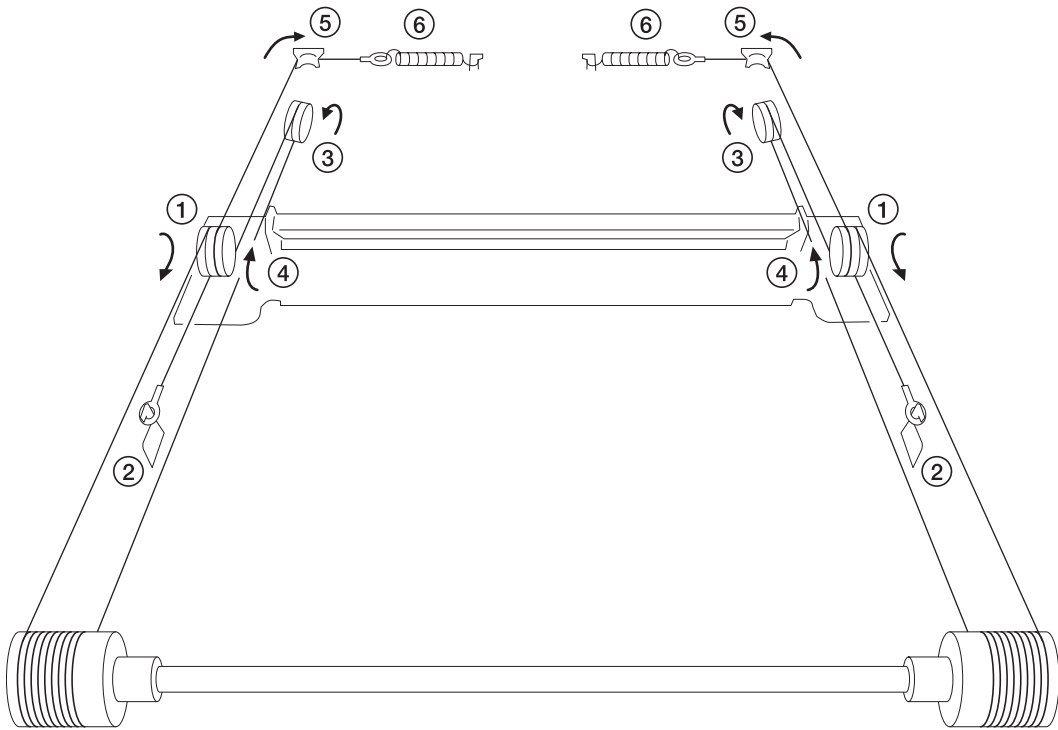

Figure 1-5-42

14. Remove the two scanner wire stoppers and frame securing tools.
15. Focusing on the locating ball of the wire drum, move aside the wires to inside.
16. Move the mirror 2 frame from side to side to correctly locate the wires in position.
17. Refit the mirror 1 frame.
18. Move the mirror 1 and 2 frames to the machine left, and insert the two frame securing tools into the positioning holes at the front and rear of the scanner unit to secure the frames in position.
19. Hold the wires and fix each front and rear wire holder plate to mirror 1 frame with the screw.
20. Remove the two frame securing tools.
21. Refit all the removed parts.

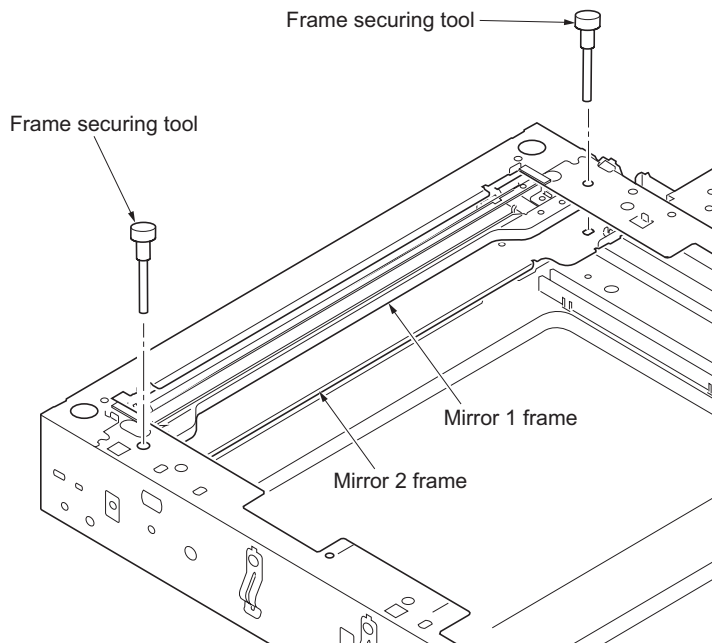

Figure 1-5-43

(3) Detaching and refitting the ISU (reference)

Follow the procedure below to replace the ISU.

Procedure

1. Remove two screws and remove the scanner right cover.
2. Remove the contact glass.

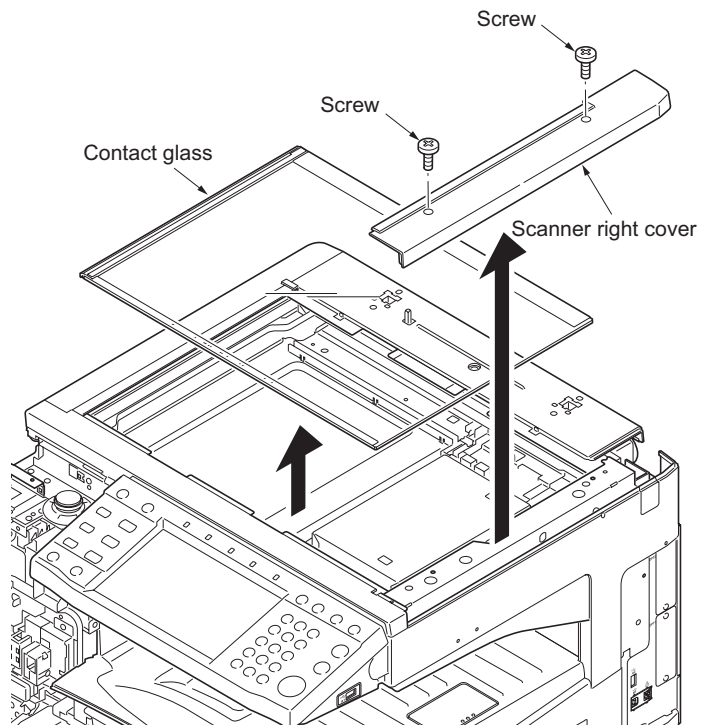

Figure 1-5-44

3. Remove six screws and remove the FFC ground and ISU cover.

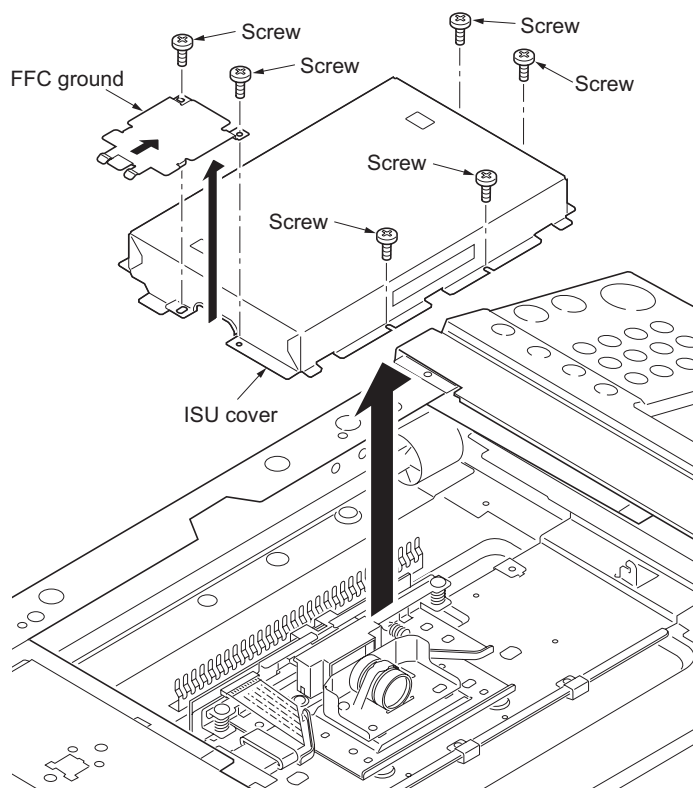

Figure 1-5-45

4. Remove the FFC from the connector.
5. Remove four screws and remove the ISU.
6. Replace the ISU.
7. Refit all the removed parts.

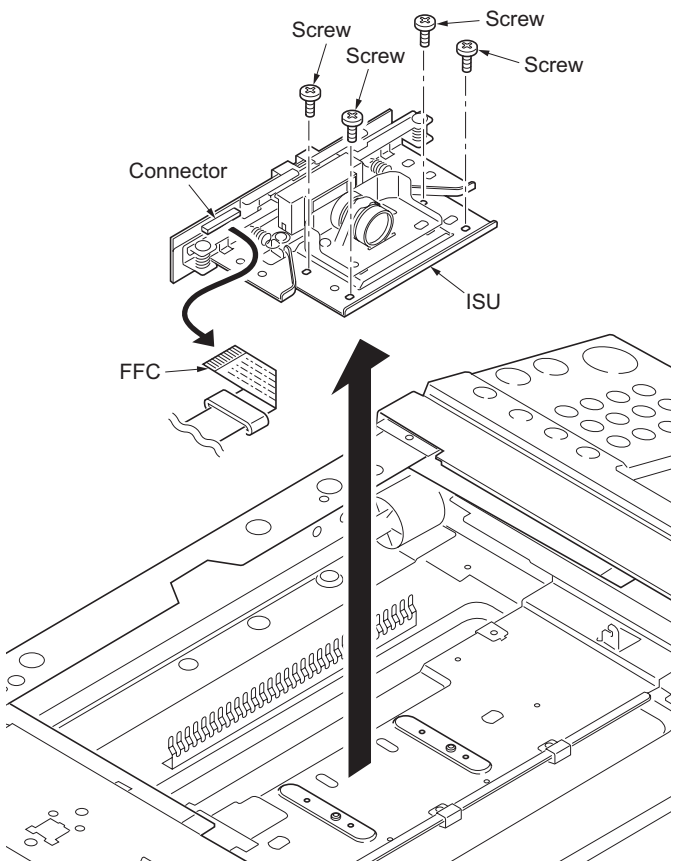

Figure 1-5-46

(4) Detaching and refitting the laser scanner unit

Follow the procedure below to replace the laser scanner unit.

Procedure

1. Open the front cover.
2. Remove the toner container.
3. Remove the waste toner box.
4. Remove the screw and remove the front right cover.

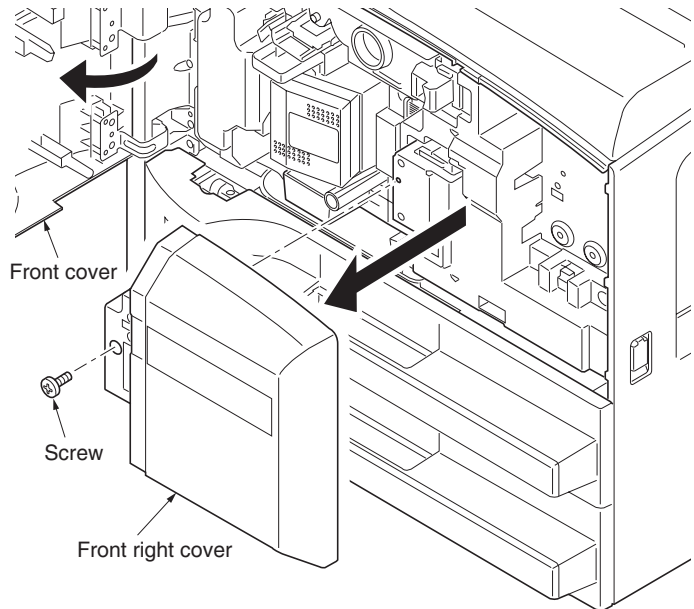

Figure 1-5-47

5. Remove the and remove the toner hopper wire cover.

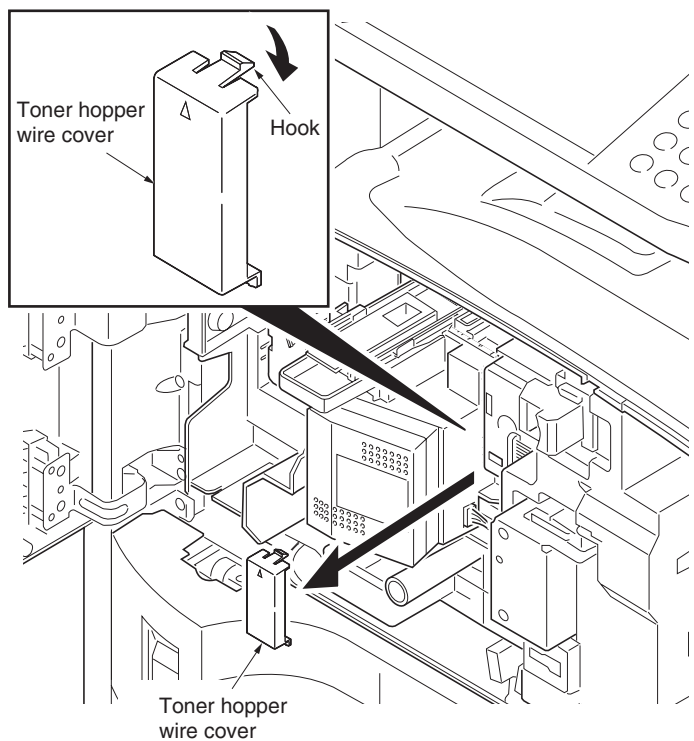

Figure 1-5-48

- 6. Remove three screws.
- 7. Remove the connector.
- 8. Remove the toner hopper assembly.

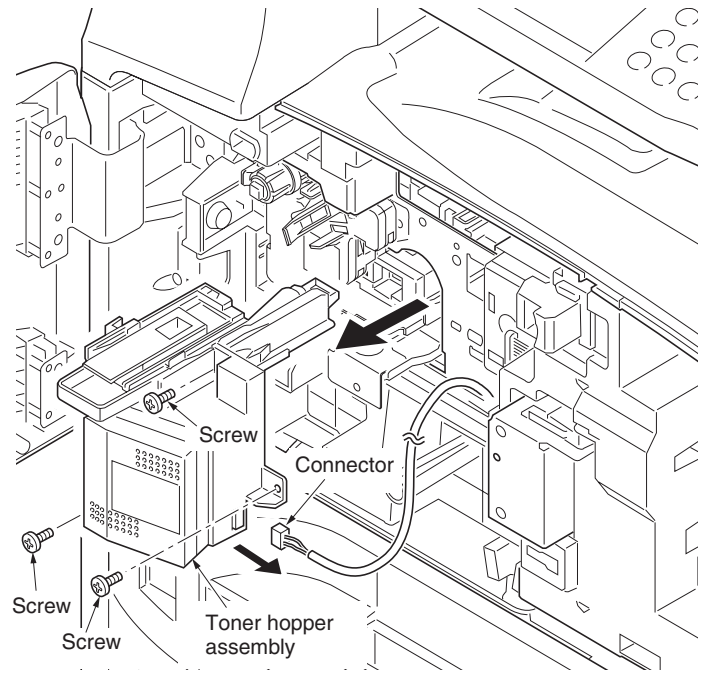

Figure 1-5-49

- 9. Remove the top tray.

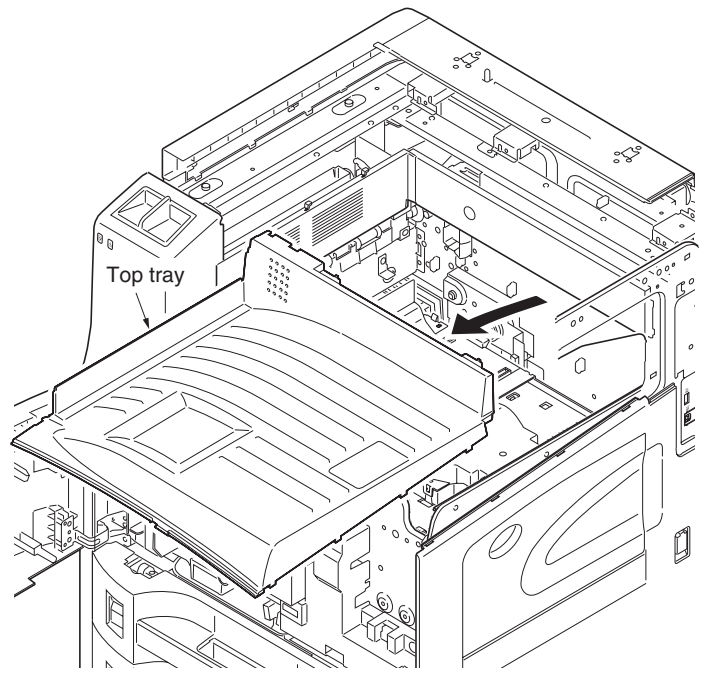

Figure 1-5-50

- 10. Remove the clamp A.
- 11. Release two clamps B.
- 12. Remove six connectors.

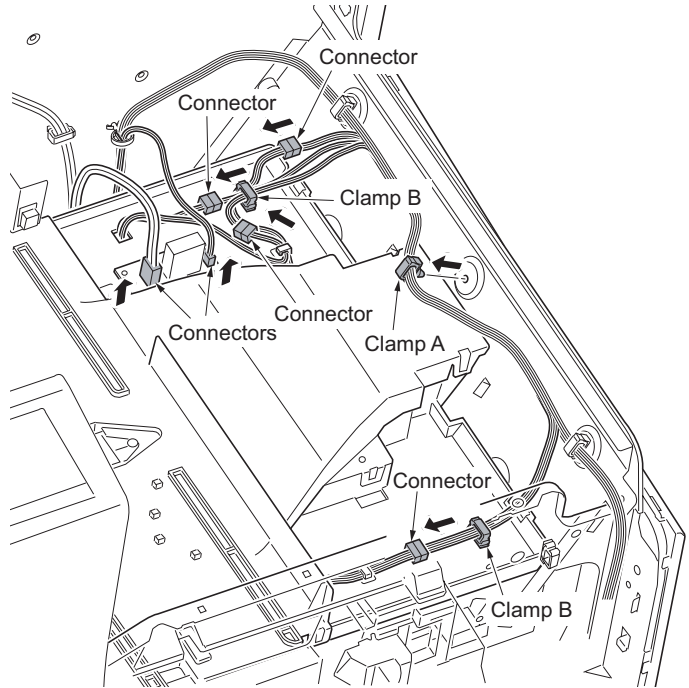

Figure 1-5-51

- 13. Remove two screws and remove the cooling fan assembly.

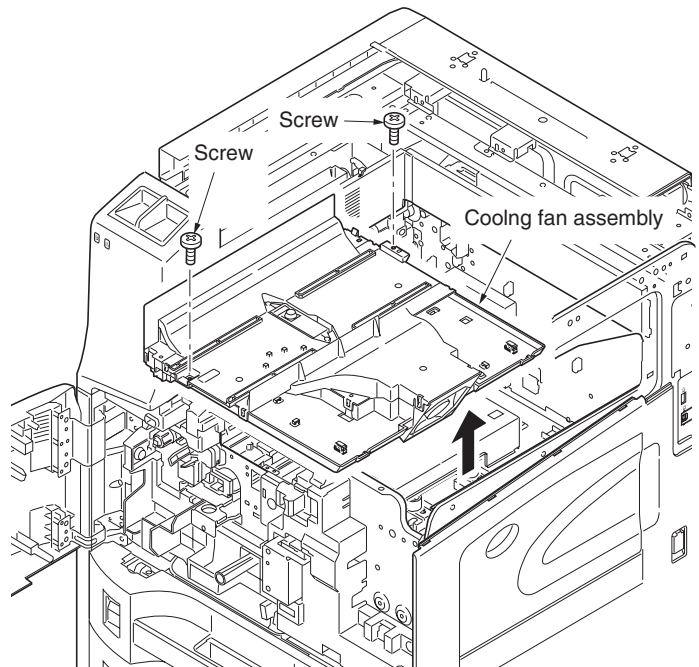

Figure 1-5-52

14. Remove three screws and remove the LSU cover.

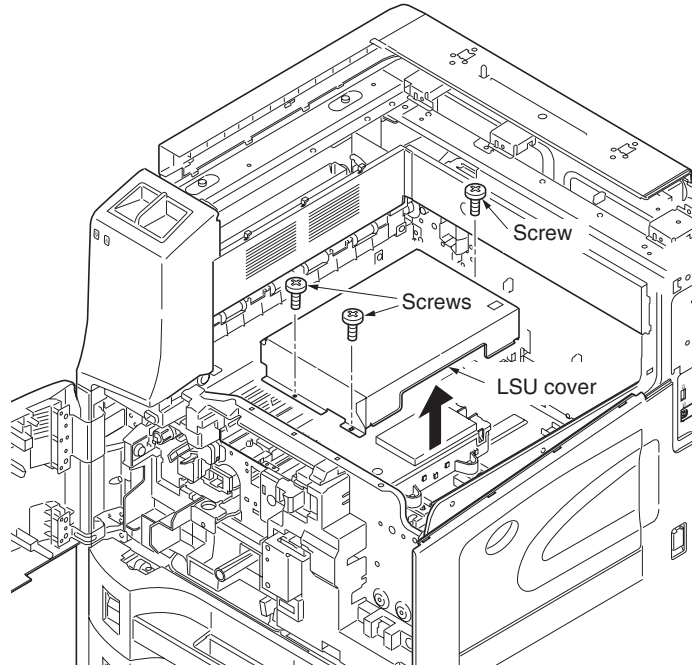

Figure 1-5-53

15. Remove two connectors.
 16. Remove four screws and remove the laser scanner unit.
 17. Replace the laser scanner unit and install the unit.
 18. Refit all the removed parts.

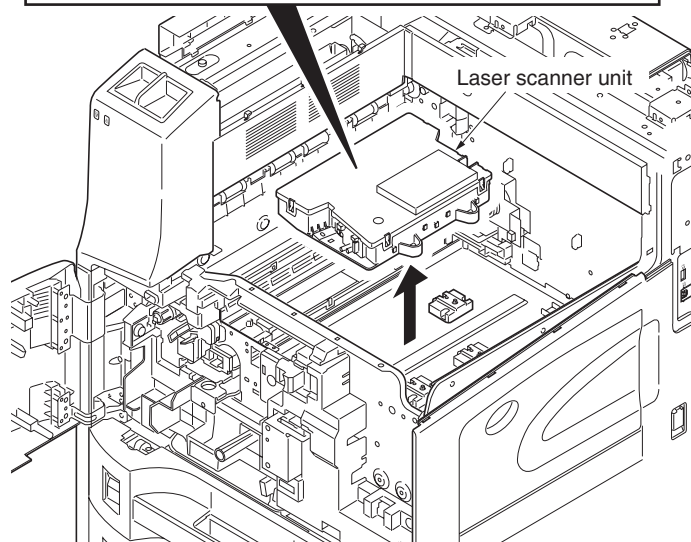
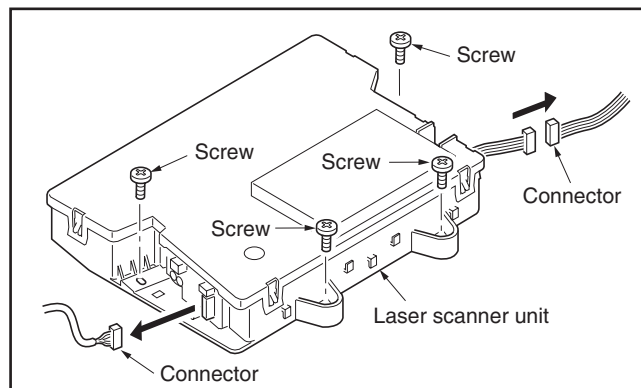

Figure 1-5-54

(5) Adjusting the position of the ISU (reference)

Perform the following adjustment if the leading and trailing edges of the copy image are laterally skewed (lateral squareness not obtained).

Caution:

Adjust the deflection in the paper at the registration roller first (see page 1-3-25). Check for the longitudinal squareness of the copy image, and if it is not obtained, perform the longitudinal squareness adjustment.

Before making the following adjustment, print the test pattern in maintenance item U402 to use as the original for the adjustment.

Procedure

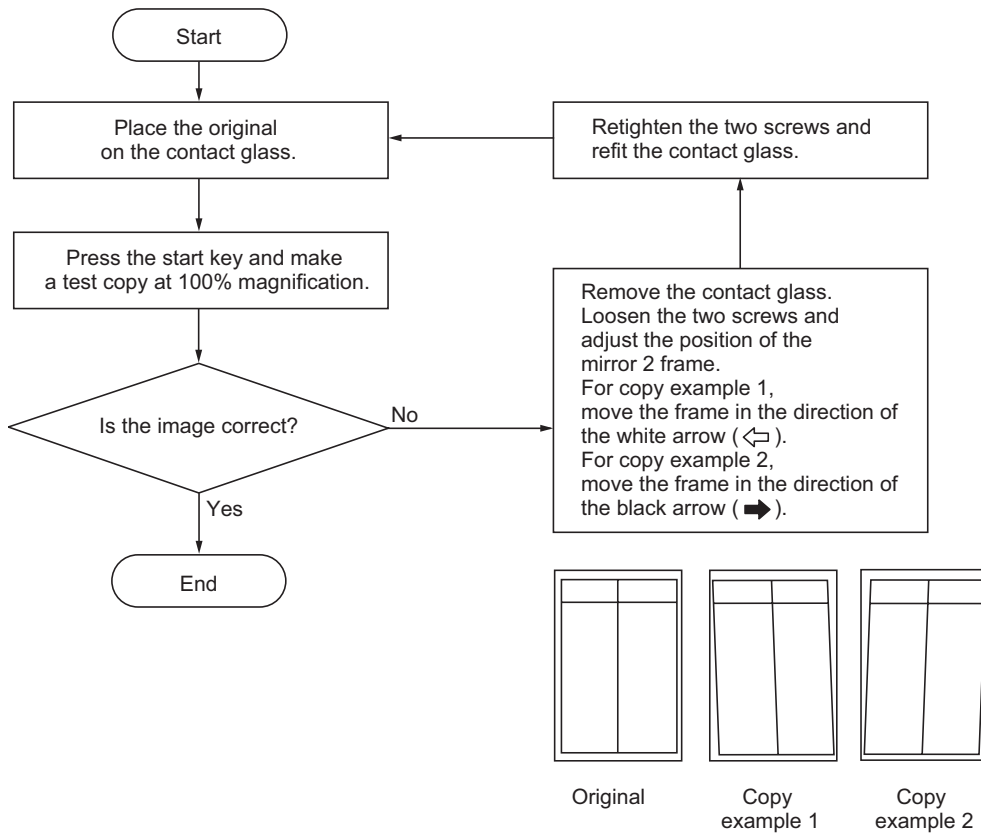

Figure 1-5-55

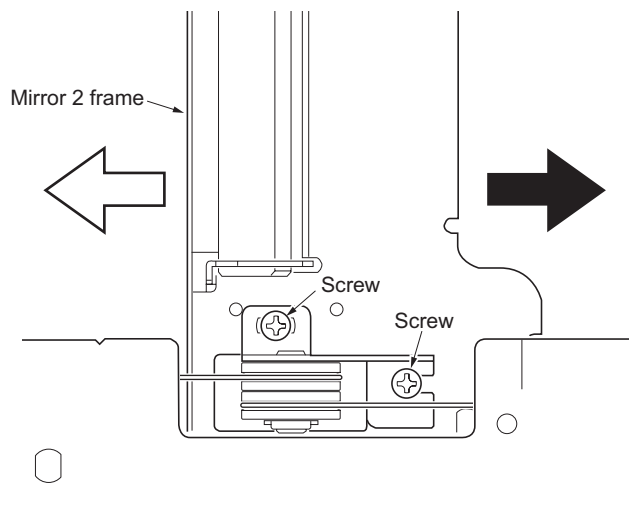

Figure 1-5-56

1-5-4 Drum section

(1) Detaching and refitting the drum unit

Follow the procedure below to replace the drum unit.

Cautions

Avoid direct sunlight or strong light when detaching and refitting the drum unit.
Never touch the drum surface when holding the drum unit.

Procedure

1. Open the left cover 1.
2. Open the front cover.
3. Remove the toner container.
4. Remove the waste toner box.
5. Unhook the hook and remove the toner hopper wire cover.

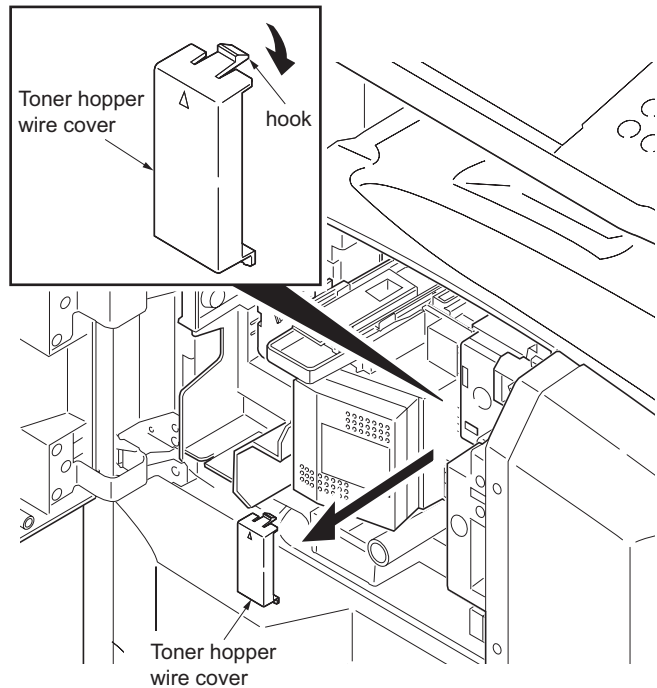

Figure 1-5-57

6. Remove the connector.
7. Remove three screws.
8. Remove the toner hopper assembly.

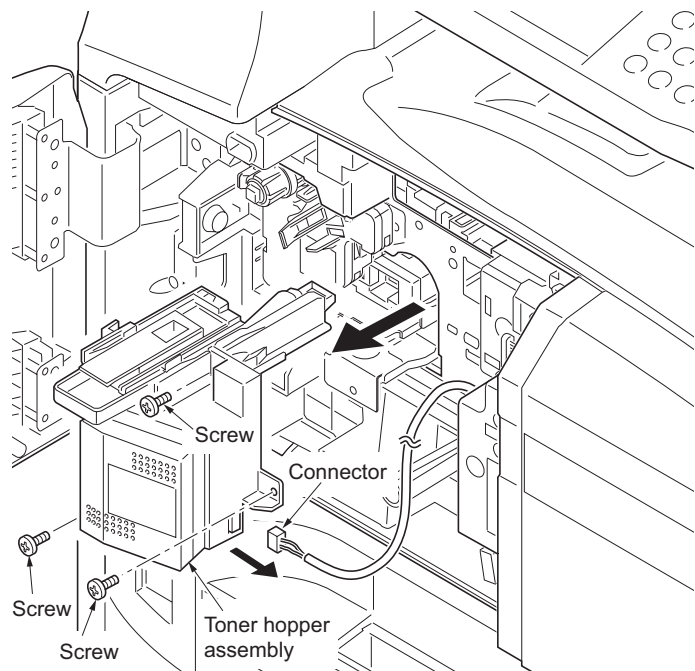

Figure 1-5-58

- 9. Unhook the hook and remove the inner cover lid.
- 10. Remove two connectors.
- 11. Pull the developing lever.

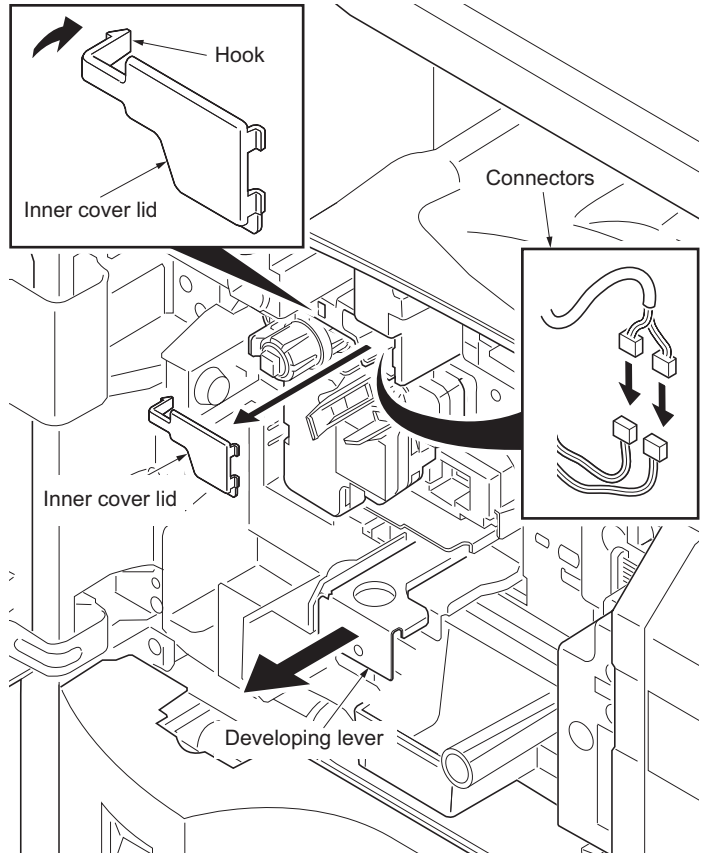

Figure 1-5-59

- 12. Remove the screw and remove the drum unit.
- 13. Replace the drum unit and install the unit.
- 14. When the drum unit is replaced with a new one, carry out the following procedure.
- 15. Perform maintenance mode U410 (Adjusting the halftone automatically) (see page 1-3-75).

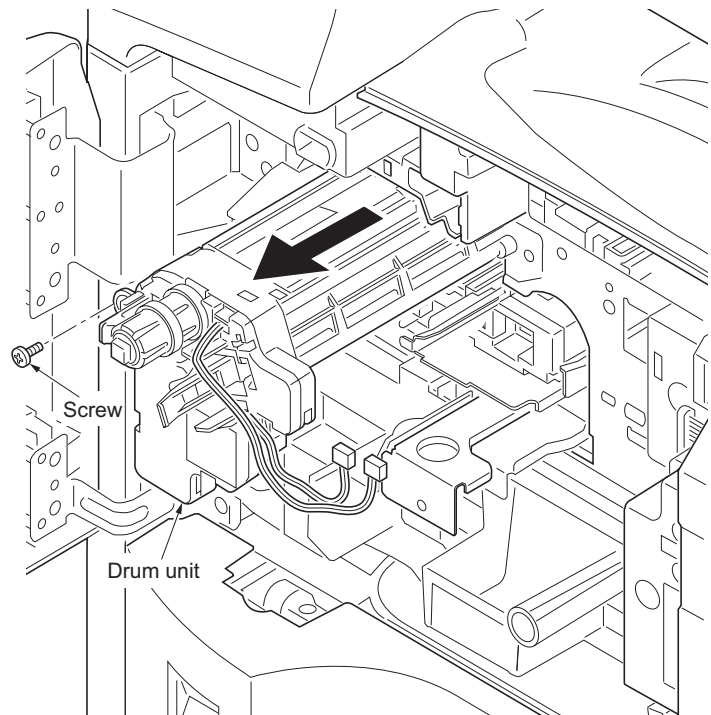

Figure 1-5-60

(2) Detaching and refitting the main charger unit

Follow the procedure below to replace the main charger unit.

Procedure

1. Open the front cover.

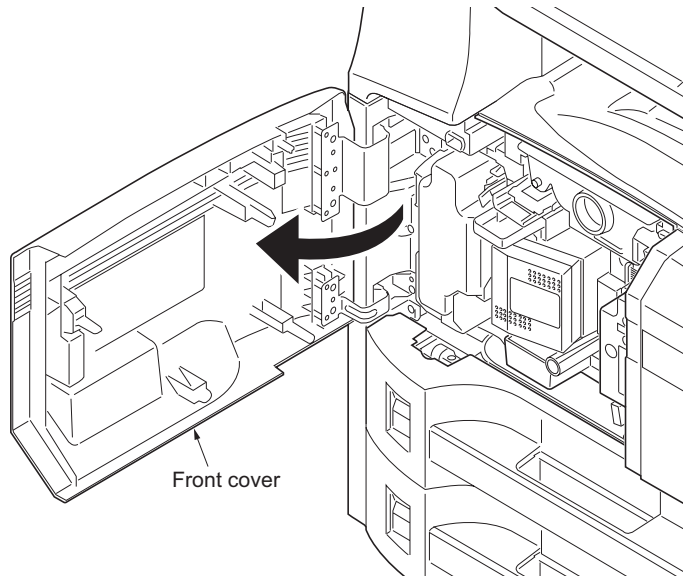

Figure 1-5-61

2. Pull the main charger unit.
3. While pressing the lock lever and remove the main charger unit.
4. Replace the main charger unit and install the unit.
The main charger unit, when fully inserted, must be set aside towards the drum unit.

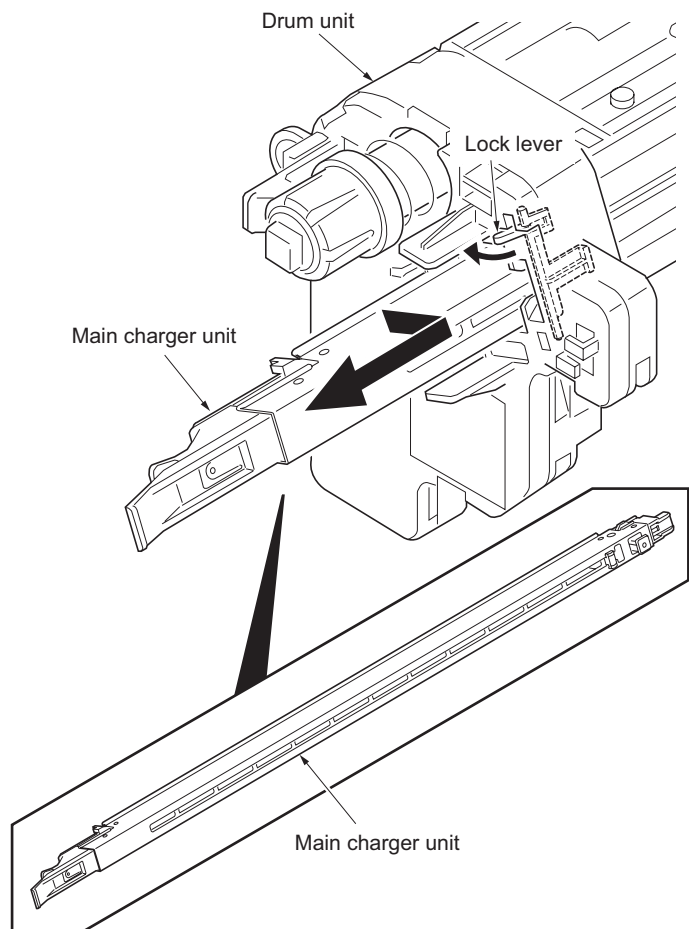

Figure 1-5-62

(3) Detaching and refitting the drum separation claws

Follow the procedure below to replace the drum separation claws.

Procedure

1. Remove the drum unit (see page 1-5-34).
2. Remove two screws and remove the lower cleaning seal.

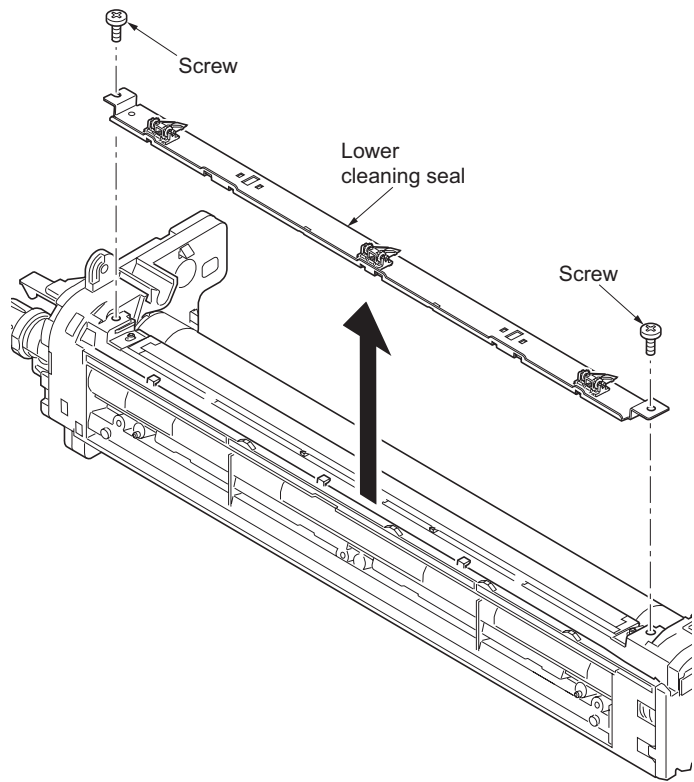

Figure 1-5-63

3. Release the inserted parts and remove the drum separation claws.
4. Replace the drum separation claws and install the claws.
5. Refit all the removed parts.

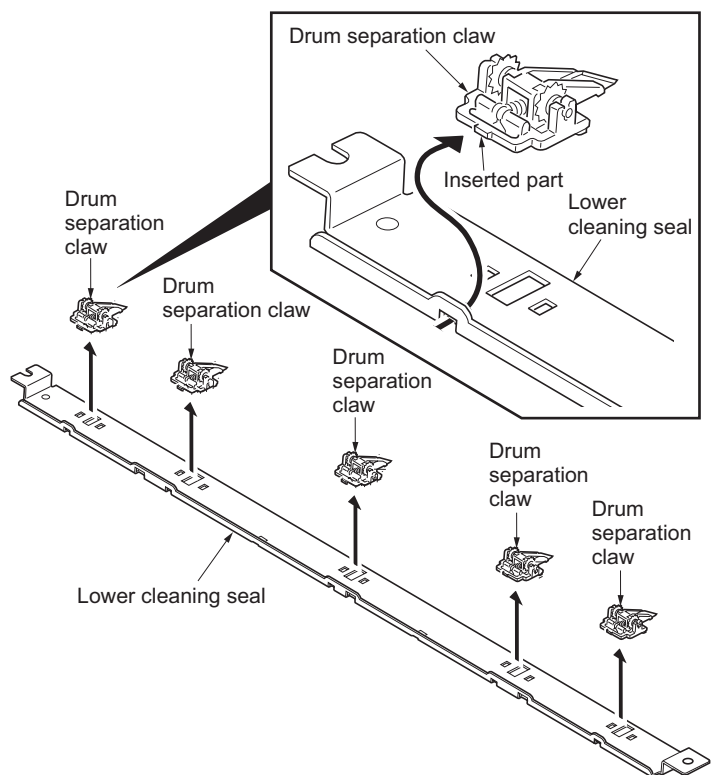

Figure 1-5-64

1-5-5 Developing section

(1) Detaching and refitting the developing unit

Follow the procedure below to replace the developing unit.

Procedure

1. Remove the drum unit (see page 1-5-34).
2. Remove two connectors.

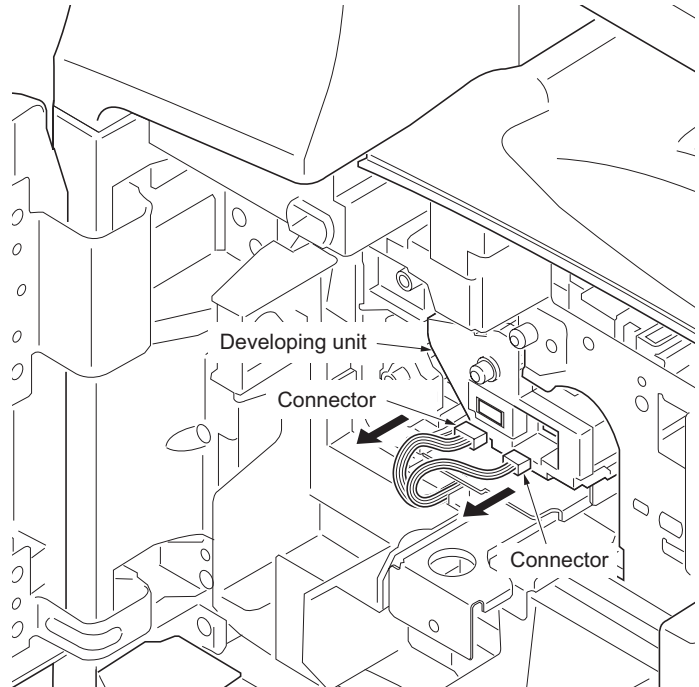

Figure 1-5-65

3. Remove the developing unit.
4. Replace the developing unit and install the unit.
5. Refit all the removed parts.
6. When the developing unit is replaced with a new one, carry out the following procedure.
7. Perform maintenance mode U130 (Initial setting for the developing unit) (see page 1-3-47).
8. Perform maintenance mode U410 (Adjusting the halftone automatically) (see page 1-3-75).

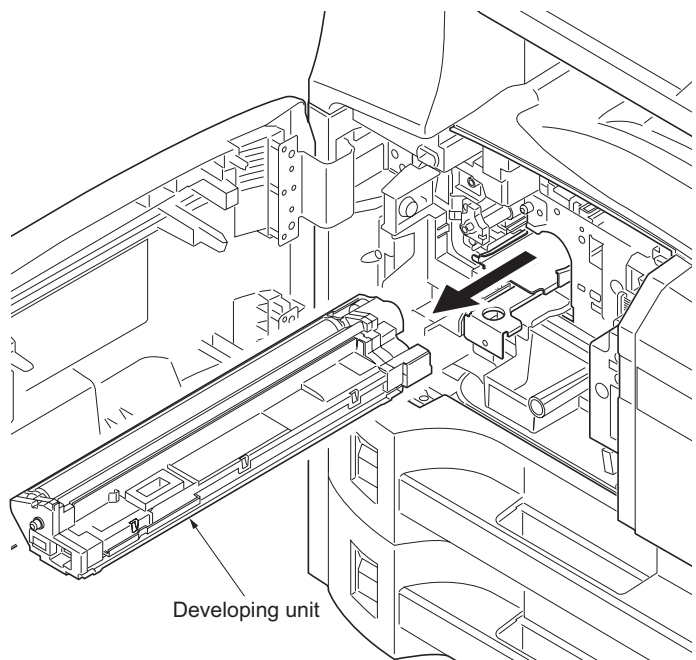

Figure 1-5-66

1-5-6 Transfer section

(1) Detaching and refitting the transfer roller unit

Follow the procedure below to replace the transfer roller unit.

Procedure

1. Open the left cover 1.
2. Unhook the hooks of the front and rear transfer bushes and remove the transfer roller unit.
3. Replace the transfer roller unit and install the unit.
The front and rear transfer springs must be firmly mounted on the holder.

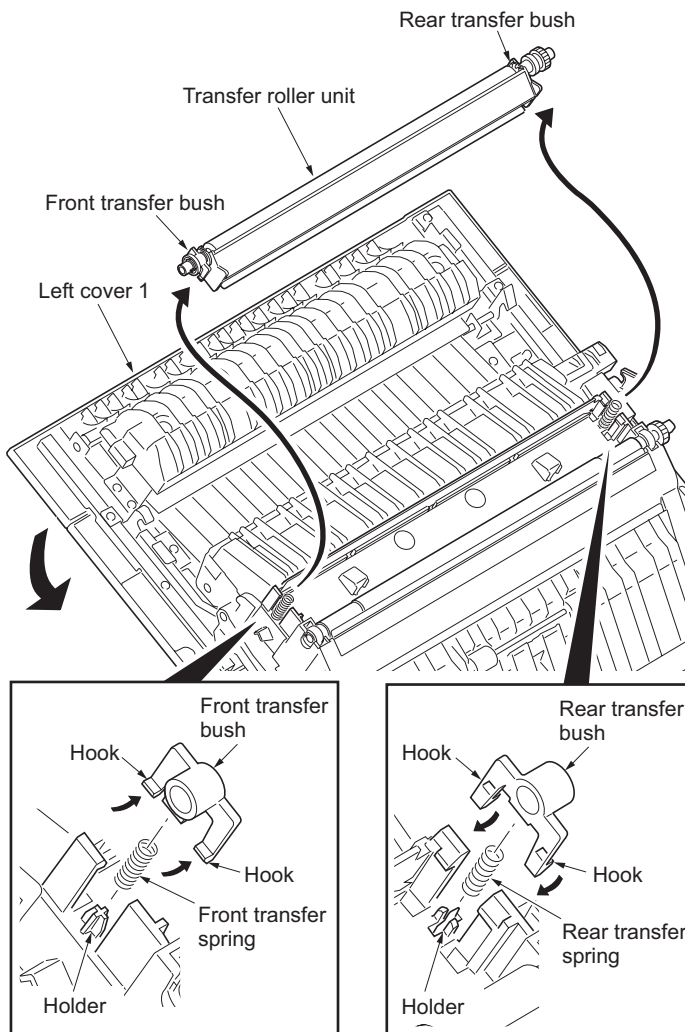

Figure 1-5-67

1-5-7 Fuser section

(1) Detaching and refitting the fuser unit

Follow the procedure below to check or replace the fuser unit.

Procedure

1. Open the front cover.
2. Remove the clip holder.
3. Remove two screws and remove front left cover.

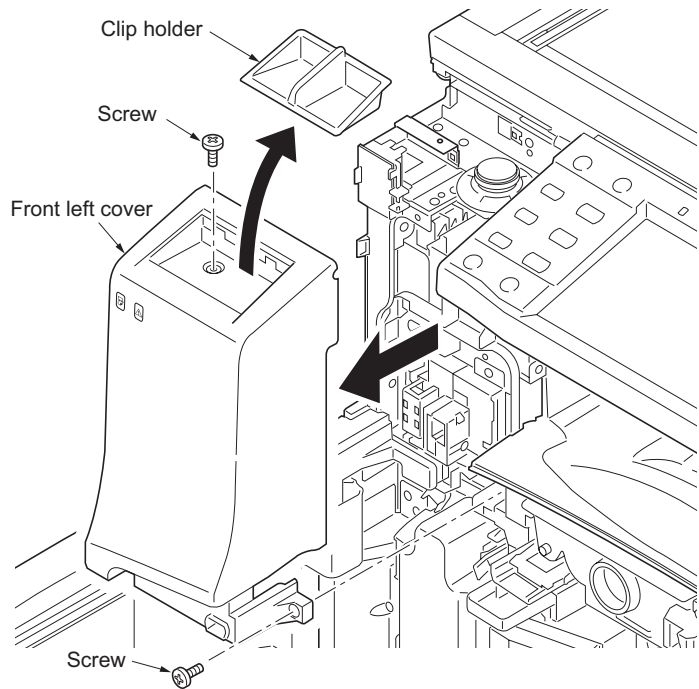

Figure 1-5-68

4. Open the left cover 1.
5. Remove two screws and remove the left cover hook.

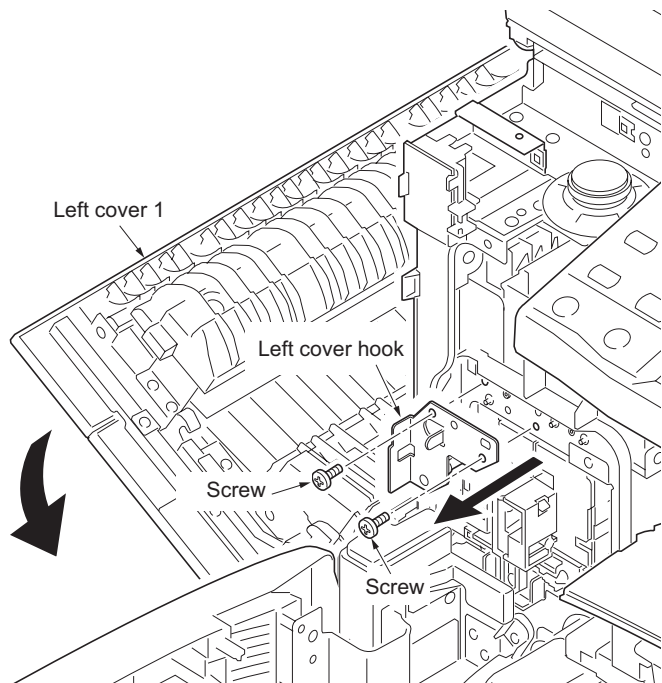

Figure 1-5-69

6. Remove the screw of the front left middle cover.

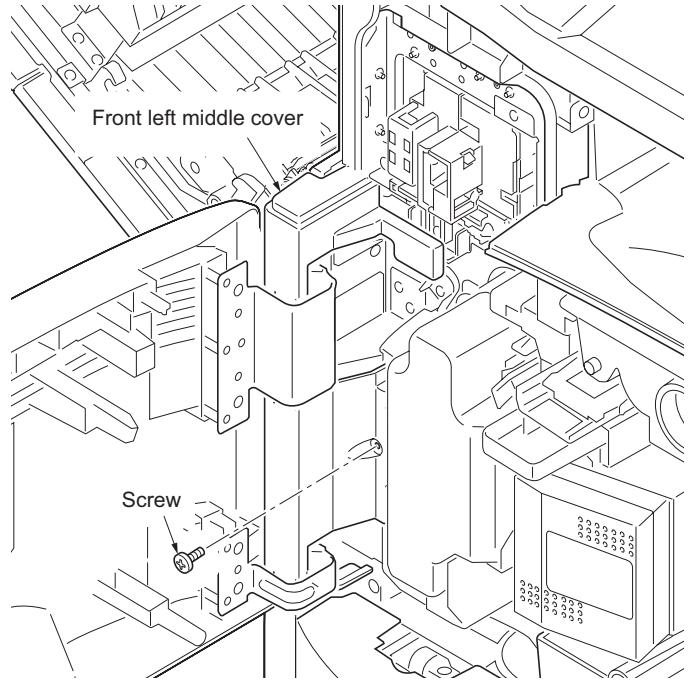

Figure 1-5-70

7. Remove the front left middle cover.

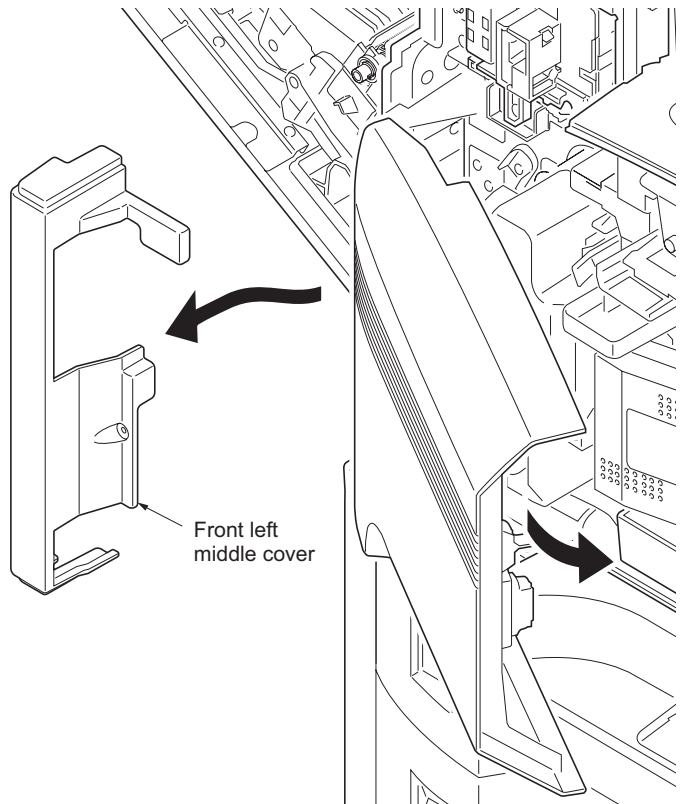

Figure 1-5-71

8. Remove three connectors.

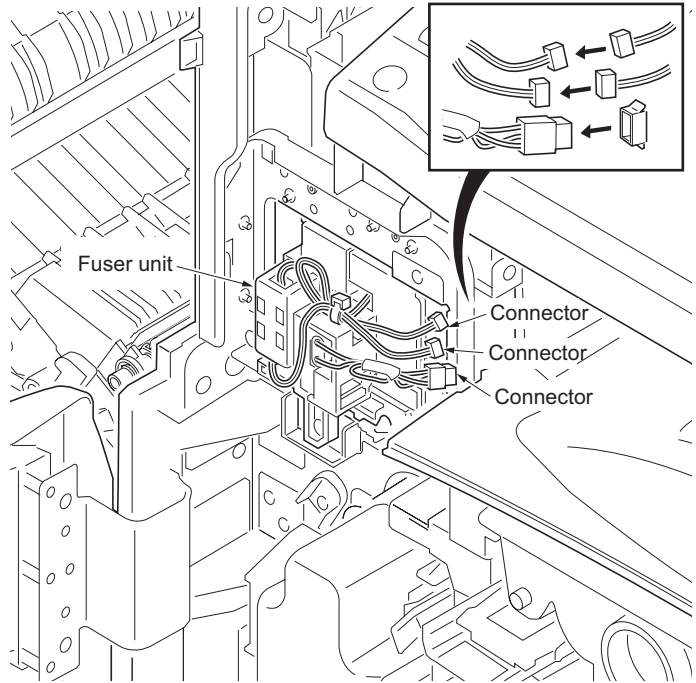

Figure 1-5-72

- 9. Remove the screw and remove the fuser unit.
- 10. Check or replace the fuser unit and install the unit.
- 11. Refit all the removed parts.

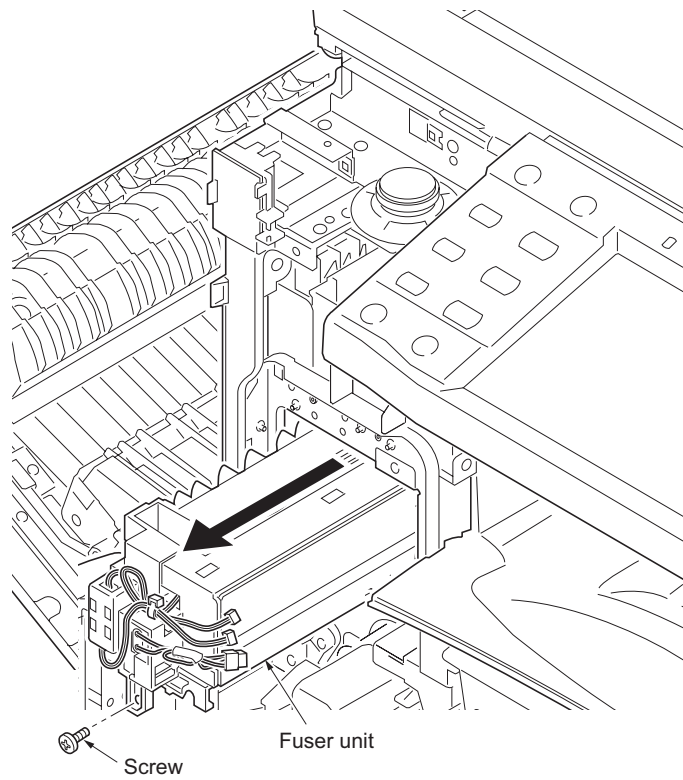

Figure 1-5-73

(2) Detaching and refitting the heat roller separation claws

Follow the procedure below to replace the heat roller separation claws.

Procedure

1. Remove the fuser heater (see page 1-5-43).
2. Remove four screws.
3. Unhook four hooks and remove the rear fuser guide.

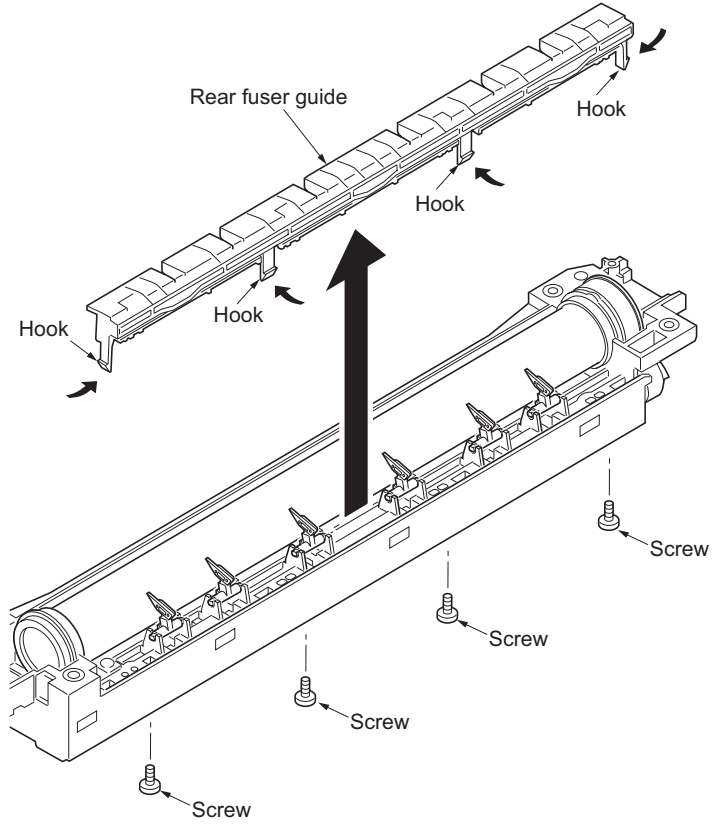

Figure 1-5-74

4. Remove the spring and remove the heat roller separation claws.
5. Replace the heat roller separation claws and install the claws.
6. Refit all the removed parts.

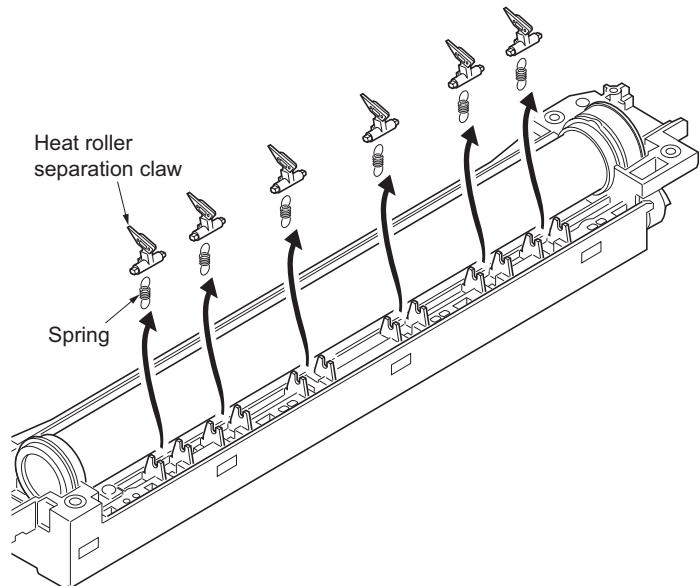

Figure 1-5-75

(3) Detaching and refitting the press roller

Follow the procedure below to replace the press roller.

Procedure

1. Remove the fuser unit (see page 1-5-37).
2. Unhook four hooks and remove the fuser unit cover.
3. Remove two connectors.

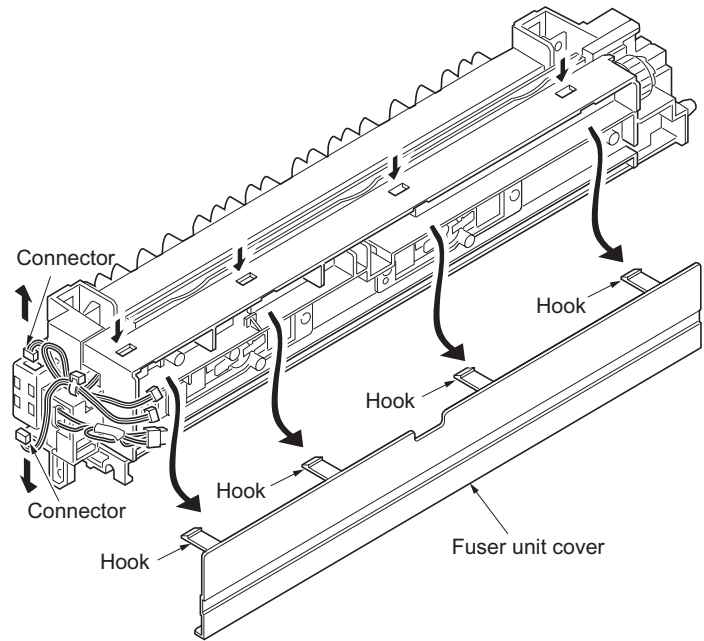

Figure 1-5-76

4. Remove four screws.
5. Separate the right fuser frame and left fuser frame.

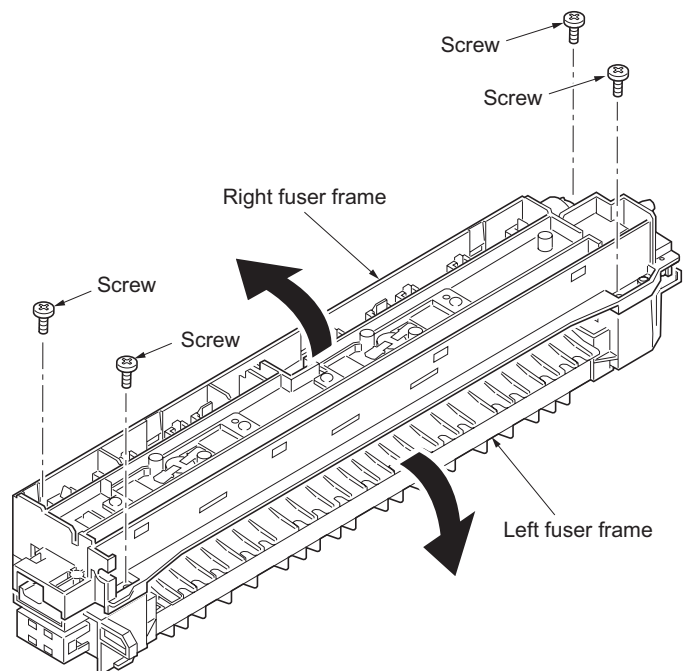

Figure 1-5-77

6. Remove the press roller.
7. Replace the press roller and install the roller.
8. Refit all the removed parts.

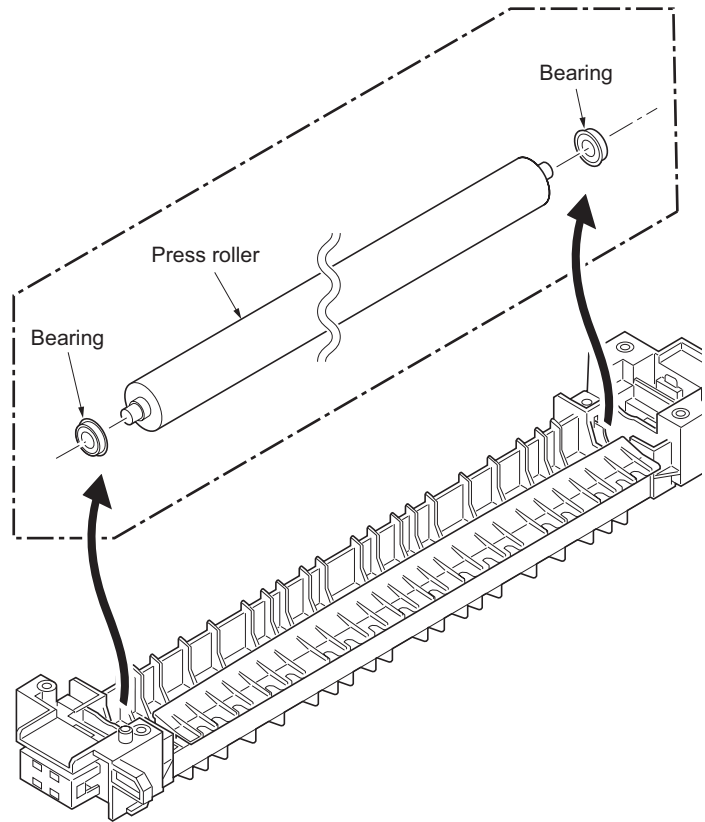

Figure 1-5-78

(4) Detaching and refitting the fuser heater

Follow the procedure below to replace the fuser heater.

Procedure

1. Remove the fuser unit (see page 1-5-37).
2. Unhook four hooks and remove the fuser unit cover.
3. Remove two connectors.

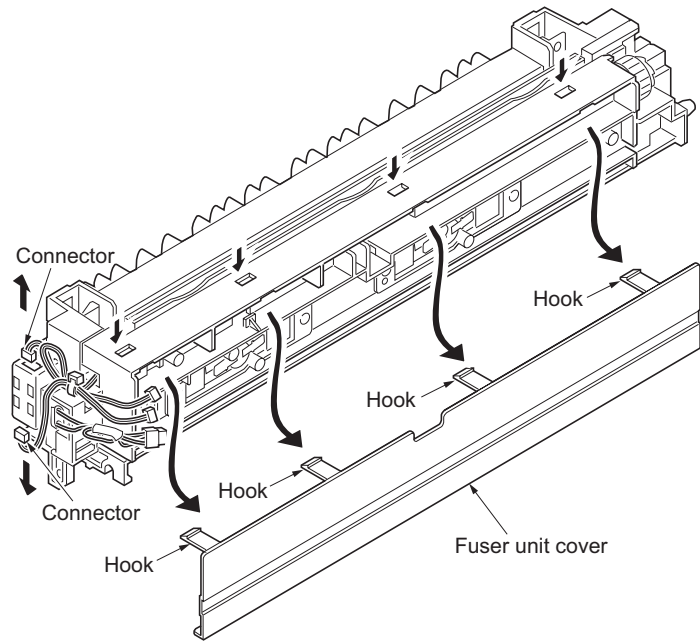

Figure 1-5-79

4. Remove four screws.
5. Separate the right fuser frame and left fuser frame.

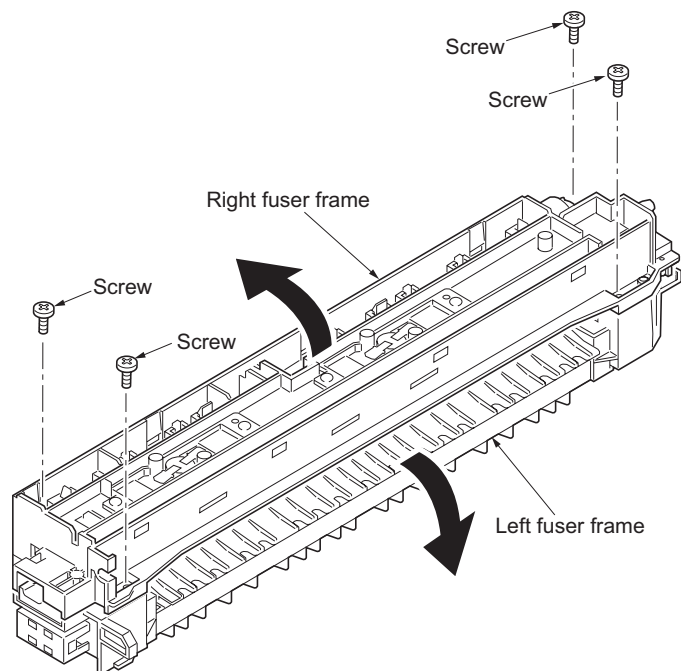

Figure 1-5-80

6. Remove two tabs.

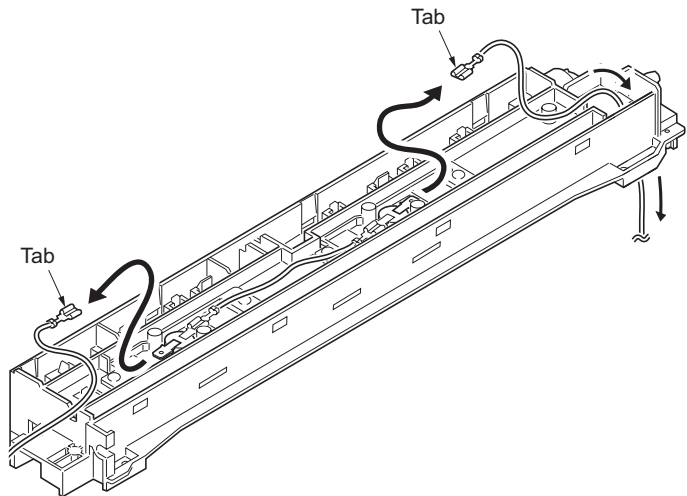

Figure 1-5-81

7. Remove the screw and rear fuser heater cover.
8. Remove the screw and front fuser heater cover.
9. Pull out the fuser heater.
10. Replace the fuser heater and install the heater.
11. Refit all the removed parts.

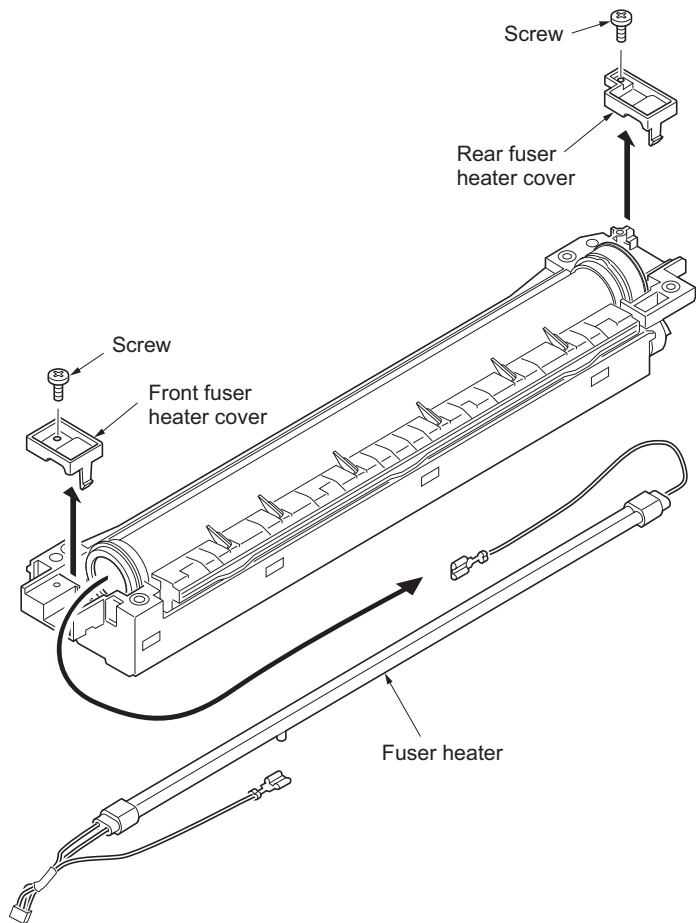

Figure 1-5-82

(5) Detaching and refitting the heat roller

Follow the procedure below to replace the heat roller.

Procedure

1. Remove the fuser heater (see page 1-5-43).
2. Remove the heat roller separation claws (see page 1-5-40).
3. Remove the front and rear heat bushes from right fuser frame.
4. Remove the fuser gear Z46, front and rear heat bushes from heat roller.
5. Replace the heat roller and install the roller
6. Refit all the removed parts.

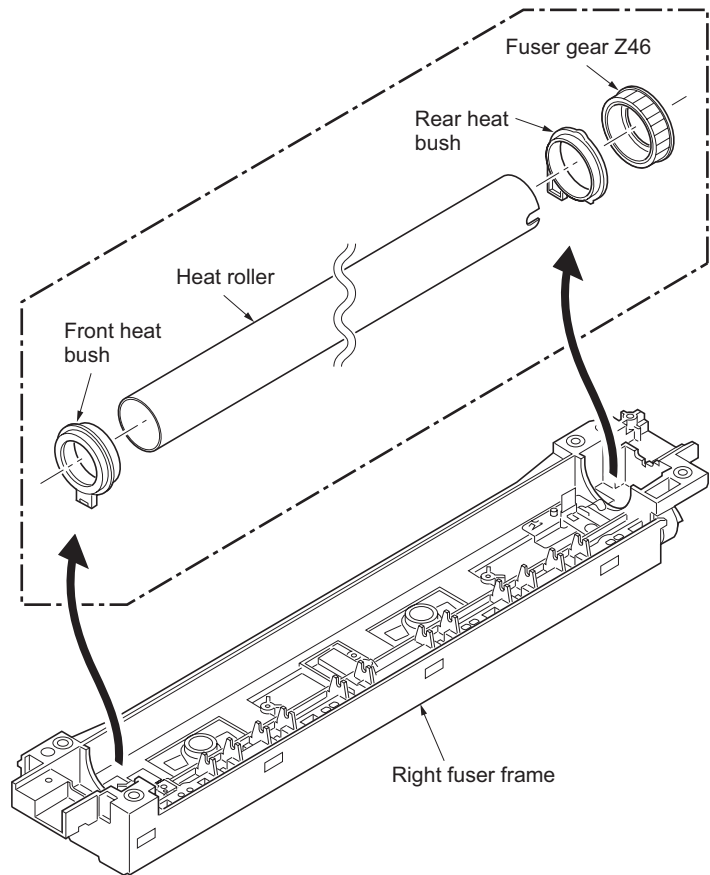

Figure 1-5-83

(6) Detaching and refitting the fuser thermistor 1

Follow the procedure below to replace the fuser thermistor 1.

Procedure

1. Remove the heat roller (see page 1-5-45).
2. Remove the screw and remove the fuser thermistor 1.
3. Replace the fuser thermistor 1 and install the thermistor.
4. Refit all the removed parts.

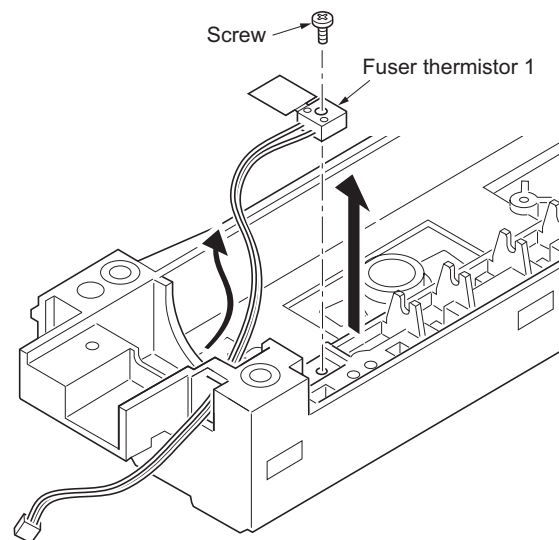

Figure 1-5-84

(7) Detaching and refitting the fuser thermistor 2

Follow the procedure below to replace the fuser thermistor 2.

Procedure

1. Remove the fuser unit (see page 1-5-37).
2. Unhook four hooks and remove the fuser unit cover.
3. Remove the connector.
4. Remove the band.

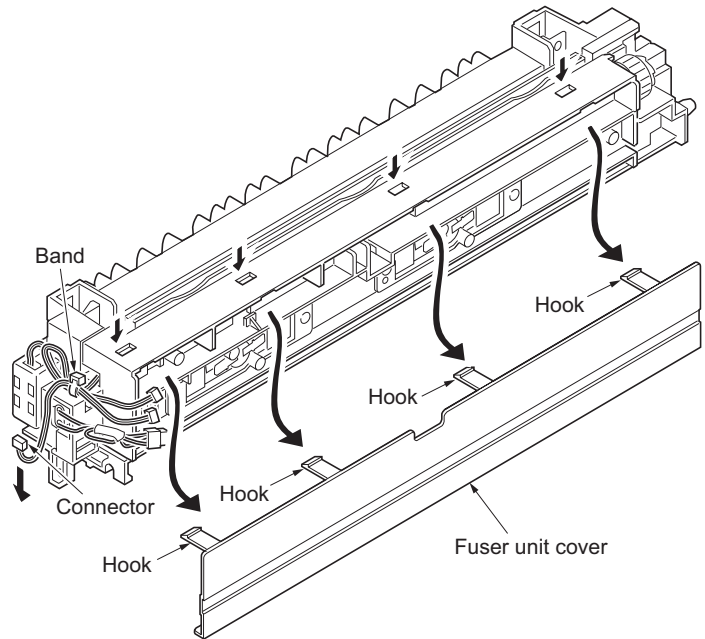

Figure 1-5-85

5. Remove the screw and remove the fuser thermistor 2.
6. Replace the fuser thermistor 2 and install the thermistor.
7. Refit all the removed parts.

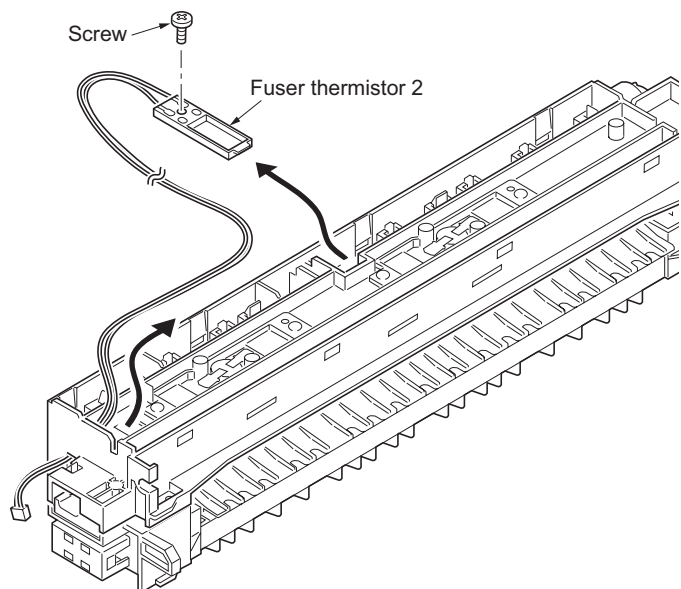

Figure 1-5-86

(8) Detaching and refitting the fuser thermostats 1 and 2

Follow the procedure below to replace the fuser thermostats 1 and 2.

Procedure

1. Remove the fuser unit (see page 1-5-37).
2. Unhook four hooks and remove the fuser unit cover.

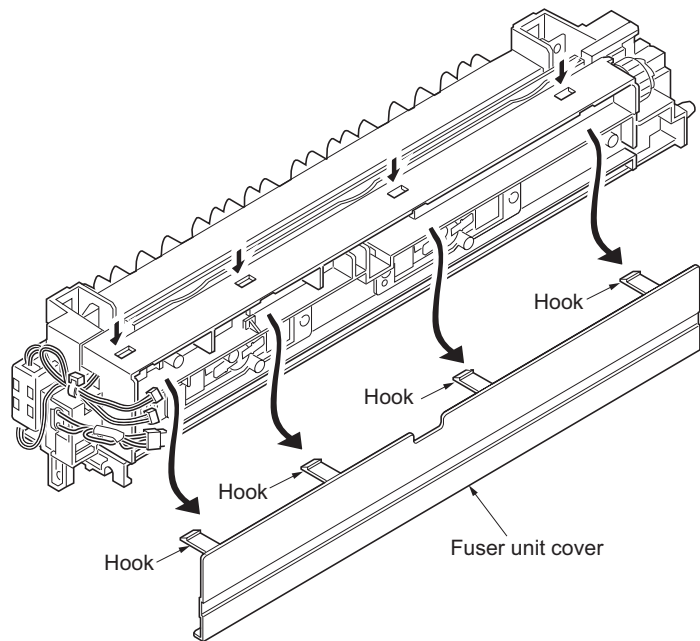

Figure 1-5-87

3. Remove four tabs.

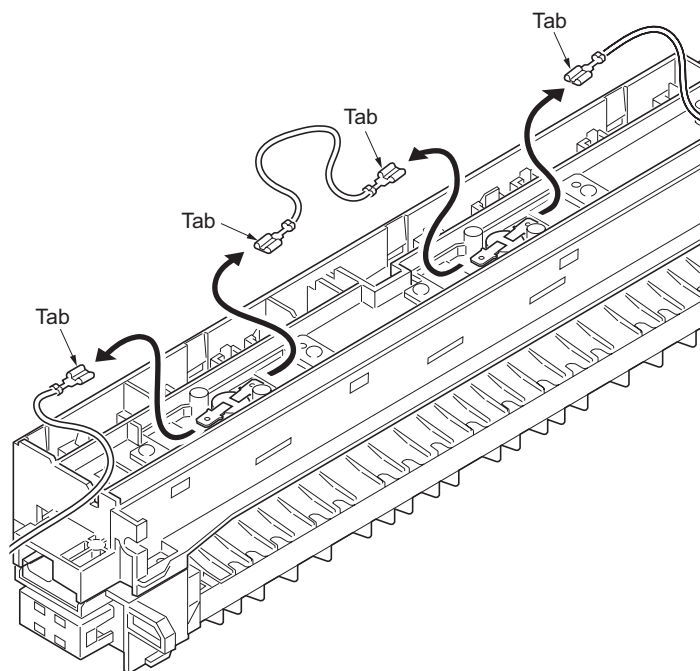

Figure 1-5-88

- Remove each two screws and remove two fuser thermostat holders.

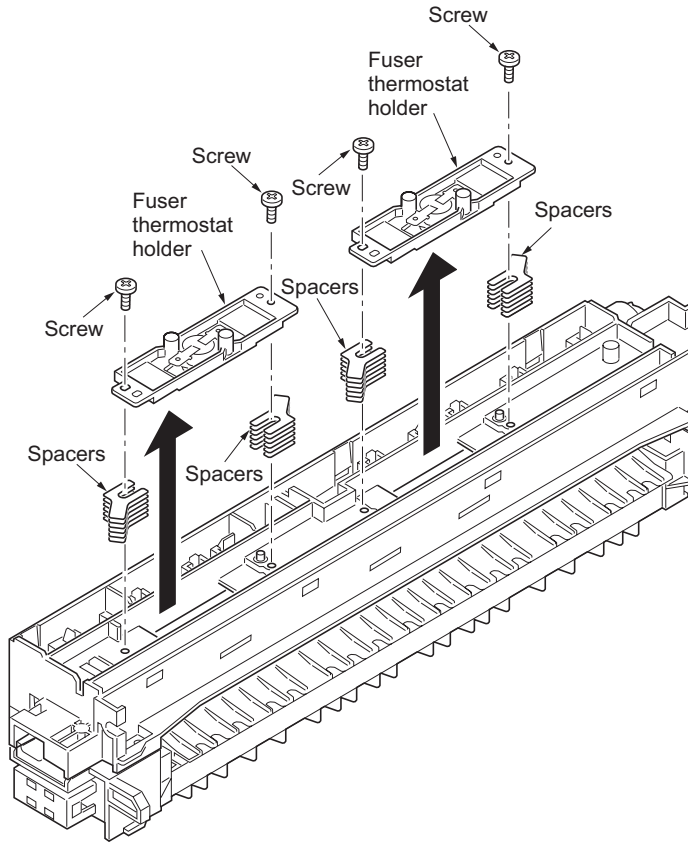

Figure 1-5-89

- Remove two screws and remove fuser thermostats 1 and 2.
- Replace the fuser thermostats 1 and 2 and install the thermostats.
- Refit all the removed parts.

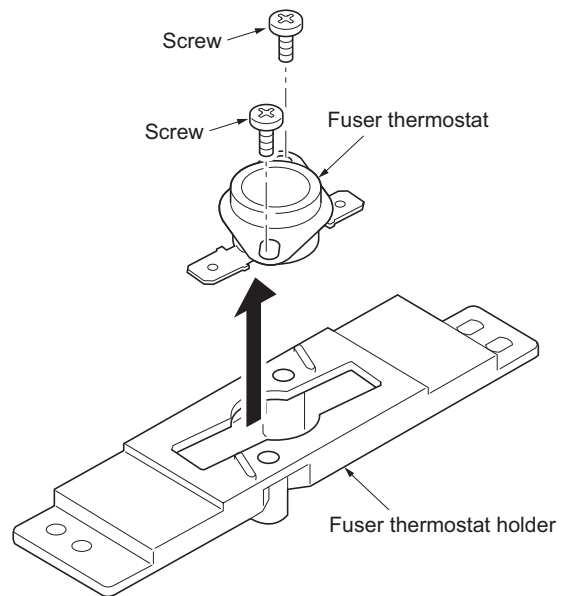

Figure 1-5-90

(9) Adjusting front position of the fuser unit (adjusting lateral squareness)

Follow the procedure below if the drum is not parallel to the fuser unit and therefore paper is not fed straight to the fuser section and the trailing edge of image on either the front or rear side becomes longer.

Procedure

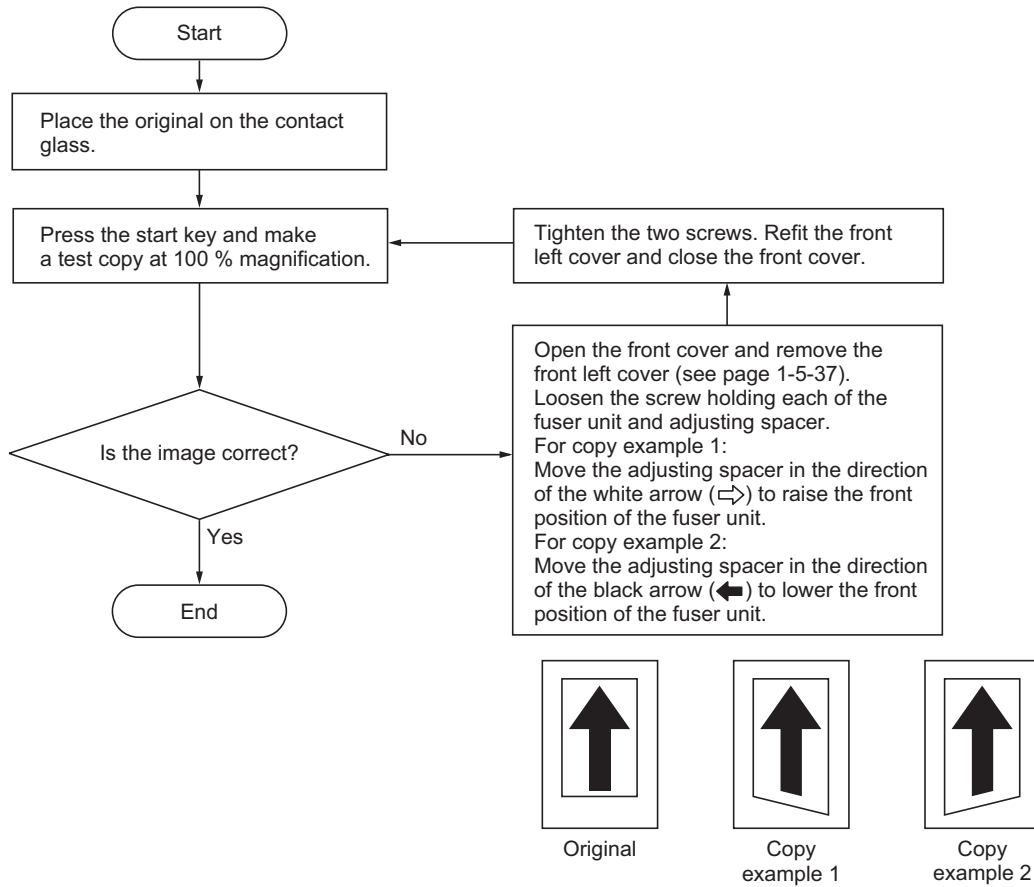

Figure 1-5-91

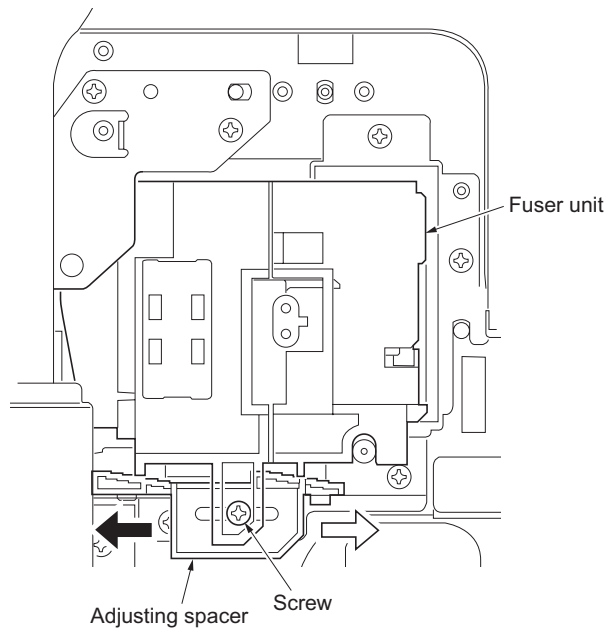

Figure 1-5-92

1-5-8 Others

(1) Detaching and refitting the ozone filter 1

Follow the procedure below to replace the ozone filter 1.

Procedure

1. Open the filter cover.
2. Remove the ozone filter 1.
3. Replace the ozone filter 1 and install the filter cover.

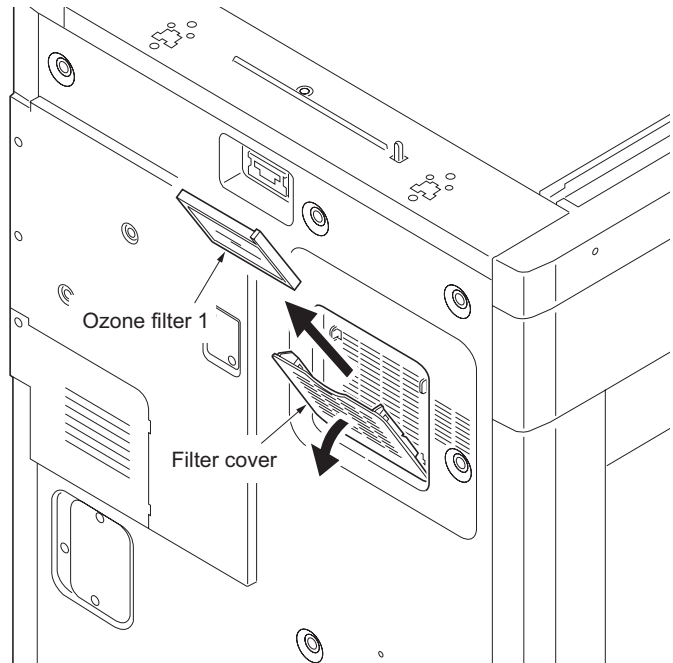

Figure 1-5-93

(2) Detaching and refitting the ozone filter 2

Follow the procedure below to replace the ozone filter 2.

Procedure

1. Remove the filter cover.
2. Remove the ozone filter 2.
3. Replace the ozone filter 2 and install the filter.
4. Refit all the removed parts.

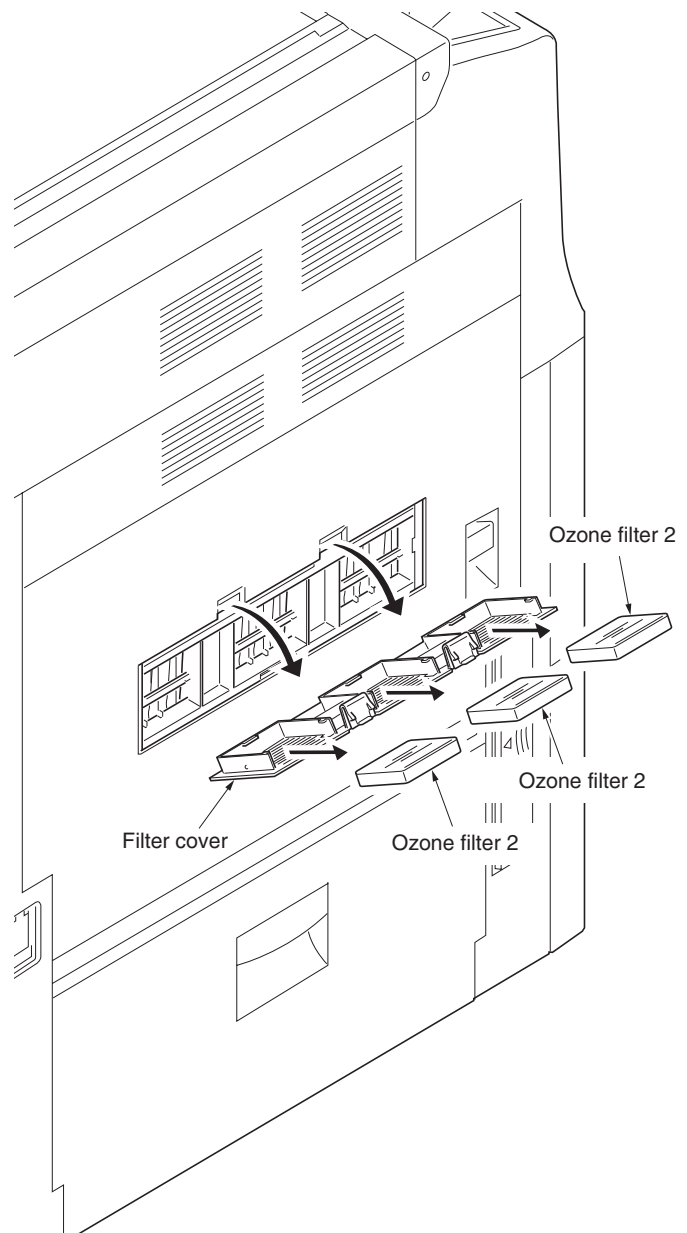

Figure 1-5-94

(3) Detaching and refitting the hard disk

Follow the procedure below to replace the hard disk.

Procedure

1. Remove eleven screws and remove the rear cover.

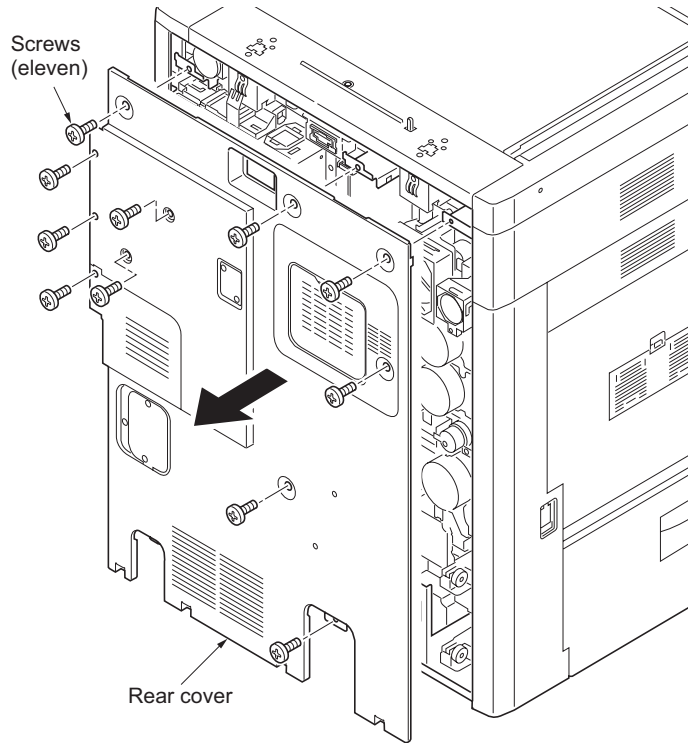

Figure 1-5-95

2. Pressing the lock lever and remove two connectors.

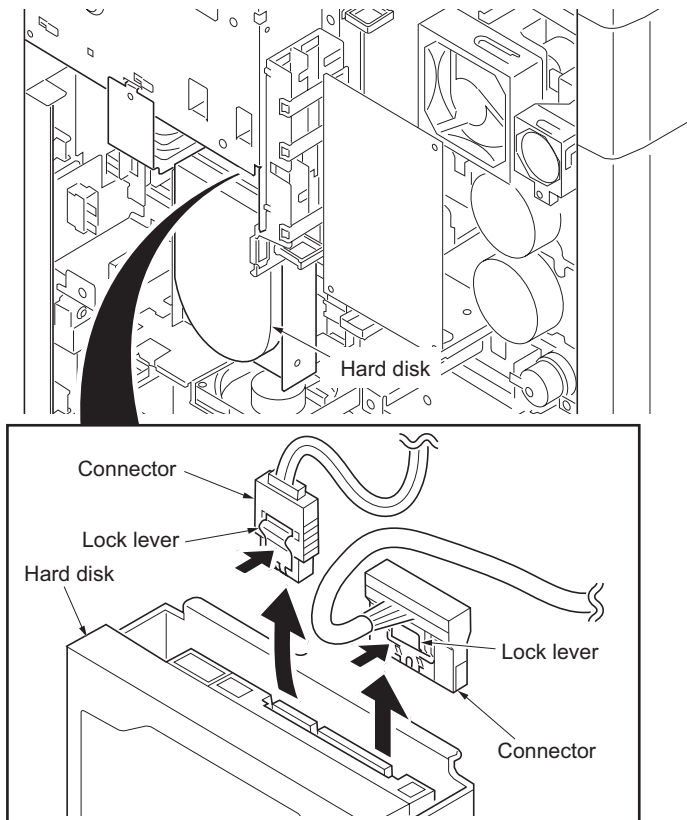

Figure 1-5-96

3. Remove three screws and remove the HDD mount.

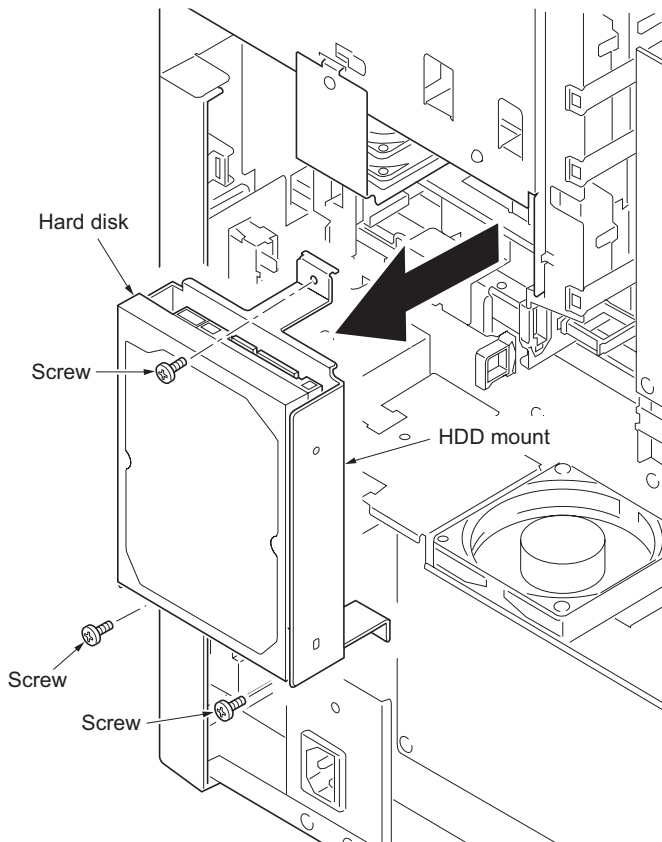

Figure 1-5-97

4. Remove four screws and remove the HDD mount.
5. Replace the hard disk and Install the hard disk.
6. Refit all the removed parts.
7. When the hard disk is replaced, perform maintenance mode U024 to initialize the hard disk (see page 1-3-19).

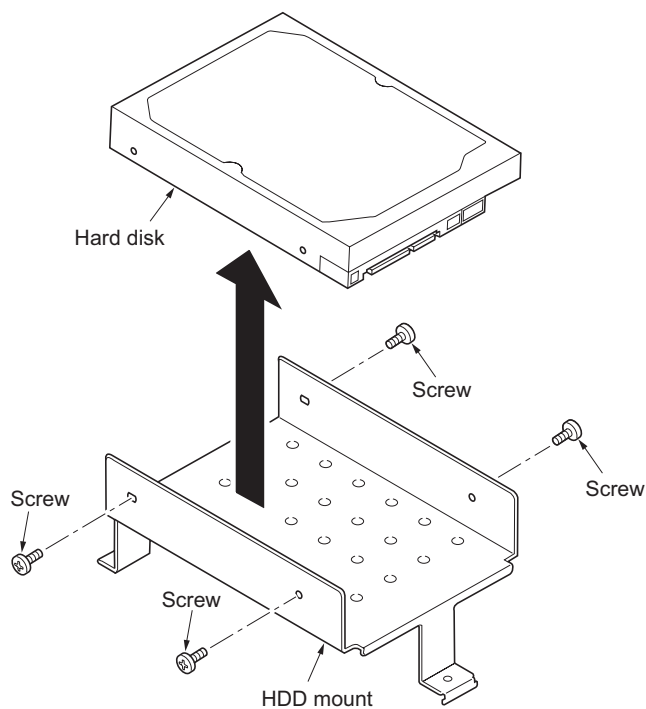

Figure 1-5-98

(4) Direction of installing the principal fan motors

When detaching or refitting the fan motors, be careful of the airflow direction (intake or exhaust).

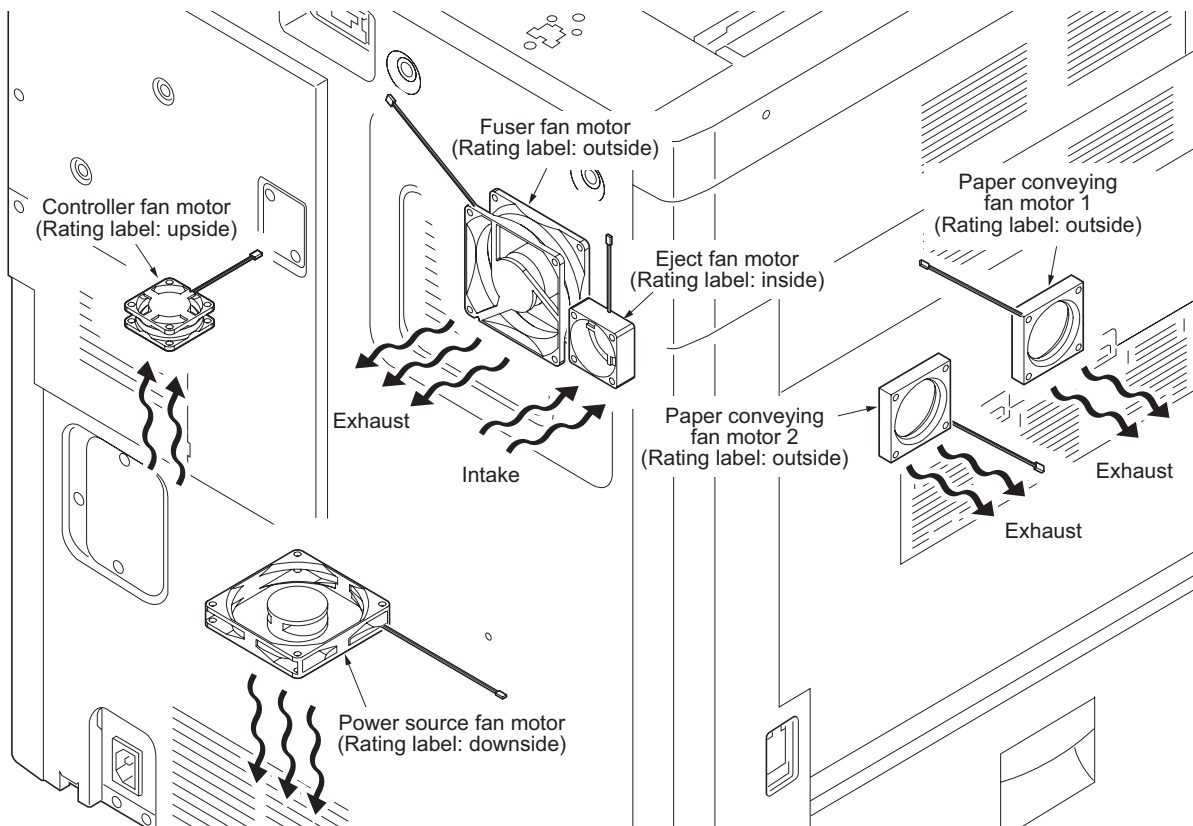
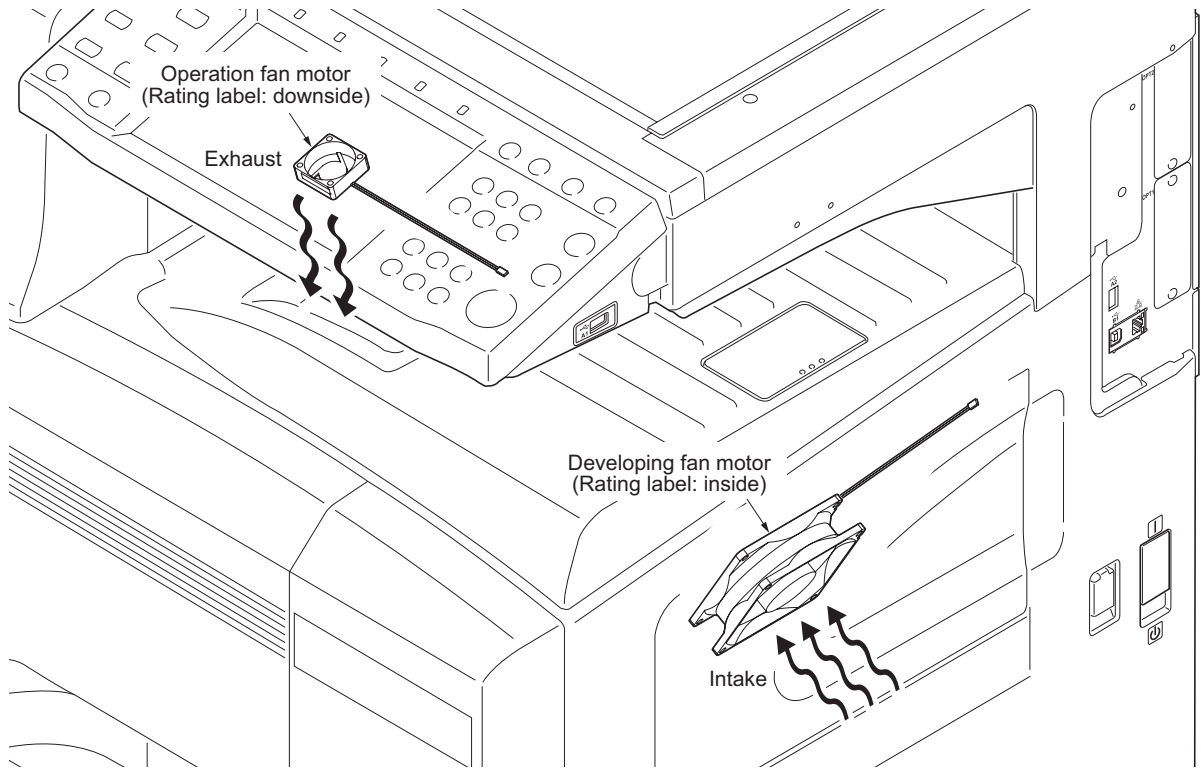

Figure 1-5-99

This page is intentionally left blank.

1-6-1 Upgrading the firmware

Follow the procedure below to upgrade the firmware of main PWB, engine PWB and MMI.

Firmware upgrading requires the following tools:

USB memory

Procedure

1. Perform maintenance item U000 (maintenance report output) and check U019 ROM version.
2. Press the power key on the operation panel to off. Make sure that the power indicator and the memory indicator are off before turning off the main power switch. And then unplug the power cable from the wall outlet.
3. Insert the USB memory in the USB memory slot.
4. Insert the power plug and turn the main power switch on. Upgrading firmware starts.

Caution:

Never turn the main power switch off during upgrading.

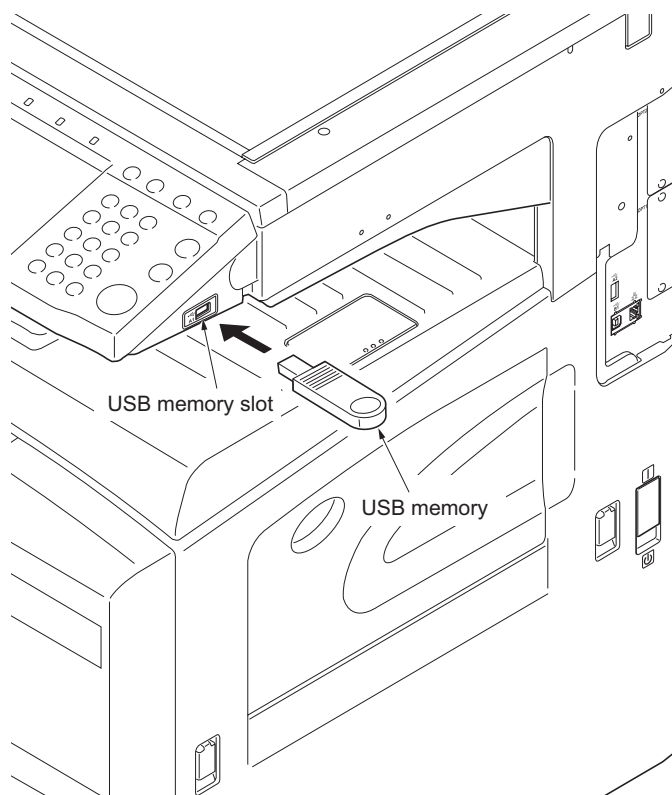

Figure 1-6-1

5. [100% Completed] is displayed on the touch panel when upgrading is complete.
6. Turn the main power switch off and unplug the power cable from the wall outlet.
7. Remove the USB memory from the USB memory slot.
8. Insert the power plug and turn the main power switch on.

1-6-2 Adjustment-free variable resistors (VR)

The variable resistors listed below are set at the factory prior to shipping and cannot be adjusted in the field.

High voltage PWB: VR101, VR201, VR302, VR303

Power source PWB: VR351

APC PWB: VR1

Inverter PWB: VR31

1-6-3 Remarks on main and engine PWB replacement

When replacing the main or engine PWB, remove the EEPROM from the PWB that has been removed and then reattach it to the new PWB.

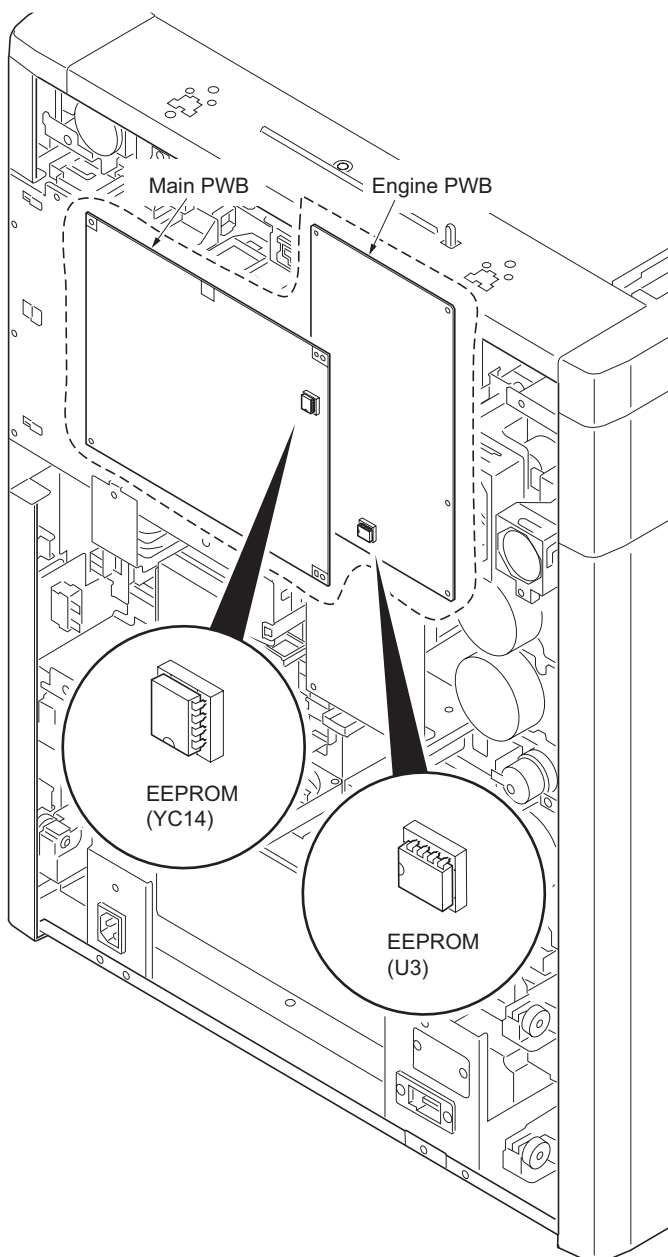

Figure 1-6-2

2-1-1 Paper feed section

(1) Cassette paper feed section

The paper feed section consists of the primary feed and secondary feed subsections. Primary feed conveys paper from the cassettes 1, 2 or MP tray to the left and right registration rollers, at which point secondary feed takes place and the paper travels to the transfer section in sync with the printing timing.

Each cassette consists of a lift driven by the lift motor and other components. Each cassette can hold up to 500 sheets of paper. Paper is fed from the cassette by the rotation of the forwarding pulley and paper feed pulley. The separation pulley prevents multiple sheets from being fed at one time, via the torque limiter.

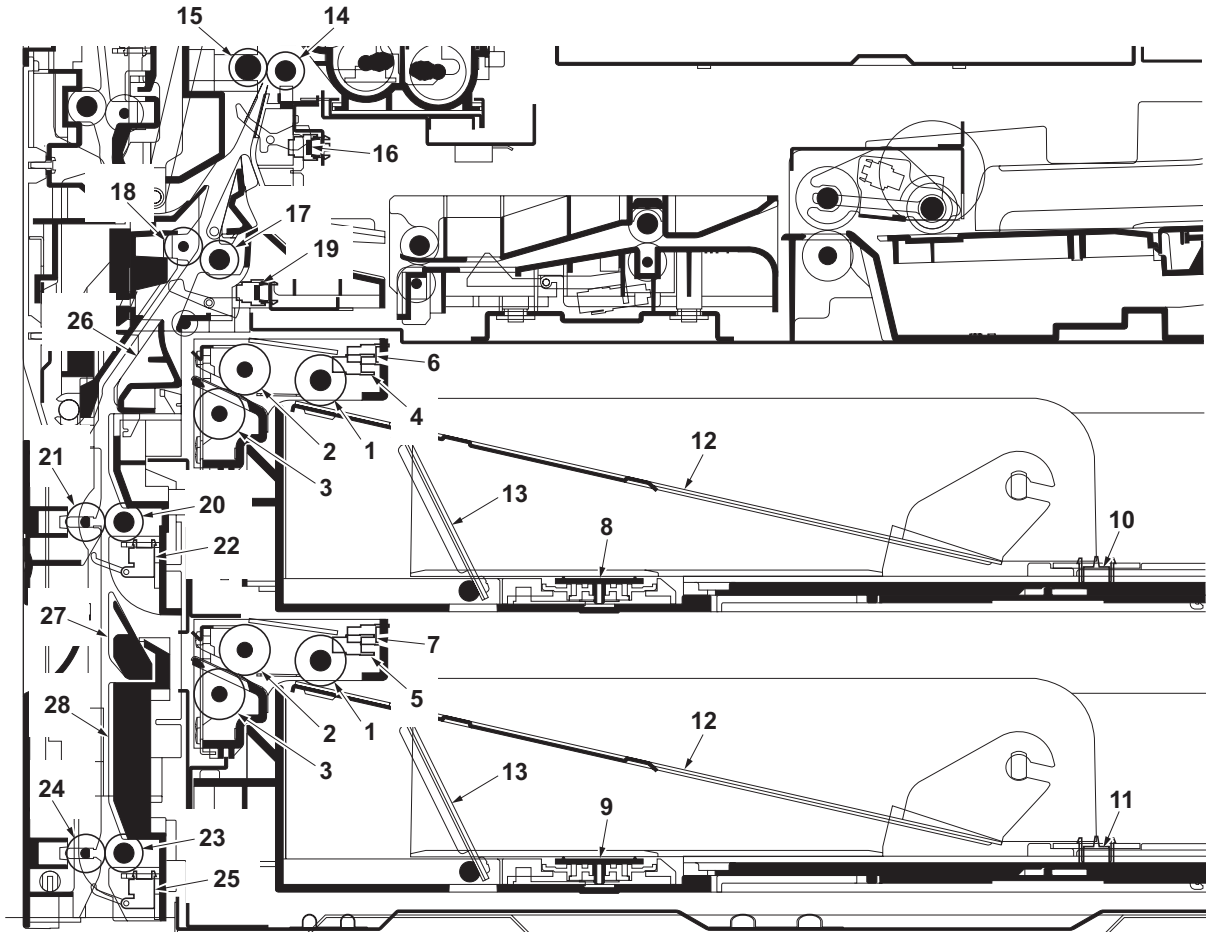

Figure 2-1-1 Cassette paper feed section

- | | |
|---|-------------------------------------|
| (1) Forwarding pulley | (15) Left registration roller |
| (2) Paper feed pulley | (16) Registration switch (RSW) |
| (3) Separation pulley | (17) Feed roller 1 |
| (4) Paper switch 1 (PSW1) | (18) Feed pulley |
| (5) Paper switch 2 (PSW2) | (19) Feed switch 1 (FSW1) |
| (6) Lift switch 1 (LSW1) | (20) Feed roller 2 |
| (7) Lift switch 2 (LSW2) | (21) Feed pulley |
| (8) Paper size width switch 1 (PWSW1) | (22) Feed switch 2 (FSW2) |
| (9) Paper size width switch 2 (PWSW2) | (23) Feed roller 3 |
| (10) Paper size length switch 1 (PLSW1) | (24) Feed pulley |
| (11) Paper size length switch 2 (PLSW2) | (25) Feed switch 3 (FSW3) |
| (12) Cassette bases | (26) Vertical paper conveying guide |
| (13) Lift operation plates | (27) Paper conveying guide |
| (14) Right registration roller | (28) Vertical paper conveying frame |

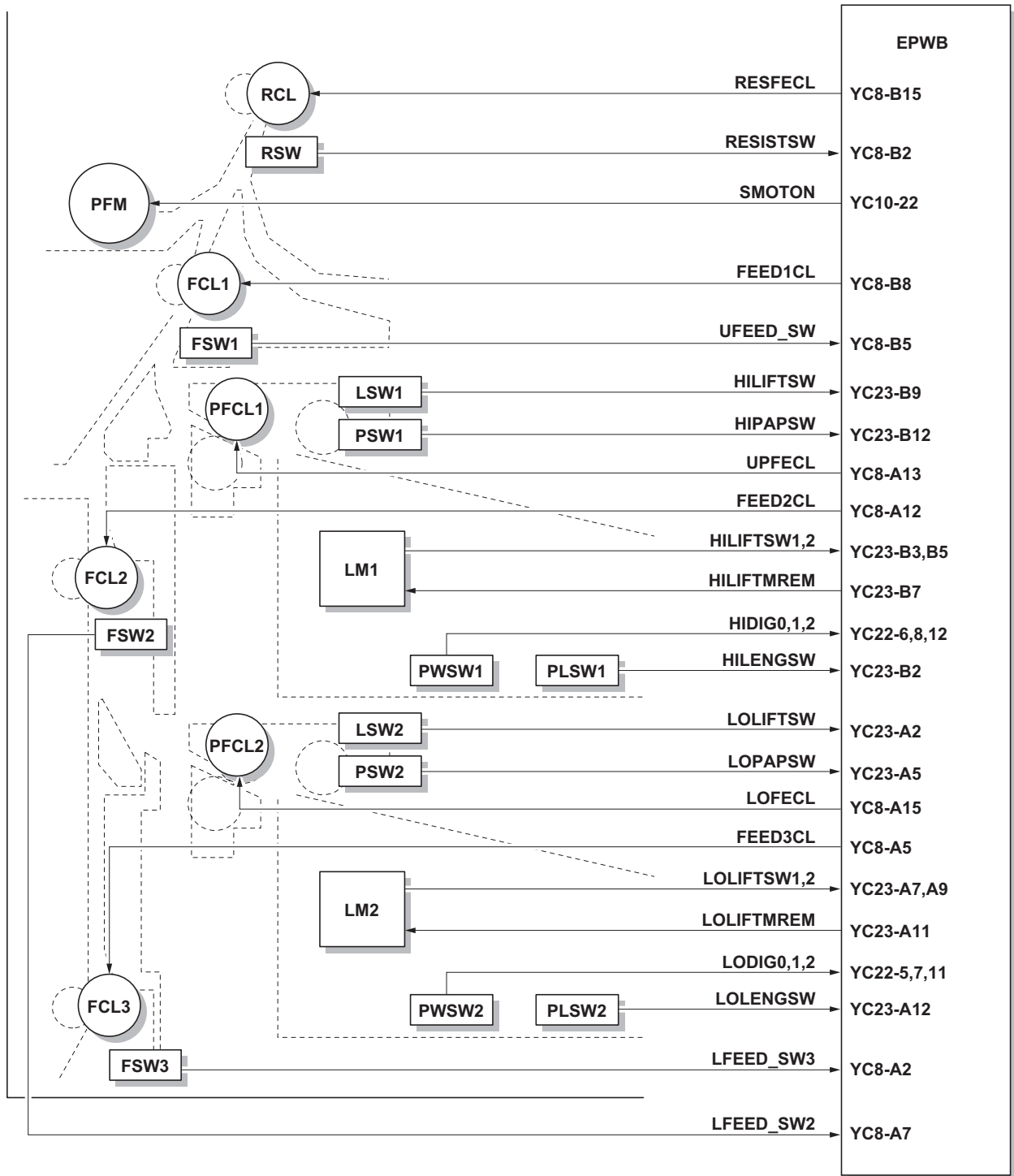

Figure 2-1-2 Cassette paper feed section block diagram

(2) MP tray paper feed section

The MP tray can hold up to 200 sheets of paper at one time. Paper is fed from the MP tray by the rotation of the MP forwarding pulley and MP paper feed pulley. Also during paper feed, the MP separation pulley prevents multiple sheets from being fed at one time by the torque limiter.

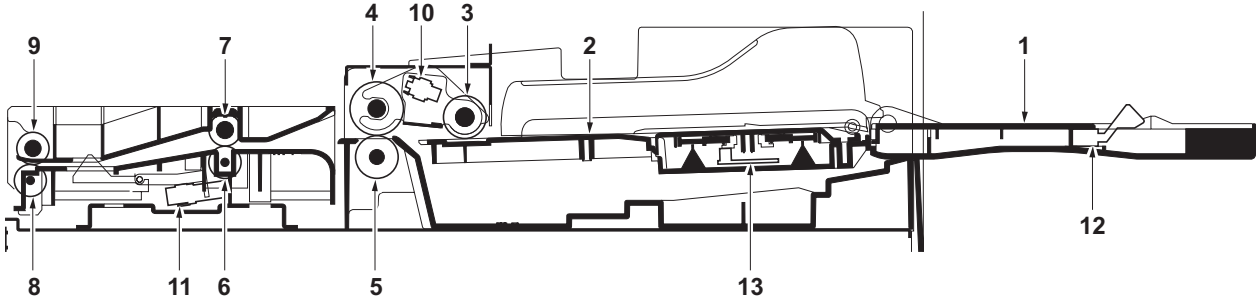

Figure 2-1-3 MP tray paper feed section

- | | |
|--------------------------|---|
| (1) MP tray | (9) MP feed roller 2 |
| (2) MP lift plate | (10) MP paper switch (MPPSW) |
| (3) MP forwarding pulley | (11) MP feed switch (MPFSW) |
| (4) MP paper feed pulley | (12) MP paper size length switch (MPPLSW) |
| (5) MP separation pulley | (13) MP paper size width switch (MPPWSW) |
| (6) MP feed pulley | |
| (7) MP feed roller 1 | |
| (8) MP feed pulley | |

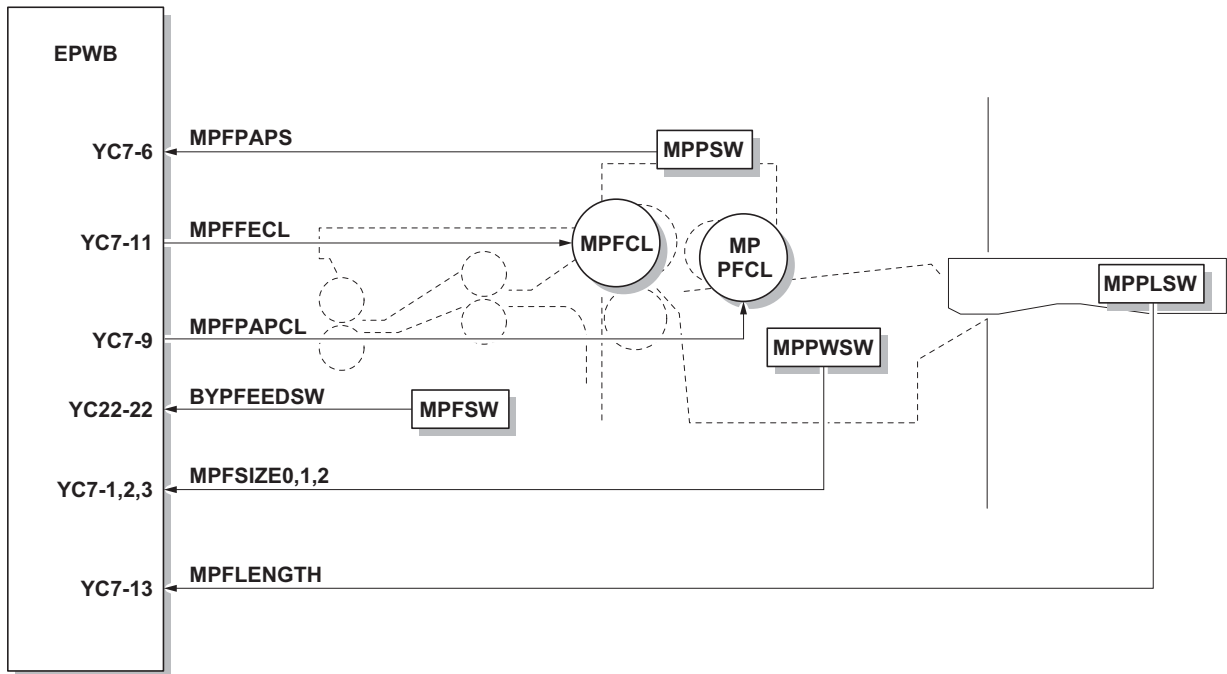

Figure 2-1-4 MP tray paper feed section block diagram

2-1-2 Main charging section

The main charging section consists of the main charger assembly, drum and so on. The drum is electrically charged uniformly by means of a grid to form a latent image on the surface. The main charger unit charges the drum so that a latent image is formed on the surface, the shield grid ensuring the charge is applied uniformly.

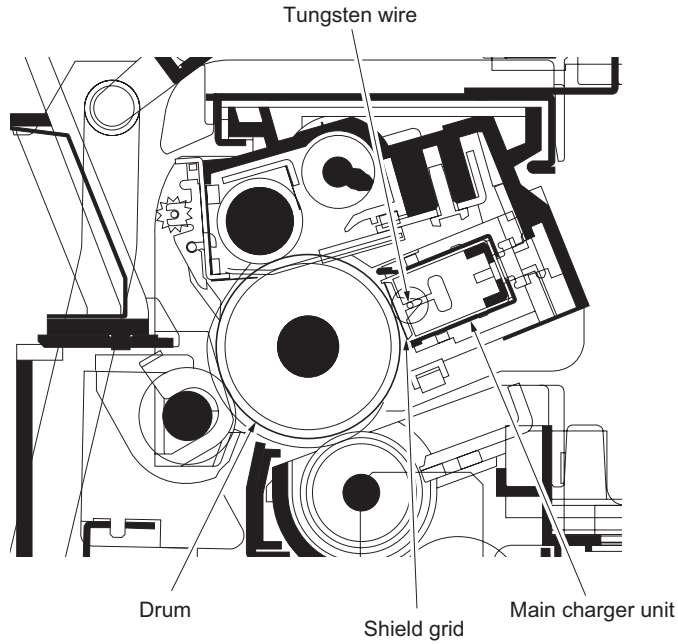

Figure 2-1-5 Main charging section

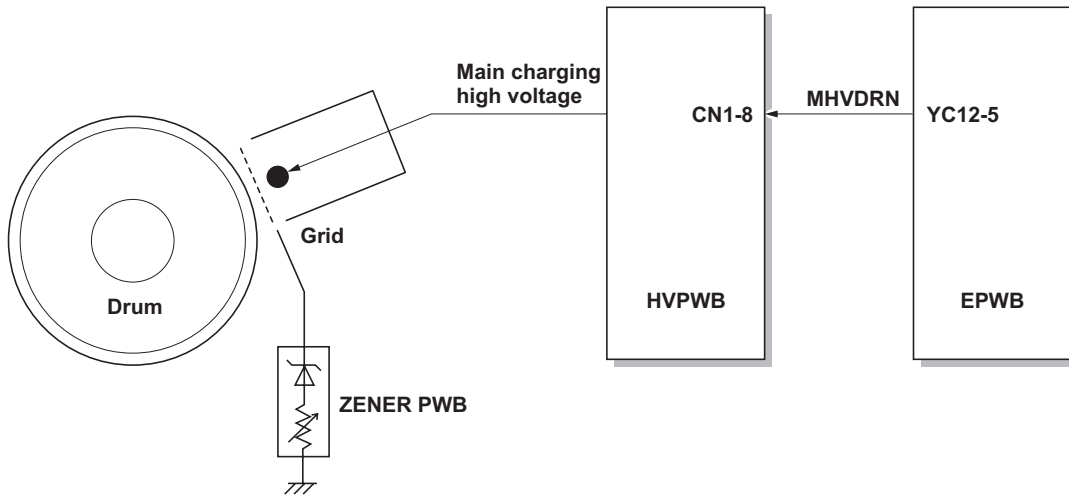

Figure 2-1-6 Main charging section block diagram

2-1-3 Optical section

The optical section consists of the image scanner section for scanning and the laser scanner section for printing.

(1) Image scanner section

The original image is illuminated by the exposure lamp (EL) and scanned by the CCD PWB (CCDPWB) in the image scanning unit via the three mirrors, the reflected light being converted to an electrical signal.

The scanner and mirror frames travel to scan on the optical rails on the front and rear of the machine to scan from side to side. The speed of the mirror frames is half the speed of the scanner.

When the DP is used, the scanner and mirror frames stop at the DP original scanning position to start scanning.

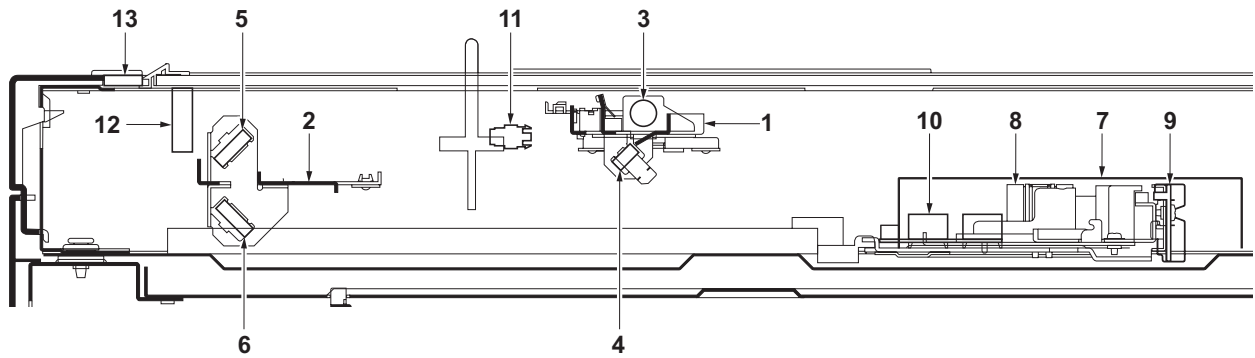

Figure 2-1-7 Image scanner section

- (1) Mirror 1 frame
- (2) Mirror 2 frame
- (3) Exposure lamp (EL)
- (4) Mirror 1
- (5) Mirror 2
- (6) Mirror 3
- (7) ISU
- (8) Lens
- (9) CCD PWB (CCDPWB)
- (10) Original size sensor (OSS)
- (11) Original detection switch (ODSW)
- (12) Home position switch (HPSW)
- (13) Slit glass

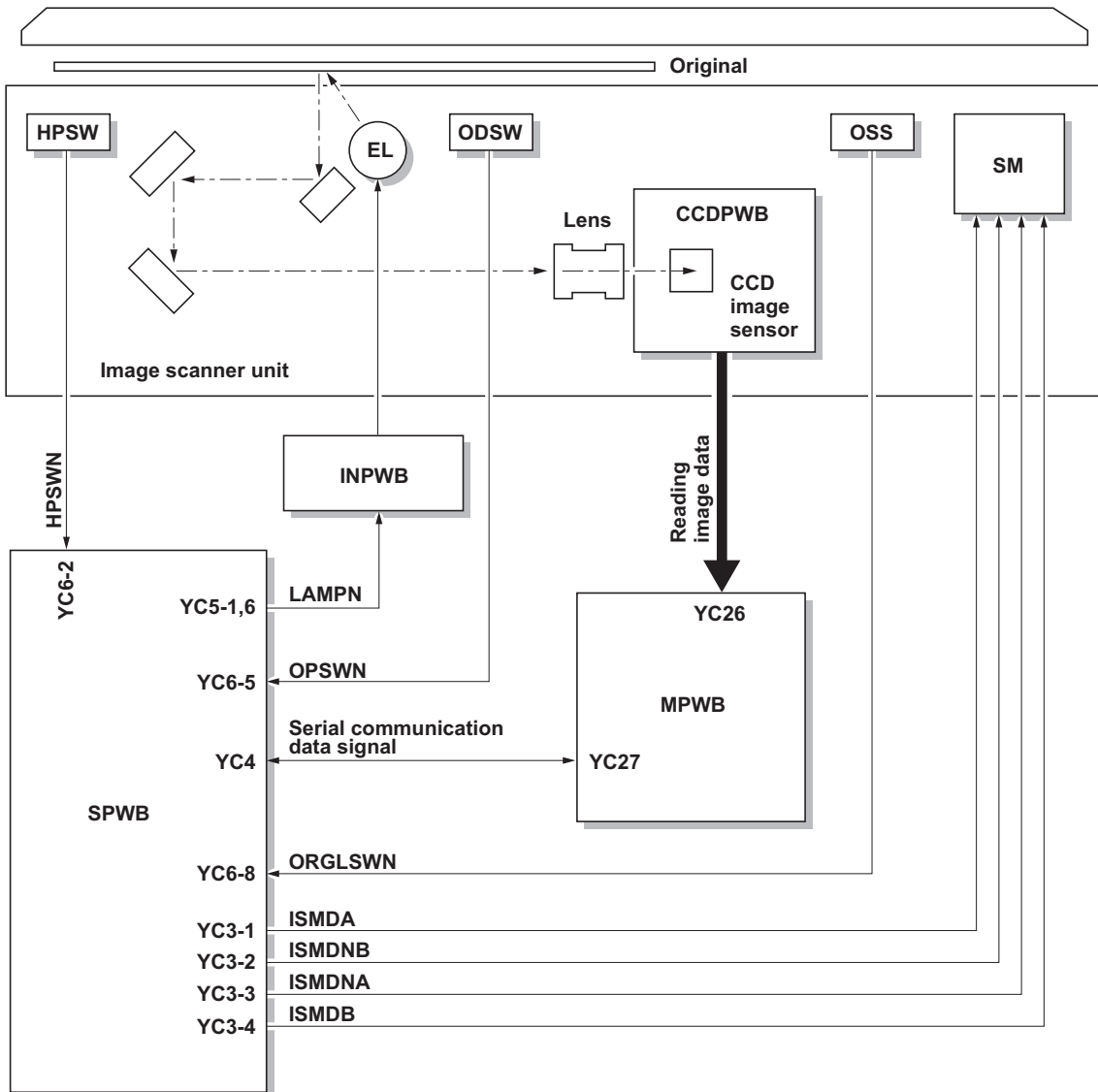

Figure 2-1-8 Image scanner section block diagram

(2) Laser scanner section

The image data scanned by the CCD PWB (CCDPWB) is processed on the main PWB (MPWB) and transmitted as image printing data to the laser scanner unit (LSU). By repeatedly turning the laser on and off, the laser scanner unit forms a latent image on the drum surface.

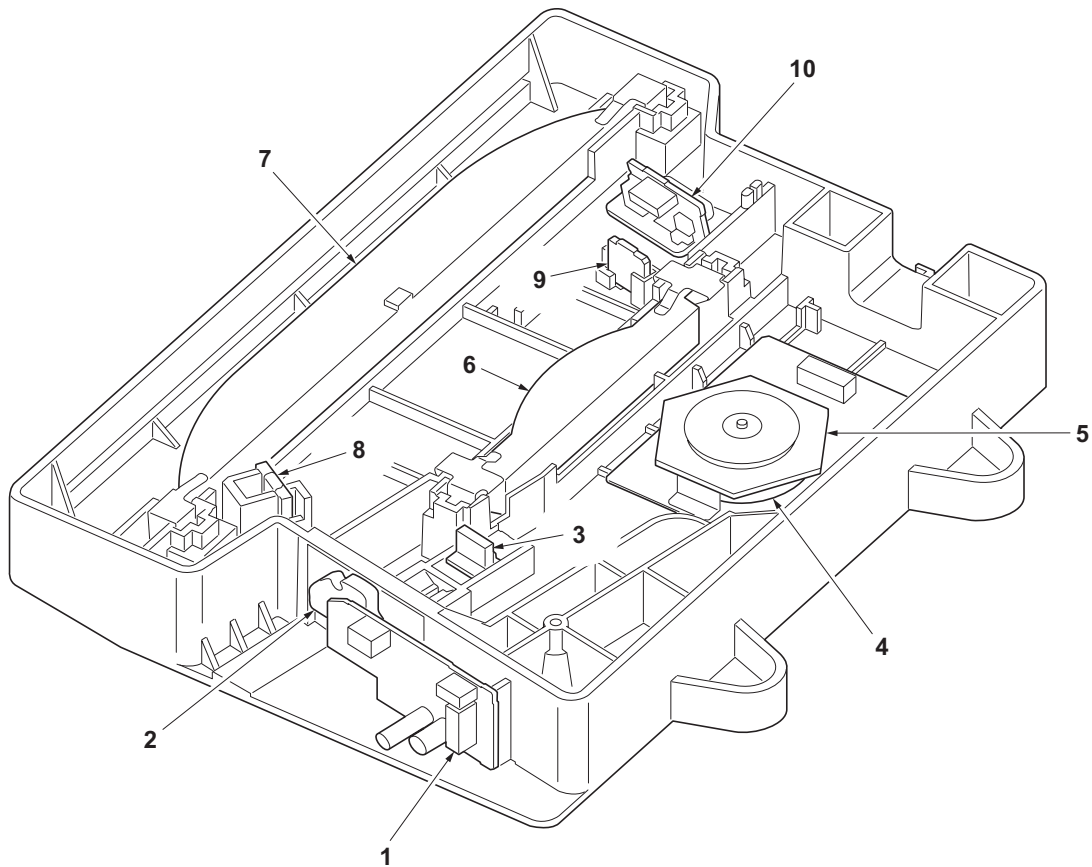

Figure 2-1-9 Laser scanner section

- (1) APC PWB (APCPWB)
- (2) Laser diode
- (3) Cylindrical lens
- (4) Polygon motor (PM)
- (5) Polygon mirror
- (6) $f\theta$ lens
- (7) $f\theta$ lens
- (8) PD sensor mirror
- (9) Cylindrical correcting lens
- (10) PD PWB (PDPWB)

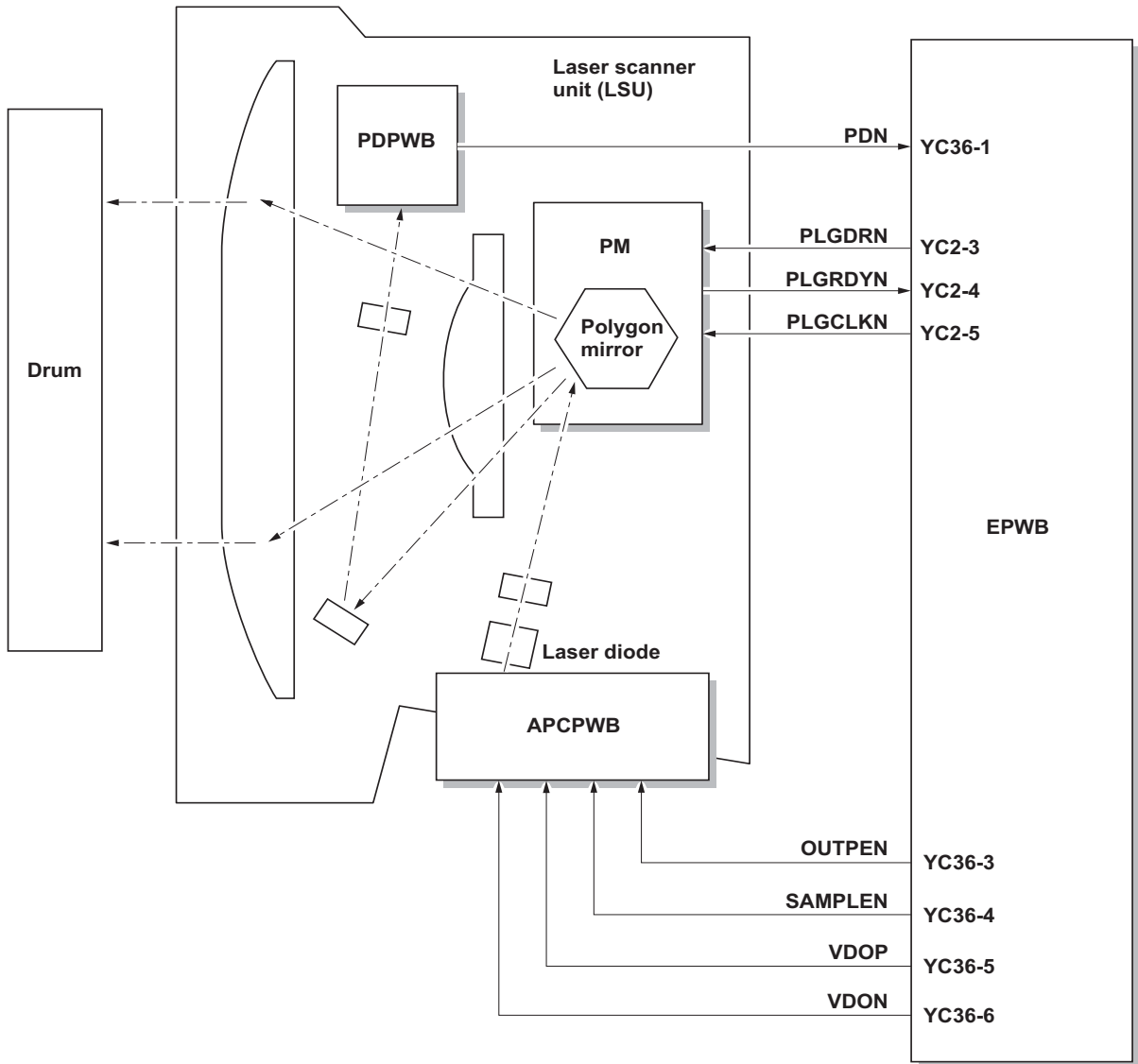

Figure 2-1-10 Laser scanner section block diagram

2-1-4 Developing section

The developing unit consists of the developing sleeve where a magnetic brush is formed, the magnetic toner blade and the developing spirals that agitate the toner.

When the toner sensor (TNS) detects a low toner level in the developing unit, the toner replenishment signal is output to the engine PWB (EPWB). The engine PWB (EPWB) that has received the signal turns on the toner feed motor (TFM) and replenishes toner from the toner container to the developing unit.

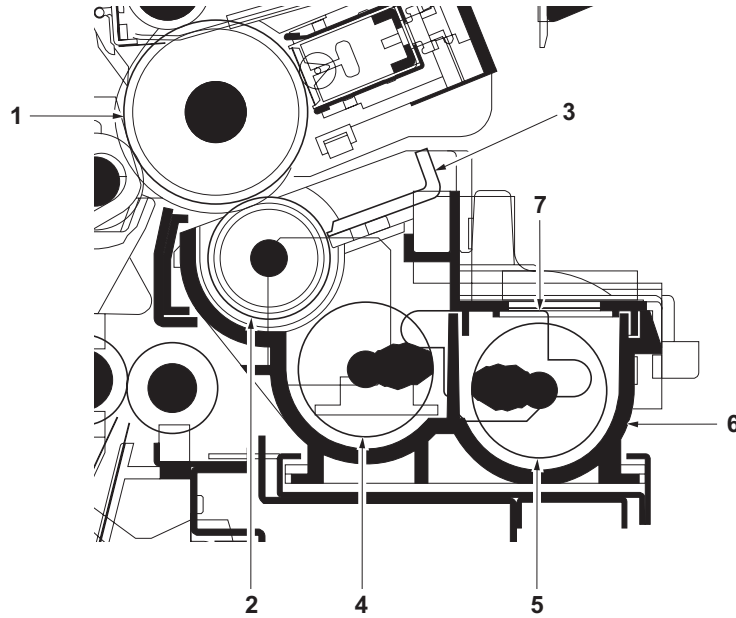

Figure 2-1-11 Developing section

- (1) Drum
- (2) Developing sleeve
- (3) Magnetic toner blade
- (4) Left developing spiral
- (5) Right developing spiral
- (6) Developing housing
- (7) Toner sensor (TNS)

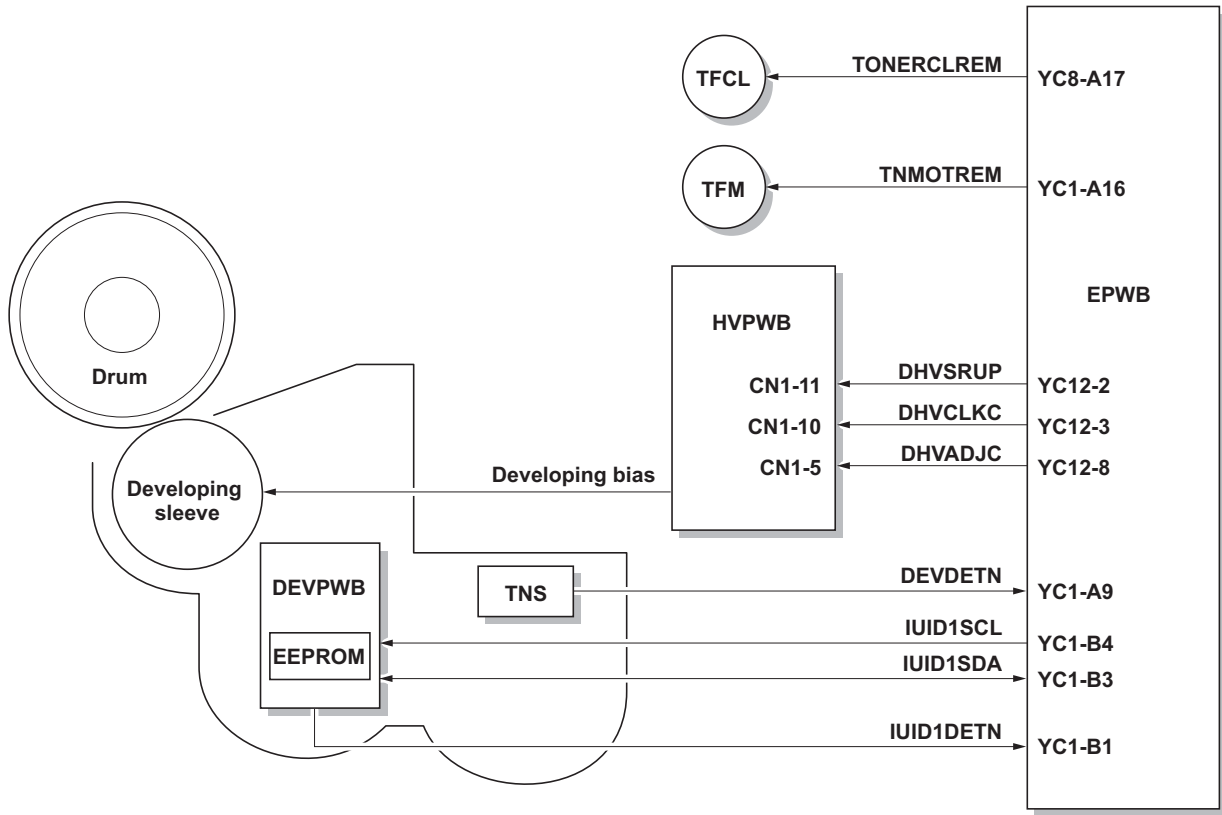

Figure 2-1-12 Developing section block diagram

(1) Single component developing system

This machine uses the single component developing system, and reversal processing is performed with a + charged drum (a-Si) and a + charged magnetic toner.

With the single component developing system, toner is electrically charged by friction with the developing sleeve and + charged when it passes through the magnetic toner blade. The toner that has passed through the magnetic toner blade forms a uniform layer on the developing sleeve. When the toner layer comes to the location where the developing sleeve is the nearest to the drum, toner moves between the drum and the developing sleeve by an electric field of the magnetic pole. Then, when the developing sleeve rotates and passes through the nearest location to the drum, on the portion of the drum that has been exposed to light, toner is attracted toward the drum by potential difference between the developing bias and the drum surface and development is performed. On the other hand, on the portion of the drum that has not been exposed to light, toner is attracted toward the sleeve and development is not performed. When toner comes to an area where the gap between the drum and the developing sleeve is large, an electric field disappears and toner does not leave the developing sleeve. Development is complete.

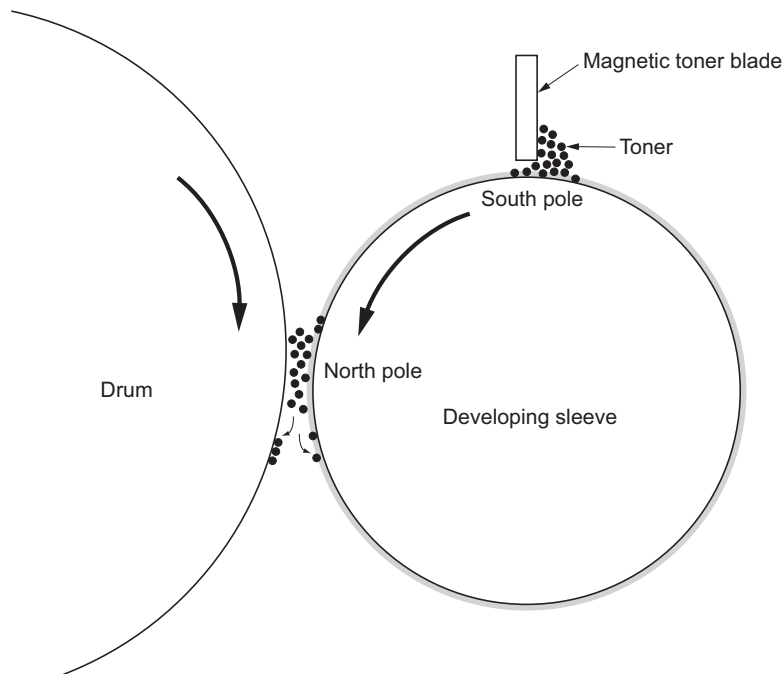

Figure 2-1-13 Single component developing system

2-1-5 Transfer and separation sections

The transfer and separation section consists mainly of the transfer roller, separation electrode and drum separation claws. A high voltage generated by the high voltage PWB (HVPWB) is applied to the transfer roller for transfer charging. Paper after transfer is separated from the drum by applying separation charging that is output from the high voltage PWB (HVPWB) to the separation electrode.

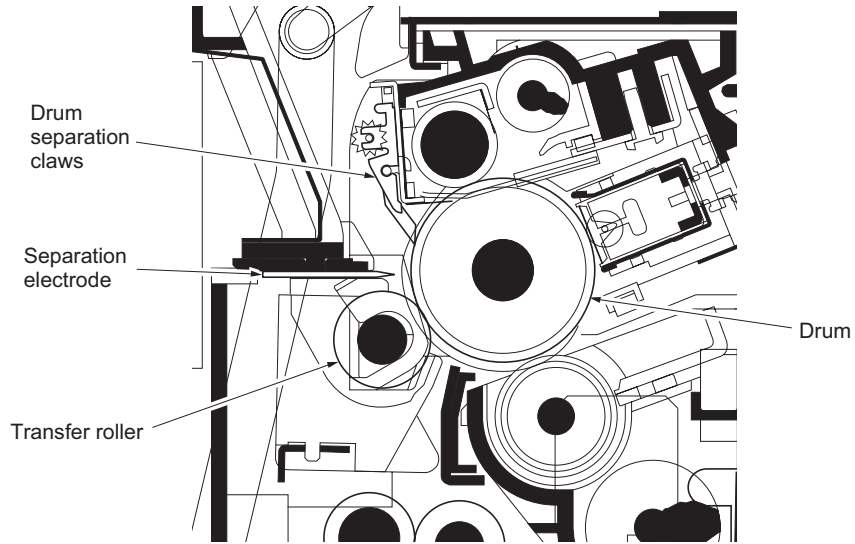

Figure 2-1-14 Transfer and separation sections

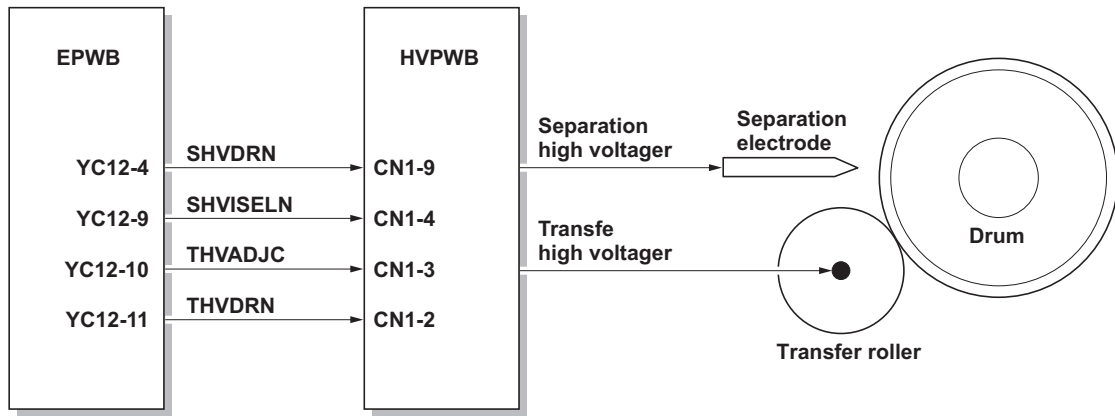

Figure 2-1-15 Transfer and separation sections block diagram

2-1-6 Cleaning and charge erasing sections

The cleaning section consists of the cleaning blade that removes residual toner from the drum surface after the transfer process, and the cleaning spiral that carries the residual toner back to the waste toner box. The cleaning lamp (CL) consists of LEDs and removes residual charge on the drum before main charging. Also the toner quantity in the waste toner box is sensed with the overflow sensor (OFS).

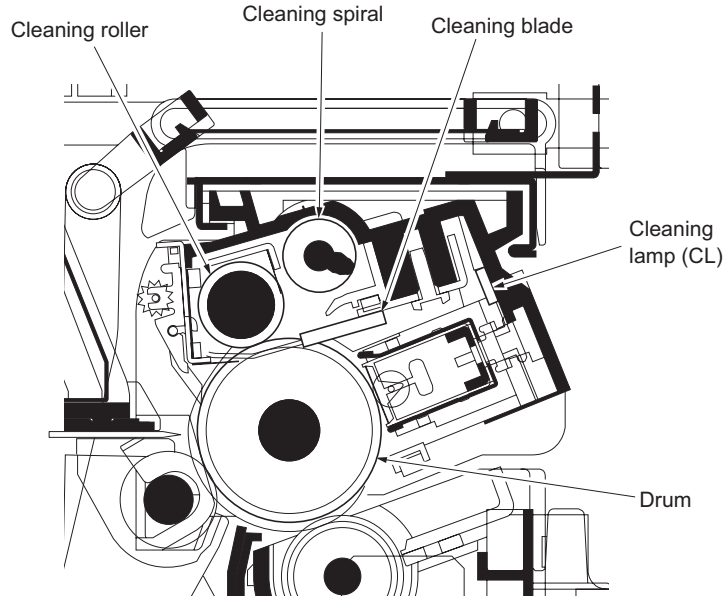

Figure 2-1-16 Cleaning and charge erasing sections

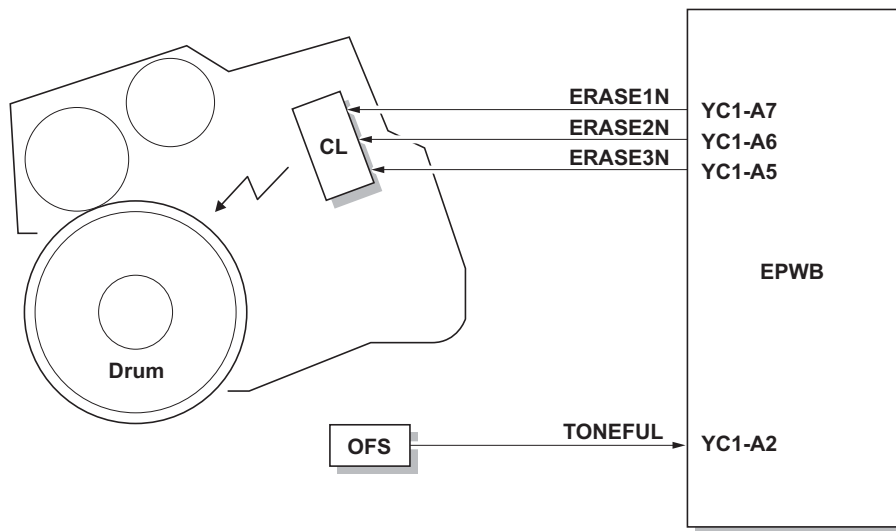

Figure 2-1-17 Cleaning and charge erasing sections block diagram

2-1-7 Fuser section

The fuser section consists of the parts shown in Figure 2-1-18. When paper reaches the fuser section after the transfer process, it passes between the press roller and heat roller, which is heated by fuser heaters 1 or 2 (FH1 or FH2). Pressure is applied by the fuser unit pressure springs so that the toner on the paper is melted, fused and fixed onto the paper. The heat roller is heated by fuser heaters 1 or 2 (FH1 or FH2) inside it; its surface temperature is detected by the fuser thermostat 1 and 2 (FTH1/2), and is regulated by the fuser heaters turning on and off.

If the fuser section becomes abnormally hot, fuser thermostat 1 and 2 (FTH1/2) operates shutting the power to the fuser heaters off. When the fusing process is completed, the paper is separated from the heat roller by its separation claws and is conveyed from the machine to eject and switchback section.

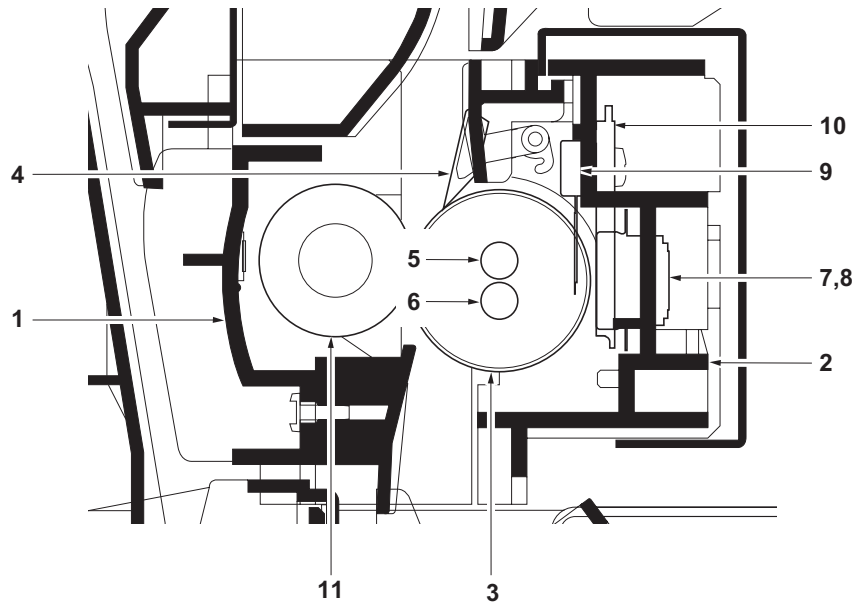

Figure 2-1-18 Fuser section

- (1) Left fuser frame
- (2) Right fuser frame
- (3) Heat roller
- (4) Heat roller separation claws
- (5) Fuser heater 1 (FH1)
- (6) Fuser heater 2 (FH2)
- (7) Fuser thermostat 1 (FTH1)
- (8) Fuser thermostat 2 (FTH2)
- (9) Fuser thermistor 1 (FTH1)
- (10) Fuser thermistor 2 (FTH2)
- (11) Press roller

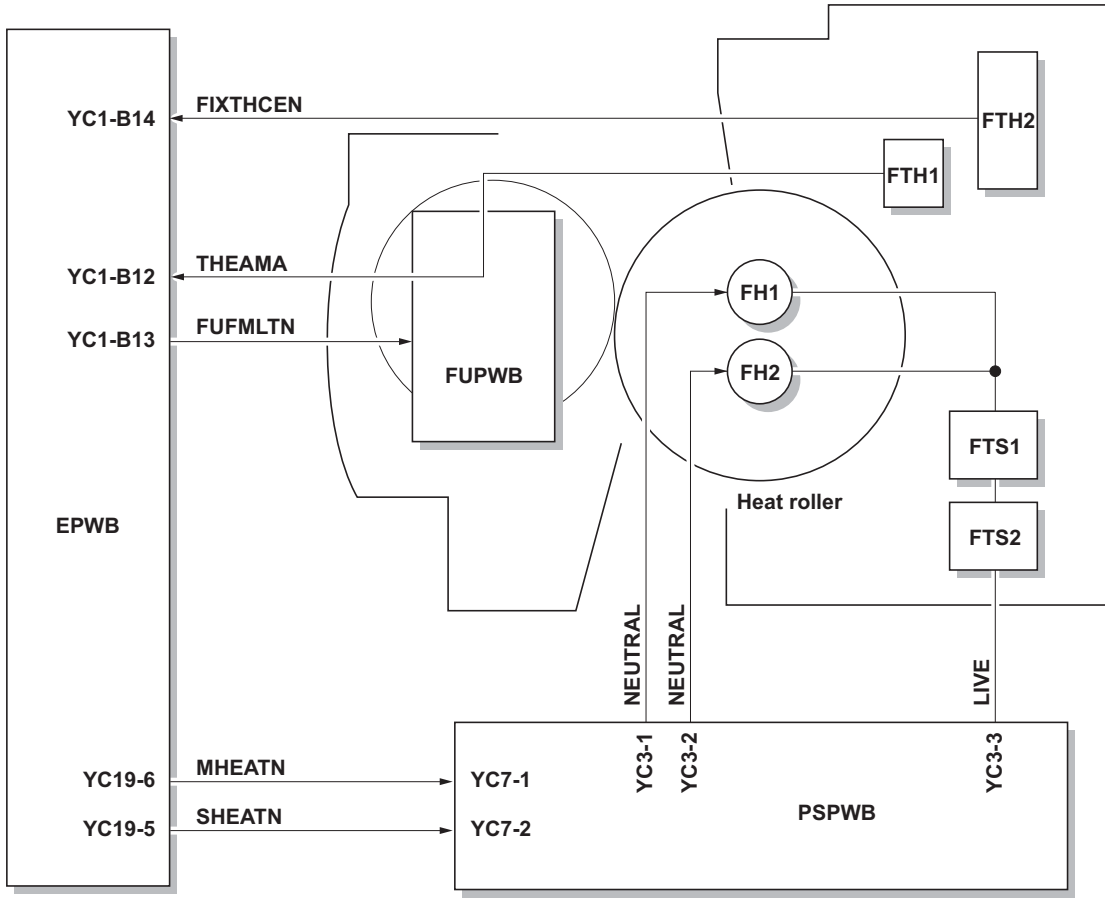

Figure 2-1-19 Fuser section block diagram

2-1-8 Eject and switchback sections

The eject and switchback sections eject paper on which fixing has ended with the eject roller that is rotated by forward rotation of the eject motor.

In duplex copying, paper is turned over by reverse rotation of the eject motor. When paper is transferred to the job separator or the internal finisher, the feedshift solenoid (FSSOL) is turned on to activate the feedshift guide to switch the paper transfer path.

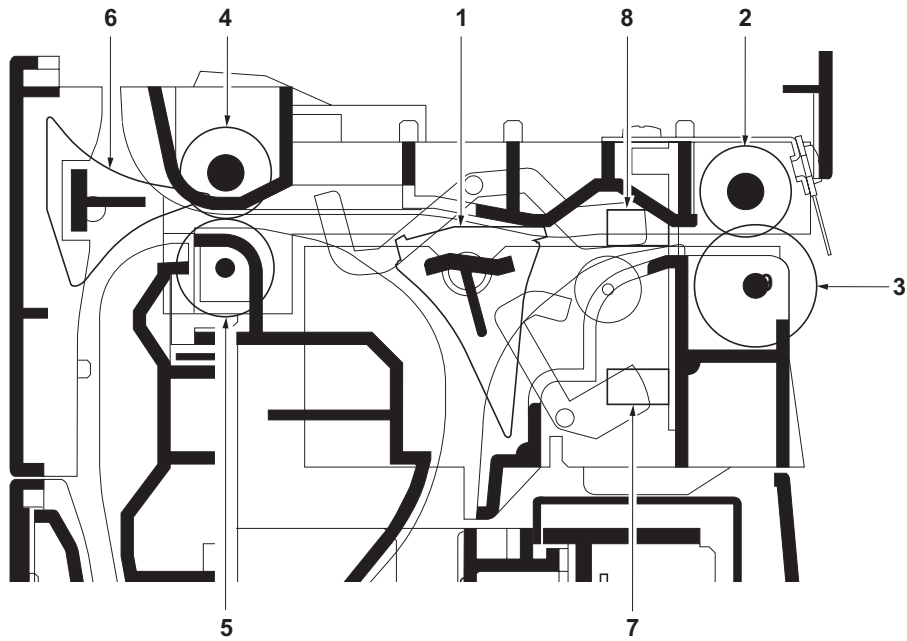

Figure 2-1-20 Eject and switchback sections

- | | |
|-----------------------|-----------------------------|
| (1) Feedshift guide | (5) Switchback pulley |
| (2) Eject roller | (6) Feedshift guide |
| (3) Eject pulley | (7) Eject switch (ESW) |
| (4) Switchback roller | (8) Feedshift switch (FSSW) |

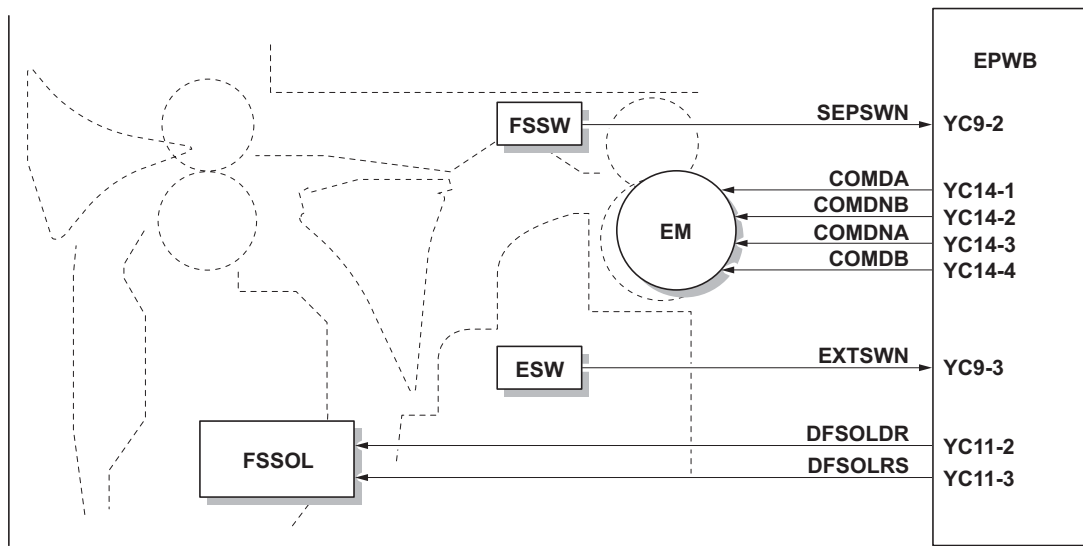

Figure 2-1-21 Eject and switchback sections block diagram

2-1-9 Duplex section

The duplex section consists of the components shown in figure. In duplex mode, after copying on to the reverse face of the paper, the paper is reversed in the switchback section and conveyed to the duplex section. The paper is then conveyed to the paper feed section by the upper and lower duplex feed rollers.

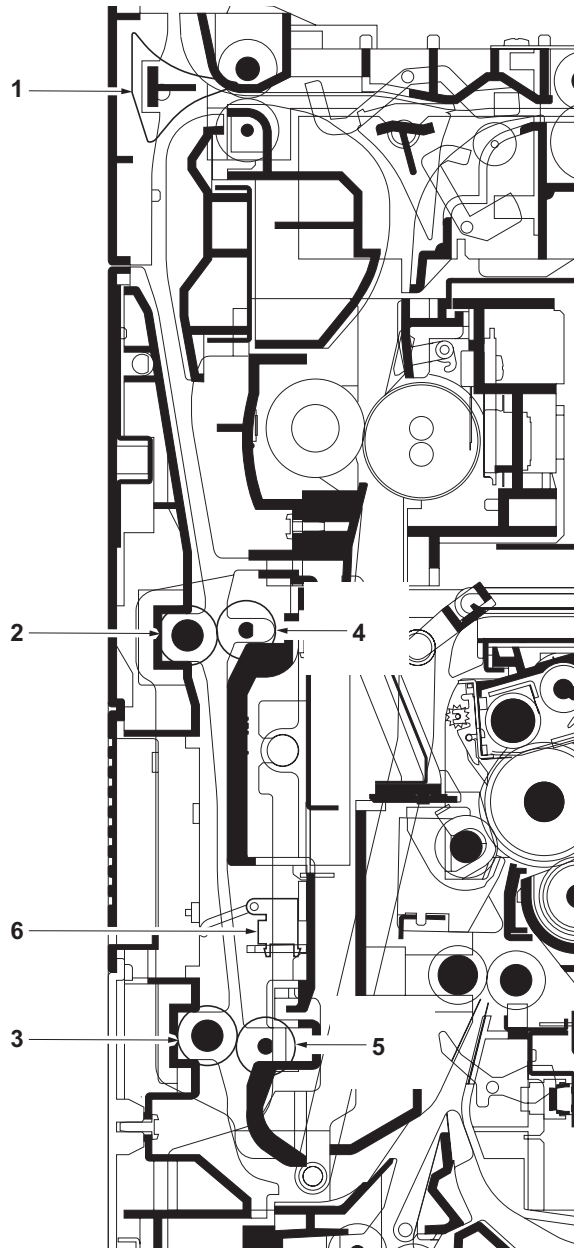

Figure 2-1-22 Duplex section

- (1) Feedshift guide
- (2) Upper duplex feed roller
- (3) Lower duplex feed roller
- (4) Duplex feed pulley
- (5) Duplex feed pulley
- (6) Duplex paper conveying switch (DUPPCSW)

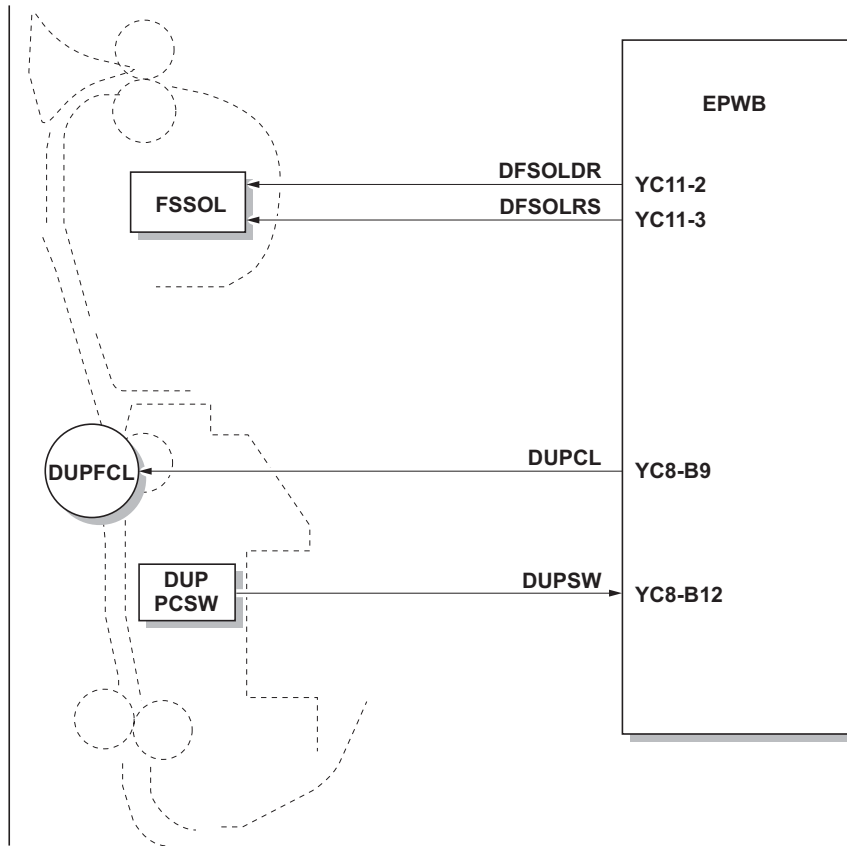

Figure 2-1-23 Duplex section block diagram

(1) Paper conveying operation in duplex copying

Paper of which copying onto the reverse side is complete is conveyed to the switchback section, the eject motor switches from normal rotation to reverse rotation to switch the eject roller to reverse rotation, and the paper conveying direction is reversed. Paper that has been switched back is conveyed to the duplex section via the eject roller and the switchback roller.

Paper that has been conveyed to the duplex section is conveyed to the paper feed section again by rotation of the upper duplex feed roller and the lower duplex feed roller and copying onto the front side is performed.

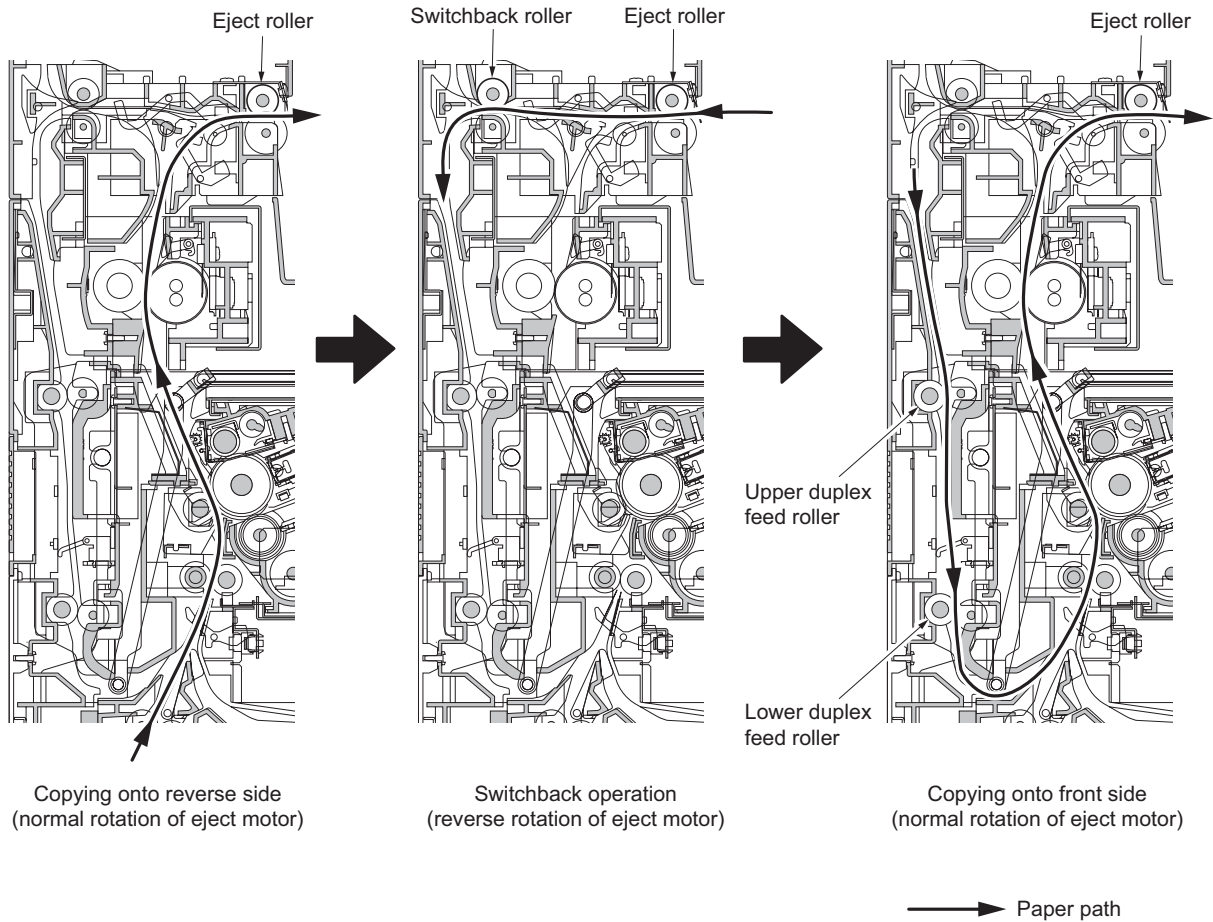

Figure 2-1-24

This page is intentionally left blank.

2-2-1 Electrical parts layout

(1) PWBs

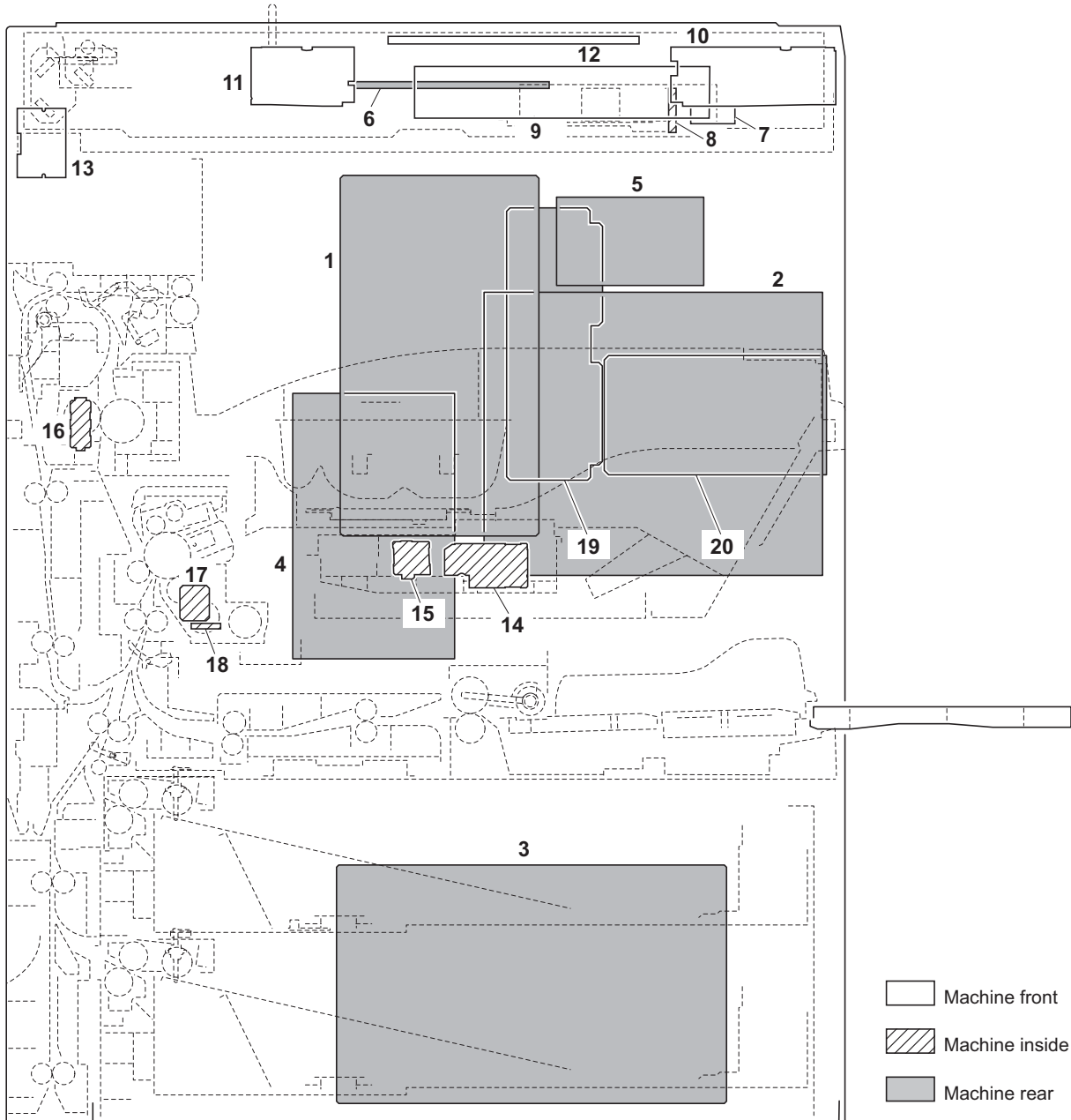

Figure 2-2-1 PWBs

- 1. Engine PWB (EPWB)..... Controls the other PWBs, electrical components and optional devices.
- 2. Main PWB (MPWB) Controls the image processing and operation panel.
- 3. Power source PWB (PSPWB) Generates +24 V DC and 5 V DC; controls the fuser heaters.
- 4. High voltage PWB (HVPWB) Main charging. Generates developing bias and high voltages for transfer.
- 5. Scanner PWB (SPWB) Controls the scanner section.
- 6. Inverter PWB (INPWB) Controls the exposure lamp.
- 7. LCD inverter PWB (LINPWB) Controls LCD indication.
- 8. CCD PWB (CCDPWB)..... Reads the image of originals.
- 9. Main operation unit PWB (OPWB-M)..... Controls touch panel and LCD indication.
- 10. Right operation unit PWB (OPWB-R) Consists of the operation keys and display LEDs.
- 11. Left operation unit PWB (OPWB-L) Consists of the operation keys and display LEDs.
- 12. Upper operation unit PWB (OPWB-U) Consists of the operation keys and display LEDs.

13. Front operation unit PWB (OPWB-F)..... Consists of the display LEDs.
 14. APC PWB (APCPWB) Generates and controls the laser beam.
 15. PD PWB (PDPWB) Controls horizontal synchronizing timing of laser beam.
 16. Fuser PWB (FUPWB) Consists of wiring relay circuits.
 17. Drum PWB (DRPWB) Stores the individual drum unit information.
 18. Developing PWB (DRPWB) Stores the individual developing unit information.
 19. Interface PWB (IFPWB) Consists of wiring relay circuits.
 20. Fax control PWB (FCPWB)* Modulates, demodulates, compresses, decompresses and smoothes out image data, and converts resolution of image data.

*: Option

List of correspondences of PWB names

No.	Name used in service manual	Name used in parts list
1	Engine PWB (EPWB)	PARTS,PWB ENGINE ASS'Y,SP
2	Main PWB (MPWB)	PARTS,PWB MAIN ASS'Y,SP
3	Power source PWB (PSPWB)	PARTS LVU 100/PARTS LVU 200
4	High voltage PWB (HVPWB)	PARTS,HIGH VOLTAGE,SP
5	Scanner PWB (SPWB)	PARTS PWB SCANNER ASSY SP
6	Inverter PWB (INPWB)	PARTS,LAMP INVERTER,SP
7	LCD inverter PWB (LINPWB)	PARTS,LCD INVERTER,SP
8	CCD PWB (CCDPWB)	-
9	Main operation PWB (OPWB-M)	PARTS,PWB PANEL ASS'Y,SP
10	Right operation PWB (OPWB-R)	PARTS,PWB OPERATION RIGHT ASS'Y,SP
11	Left operation PWB (OPWB-L)	PARTS,PWB OPERATION LEFT ASS'Y,SP
12	Upper operation PWB (OPWB-U)	OPERATION UPPER PWB ASS'Y
13	Front operation PWB (OPWB-F)	OPERATION FRONT PWB ASS'Y
14	APC PWB (APCPWB)	-
15	PD PWB (PDPWB)	-
16	Fuser PWB (FUPWB)	-
17	Drum PWB (DRPWB)	-
18	Developing PWB (DEVPWB)	-
19	Interface PWB (IFPWB)	PARTS,PWB KUIO PWB ASS'Y
20	Fax control PWB (FCPWB)	-

(2) Switches and sensors

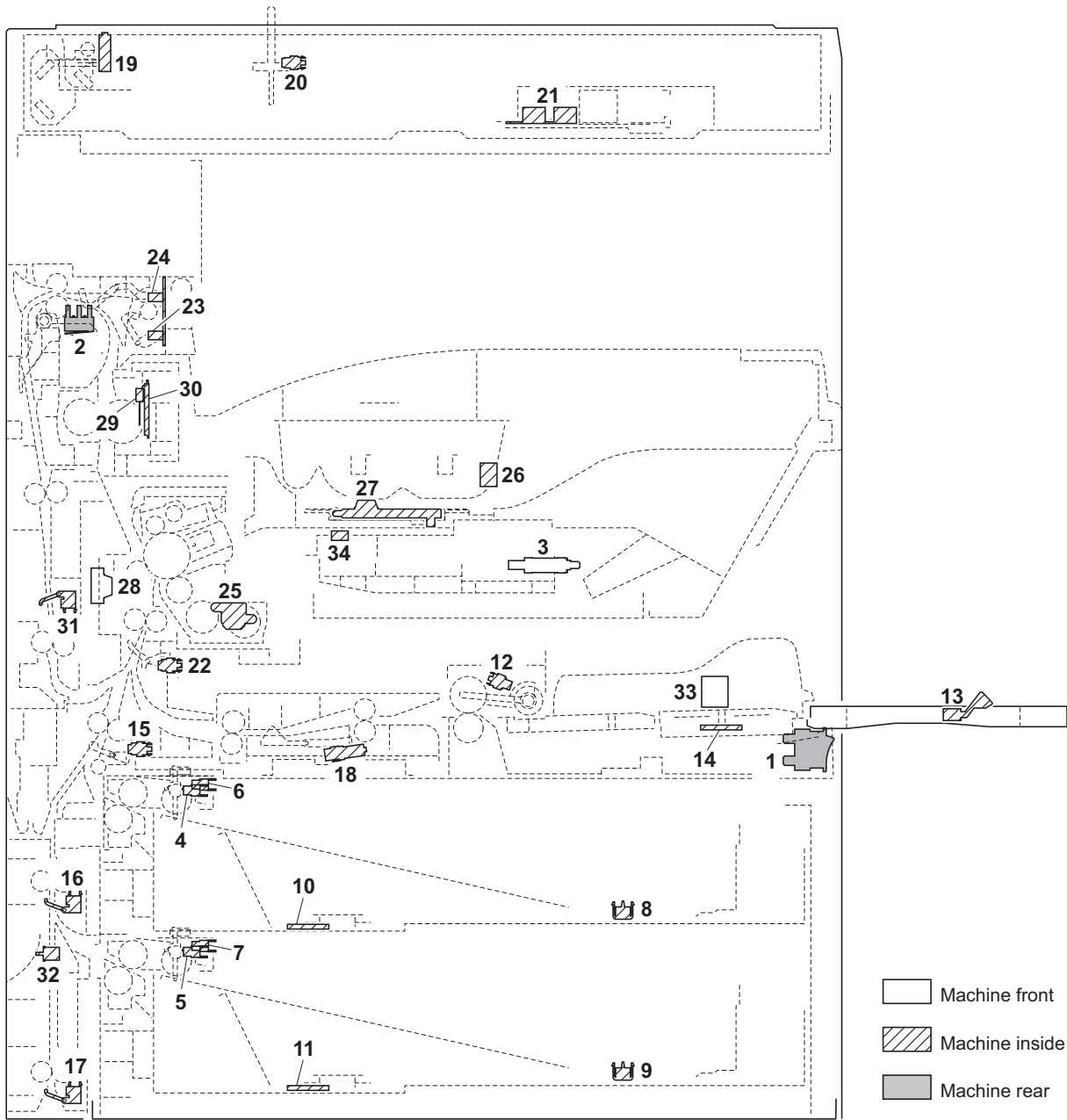

Figure 2-2-2 Switches and sensors

- 1. Main power switch (MSW) Turns the AC power on and off.
- 2. Safety switch 1 (SSW1) Breaks the safety circuit when the left cover 1 is opened.
- 3. Safety switch 2 (SSW2) Breaks the safety circuit when the front cover is opened.
- 4. Paper switch 1 (PSW1) Detects the presence of paper in the cassette 1.
- 5. Paper switch 2 (PSW2) Detects the presence of paper in the cassette 2.
- 6. Lift switch 1 (LSW1) Detects lift reaching the upper limit in cassette 1.
- 7. Lift switch 2 (LSW2) Detects lift reaching the upper limit in cassette 2.
- 8. Paper size length switch 1 (PLSW1) Detects the length of paper in the cassette 1.
- 9. Paper size length switch 2 (PLSW2) Detects the length of paper in the cassette 2.
- 10. Paper size width switch 1 (PWSW1) Detects the width of paper in the cassette 1.
- 11. Paper size width switch 2 (PWSW2) Detects the width of paper in the cassette 2.
- 12. MP paper switch (MPPSW) Detects the presence of paper on the MP tray.
- 13. MP paper size length switch (MPPLSW) Detects the length of paper on the MP tray.
- 14. MP paper size width switch (MPPWSW) Detects the width of paper on the MP tray.
- 15. Feed switch 1 (FSW1) Controls feed clutch 1 drive timing.

- 16. Feed switch 2 (FSW2) Controls feed clutch 2 drive timing
- 17. Feed switch 3 (FSW3) Controls feed clutch 3 drive timing
- 18. MP feed switch (MPFSW)..... Controls MP feed clutch drive timing
- 19. Home position switch (HPSW)..... Detects the optical system in the home position.
- 20. Original detection switch (ODSW) Operates the original size detection sensor.
- 21. Original size sensor (OSS) Detects the size of the original.
- 22. Registration switch (RSW) Controls the secondary paper feed start timing.
- 23. Eject switch (ESW) Detects a paper misfeed in the fuser section.
- 24. Feedshift switch (FSSW) Detects a paper misfeed in the switchback section in a duplex copy.
- 25. Toner sensor (TNS)..... Detects the toner density in the developing unit.
- 26. Toner container detection switch
(TCDSW) Detects the presence of the toner container.
- 27. Toner container sensor (TCS)..... Detects the quantity of toner in a toner container.
- 28. Overflow sensor (OFS) Detects when the waste toner box is full.
- 29. Fuser thermistor 1 (FTH1) Detects the heat roller temperature.
- 30. Fuser thermistor 2 (FTH2) Detects the heat roller temperature.
- 31. Duplex paper conveying switch
(DUPPCSW) Detects a paper jam in the duplex section.
- 32. Left cover 2 switch (LC2SW) Detects the opening and closing of the left cover 2.
- 33. Humidity sensor (HUMS) Detects absolute humidity.
- 34. Temperature sensor (TEMS)..... Detects inner temperature.

(3) Motors

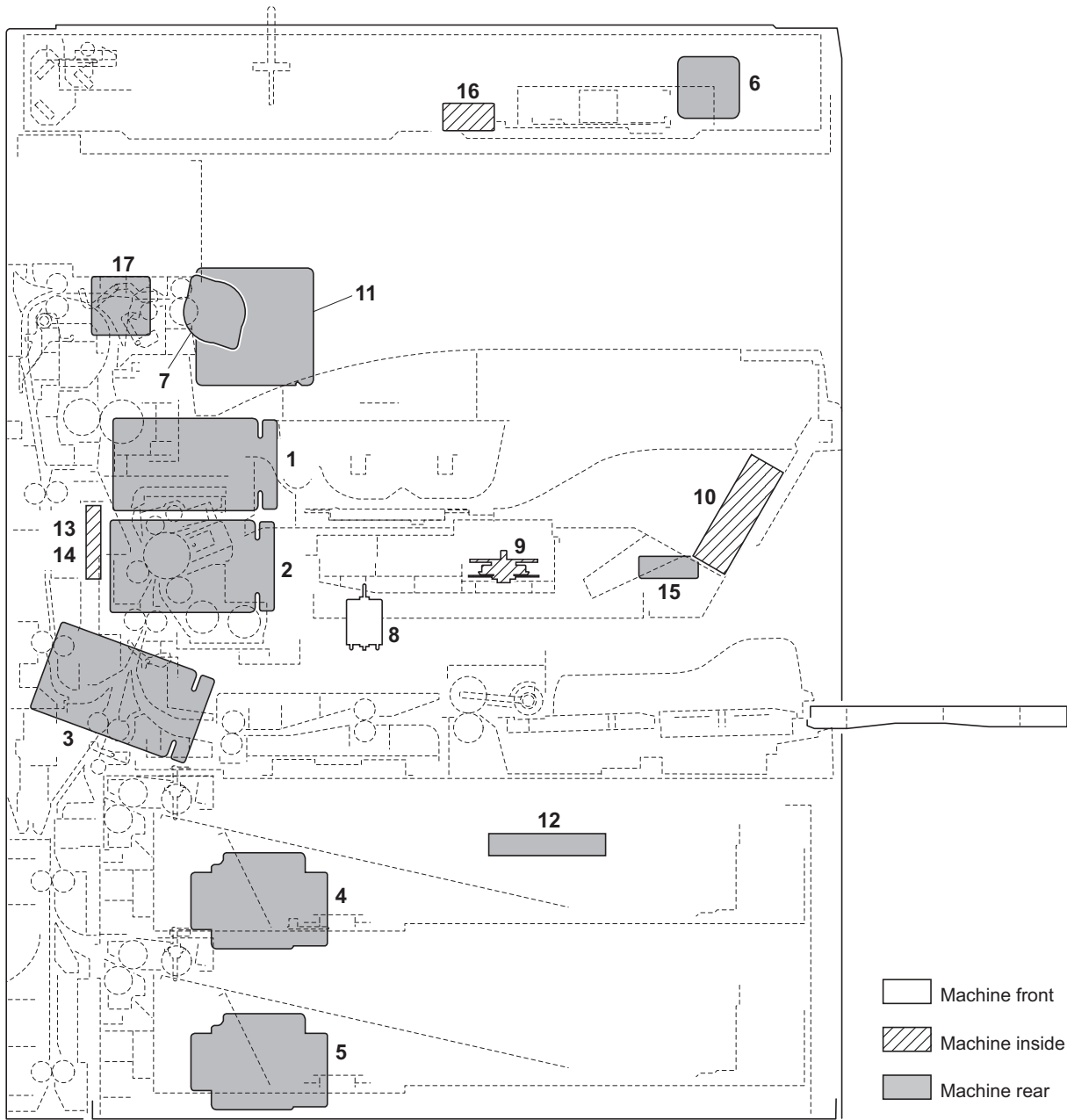

Figure 2-2-3 Motors

- | | |
|--|--|
| 1. Main motor (MM)..... | Drives developing section and fuser section. |
| 2. Drum motor (DM)..... | Drives the drum. |
| 3. Paper feed motor (PFM)..... | Drives paper feed section. |
| 4. Lift motor 1 (LM1)..... | Drives cassette 1 lift. |
| 5. Lift motor 2 (LM2)..... | Drives cassette 2 lift. |
| 6. Scanner motor (SM)..... | Drives the optical system. |
| 7. Eject motor (EM)..... | Drives the eject section. |
| 8. Toner feed motor (TFM)..... | Replenishes toner. |
| 9. Polygon motor (PM)..... | Drives the polygon mirror. |
| 10. Developing fan motor (DEVFM)..... | Cools the developing section. |
| 11. Fuser fan motor (FUFM)..... | Cools the fuser section. |
| 12. Power source fan motor (PSFM)..... | Cools the power source PWB. |
| 13. Paper conveying fan motor 1 (PCFM1)..... | Cools the machine interior (around the paper conveying). |
| 14. Paper conveying fan motor 2 (PCFM2)..... | Cools the machine interior (around the paper conveying). |
| 15. Controller fan motor (CONFM)..... | Cools the controller box. |

2K5

- 16. Operation fan motor (OFM)..... Cools the operation section.
- 17. Eject fan motor (EFM)..... Cools the eject section.

(4) Clutches and solenoids



Figure 2-2-4 Clutches and solenoids

- 1. Paper feed clutch 1 (PFCL1) Primary paper feed from the cassette 1.
- 2. Paper feed clutch 2 (PFCL2) Primary paper feed from the cassette 2.
- 3. Feed clutch 1 (FCL1) Controls the drive of feed roller.
- 4. Feed clutch 2 (FCL2) Controls the drive of feed roller.
- 5. Feed clutch 3 (FCL3) Controls the drive of feed roller.
- 6. MP paper feed clutch (MPPFCL) Primary paper feed from the MP tray.
- 7. MP feed clutch (MPFCL) Controls the drive of MP feed roller.
- 8. Registration clutch (RCL) Secondary paper feed.
- 9. Duplex feed clutch (DUPFCL) Controls the drive of the duplex feed roller.
- 10. Toner feed clutch (TFCL) Replenishes toner.
- 11. Feedshift solenoid (FSSOL) Operates the feedshift guide.

(5) Other electrical components

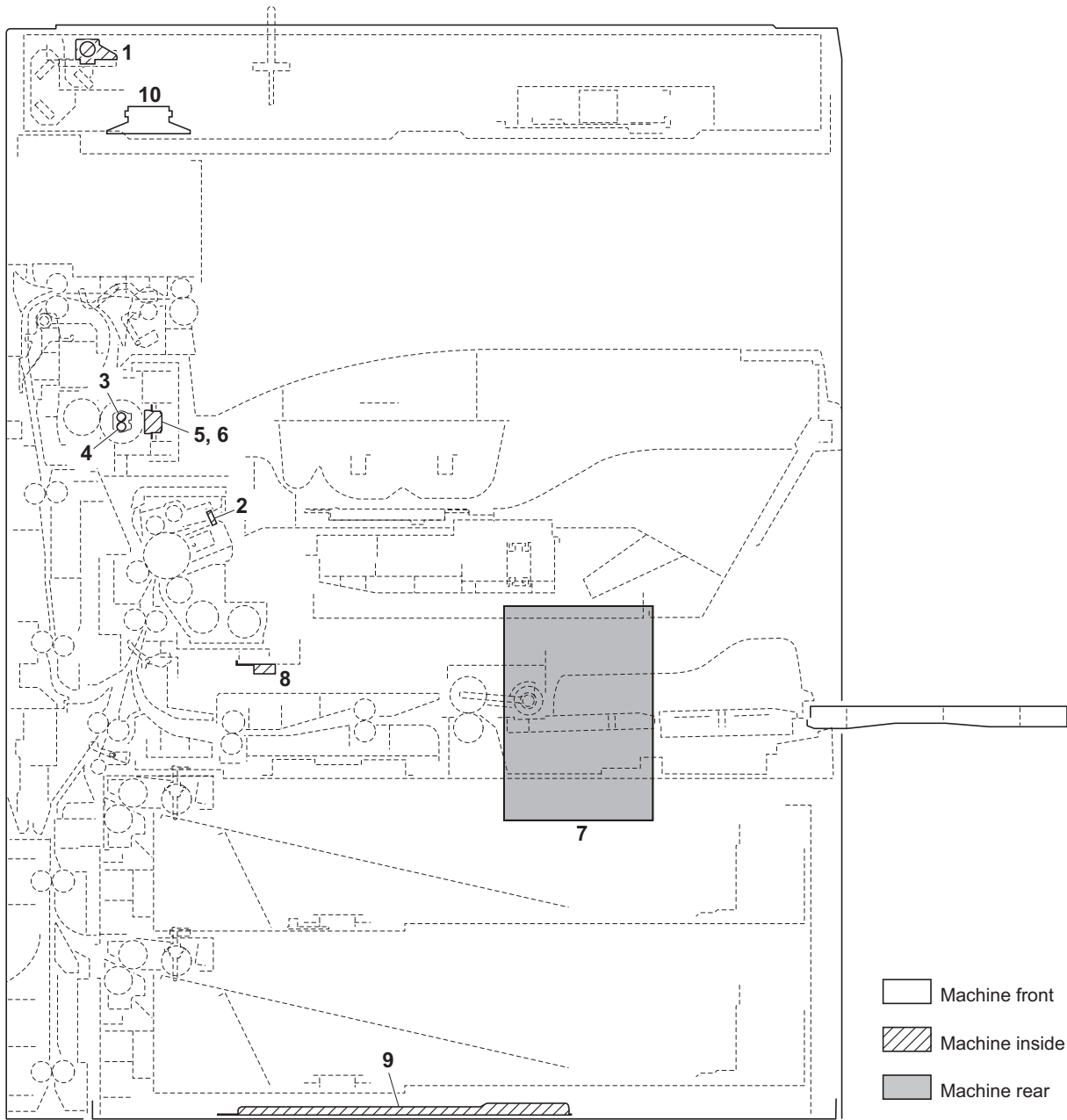

Figure 2-2-5 Other electrical components

- | | |
|------------------------------------|---|
| 1. Exposure lamp (EL) | Exposes originals. |
| 2. Cleaning lamp (CL) | Removes residual charge from the drum surface. |
| 3. Fuser heater 1 (FH1) | Heats the heat roller. |
| 4. Fuser heater 2 (FH2) | Heats the heat roller. |
| 5. Fuser thermostat 1 (FTS1) | Prevents overheating in the fuser section. |
| 6. Fuser thermostat 2 (FTS2) | Prevents overheating in the fuser section. |
| 7. Hard disk unit (HDD) | Stores the image data and information of job accounting mode. |
| 8. Drum heater (DH) | Dehumidifies the image formation section. |
| 9. Cassette heater (CH) | Dehumidifies the cassette section. |
| 10. Speaker (SP) | Outputs buzzer, monitoring and speaker sounds. |

2-3-1 Power source PWB

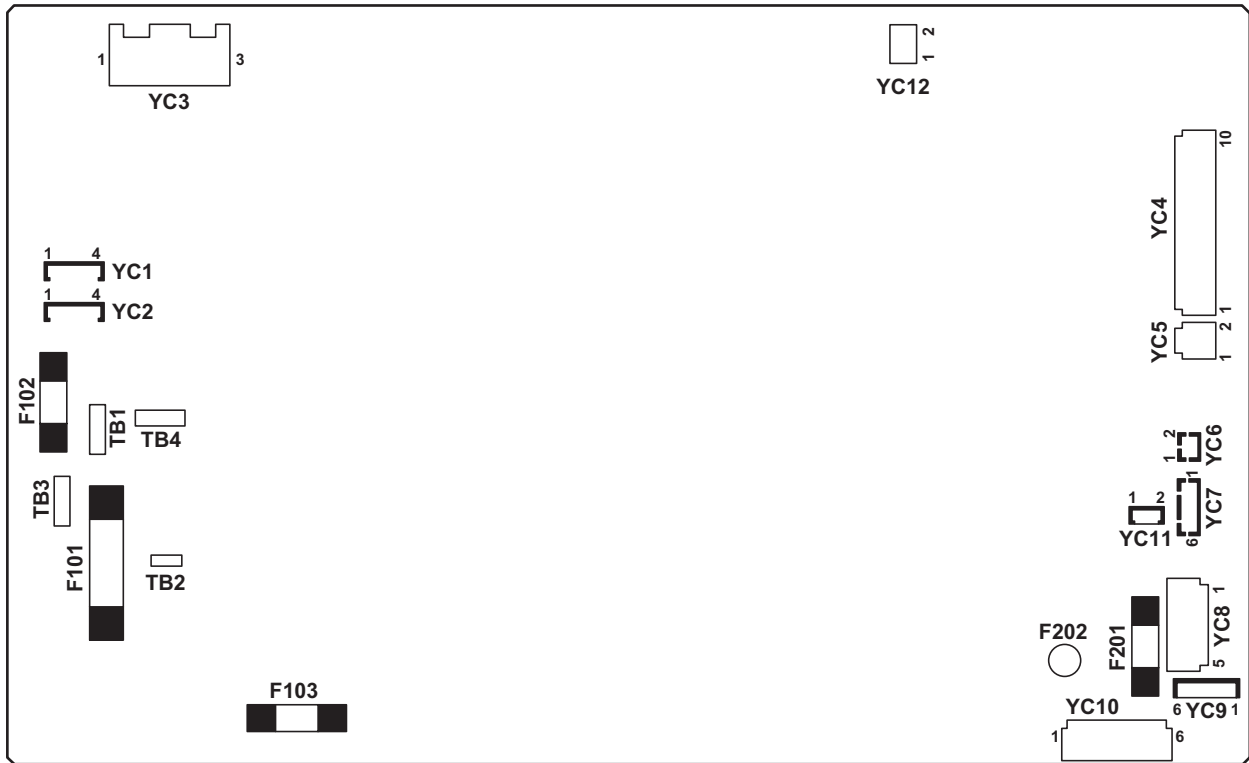

Figure 2-3-1 Power source PWB silk-screen diagram

Connector	Pin No.	Signal	I/O	Voltage	Description
TB Connected to the AC inlet and main power switch	TB1	LIVE	I	120 V AC 220-240 V AC	AC power input
	TB2	NEUTRAL	I	120 V AC 220-240 V AC	AC power input
	TB3	LIVE	O	120 V AC 220-240 V AC	AC power output to MSW
	TB4	LIVE	I	120 V AC 220-240 V AC	AC power input from MSW
YC1 Connected to the cassette heater	1	LIVE	O	120 V AC 220-240 V AC	AC power output
	2	N.C.	-	-	Not used
	3	N.C.	-	-	Not used
	4	NEUTRAL	O	120 V AC 220-240 V AC	AC power output
YC2 Connected to the cassette heater	1	LIVE	O	120 V AC 220-240 V AC	AC power output
	2	N.C.	-	-	Not used
	3	N.C.	-	-	Not used
	4	NEUTRAL	O	120 V AC 220-240 V AC	AC power output
YC3 Connected to the fuser heater 1/2 and relay PWB	1	MH	O	120/0 V AC 220-240/0 V AC	FH1: On/Off
	2	SH	O	120/0 V AC 220-240/0 V AC	FH2: On/Off
	3	LIVE	O	120 V AC 220-240 V AC	AC power output to RYPWB
YC4 Connected to the main PWB	1	+5V	O	5 V DC	5 V DC power output to MPWB
	2	+5V	O	5 V DC	5 V DC power output to MPWB
	3	+5VSL	O	5 V DC	5 V DC power output to MPWB
	4	+12VSL	O	12 V DC	12 V DC power output to MPWB
	5	+24VSL	O	24 V DC	24 V DC power output to MPWB
	6	GND	-	-	Ground
	7	GND	-	-	Ground
	8	GND	-	-	Ground
	9	GND	-	-	Ground
	10	GND	-	-	Ground
YC6 Connected to the power source fan motor	1	FAN7DRN	O	0/24 V DC	PSFM: On/Off
	2	+24VSL	O	24 V DC	24 V DC power output to PSFM
YC7 Connected to the engine PWB	1	MHEATN	I	0/5 V DC	FH-M: On/Off
	2	SHEATN	I	0/5 V DC	FH-S: On/Off
	3	FAN7DRN	I	0/24 V DC	PSFM: On/Off
	4	GND	-	-	Ground
	5	ZCROSSC	O	0/5 V DC (pulse)	Zero-cross signal
	6	SLEEPN	O	0/5 V DC	Sleep signal: On/Off

Connector	Pin No.	Signal	I/O	Voltage	Description
YC8 Connected to the engine PWB	1	+5VSL	O	5 V DC	5 V DC power output to EPWB
	2	GND	-	-	Ground
	3	GND	-	-	Ground
	4	+24VSL	O	24 V DC	24 V DC power output to EPWB
	5	+24VSL	O	24 V DC	24 V DC power output to EPWB
YC9 Connected to the optional document finisher	1	GND	-	-	Ground
	2	GND	-	-	Ground
	3	GND	-	-	Ground
	4	GND	-	-	Ground
	5	GND	-	-	Ground
	6	GND	-	-	Ground
YC10 Connected to the optional paper feeder and optional document finisher	1	+5VSL	O	5 V DC	5 V DC power output to document finisher
	2	+24VSL	O	24 V DC	24 V DC power output to document finisher
	3	+24VSL	O	24 V DC	24 V DC power output to paper feeder
	4	GND	-	-	Ground
	5	GND	-	-	Ground
	6	NC	-	-	Not used
YC12 Connected to the engine PWB	1	N.C.	-	-	Not used
	2	+24VIL3	O	24 V DC	24 V DC power output to EPWB

2-3-2 Engine PWB

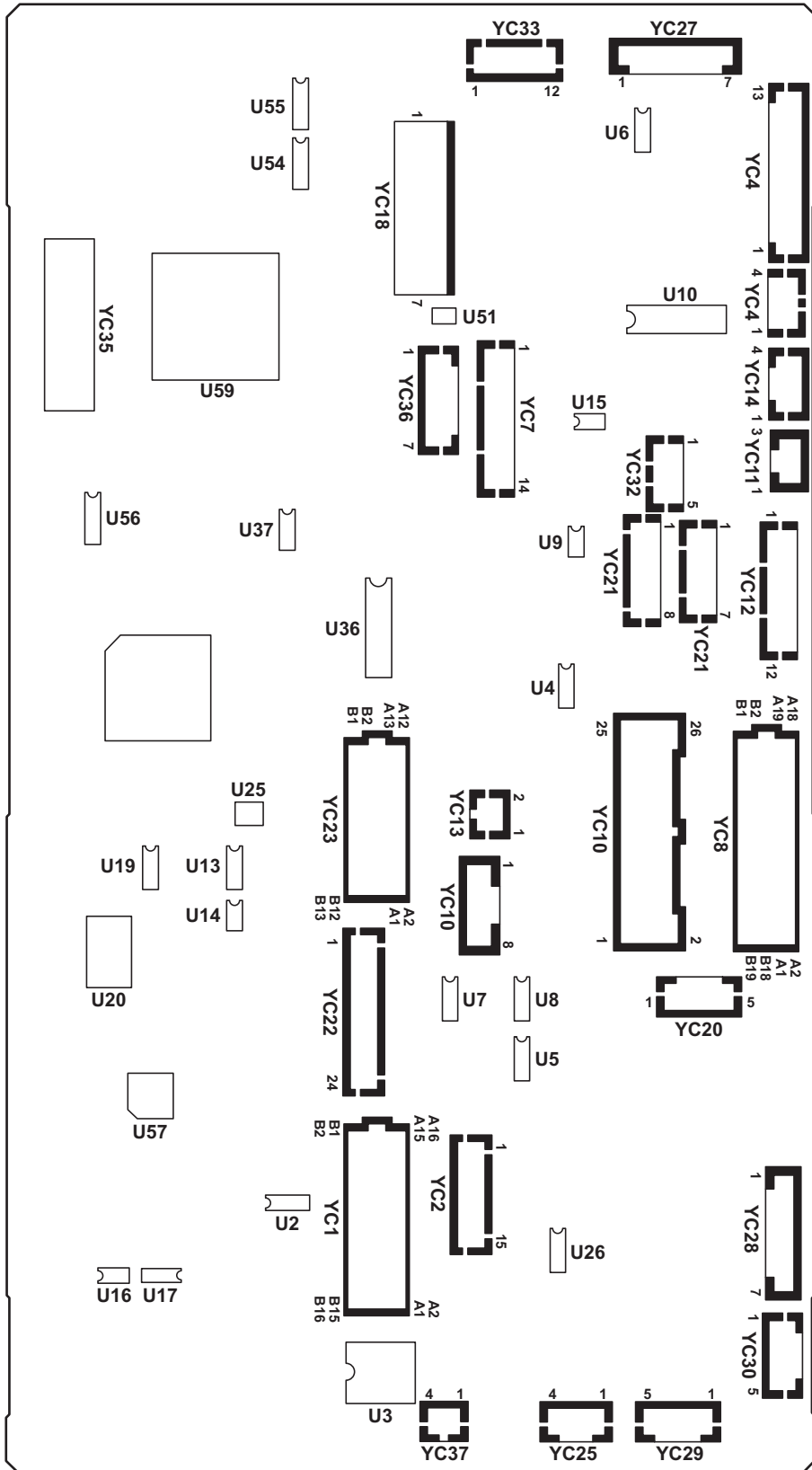

Figure 2-3-2 Engine PWB silk-screen diagram

Connector	Pin No.	Signal	I/O	Voltage	Description	
Connected to the overflow sensor, cleaning lamp, toner sensor, humidity sensor, toner feed motor, developing PWB, drum PWB and fuser unit	YC1	A1	GND	-	-	Ground
	A2	TONEFUL	I	0/5 V DC		OFS: On/Off
	A3	+5V	O	5 V DC		5 V DC power output to OFS
	A4	+24VIL2	O	24 V DC		24 V DC power output to CL
	A5	ERASE3N	O	0/24 V DC		CL: On/Off
	A6	ERASE2N	O	0/24 V DC		CL: On/Off
	A7	ERASE1N	O	0/24 V DC		CL: On/Off
	A8	GND	-	-		Ground
	A9	DEVDETN	I	0/5 V DC		TNS: On/Off
	A10	+5VSL	O	5 V DC		5 V DC power output to TNS
	A11	+5VSL	O	5 V DC		5 V DC power output to HUMS
	A12	HUMID_SDA	I/O	Analog		HUMS detection voltage signal
	A13	GND	-	-		Ground
	A14	HUMID_SCL	O	0/5 V DC (pulse)		HUMS clock signal
	A15	TNMOT24V	O	24 V DC		24 V DC power output to TFM
	A16	TNMOTREM	O	0/24 V DC		TFM: On/Off
	B1	IUID1DET N	I	0/5 V DC		Developing unit detection signal
	B2	GND	-	-		Ground
	B3	IUID1SDA	I/O	0/5 V DC (pulse)		Developing unit EEPROM data signal
	B4	IUID1SCL	O	0/5 V DC (pulse)		Developing unit EEPROM clock signal
	B5	+5VSL	O	5 V DC		5 V DC power output to developing unit
	B6	IUID2DET N	I	0/5 V DC		Drum unit detection signal
	B7	GND	-	-		Ground
	B8	IUID2SDA	I/O	0/5 V DC (pulse)		Drum unit EEPROM data signal
	B9	IUID2SCL	O	0/5 V DC (pulse)		Drum unit EEPROM clock signal
	B10	+5VSL	O	5 V DC		5 V DC power output to drum unit
B11	THEAMA_GND	-	-		Ground	
B12	THEAMA	I	Analog		FTH1 detection voltage signal	
B13	FUFMLTN	O	0/5 V DC		Fuse cut signal	
B14	FIXTHCEN	I	Analog		FTH2 detection voltage signal	
B15	NC	-	-		Not used	
B16	+3.3V	O	3.3 V DC		3.3 V DC power output to FUPWB	
Connected to the polygon motor, developing fan motor, toner container sensor and toner container detection switch	YC2	1	+24VSL	O	24 V DC	24 V DC power output to PM
	2	GND	-	-		Ground
	3	PLGDRN	O	0/24 V DC		PM: On/Off
	4	PLGRDYN	I	0/5 V DC		PM ready signal
	5	PLGCLKN	O	0/5 V DC (pulse)		PM clock signal
	6	FAN1DRN	O	0/24 V DC		DEVFM: On/Off
	7	FAN1POW	O	24 V DC		24 V DC power output to DEVFM
	8	GND	-	-		Ground
	9	COUNTSENS	I	0/5 V DC		TCS: On/Off
	10	+5VSL	O	5 V DC		5 V DC power output to TCS
15	CONTSW	I	0/5 V DC		TCDSW: On/Off	
16	GND	-	-		Ground	

Connector	Pin No.	Signal	I/O	Voltage	Description
YC4 Connected to the optional built-in finisher and optional job separator	1	RLSOLN	O	0/24 V DC	FSSOL (return): On/Off
	2	SLSOLN	O	0/24 V DC	FSSOL (activate): On/Off
	3	SCLK	O	0/5 V DC (pulse)	Built-in finisher/Job separator clock signal
	4	LOPSDI	I	0/5 V DC (pulse)	Built-in finisher serial communication data signal/Job separator JESW: On/Off
	5	LOPSDO	O	0/5 V DC (pulse)	Built-in finisher/Job separator serial communication data signal
	6	LOPRDY	I	0/5 V DC	Built-in finisher ready signal/Job separator EPDSW: On/Off
	7	LOPSEL	O	0/5 V DC	Built-in finisher/Job separator select signal
	8	GND	-	-	Ground
	9	+5VSL	O	5 V DC	5 V DC power output to built-in finisher/Job separator
	10	GND	-	-	Ground
	11	GND	-	-	Ground
	12	+24VSL	O	24 V DC	24 V DC power output to built-in finisher/Job separator
	13	+24VSL	O	24 V DC	24 V DC power output to built-in finisher/Job separator
YC5 Connected to the optional document finisher	1	DET	I	0/5 V DC	Document finisher connection signal
	2	DFSDO	O	0/5 V DC (pulse)	Document finisher serial communication data signal
	3	DFSDI	I	0/5 V DC (pulse)	Document finisher serial communication data signal
	4	DFSCLK	O	0/5 V DC (pulse)	Document finisher clock signal
	5	DFSEL	O	0/5 V DC	Document finisher select signal
	6	SISEL	-	-	Not used
	7	DFRDY	I	0/5 V DC	Document finisher ready signal
	8	SIRDY	-	-	Not used
YC7 Connected to the MP tray unit	1	MPFSIZE0	I	0/5 V DC	MPPWSW: On/Off
	2	MPFSIZE1	I	0/5 V DC	MPPWSW: On/Off
	3	MPFSIZE2	I	0/5 V DC	MPPWSW: On/Off
	4	GND	-	-	Ground
	5	+5VSL	O	5 V DC	5 V DC power output to MPPSW
	6	MPFPAPS	I	0/5 V DC	MPPSW: On/Off
	7	GND	-	-	Ground
	8	+24VSL	O	24 V DC	24 V DC power output to MPPFCL
	9	MPFPAPCL	O	0/24 V DC	MPPFCL: On/Off
	10	+24VSL	O	24 V DC	24 V DC power output to MPFCL
	11	MPFFECL	O	0/24 V DC	MPFCL: On/Off
	12	+5VSL	O	5 V DC	5 V DC power output to MPPLSW
	13	MPFLENGTH	I	0/5 V DC	MPPLSW: On/Off
	14	GND	-	-	Ground

Connector	Pin No.	Signal	I/O	Voltage	Description
Connected to the feed switch 1/2/3, feed clutch 1/2/3, left cover 2 switch, paper feed clutch 1/2, toner feed clutch, registration switch, registration clutch, duplex feed clutch, duplex paper conveying switch and paper conveying fan motor 1/2	A1	GND	-	-	Ground
	A2	LFEED_SW3	I	0/5 V DC	FSW3: On/Off
	A3	+5VSL	O	5 V DC	5 V DC power output to FSW3
	A4	+24VSL	O	24 V DC	24 V DC power output to FCL3
	A5	FEED3CL	O	0/24 V DC	FCL3: On/Off
	A6	GND	-	-	Ground
	A7	LFEED_SW2	I	0/5 V DC	FSW2: On/Off
	A8	+5VSL	O	5 V DC	5 V DC power output to FSW2
	A9	GND	-	-	Ground
	A10	FECOSW	I	0/5 V DC	LC2SW: On/Off
	A11	+24VSL	O	24 V DC	24 V DC power output to FCL2
	A12	FEED2CL	O	0/24 V DC	FCL2: On/Off
	A13	UPFECL	O	0/24 V DC	PFCL1: On/Off
	A14	+24VDUP	O	24 V DC	24 V DC power output to PFCL1
	A15	LOFECL	O	0/24 V DC	PFCL2: On/Off
	A16	+24VDL	O	24 V DC	24 V DC power output to PFCL2
	A17	TONERCLREM	O	0/24 V DC	TFCL: On/Off
	A18	TONERCL+24V	O	24 V DC	24 V DC power output to TFCL
	A19	NC	-	-	Not used
	B1	GND	-	-	Ground
	B2	RESISTSW	I	0/5 V DC	RSW: On/Off
	B3	+5VSL	O	5 V DC	5 V DC power output to RSW
	B4	GND	-	-	Ground
	B5	UFEED_SW	I	0/5 V DC	FSW1: On/Off
	B6	+5VSL	O	5 V DC	5 V DC power output to FSW1
	B7	+24VSL	O	24 V DC	24 V DC power output to FCL1
	B8	FEED1CL	O	0/24 V DC	FCL1: On/Off
	B9	DUPCL	O	0/24 V DC	DUPFCL: On/Off
	B10	+24VSL	O	24 V DC	24 V DC power output to DUPFCL
	B11	GND	-	-	Ground
	B12	DUPSW	I	0/5 V DC	DUPPCSW: On/Off
B13	+5VSL	O	5 V DC	5 V DC power output to DUPPCSW	
B14	+24VSL	O	24 V DC	24 V DC power output to RCL	
B15	RESFECL	O	0/24 V DC	RCL: On/Off	
B16	FAN4REM	O	0/24 V DC	PCFM1: On/Off	
B17	+24VSL	O	24 V DC	24 V DC power output to PCFM1	
B18	FAN5REM	O	0/24 V DC	PCFM2: On/Off	
B19	+24VSL	O	24 V DC	24 V DC power output to PCFM2	
Connected to the feed-shift switch and eject switch	1	GND	-	-	Ground
	2	EXTSWN	I	0/5 V DC	ESW: On/Off
	3	SEPSWN	I	0/5 V DC	FSSW: On/Off
	4	+5VSL	O	5 V DC	5 V DC power output to FSSW/ESW

Connector	Pin No.	Signal	I/O	Voltage	Description
YC10 Connected to the main motor, drum motor, paper feed motor and drum heater	1	+24VIL2	O	24 V DC	24 V DC power output to MM
	2	+24VIL2	O	24 V DC	24 V DC power output to DM
	3	+24VIL2	O	24 V DC	24 V DC power output to MM
	4	+24VIL2	O	24 V DC	24 V DC power output to DM
	5	GND	-	-	Ground
	6	GND	-	-	Ground
	7	GND	-	-	Ground
	8	GND	-	-	Ground
	9	MMOTLOCK	I	0/5 V DC	MM lock signal
	10	DMOTLOCK	I	0/5 V DC	DM lock signal
	11	MMOTON	O	0/24 V DC	MM: On/Off
	12	DMOTON	O	0/24 V DC	DM: On/Off
	13	MMOTCWCCW	O	0/5 V DC	MM rotation switch signal
	14	DMOTCWCCW	O	0/5 V DC	DM rotation switch signal
	15	MMOTCLK	O	0/5 V DC (pulse)	MM clock signal
	16	DMOTCLK	O	0/5 V DC (pulse)	DM clock signal
	17	+24VIL2	O	24 V DC	24 V DC power output to PFM
	18	+24VIL2	O	24 V DC	24 V DC power output to PFM
	19	GND	-	-	Ground
	20	GND	-	-	Ground
	21	SMOTLOCK	I	0/5 V DC	PFM lock signal
	22	SMOTON	O	0/24 V DC	PFM: On/Off
	23	SMOTCWCCW	O	0/5 V DC	PFM rotation switch signal
	24	SMOTCLK	O	0/5 V DC (pulse)	PFM clock signal
	25	+24VSL	O	24 V DC	24 V DC power output to DH
	26	DHEATERREM	O	0/24 V DC	DH: On/Off
YC11 Connected to the feed-shift solenoid	1	+24VSL	O	24 V DC	24 V DC power output to FSSOL
	2	DFSOLDR	O	0/24 V DC	FSSOL (activate): On/Off
	3	DFSOLRS	O	0/24 V DC	FSSOL (return): On/Off
YC12 Connected to the high voltage PWB	1	+24VIL2	O	24 V DC	24 V DC power output to HVTPWB
	2	DHVSURUP	O	0/5 V DC	Developing slowup signal
	3	DHVCLKC	O	0/5 V DC (pulse)	Developing bias clock signal
	4	SHVDRN	O	0/5 V DC	Separation high voltage: On/Off
	5	MHVDRN	O	0/5 V DC	Main charging high voltage: On/Off
	6	GND	-	-	Ground
	7	GND	-	-	Ground
	8	DHVADJC	O	Analog	Developing bias adjust signal
	9	SHVISELN	O	0/5 V DC	Separation high voltage switch signal
	10	THVADJC	O	Analog	Transfer high voltage adjust signal
	11	THVDRN	O	0/5 V DC	Transfer high voltage: On/Off
	12	+5VSL	O	5 V DC	5 V DC power output to HVTPWB

Connector	Pin No.	Signal	I/O	Voltage	Description
YC13 Connected to the fuser fan motor	1	FAN2POW	O	24 V DC	24 V DC power output to FUFM
	2	FAN2DRN	O	0/24 V DC	FUFM: On/Off
YC14 Connected to the eject motor	1	COMDA	O	0/24 V DC (pulse)	EM drive control signal (A)
	2	COMDNB	O	0/24 V DC (pulse)	EM drive control signal (_B)
	3	COMDNA	O	0/24 V DC (pulse)	EM drive control signal (_A)
	4	COMDB	O	0/24 V DC (pulse)	EM drive control signal (B)
YC18 Connected to the power source PWB and safety switch 1/2	1	+5VSL	I	5 V DC	5 V DC input from PSPWB
	2	+24VSL	I	24 V DC	24 V DC power input from PSPWB
	3	GND	-	-	Ground
	4	+24VIL1_IN	I	24 V DC	24 V DC power input from SSW1
	5	+24VIL1_OUT	O	24 V DC	24 V DC power output to SSW2
	6	GND	-	-	Ground
	7	+24VIL2	I	24 V DC	24 V DC power input from SSW2
YC19 Connected to the power source PWB and relay PWB	1	SLEEPN	I	0/5 V DC	Sleep signal: On/Off
	2	ZCROSSC	I	0/5 V DC (pulse)	Zero-cross signal
	3	GND	-	-	Ground
	4	FAN3DRN	O	0/24 V DC	CFM3: On/Off
	5	SHEATN	O	0/5 V DC	FH-S: On/Off
	6	MHEATN	O	0/5 V DC	FH-M: On/Off
	7	+24VSL	I	24 V DC	24 V DC power input from PSPWB
	8	HRELAY	I	0/5 V DC	RELAY signal
	9	NC	-	-	Not used
YC20 Connected to the key counter	1	+24VSL	O	24 V DC	24 V DC power output to key counter
	2	KEYCN	O	0/5 V DC	Key counter signal
	3	SGND	-	-	Ground
	4	KEYENBN	I	0/5 V DC	Key counter connection signal
	5	+5VSL	O	5 V DC	5 V DC power output to key counter
YC22 Connected to the paper size length switch 1/2, optional paper feeder and MP feed switch	1	+24VIL2PF2	O	24 V DC	24 V DC power output to PWSW2
	2	+24VIL2PF1	O	24 V DC	24 V DC power output to PWSW1
	3	+24VIL2	O	24 V DC	24 V DC power output to PWSW2
	4	+24VIL2	O	24 V DC	24 V DC power output to PWSW1
	5	LODIG1	I	0/5 V DC	PWSW2: On/Off
	6	HIDIG1	I	0/5 V DC	PWSW1: On/Off
	7	LODIG0	I	0/5 V DC	PWSW2: On/Off
	8	HIDIG0	I	0/5 V DC	PWSW1: On/Off
	9	GND	-	-	Ground
	10	GND	-	-	Ground
	11	LODIG2	I	0/5 V DC	PWSW2: On/Off
	12	HIDIG2	I	0/5 V DC	PWSW1: On/Off
	13	GND	-	-	Ground
	14	+5VSL	O	5 V DC	5 V DC power output to paper feeder
	15	PFSEL	O	0/5 V DC	Paper feeder select signal

Connector	Pin No.	Signal	I/O	Voltage	Description
Connected to the paper size length switch 1/2, optional paper feeder and MP feed switch	16	PFSCCLK	O	0/5 V DC (pulse)	Paper feeder clock signal
	17	PFSDI	I	0/5 V DC (pulse)	Paper feeder serial communication data signal
	18	PFSDO	O	0/5 V DC (pulse)	Paper feeder serial communication data signal
	19	PFREADY	I	0/5 V DC	Paper feeder ready signal
	20	PFFEED	O	0/5 V DC	Paper feeder feed signal
	21	GND	-	-	Ground
	22	BYPFEEDSW	I	0/5 V DC	MPFSW: On/Off
	23	+5VSL	O	5 V DC	5 V DC power output to MPFSW
24	NC	-	-	Not used	
Connected to the lift switch 1/2, paper switch 1/2, lift motor1/2 and paper size length switch 1/2	A1	GND	-	-	Ground
	A2	LOLIFTSW	I	0/5 V DC	LICSW2: On/Off
	A3	+5VSL	O	5 V DC	5 V DC power output to LICSW2
	A4	GND	-	-	Ground
	A5	LOPAPSW	I	0/5 V DC	PSW2: On/Off
	A6	+5VSL	O	5 V DC	5 V DC power output to PSW2
	A7	LOLIFTSW2	I	0/5 V DC	LM2 paper gauge signal
	A8	GND	-	-	Ground
	A9	LOLIFTSW1	I	0/5 V DC	LM2 paper gauge signal
	A10	GND	-	-	Ground
	A11	LOLIFTREM	O	0/24 V DC	LM2: On/Off
	A12	LOLENGSW	I	0/5 V DC	PLSW2: On/Off
	A13	GND	-	-	Ground
	B1	GND	-	-	Ground
	B2	HILENGSW	I	0/5 V DC	PLSW1: On/Off
	B3	HILIFTSW2	I	0/5 V DC	LM1 paper gauge signal
	B4	GND	-	-	Ground
	B5	HILIFTSW1	I	0/5 V DC	LM1 paper gauge signal
	B6	GND	-	-	Ground
	B7	HILIFTREM	O	0/24 V DC	LM1: On/Off
B8	GND	-	-	Ground	
B9	HILIFTSW	I	0/5 V DC	LICSW1: On/Off	
B10	+5VSL	O	5 V DC	5 V DC power output to LICSW1	
B11	GND	-	-	Ground	
B12	HIPAPSW	I	0/5 V DC	PSW1: On/Off	
B13	+5VSL	O	5 V DC	5 V DC power output to PSW1	
Connected to the power source PWB	1	NC	-	-	Not used
	2	NC	-	-	Not used
	3	NC	-	-	Not used
	4	+24VIL3	I	24V DC	24 V DC power input from PSPWB
Connected to the temperature sensor	1	+5VSL	O	5 V DC	5 V DC power output to TEMS
	2	HUMIDA	I	Analog	TEMS detection voltage signal
	3	GND	-	-	Ground
	4	TEMPA	I	Analog	TEMS detection voltage signal
	5	NC	-	-	Not used

Connector	Pin No.	Signal	I/O	Voltage	Description
YC35 Connected to the main PWB	1	EG_SCLK	I	0/3.3 V DC (pulse)	EPWB clock signal
	2	HLD_ENG	I	0/3.3 V DC	EPWB hold signal
	3	EG_SI	I	0/3.3 V DC (pulse)	EPWB serial communication data signal
	4	SLEEPG	I	0/3.3 V DC	Sleep signal: On/Off
	5	GND	-	-	Ground
	6	GND	-	-	Ground
	7	GND	-	-	Ground
	8	VMRED_P	I	0/3.3 V DC (pulse)	Image control signal
	9	GND	-	-	Ground
	10	VMRED_N	I	0/3.3 V DC (pulse)	Image control signal
	11	VCCLK_P	I	0/3.3 V DC (pulse)	MPWB clock signal
	12	VD_D0_P	I	0/3.3 V DC (pulse)	Image control signal
	13	VCCLK_N	I	0/3.3 V DC (pulse)	MPWB clock signal
	14	VD_D0_N	I	0/3.3 V DC (pulse)	Image control signal
	15	GND	-	-	Ground
	16	VD_D1_P	I	0/3.3 V DC (pulse)	Image control signal
	17	GND	-	-	Ground
	18	VD_D1_N	I	0/3.3 V DC (pulse)	Image control signal
	19	GND	-	-	Ground
	20	VD_D2_P	I	0/3.3 V DC (pulse)	Image control signal
	21	GND	-	-	Ground
	22	VD_D2_N	I	0/3.3 V DC (pulse)	Image control signal
	23	GND	-	-	Ground
	24	VD_D3_P	I	0/3.3 V DC (pulse)	Image control signal
	25	GND	-	-	Ground
	26	VD_D3_N	I	0/3.3 V DC (pulse)	Image control signal
	27	HSYNC_DP	O	0/3.3 V DC (pulse)	Image control signal
	28	VSYNC_DP	O	0/3.3 V DC (pulse)	Image control signal
	29	HSYNC_DN	O	0/3.3 V DC (pulse)	Image control signal
	30	VSYNC_DN	O	0/3.3 V DC (pulse)	Image control signal
	31	HSYNC_CP	O	0/3.3 V DC (pulse)	Image control signal
	32	VSYNC_CP	O	0/3.3 V DC (pulse)	Image control signal
	33	HSYNC_CN	O	0/3.3 V DC (pulse)	Image control signal
	34	VSYNC_CN	O	0/3.3 V DC (pulse)	Image control signal
	35	HSYNC_BP	O	0/3.3 V DC (pulse)	Image control signal
	36	VSYNC_BP	O	0/3.3 V DC (pulse)	Image control signal
	37	HSYNC_BN	O	0/3.3 V DC (pulse)	Image control signal
	38	VSYNC_BN	O	0/3.3 V DC (pulse)	Image control signal
	39	HSYNC_AP	O	0/3.3 V DC (pulse)	Image control signal
	40	VSYNC_AP	O	0/3.3 V DC (pulse)	Image control signal
	41	HSYNC_AN	O	0/3.3 V DC (pulse)	Image control signal
	42	VSYNC_AN	O	0/3.3 V DC (pulse)	Image control signal
	43	GND	-	-	Ground
	44	GND	-	-	Ground

Connector	Pin No.	Signal	I/O	Voltage	Description
YC35	45	GND	-	-	Ground
Connected to the main PWB	46	EG_IRN	I	0/3.3 V DC	EPWB interrupt signal
	47	EG_SO	O	0/3.3 V DC (pulse)	EPWB serial communication data signal
	48	EG_SDIR	I	0/3.3 V DC	EPWB communication direction signal
	49	EG_SBSY	I	0/3.3 V DC	EPWB busy signal
	50	24V_OFF	I	0/3.3 V DC	EPWB 24 V down signal
YC36	1	PDN	I	0/3.3 V DC	Laser sync signal
Connected to the LSU	2	SGND	-	-	Ground
	3	OUTPEN	O	0/3.3 V DC	Laser diode output signal
	4	SAMPLEN	O	0/3.3 V DC	Sample hold signal
	5	VDOP	O	-	Image data signal
	6	VDON	O	-	Image data signal
	7	+5VSL	O	5 V DC	5 V DC power output to APCPWB
YC37		FAN5POW	O	24 V DC	24 V DC power output to EFM
Connected to the eject fan motor		FAN5DRN	O	0/24 V DC	EFM: On/Off

2-3-3 Main PWB

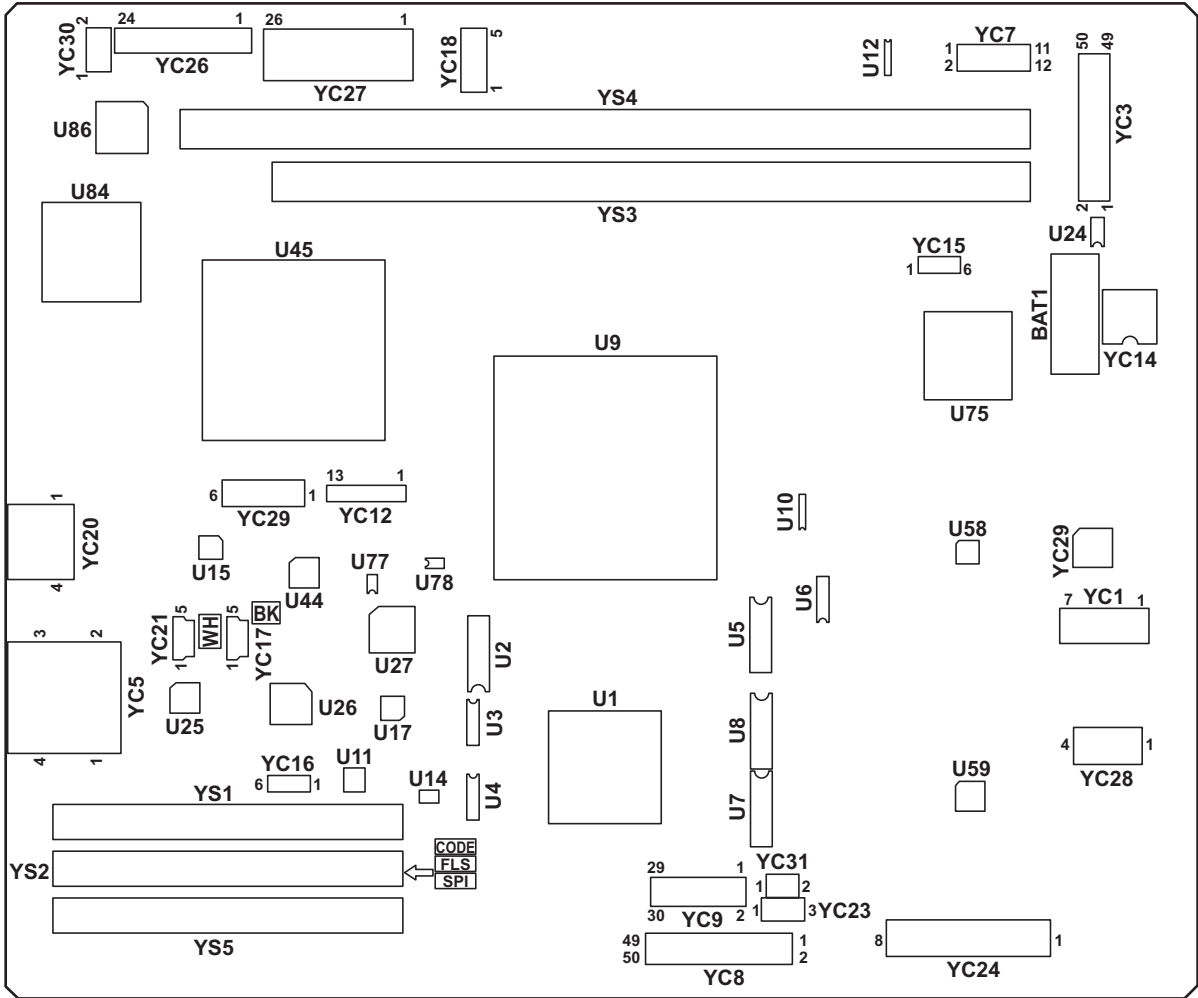

Figure 2-3-3 Main PWB silk-screen diagram

Connector	Pin No.	Signal	I/O	Voltage	Description
YC1 Connected to the hard disk	1	GND	-	-	Ground
	2	TXP	O	0/3.3 V DC (pulse)	Transmission data
	3	TXN	O	0/3.3 V DC (pulse)	Transmission data
	4	GND	-	-	Ground
	5	RXN	I	0/3.3 V DC (pulse)	Received data
	6	RXP	I	0/3.3 V DC (pulse)	Received data
	7	GND	-	-	Ground
YC3 Connected to the main PWB	1	EG_SCLK	O	0/3.3 V DC (pulse)	EPWB clock signal
	2	HLD_ENG	O	0/3.3 V DC	EPWB hold signal
	3	EG_SI	O	0/3.3 V DC (pulse)	EPWB serial communication data signal
	4	SLEEPG	O	0/3.3 V DC	Sleep signal: On/Off
	5	GND	-	-	Ground
	6	GND	-	-	Ground
	7	GND	-	-	Ground
	8	VMRED_P	O	0/3.3 V DC (pulse)	Image control signal
	9	GND	-	-	Ground
	10	VMRED_N	O	0/3.3 V DC (pulse)	Image control signal
	11	VCLK_P	O	0/3.3 V DC (pulse)	MPWB clock signal
	12	VD_D0_P	O	0/3.3 V DC (pulse)	Image control signal
	13	VCLK_N	O	0/3.3 V DC (pulse)	MPWB clock signal
	14	VD_D0_N	O	0/3.3 V DC (pulse)	Image control signal
	15	GND	-	-	Ground
	16	VD_D1_P	O	0/3.3 V DC (pulse)	Image control signal
	17	GND	-	-	Ground
	18	VD_D1_N	O	0/3.3 V DC (pulse)	Image control signal
	19	GND	-	-	Ground
	20	VD_D2_P	O	0/3.3 V DC (pulse)	Image control signal
	21	GND	-	-	Ground
	22	VD_D2_N	O	0/3.3 V DC (pulse)	Image control signal
	23	GND	-	-	Ground
	24	VD_D3_P	O	0/3.3 V DC (pulse)	Image control signal
	25	GND	-	-	Ground
	26	VD_D3_N	O	0/3.3 V DC (pulse)	Image control signal
	27	HSYNC_DP	I	0/3.3 V DC (pulse)	Image control signal
	28	VSYNC_DP	I	0/3.3 V DC (pulse)	Image control signal
	29	HSYNC_DN	I	0/3.3 V DC (pulse)	Image control signal
	30	VSYNC_DN	I	0/3.3 V DC (pulse)	Image control signal
	31	HSYNC_CP	I	0/3.3 V DC (pulse)	Image control signal
	32	VSYNC_CP	I	0/3.3 V DC (pulse)	Image control signal
	33	HSYNC_CN	I	0/3.3 V DC (pulse)	Image control signal
	34	VSYNC_CN	I	0/3.3 V DC (pulse)	Image control signal
	35	HSYNC_BP	I	0/3.3 V DC (pulse)	Image control signal
	36	VSYNC_BP	I	0/3.3 V DC (pulse)	Image control signal

Connector	Pin No.	Signal	I/O	Voltage	Description
YC3 Connected to the main PWB	37	HSYNC_BN	I	0/3.3 V DC (pulse)	Image control signal
	38	VSYNC_BN	I	0/3.3 V DC (pulse)	Image control signal
	39	HSYNC_AP	I	0/3.3 V DC (pulse)	Image control signal
	40	VSYNC_AP	I	0/3.3 V DC (pulse)	Image control signal
	41	HSYNC_AN	I	0/3.3 V DC (pulse)	Image control signal
	42	VSYNC_AN	I	0/3.3 V DC (pulse)	Image control signal
	43	GND	-	-	Ground
	44	GND	-	-	Ground
	45	GND	-	-	Ground
	46	EG_IRN	O	0/3.3 V DC	EPWB interrupt signal
	47	EG_SO	I	0/3.3 V DC (pulse)	EPWB serial communication data signal
	48	EG_SDIR	O	0/3.3 V DC	EPWB communication direction signal
	49	EG_SBSY	O	0/3.3 V DC	EPWB busy signal
50	24V_OFF	O	0/3.3 V DC	EPWB 24 V down signal	
YC5-1 Connected to the ether- net	1	CT	O	3.3 V DC	3.3 V DC power output
	2	TD+	O	0/3.3 V DC (pulse)	Transmission data
	3	TD-	O	0/3.3 V DC (pulse)	Transmission data
	4	RD+	I	0/3.3 V DC (pulse)	Received data
	5	RD-	I	0/3.3 V DC (pulse)	Received data
	6	CT	O	3.3 V DC	3.3 V DC power output
	7	CAT PHY	O	0/3.3 V DC	Control signal
	8	ANO PHY	O	3.3 V DC	3.3 V DC power output
	9	CAT MAC	-	-	Ground
	10	ANO MAC	O	0/3.3 V DC	Control signal
YC5-2 Connected to the USB	U1	VBUS	I	5 V DC	5 V DC power input
	U2	DATA-	I/O	-	USB data signal
	U3	DATA+	I/O	-	USB data signal
	U4	GND	-	-	Ground
YC8 Connected to the inter- face PWB	1	GND	-	-	Ground
	2	AUDIO	I	Analog	AUDIO signal
	3	SEL AUDIO0	O	0/3.3 V DC	SEL AUDIO0 signal
	4	SEL AUDIO1	O	0/3.3 V DC	SEL AUDIO1 signal
	5	_REG	I	0/3.3 V DC	REG signal
	6	A8	O	0/3.3 V DC (pulse)	Address bus signal
	7	A15	O	0/3.3 V DC (pulse)	Address bus signal
	8	A7	O	0/3.3 V DC (pulse)	Address bus signal
	9	A14	O	0/3.3 V DC (pulse)	Address bus signal
	10	A6	O	0/3.3 V DC (pulse)	Address bus signal
	11	A13	O	0/3.3 V DC (pulse)	Address bus signal
	12	A5	O	0/3.3 V DC (pulse)	Address bus signal
	13	A12	O	0/3.3 V DC (pulse)	Address bus signal
	14	A4	O	0/3.3 V DC (pulse)	Address bus signal
	15	A11	O	0/3.3 V DC (pulse)	Address bus signal

Connector	Pin No.	Signal	I/O	Voltage	Description
YC8 Connected to the inter- face PWB	16	A3	O	0/3.3 V DC (pulse)	Address bus signal
	17	A10	O	0/3.3 V DC (pulse)	Address bus signal
	18	A2	O	0/3.3 V DC (pulse)	Address bus signal
	19	A9	O	0/3.3 V DC (pulse)	Address bus signal
	20	A1	O	0/3.3 V DC (pulse)	Address bus signal
	21	GND	-	-	Ground
	22	GND	-	-	Ground
	23	D8	I/O	0/3.3 V DC (pulse)	Data bus signal
	24	D0	I/O	0/3.3 V DC (pulse)	Data bus signal
	25	D9	I/O	0/3.3 V DC (pulse)	Data bus signal
	26	D1	I/O	0/3.3 V DC (pulse)	Data bus signal
	27	D10	I/O	0/3.3 V DC (pulse)	Data bus signal
	28	D2	I/O	0/3.3 V DC (pulse)	Data bus signal
	29	D11	I/O	0/3.3 V DC (pulse)	Data bus signal
	30	D3	I/O	0/3.3 V DC (pulse)	Data bus signal
	31	GND	-	-	Ground
	32	GND	-	-	Ground
	33	D12	I/O	0/3.3 V DC (pulse)	Data bus signal
	34	D4	I/O	0/3.3 V DC (pulse)	Data bus signal
	35	D13	I/O	0/3.3 V DC (pulse)	Data bus signal
	36	D5	I/O	0/3.3 V DC (pulse)	Data bus signal
	37	D14	I/O	0/3.3 V DC (pulse)	Data bus signal
	38	D6	I/O	0/3.3 V DC (pulse)	Data bus signal
	39	D15	I/O	0/3.3 V DC (pulse)	Data bus signal
	40	D7	I/O	0/3.3 V DC (pulse)	Data bus signal
	41	GND	-	-	Ground
	42	GND	-	-	Ground
	43	KUIODREQT0	I	0/3.3 V DC (pulse)	KUIODREQT0 signal
	44	KUIODREQT1	I	0/3.3 V DC (pulse)	KUIODREQT1 signal
	45	KUIODREQR0	I	0/3.3 V DC (pulse)	KUIODREQR0 signal
	46	KUIODREQR1	I	0/3.3 V DC (pulse)	KUIODREQR1 signal
	47	KUIOIORN0	O	0/3.3 V DC (pulse)	KUIOIORN0 signal
	48	KUIOIORN1	O	0/3.3 V DC (pulse)	KUIOIORN1 signal
49	KUIOIOWN0	O	0/3.3 V DC (pulse)	KUIOIOWN0 signal	
50	KUIOIOWN1	O	0/3.3 V DC (pulse)	KUIOIOWN1 signal	

Connector	Pin No.	Signal	I/O	Voltage	Description
YC9 Connected to the interface PWB	1	KUIOCSN0	O	0/3.3 V DC (pulse)	KUIOCSN0 signal
	2	KUIOCSN1	O	0/3.3 V DC (pulse)	KUIOCSN1 signal
	3	KUIOACKN0	I	0/3.3 V DC (pulse)	KUIOACKN0 signal
	4	KUIOACKN1	I	0/3.3 V DC (pulse)	KUIOACKN1 signal
	5	KUIOIRN0	I	0/3.3 V DC	KUIOIRN0 signal
	6	KUIOIRN1	I	0/3.3 V DC	KUIOIRN1 signal
	7	KUIORDY0	O	0/3.3 V DC	KUIORDY0 signal
	8	KUIORDY1	O	0/3.3 V DC	KUIORDY1 signal
	9	GND	-	-	Ground
	10	GND	-	-	Ground
	11	KUIODACKRN0	O	0/3.3 V DC (pulse)	KUIODACKRN0 signal
	12	KUIODACKRN1	O	0/3.3 V DC (pulse)	KUIODACKRN1 signal
	13	KUIODACKTN0	O	0/3.3 V DC (pulse)	KUIODACKTN0 signal
	14	KUIODACKTN1	O	0/3.3 V DC (pulse)	KUIODACKTN1 signal
	15	KUIORSTN0	O	0/3.3 V DC	KUIORSTN0 signal
	16	KUIORSTN1	O	0/3.3 V DC	KUIORSTN1 signal
	17	GND	-	-	Ground
	18	GND	-	-	Ground
	19	SLEEP	O	0/3.3 V DC	SLEEP signal
	20	CFOEN0	O	0/3.3 V DC (pulse)	CFOEN0 signal
	21	EXTBOEN	O	0/3.3 V DC (pulse)	EXTBOEN signal
	22	CFWEN0	O	0/3.3 V DC (pulse)	CFWEN0 signal
	23	EXTBDIR	O	0/3.3 V DC (pulse)	EXTBDIR signal
	24	CFRST0	O	0/3.3 V DC	CFRST0 signal
	25	CF0CSN0	O	0/3.3 V DC (pulse)	CF0CSN0 signal
	26	CFWAITN0	I	0/3.3 V DC	CFWAITN0 signal
	27	CF0CSN1	O	0/3.3 V DC (pulse)	CF0CSN1 signal
	28	CF0CDT1	I	0/3.3 V DC	CF0CDT1 signal
	29	GND	-	-	Ground
	30	CF0CDT2	I	0/3.3 V DC	CF0CDT2 signal
YC12 Connected to the main operation PWB	1	FPSTAT	I	0/3.3 V DC	Operation panel status signal
	2	S LED0	O	0/3.3 V DC	Operation panel LED display signal
	3	S LED1	O	0/3.3 V DC	Operation panel LED display signal
	4	PANEL RESET	O	0/3.3 V DC	OPWB-M reset signal
	5	HLD PANEL	O	0/3.3 V DC	Operation panel displaying enable signal
	6	SW FOOTN	-	-	Not used
	7	+24V DOWN	O	0/3.3 V DC	24 V DC down signal
	8	SUPND ENTER	O	0/3.3 V DC	Energy save mode control signal
	9	AUDIO	O	Analog	Audio output signal
	10	SGND	-	-	Ground
	11	PH KEY	I	0/3.3 V DC	Power key: On/Off
	12	SGND	-	-	Ground
	13	SUPND POWER	O	5 V DC	5 V DC power to OPWB-M

Connector	Pin No.	Signal	I/O	Voltage	Description
YC17 Connected to the main operation PWB	1	VBUS	I	5 V DC	5 V DC power input
	2	DATA-	I/O	-	USB data signal
	3	DATA+	I/O	-	USB data signal
	4	NC	-	-	Not used
	5	GND	-	-	Ground
YC20 Connected to the USB	U1	VBUS	O	5 V DC	5 V DC power output
	U2	DATA-	I/O	-	USB data signal
	U3	DATA+	I/O	-	USB data signal
	U4	GND	-	-	Ground
YC21 Connected to the USB	1	VBUS	O	5 V DC	5 V DC power output
	2	DATA-	I/O	-	USB data signal
	3	DATA+	I/O	-	USB data signal
	4	NC	-	-	Not used
	5	GND	-	-	Ground
YC23 Connected to the controller fan motor	1	CTL FAN	O	0/5 V DC	CONFM: On/Off
	2	GND	-	-	Ground
	3	+5V	O	5 V DC	5 V DC power output to CONFM
YC24 Connected to the power source PWB	1	+5V	I	5 V DC	5 V DC power input from PSPWB
	2	+5V	I	5 V DC	5 V DC power input from PSPWB
	3	+5VSL	I	5 V DC	5 V DC power input from PSPWB
	4	+12VSL	I	5 V DC	5 V DC power input from PSPWB
	5	GND	-	-	Ground
	6	GND	-	-	Ground
	7	GND	-	-	Ground
	8	GND	-	-	Ground
YC25 Connected to the interface PWB	1	+5V	O	5 V DC	5 V DC power output to IFPWB
	2	GND	-	-	Ground
YC26 Connected to the CCD PWB	1	+10VSL	O	10 V DC	10 V DC power output to CCDPWB
	2	+10VSL	O	10 V DC	10 V DC power output to CCDPWB
	3	OS1_BO	I	Analog	CCD output signal
	4	GND	-	-	Ground
	5	OS2_BE	I	Analog	CCD output signal
	6	GND	-	-	Ground
	7	OS3_GO	I	Analog	CCD output signal
	8	GND	-	-	Ground
	9	OS4_GE	I	Analog	CCD output signal
	10	GND	-	-	Ground
	11	OS5_RO	I	Analog	CCD output signal
	12	GND	-	-	Ground
	13	OS6_RE	I	Analog	CCD output signal

Connector	Pin No.	Signal	I/O	Voltage	Description
YC26 Connected to the CCD PWB	14	+5VSL	O	5 V DC	5 V DC power output to CCDPWB
	15	+5VSL	O	5 V DC	5 V DC power output to CCDPWB
	16	+5VSL	O	5 V DC	5 V DC power output to CCDPWB
	17	CCDSH	O	0/3.3 V DC	CCD control signal
	18	GND	-	-	Ground
	19	CCDRS	O	0/3.3 V DC	CCD control signal
	20	GND	-	-	Ground
	21	CCDCP	O	0/3.3 V DC	CCD control signal
	22	GND	-	-	Ground
	23	CCDCLK1	O	0/3.3 V DC (pulse)	CCD clock signal
	24	+3.3VSL	O	3.3 V DC	3.3 V DC power output to CCDPWB
YC27 Connected to the scan- ner PWB	1	+5VSL	O	5 V DC	5 V DC power output to SPWB
	2	+5VSL	O	5 V DC	5 V DC power output to SPWB
	3	GND	-	-	Ground
	4	GND	-	-	Ground
	5	GND	-	-	Ground
	6	GND	-	-	Ground
	7	SLEEP	O	0/3.3 V DC	Sleep signal
	8	GA_SO	O	0/3.3 V DC (pulse)	Serial communication data signal
	9	GA_SRDY	O	0/3.3 V DC (pulse)	Ready signal
	10	GA_OVM	O	0/3.3 V DC	Control signal
	11	GA_SI	I	0/3.3 V DC (pulse)	Serial communication data signal
	12	GA_SEL	I	0/3.3 V DC	Select signal
	13	GA_SCLK	I	0/3.3 V DC (pulse)	Clock signal
	14	PAGESTART	I	0/3.3 V DC	SPWB control signal
	15	GND	-	-	Ground
	16	SC_RESN	I	0/3.3 V DC	SPWB reset signal
	17	SC_SCLK	O	0/3.3 V DC (pulse)	SPWB clock signal
	18	SC_SI	O	0/3.3 V DC (pulse)	SPWB serial communication data signal
	19	SC_SO	I	0/3.3 V DC (pulse)	SPWB serial communication data signal
	20	SC_SBSY	I	0/3.3 V DC	SPWB busy signal
	21	SC_SDIR	I	0/3.3 V DC	SPWB communication direction signal
	22	SC_IRN	I	0/3.3 V DC	SPWB interrupt signal
	23	HLD_ScnN	O	0/3.3 V DC	SPWB scanner hold signal
	24	CON10V	I	0/3.3 V DC	SPWB control signal
	25	+3.3VSL	O	3.3 V DC	3.3 V DC power output to SPWB
	26	GND	-	-	Ground
YC28 Connected to the hard disk	1	+12VSL	O	12 V DC	12 V DC power output to HDD
	2	GND	-	-	Ground
	3	+5VSL	O	5 V DC	5 V DC power output to HDD
	4	GND	-	-	Ground

Connector	Pin No.	Signal	I/O	Voltage	Description
YC29	1	+12VSL	O	12 V DC	12 V DC power output to OPWB-M
Connected to the main operation unit PWB	2	+5V	O	5 V DC	5 V DC power output to OPWB-M
	3	+5V	O	5 V DC	5 V DC power output to OPWB-M
	4	GND	-	-	Ground
	5	GND	-	-	Ground
	6	GND	-	-	Ground

2-3-4 Scanner PWB

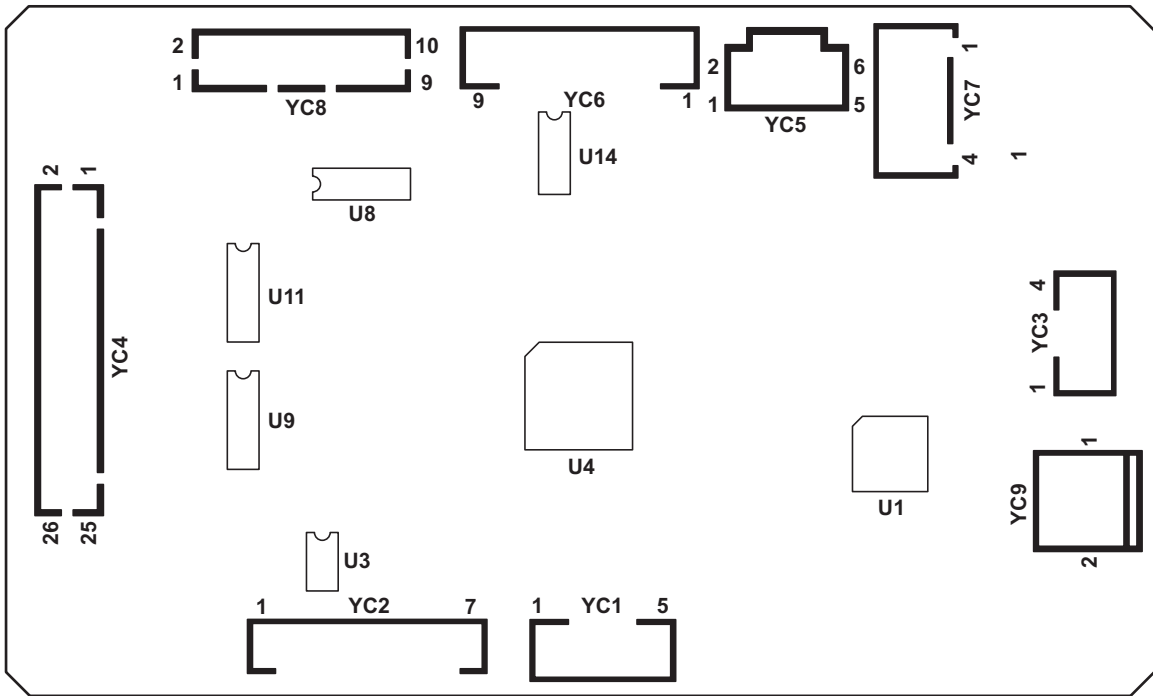

Figure 2-3-4 Scanner PWB silk-screen diagram

Connector	Pin No.	Signal	I/O	Voltage	Description
YC3 Connected to the scan- ner motor	1	SMOTA	O	0/24 V DC (pulse)	SM drive control signal (A)
	2	SMOTB	O	0/24 V DC (pulse)	SM drive control signal (B)
	3	SMOTA_	O	0/24 V DC (pulse)	SM drive control signal (_A)
	4	SMOTB_	O	0/24 V DC (pulse)	SM drive control signal (_B)
YC4 Connected to the main PWB	1	+5VSL	I	5 V DC	5 V DC power input from MPWB
	2	+5VSL	I	5 V DC	5 V DC power input from MPWB
	3	GND	-	-	Ground
	4	GND	-	-	Ground
	5	GND	-	-	Ground
	6	GND	-	-	Ground
	7	SLEEP	I	0/3.3 V DC	Sleep signal
	8	GA_SO	I	0/3.3 V DC (pulse)	Serial communication data signal
	9	GA_SRDY	I	0/3.3 V DC (pulse)	Ready signal
	10	GA_OVM	I	0/3.3 V DC	Control signal
	11	GA_SI	O	0/3.3 V DC (pulse)	Serial communication data signal
	12	GA_SEL	O	0/3.3 V DC	Select signal
	13	GA_SCLK	O	0/3.3 V DC (pulse)	Clock signal
	14	PAGESTART	O	0/3.3 V DC	SPWB control signal
	15	GND	-	-	Ground
	16	SC_RESN	O	0/3.3 V DC	SPWB reset signal
	17	SC_SCLK	I	0/3.3 V DC (pulse)	SPWB clock signal
	18	SC_SI	I	0/3.3 V DC (pulse)	SPWB serial communication data signal
	19	SC_SO	O	0/3.3 V DC (pulse)	SPWB serial communication data signal
	20	SC_SBSY	O	0/3.3 V DC	SPWB busy signal
	21	SC_SDIR	O	0/3.3 V DC	SPWB communication direction signal
	22	SC_IRN	O	0/3.3 V DC	SPWB interrupt signal
	23	HLD_ScnN	I	0/3.3 V DC	SPWB scanner hold signal
	24	CON10V	O	0/3.3 V DC	SPWB control signal
	25	+3.3VSL	I	3.3 V DC	3.3 V DC power input from MPWB
	26	GND	-	-	Ground
YC5 Connected to the inverter PWB	1	LAMPN	O	0/24 V DC	EL: On/Off
	2	PGND	-	-	Ground
	3	+24VSL	O	24 V DC	24 V DC power output to INPWB
	4	+24VSL	O	24 V DC	24 V DC power output to INPWB
	5	PGND	-	-	Ground
	6	LAMPN	O	0/24 V DC	EL: On/Off

Connector	Pin No.	Signal	I/O	Voltage	Description
YC6 Connected to the home position switch, original detection switch and original size sensor	1	+5VSL	O	5 V DC	5 V DC power output to HPSW
	2	HPSWN	I	0/5 V DC	HPSW: On/Off
	3	GND	-	-	Ground
	4	+5VSL	O	5 V DC	5 V DC power output to ODSW
	5	OPSWN	I	0/5 V DC	ODSW: On/Off
	6	GND	-	-	Ground
	7	+5VSL	O	5 V DC	5 V DC power output to OSS
	8	ORGLSWN	I	0/5 V DC	OSS: On/Off
	9	GND	-	-	Ground
YC7 Connected to the optional DP	1	+24VSL	O	24 V DC	24 V DC power output to DP
	2	GND	-	-	Ground
	3	+5VSL	O	5 V DC	5 V DC power output to DP
	4	GND	-	-	Ground
YC8 Connected to the optional DP	1	GND	-	-	Ground
	2	GND	-	-	Ground
	3	GND	-	-	Ground
	4	GND	-	-	Ground
	5	ORGVSYNC	I	0/5 V DC	Original scanning interval signal
	6	DP_RDY	I	0/5 V DC	DP ready signal
	7	DP_SEL	O	0/5 V DC	DP select signal
	8	SCLK	O	0/5 V DC (pulse)	DP clock signal
	9	SDO	O	0/5 V DC (pulse)	DP serial communication data signal
	10	SDI	I	0/5 V DC (pulse)	DP serial communication data signal
YC9 Connected to the power source PWB	1	+24VSL	I	24 V DC	24 V DC power input from PSPWB
	2	GND	-	-	Ground

2-3-5 Main operation PWB

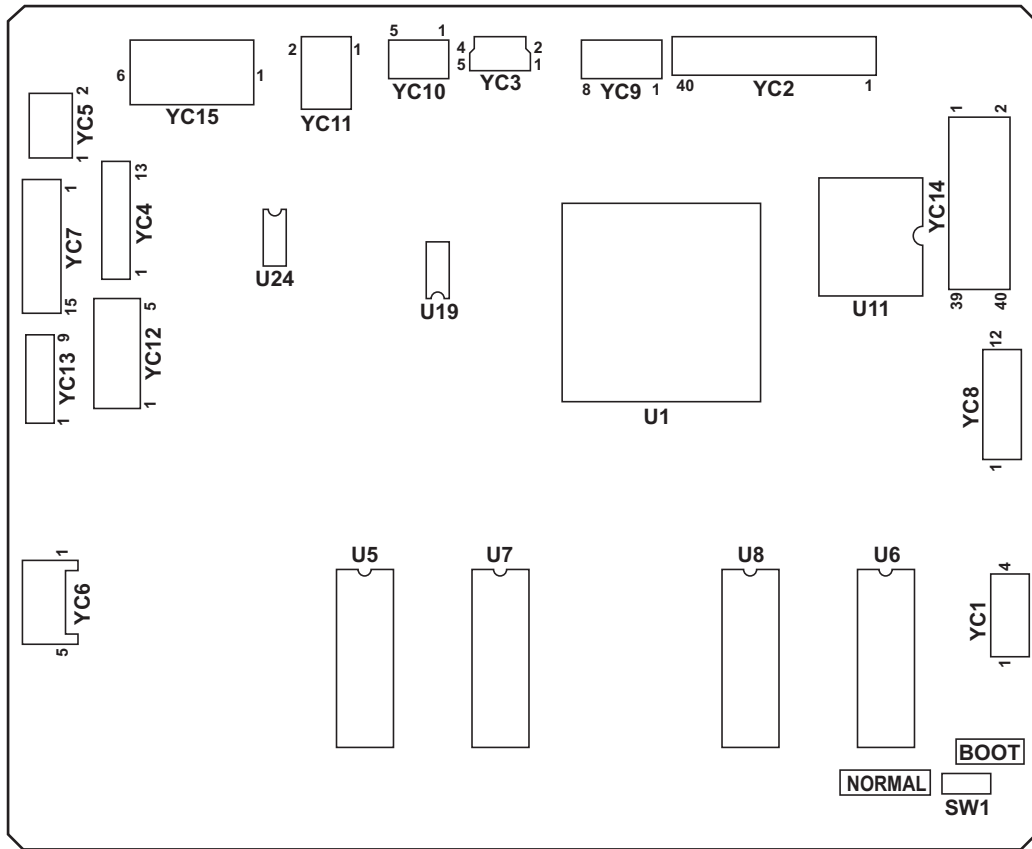

Figure 2-3-5 Main operation PWB silk-screen diagram

Connector	Pin No.	Signal	I/O	Voltage	Description
YC1 Connected to the touch panel	1	TOP Y+	I	Analog	Touch panel Y+ position signal
	2	LEFT X+	I	Analog	Touch panel X+ position signal
	3	BOT Y-	I	Analog	Touch panel Y- position signal
	4	RIGHT X-	I	Analog	Touch panel X- position signal
YC2 Connected to the LCD	1	SGND	-	-	Ground
	2	SGND	-	-	Ground
	3	B5(MSB)	O	0/3.3 V DC	LCD control signal
	4	B4	O	0/3.3 V DC	LCD control signal
	5	B3	O	0/3.3 V DC	LCD control signal
	6	SGND	-	-	Ground
	7	B2	O	0/3.3 V DC	LCD control signal
	8	B1	O	0/3.3 V DC	LCD control signal
	9	B0(LSB)	O	0/3.3 V DC	LCD control signal
	10	SGND	-	-	Ground
	11	G5(MSB)	O	0/3.3 V DC	LCD control signal
	12	G4	O	0/3.3 V DC	LCD control signal
	13	G3	O	0/3.3 V DC	LCD control signal
	14	SGND	-	-	Ground
	15	G2	O	0/3.3 V DC	LCD control signal
	16	G1	O	0/3.3 V DC	LCD control signal
	17	G0(LSB)	O	0/3.3 V DC	LCD control signal
	18	SGND	-	-	Ground
	19	R5(MSB)	O	0/3.3 V DC	LCD control signal
	20	R4	O	0/3.3 V DC	LCD control signal
	21	R3	O	0/3.3 V DC	LCD control signal
	22	SGND	-	-	Ground
	23	R2	O	0/3.3 V DC	LCD control signal
	24	R1	O	0/3.3 V DC	LCD control signal
	25	R0(LSB)	O	0/3.3 V DC	LCD control signal
	26	SGND	-	-	Ground
	27	DE	O	0/3.3 V DC	LCD control signal
	28	SGND	-	-	Ground
	29	L_R	O	0/3.3 V DC	LCD control signal
	30	U_D	O	0/3.3 V DC	LCD control signal
	31	SGND	-	-	Ground
	32	DCLK	O	0/3.3 V DC (pulse)	LCD clock signal
	33	NC	-	-	Not used
	34	SGND	-	-	Ground
	35	+5V	O	5 V DC	5 V DC power output to LCD
	36	+5V	O	5 V DC	5 V DC power output to LCD
	37	+5V	O	5 V DC	5 V DC power output to LCD
	38	+5V	O	5 V DC	5 V DC power output to LCD
39	SGND	-	-	Ground	
40	SGND	-	-	Ground	

Connector	Pin No.	Signal	I/O	Voltage	Description
YC3 Connected to the main PWB	1	VBUS	I	5 V DC	5 V DC power input
	2	DN	I/O	-	USB data signal
	3	DP	I/O	-	USB data signal
	4	ID	-	-	Not used
	5	GND	-	-	Ground
YC4 Connected to the main PWB	1	SUPND POWER	I	5 V DC	5 V DC power input from MPWB
	2	GND	-	-	Ground
	3	PH KEY	O	0/5 V DC	Power key: On/Off
	4	GND	-	-	Ground
	5	AUDIO	I	Analog	Audio output signal
	6	SUPND_ENTR	I	0/3.3 V DC	Energy save mode control signal
	7	+24V_DOWN	I	0/3.3 V DC	24 V DC down signal
	8	SW_FOOTN	-	-	Not used
	9	HOLDPANEL	I	0/3.3 V DC	Operation panel displaying enable signal
	10	PANEL_RESET	I	0/3.3 V DC	MPWB reset signal
	11	S_LED1	I	0/3.3 V DC	Operation panel LED display signal
	12	S_LED0	I	0/3.3 V DC	Operation panel LED display signal
	13	PANEL_STATU S	O	0/3.3 V DC	Operation panel status signal
YC5 Connected to the operation fan motor	1	5V2	O	5 V DC	5 V DC power output to OFM
	2	FAN REMOTE	O	0/5 V DC	OFM: On/Off
YC6 Connected to the LCD inverter PWB	1	GND	-	-	Ground
	2	+12V	O	12 V DC	12 V DC power output to LINPWB
	3	LCDBKLT	O	0/3.3 V DC	LCD back light: On/Off
	4	ADJUST	O	Analog	LCD back light brightness adjustment signal
	5	GND	-	-	Ground
YC7 Connected to the right operation PWB	1	KEY0	I	0/3.3 V DC (pulse)	Operation panel key scan return signal 0
	2	KEY1	I	0/3.3 V DC (pulse)	Operation panel key scan return signal 1
	3	KEY2	I	0/3.3 V DC (pulse)	Operation panel key scan return signal 2
	4	KEY3	I	0/3.3 V DC (pulse)	Operation panel key scan return signal 3
	5	KEY4	I	0/3.3 V DC (pulse)	Operation panel key scan return signal 4
	6	SCAN0	O	0/3.3 V DC (pulse)	Scan signal 0
	7	SCAN1	O	0/3.3 V DC (pulse)	Scan signal 1
	8	SCAN2	O	0/3.3 V DC (pulse)	Scan signal 2
	9	SCAN3	O	0/3.3 V DC (pulse)	Scan signal 3
	10	SCAN6	O	0/3.3 V DC (pulse)	Scan signal 6
	11	LED0	O	0/3.3 V DC (pulse)	Operation panel LED display drive signal 0
	12	LED1	O	0/3.3 V DC (pulse)	Operation panel LED display drive signal 1
	13	PH KEY	I	0/5 V DC	Power key: On/Off
	14	SUPND POWER	O	5 V DC	5 V DC power output to OPWB-R
	15	GND	-	-	Ground

Connector	Pin No.	Signal	I/O	Voltage	Description
YC8 Connected to the left operation PWB	1	SCAN6	O	0/3.3 V DC (pulse)	Scan signal 6
	2	KEY5	I	0/3.3 V DC (pulse)	Operation panel key scan return signal 5
	3	KEY6	I	0/3.3 V DC (pulse)	Operation panel key scan return signal 6
	4	KEY7	I	0/3.3 V DC (pulse)	Operation panel key scan return signal 7
	5	SCAN0	O	0/3.3 V DC (pulse)	Scan signal 0
	6	SCAN1	O	0/3.3 V DC (pulse)	Scan signal 1
	7	SCAN2	O	0/3.3 V DC (pulse)	Scan signal 2
	8	SCAN3	O	0/3.3 V DC (pulse)	Scan signal 3
	9	LED2	O	0/3.3 V DC (pulse)	Operation panel LED display drive signal 2
	10	LED3	O	0/3.3 V DC (pulse)	Operation panel LED display drive signal 3
	11	LED4	O	0/3.3 V DC (pulse)	Operation panel LED display drive signal 4
	12	GND	-	-	Ground
YC9 Connected to the upper operation PWB	1	SCAN4	O	0/3.3 V DC (pulse)	Scan signal 4
	2	SCAN5	O	0/3.3 V DC (pulse)	Scan signal 5
	3	LED5	O	0/3.3 V DC (pulse)	Operation panel LED display drive signal 5
	4	LED6	O	0/3.3 V DC (pulse)	Operation panel LED display drive signal 6
	5	LED7	O	0/3.3 V DC (pulse)	Operation panel LED display drive signal 7
	6	S_LED0	O	0/5 V DC	Operation panel LED display drive signal 0
	7	S_LED1	O	0/5 V DC	Operation panel LED display drive signal 1
	8	GND	-	-	Ground
YC10 Connected to the front operation PWB	1	SCAN5	O	0/3.3 V DC (pulse)	Scan signal 5
	2	LED5	O	0/3.3 V DC (pulse)	Operation panel LED display drive signal 5
	3	LED6	O	0/3.3 V DC (pulse)	Operation panel LED display drive signal 6
	4	S_LED1	O	0/5 V DC	Operation panel LED display drive signal 1
	5	GND	-	-	Ground
YC11 Connected to the speaker	1	VO2	O	Analog	Speaker sound signal (+)
	2	VO1	O	Analog	Speaker sound signal (-)
YC15 Connected to the power source PWB	1	GND	-	-	Ground
	2	GND	-	-	Ground
	3	GND	-	-	Ground
	4	+5V	I	5 V DC	5 V DC power input from PSPWB
	5	+5V	I	5 V DC	5 V DC power input from PSPWB
	6	+12V	I	12 V DC	12 V DC power input from PSPWB

This page is intentionally left blank.

Maintenance parts list

Maintenance part name		Part No.	Alternative part No.
Name used in service manual	Name used in parts list		
Paper feed pulley	PULLEY,PAPER FEED	2AR07220	-
Separation pulley	PULLEY,SEPARATION	2AR07230	-
Forwarding pulley	PULLEY FEED A	2BJ06010	-
MP paper feed pulley	UPPER PULLEY,BYPASS	61706770	-
MP separation pulley	PULLEY,SEPARATION	2AR07230	-
MP forwarding pulley	PULLEY FEED A	2BJ06010	-
MP feed roller 1	PARTS ROLLER MPF FEED A SP	302H094110	2H094110
MP feed roller 2	PARTS ROLLER MPF FEED B SP	302H094120	2H094120
MP feed pulley	PULLEY 15 MPF FEED	302H008220	2H008220
Left registration roller	PARTS ROLLER REGIST LEFT SP	302H094140	2H094140
Right registration roller	ROLLER REGIST RIGHT	302H024020	2H024020
Feed pulley	PULLEY 15 DUPLEX	3HY07120	-
Feed roller 1	PARTS PULLEY MID FEED ASSY SP	302H094431	2H094431
Feed roller 2	PARTS ROLLER VERTICAL FEED A	302H094091	2H094091
Feed roller 3	PARTS ROLLER VERTICAL FEED B	302H094101	2H094101
Registration cleaner	SPONGE CLEANER REG	302H024240	2H024240
Contact glass	CONTACT GLASS	2C912250	-
Slit glass	CONTACT GLASS ADF	2C912280	-
Mirror 1	MIRROR A	302K517030	2K517030
Mirror 2 and mirror 3	MIRROR B	302KK17330	2KK17330
Reflector	REFLECTOR SCANNER	302H017100	2H017100
Exposure lamp	PARTS LAMP SCANNER W SP	302H094130	2H094130
Original size sensor	SENSOR ORIGINAL	302H044110	2H044110
Transfer roller unit	PARTS TR-670	302H093051	2H093051
Separation electrode	PLATE STA ELIMINATION	2FT17030	-
Developing unit	PARTS,DV-420,SP	302FT93053	2FT93053
Drum unit	PARTS DK-670	302H093012	2H093012
Fuser unit	PARTS FK-671(E)	302K593070	2K593070
Fuser unit	PARTS FK-670(U)	302K593060	2K593060
Heat roller	PARTS ROLLER HEAT SP	302H094160	2H094160
Press roller	PARTS ROLLER PRESS SP	302H094451	2H094451
Heat roller separation claw	SEPARATOR /40301P0028 A4	5MVX222XN002	2A820530
Eject roller	PARTS ROLLER EXIT INNER SP	302H094370	2H094370
Switchback roller	PARTS ROLLER EXIT FEED SP	302H094360	2H094360
Eject pulley	PULLEY EXIT B	2BL21450	-
Feed pulley	PULLEY EXIT FEED	302H028230	2H028230
Upper duplex feed roller	PARTS DUPLEX A SP	302H094380	2H094380
Lower duplex feed roller	PARTS DUPLEX B SP	302H094390	2H094390
Duplex feed pulley	PULLEY 15 DUPLEX	3HY07120	-
Right filter	PARTS HOLDER FILTER A SP	302H094401	2H094401
Ozone filter 1	FILTER OZONE B	302H033180	2H033180
Ozone filter 2	FILTER OZONE A	302H033170	2H033170

Maintenance kits

Maintenance part name		Part No.	Alternative part No.
Name used in service manual	Name used in parts list		
Maintenance kit <For 120 V specifications>	MK-671/MAINTENANCE KIT	1702K57US0	02K57US0
Upper/lower paper feed pulley	PULLEY,PAPER FEED	-	-
Upper/lower separation pulley	PULLEY,SEPARATION	-	-
MP separation pulley	PULLEY,SEPARATION	-	-
Upper/lower forwarding pulley	PULLEY FEED A	-	-
MP forwarding pulley	PULLEY FEED A	-	-
Developing unit	PARTS,DV-420,SP	-	-
Ozone filter 1	FILTER OZONE B	-	-
Ozone filter 2	FILTER OZONE A	-	-
Drum unit	PARTS DK-670	-	-
Fuser unit	PARTS FK-671(U)	-	-
Transfer roller unit	PARTS TR-670	-	-
Right filter	PARTS HOLDER FILTER A SP	-	-
MP paper feed pulley	UPPER PULLEY,BYPASS	-	-
<For 220 - 240 V specifications>	MK-671/MAINTENANCE KIT	1702K58NLO	02K58NLO
Upper/lower paper feed pulley	PULLEY,PAPER FEED	-	-
Upper/lower separation pulley	PULLEY,SEPARATION	-	-
MP separation pulley	PULLEY,SEPARATION	-	-
Upper/lower forwarding pulley	PULLEY FEED A	-	-
MP forwarding pulley	PULLEY FEED A	-	-
Developing unit	PARTS,DV-420,SP	-	-
Ozone filter 1	FILTER OZONE B	-	-
Ozone filter 2	FILTER OZONE A	-	-
Drum unit	PARTS DK-670	-	-
Fuser unit	PARTS FK-671(E)	-	-
Transfer roller unit	PARTS TR-670	-	-
Right filter	PARTS HOLDER FILTER A SP	-	-
MP paper feed pulley	UPPER PULLEY,BYPASS	-	-

Periodic maintenance procedures

Section	Maintenance part/location	User call	300K	Points and cautions	Page
Test copy and test print	Perform at the maximum copy size	Test copy	Test copy		



Section	Maintenance part/location	User call	300K	Points and cautions	Page
Paper feed section	Paper feed pulley	Check Clean	Replace	Clean with alcohol. Replace after feeding 300,000 sheets.	P.1-5-3
	Separation pulley	Check Clean	Replace	Clean with alcohol. Replace after feeding 300,000 sheets.	P.1-5-3
	Forwarding pulley	Check Clean	Replace	Clean with alcohol. Replace after feeding 300,000 sheets.	P.1-5-3
	MP paper feed pulley	Check Clean	Replace	Clean with alcohol. Replace after feeding 300,000 sheets.	P.1-5-6
	MP separation pulley	Check Clean	Replace	Clean with alcohol. Replace after feeding 300,000 sheets.	P.1-5-6
	MP forwarding pulley	Check Clean	Replace	Clean with alcohol. Replace after feeding 300,000 sheets.	P.1-5-6
	MP feed roller 1	Check Clean	Clean	Clean with alcohol.	
	MP feed roller 2	Check Clean	Clean	Clean with alcohol.	
	MP feed pulley	Check Clean	Clean	Clean with alcohol.	
	Left registration roller	Check Clean	Clean	Clean with alcohol.	
	Right registration roller	Check Clean	Clean	Clean with alcohol.	
	Feed pulley	Check Clean	Clean	Clean with alcohol.	
	Feed roller 1	Check Clean	Clean	Clean with alcohol.	
	Feed roller 2	Check Clean	Clean	Clean with alcohol.	
	Feed roller 3	Check Clean	Clean	Clean with alcohol.	
Registration cleaner	Check Clean	Clean	Vacuum.		



Section	Maintenance part/location	User call	300K	Points and cautions	Page
Optical section	Contact glass	Clean	Clean	Clean with alcohol and then a dry cloth.	
	Slit glass	Clean	Clean	Clean with a dry cloth (do not clean with a wet cloth or alcohol).	
	Mirror 1	Clean	-	Clean with a wet cloth and then a dry cloth only if black lines appear on the copy image.	
	Mirror 2 and mirror 3	Clean	-	Clean with a wet cloth and then a dry cloth only if black lines appear on the copy image.	
	Lens	Clean	-	Clean with a dry cloth only if black lines appear on the copy image.	
	Reflector	Clean	-	Clean with a dry cloth only if black lines appear on the copy image.	
	Exposure lamp	Check Replace	-	Replace if an image problem occurs.	P.1-5-15
	Optical rail	Check Grease	-	Check noise and shifting and then apply scanner rail grease EM-50L.	
	Original size sensor	Check Clean	-	Clean the sensor emitter and sensor receiver with alcohol or a dry cloth only if there is a problem.	



Section	Maintenance part/location	User call	300K	Points and cautions	Page
Transfer/ separation sections	Transfer roller unit	Check	Replace	Vacuum or clean with a dry cloth. Replace after feeding 300,000 sheets.	P.1-5-36
	Separation electrode	Check Clean	Check Clean	Clean with a cleaning brush.	



Section	Maintenance part/location	User call	300K	Points and cautions	Page
Developing section	Developing unit	Check Replace	Replace	Replace after feeding 300,000 sheets.	P.1-5-35



Section	Maintenance part/location	User call	300K	Points and cautions	Page
Main charging/drum section	Drum unit	Check Replace	Replace	Replace after feeding 300,000 sheets.	P.1-5-31



Section	Maintenance part/location	User call	300K	Points and cautions	Page
Fuser section	Fuser unit	Check Replace	Replace	Replace after feeding 300,000 sheets.	P.1-5-37
	Heat roller	Check Replace	-	Replace if a problem occurs.	P.1-5-45
	Press roller	Check Replace	-	Replace if a problem occurs.	P.1-5-41
	Heat roller separation claw	Check Clean Replace	-	Clean with alcohol. Replace if claw is deformed.	P.1-5-40



Section	Maintenance part/location	User call	300K	Points and cautions	Page
Eject section	Eject roller	Check Clean	-	Clean with alcohol.	
	Switchback roller	Check Clean	-	Clean with alcohol.	
	Eject pulley	Check Clean	-	Clean with alcohol.	
	Feed pulley	Check Clean	-	Clean with alcohol.	



Section	Maintenance part/location	User call	300K	Points and cautions	Page
Duplex section	Upper duplex feed roller	Check Clean	-	Clean with alcohol.	
	Lower duplex feed roller	Check Clean	-	Clean with alcohol.	
	Duplex feed pulley	Check	-	Clean with alcohol.	





Section	Maintenance part/location	User call	300K	Points and cautions	Page
Covers	Covers	Clean	Clean	Clean with alcohol or a dry cloth.	
	Original platen	Clean	Clean	Clean with alcohol or a dry cloth.	

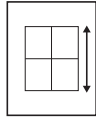
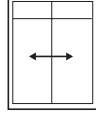
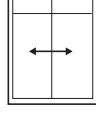
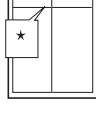
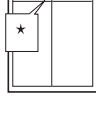
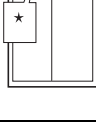

Section	Maintenance part/location	User call	300K	Points and cautions	Page
Other	Right filter	Check Clean	Check Clean	Vacuum.	
	Ozone filter 1	-	Replace	Replace after feeding 300,000 sheets.	P.1-5-51
	Ozone filter 2	-	Replace	Replace after feeding 300,000 sheets.	P.1-5-52
	Image quality	Check Adjust	Check Adjust		

Chart of image adjustment procedures

Adjusting order	Item	Image	Description	Maintenance mode		Original	Page	Remarks
				Item No.	Mode			
1	Adjusting the magnification in the main scanning direction (printing adjustment)		Polygon motor speed adjustment	U053	POLYGON MOTOR	U053 test pattern	P.1-3-26	
2	Adjusting the magnification in the auxiliary scanning direction (printing adjustment)		Drive motor speed adjustment	U053	TMAIN MOTOR	U053 test pattern	P.1-3-26	
3	Adjusting the center line of the MP tray (printing adjustment)		Adjusting the LSU print start timing	U034	LSUOUT LEFT (MPT)	U034 test pattern	P.1-3-23	To make an adjustment for duplex copying, select LSUOUT LEFT (DUP).
4	Adjusting the center line of the cassettes (printing adjustment)		Adjusting the LSU print start timing	U034	LSUOUT LEFT (CAS 1) LSUOUT LEFT (CAS 2) LSUOUT LEFT (CAS 3) LSUOUT LEFT (CAS 4)	U034 test pattern	P.1-3-23	Cassette 1: select Center (Feed 1) Cassette 2: select Center (Feed 2) Cassette 3: select Center (Feed 3) Cassette 4: select Center (Feed 4)
5	Adjusting the leading edge registration of the MP tray (printing adjustment)		Registration motor turning on timing (secondary paper feed start timing)	U034	LSUOUT TOP MPT	U034 test pattern	P.1-3-22	To make an adjustment for duplex copying, select LSUOUT TOP DUP.
6	Adjusting the leading edge registration of the cassette (printing adjustment)		Registration motor turning on timing (secondary paper feed start timing)	U034	LSUOUT TOP CAS	U034 test pattern	P.1-3-22	
7	Adjusting the leading edge margin (printing adjustment)		LSU illumination start timing	U402	LESD	U402 test pattern	P.1-3-71	
8	Adjusting the trailing edge margin (printing adjustment)		LSU illumination end timing	U402	TRAIL	U402 test pattern	P.1-3-71	To make an adjustment for duplex copying, select TRAIL(DUP). To make an adjustment of the MP tray, select TRAIL(MPT).
9	Adjusting the left and right margins (printing adjustment)		LSU illumination start/end timing	U402	A/C	U402 test pattern	P.1-3-71	
10	Adjusting magnification of the scanner in the main scanning direction (scanning adjustment)		Data processing	U065	Y SCAN ZOOM	Test chart	P.1-3-29	No adjustment for copying using the DP.

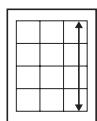
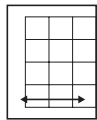
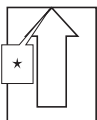
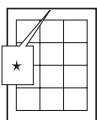
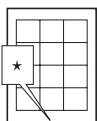
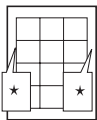
Adjusting order	Item	Image	Description	Maintenance mode		Original	Page	Remarks
				Item No.	Mode			
11	Adjusting magnification of the scanner in the auxiliary scanning direction (scanning adjustment)		Original scanning speed	U065	X SCAN ZOOM	Test chart	P.1-3-29	U065: For copying an original placed on the contact glass U070: For copying originals from the DP. To make an adjustment for duplex copying, select MOTOR ADJ (BACK).
				U070	MOTOR ADJ (FRONT) MOTOR ADJ (BACK)		P.1-3-33	
12	Adjusting the center line (scanning adjustment)		Adjusting the original scan data (image adjustment)	U067	FRONT ROTATE	Test chart	P.1-3-31	U067: For copying an original placed on the contact glass To make an adjustment for rotate copying, select ROTATE. U072: For copying originals from the DP. To make an adjustment for duplex copying, select BACK.
				U072	FRONT BACK		P.1-3-36	
13	Adjusting the leading edge registration (scanning adjustment)		Original scan start timing	U066	FRONT TAIL	Test chart	P.1-3-30	U066: For copying an original placed on the contact glass To make an adjustment for trailing edge registration, select TAIL. U071: For copying originals from the DP. To make an adjustment for duplex copying, select BACK HEAD.
				U071	FRONT HEAD BACK HEAD		P.1-3-34	
14	Adjusting the leading edge margin (scanning adjustment)		Adjusting the original scan data (image adjustment)	U403	B MARGIN	Test chart	P.1-3-72	U403: For copying an original placed on the contact glass U404: For copying originals from the DP.
				U404	B MARGIN		P.1-3-73	
15	Adjusting the trailing edge margin (scanning adjustment)		Adjusting the original scan data (image adjustment)	U403	D MARGIN	Test chart	P.1-3-72	U403: For copying an original placed on the contact glass U404: For copying originals from the DP.
				U404	D MARGIN		P.1-3-73	
16	Adjusting the left and right margins (scanning adjustment)		Adjusting the original scan data (image adjustment)	U403	A MARGIN C MARGIN	Test chart	P.1-3-72	U403: For copying an original placed on the contact glass U404: For copying originals from the DP.
				U404	A MARGIN C MARGIN		P.1-3-73	

When maintenance item U411 (Automatic adjustment in the scanner) is run using the specified original (P/N 302FZ56990),

the following adjustments are automatically made:

Adjusting the scanner magnification (U065)

Adjusting the scanner leading edge registration (U066)

Adjusting the scanner center line (U067)

When maintenance item U411 (Automatic adjustment in the DP) is run using the specified original (P/N 302AC68243),

the following adjustments are automatically made:

Adjusting the DP magnification (U070)

Adjusting the DP leading edge registration (U071)

Adjusting the DP center line (U072)

Image quality

Item	Specifications
100% magnification	Machine: $\pm 0.8\%$ Using DP: $\pm 1.5\%$
Enlargement/reduction	Machine: $\pm 1.0\%$ Using DP: $\pm 1.5\%$
Lateral squareness	Machine: ± 1.5 mm/375 mm Using DP: ± 3.0 mm/375 mm
Leading edge registration	Cassette: ± 2.5 mm MP tray: ± 2.5 mm Duplex: ± 2.5 mm
Skewed paper feed (left-right difference)	Cassette: 1.5 mm or less MP tray: 1.5 mm or less Duplex: 2.0 mm or less
Lateral image shifting	Cassette: ± 2.0 mm MP tray: ± 2.0 mm Duplex: ± 3.0 mm

Wiring diagram No.1

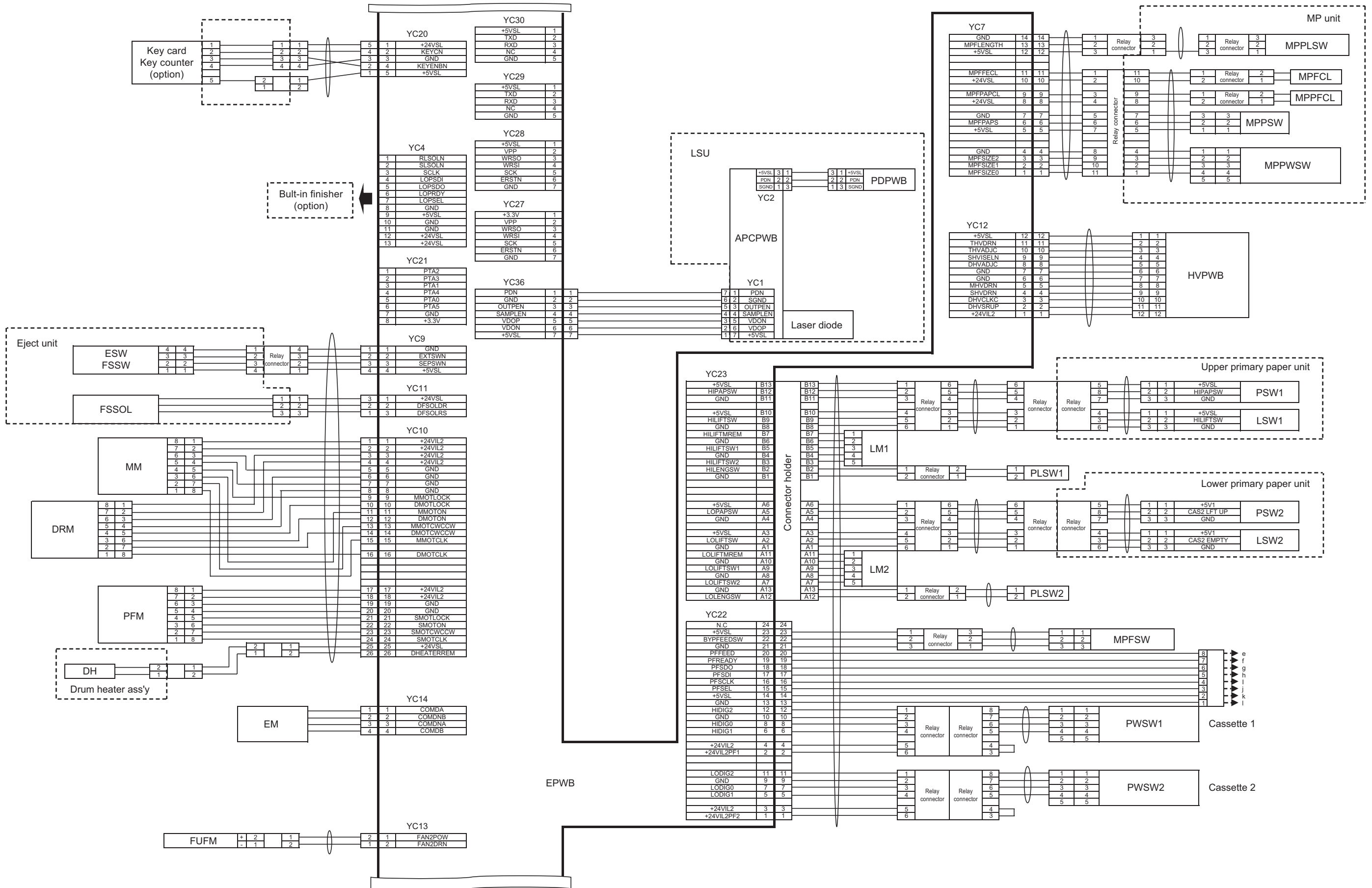

Wiring diagram No.2

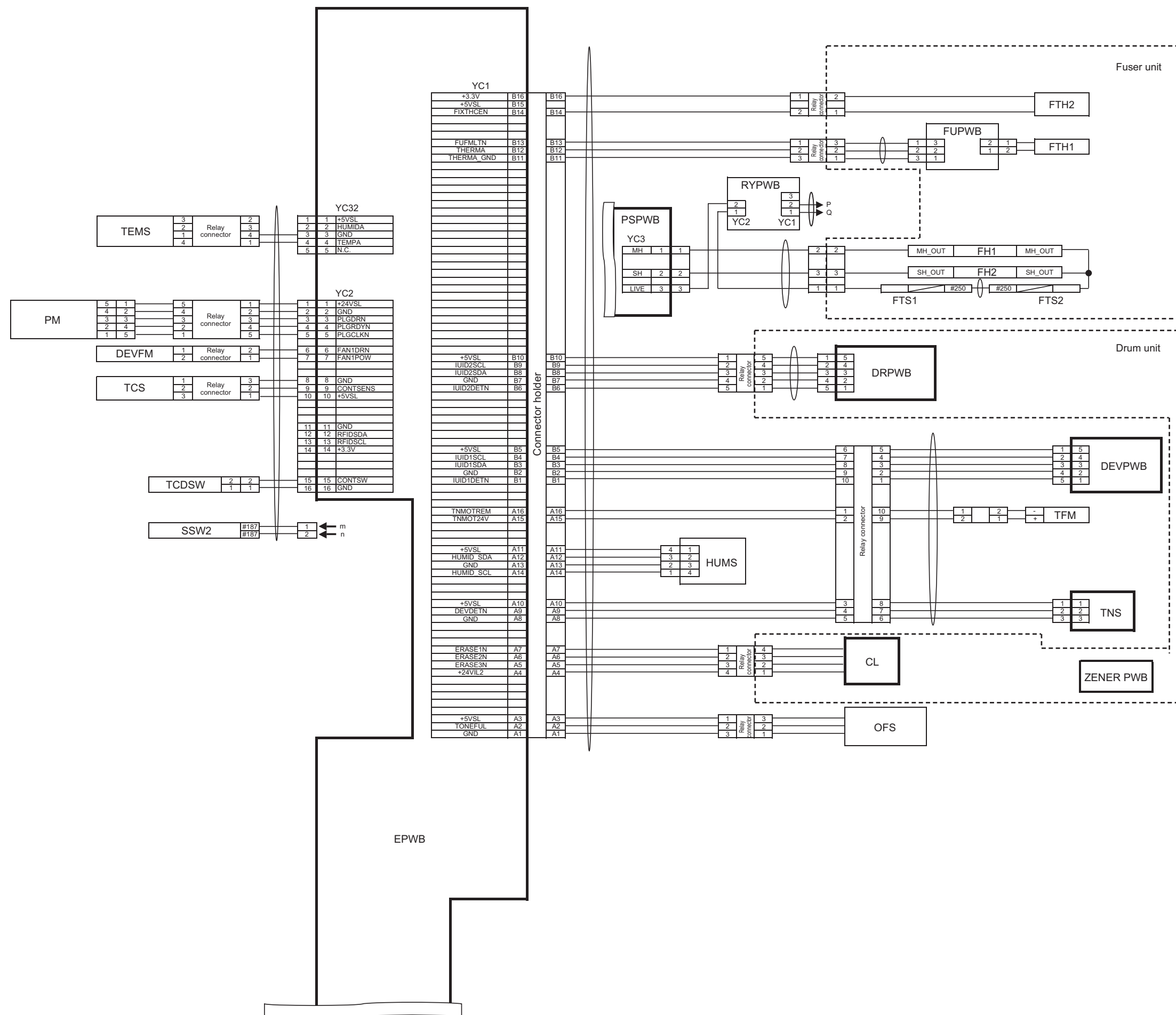

Wiring diagram No.3

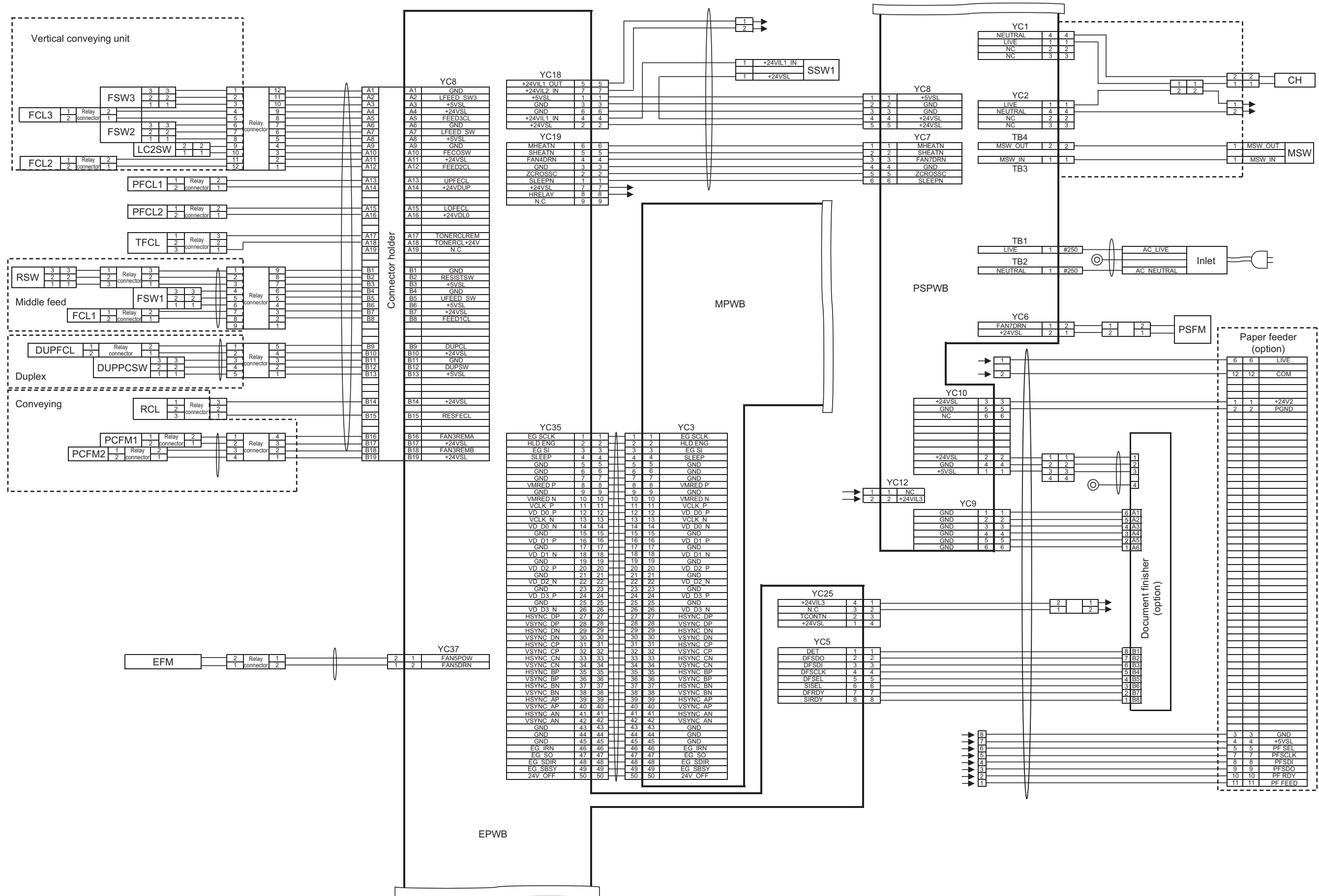

Wiring diagram No.4

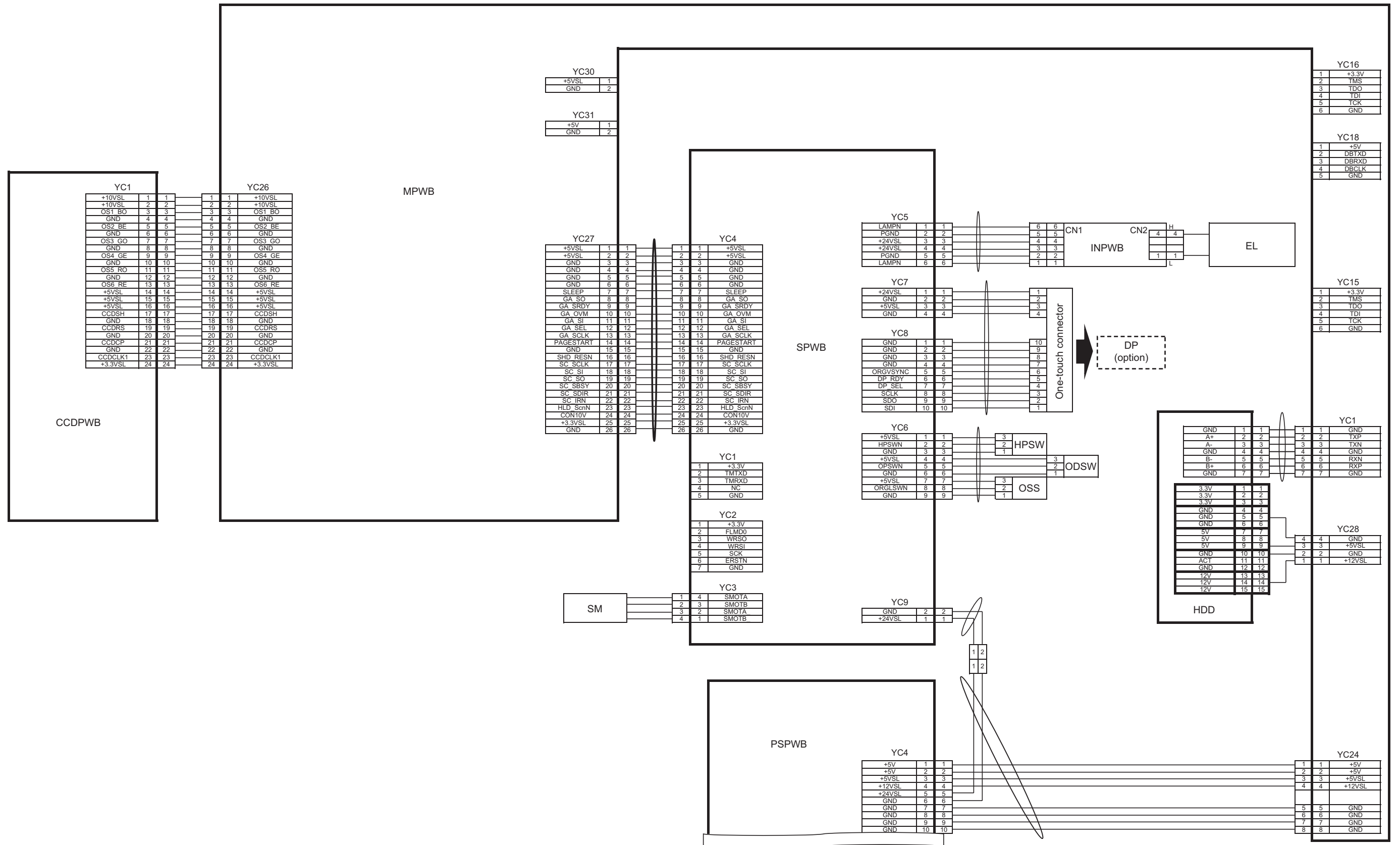

Wiring diagram No.5

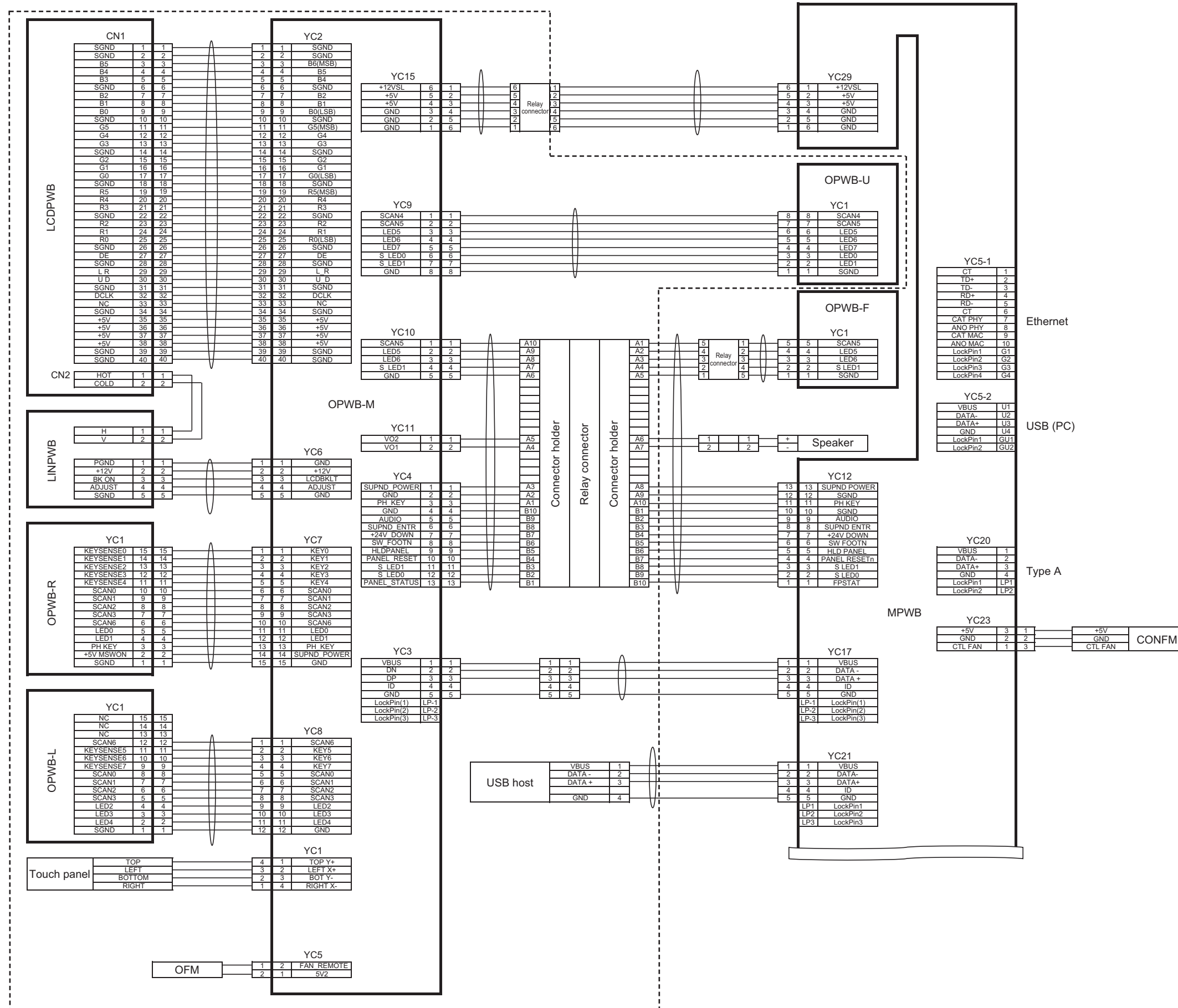

Wiring diagram No.6

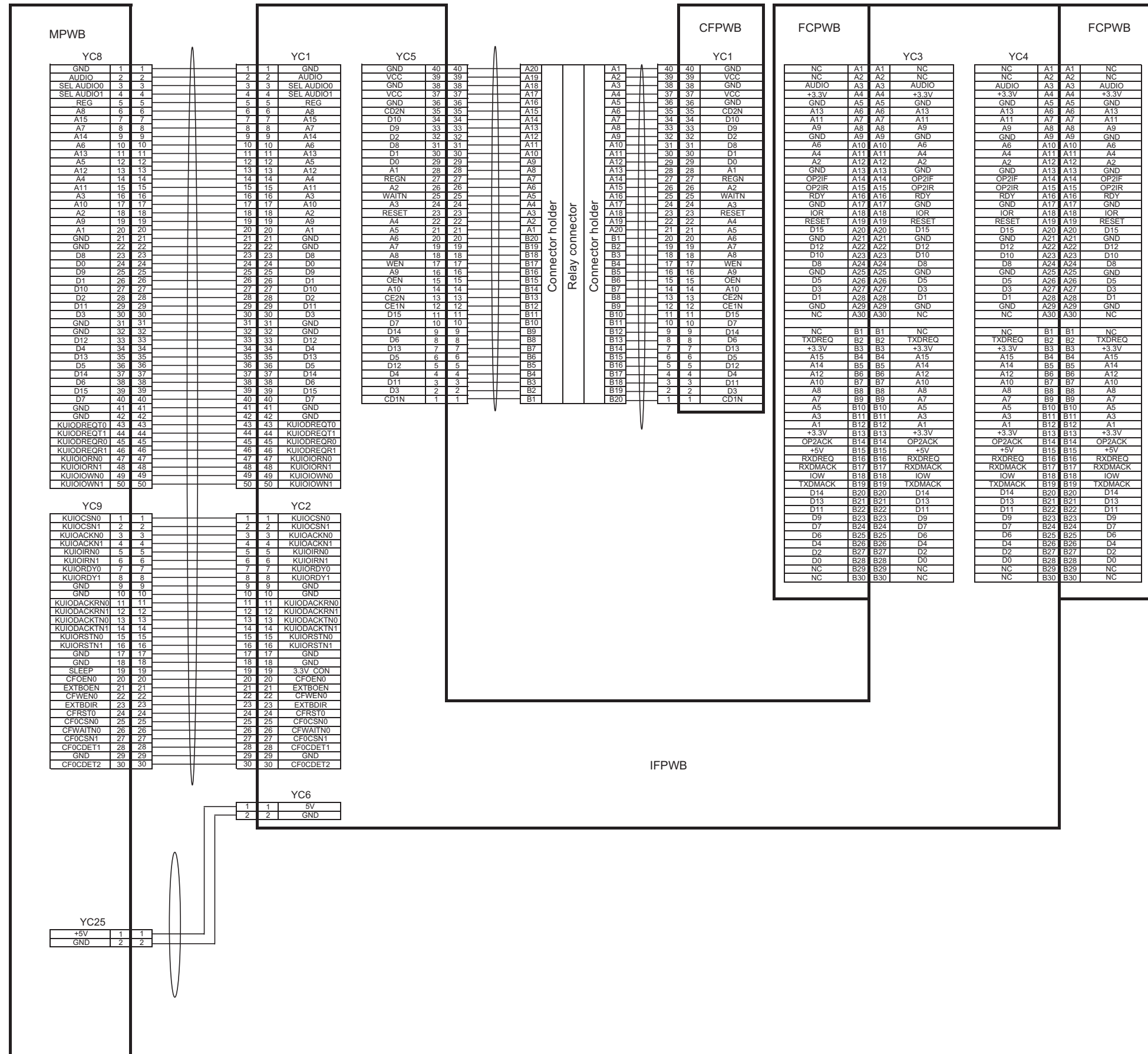

INSTALLATION GUIDE FOR DOCUMENT PROCESSOR

Output Connector for Interconnecting Cable is non-LPS.
Output: 357VA max.
Please use the item below Interconnecting Cable/
P/N: 303K546050

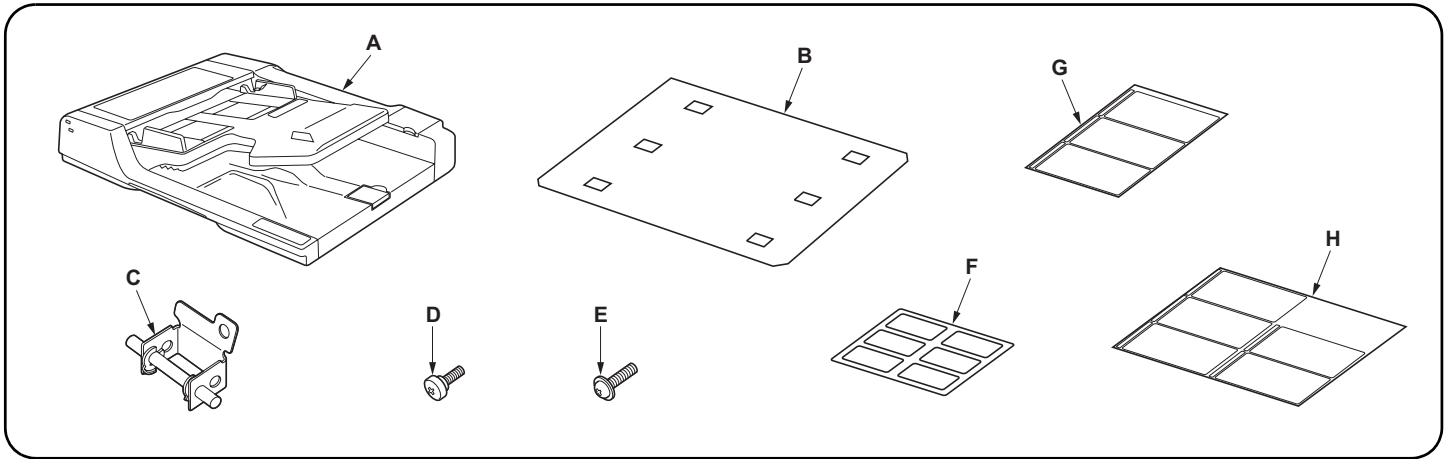

English

Supplied parts

A Document processor (DP)	1
B Original mat	1
C Angle adjusting plate	1
D Pin	2

E M4 × 14 screw	5
F Caution label [Face Up]	1
G Label A [Operation procedure]	1
H Label B [Operation procedure]	1

For the 110 V specification, label G is not bundled.

Français

Pièces fournies

A Chargeur de document (DP)	1
B Tapis d'original	1
C Plaque de réglage d'angle	1
D Goupille	2

E Vis M4 × 14	5
F Étiquette de précautions [Face vers le Haut]	1
G Étiquette A [Procédure d'utilisation]	1
H Étiquette B [Procédure d'utilisation]	1

Español

Piezas suministradas

A Procesador de documentos (DP)	1
B Plancha de originales	1
C Placa de ajuste de ángulo	1
D Pasador	2

E Tornillo M4 × 14	5
F Etiqueta de precaución [Cara Arriba]	1
G Etiqueta A [Procedimiento de funcionamiento]	1
H Etiqueta B [Procedimiento de funcionamiento]	1

Deutsch

Gelieferte Teile

A Vorlageneinzug (DP)	1
B Originalmatte	1
C Winkeleinstellhalter	1
D Rändelschraube	2

E M4 × 14 Schraube	5
F Warnaufkleber [Vorderseite Oben]	1
G Aufkleber A [Bedienungsverfahren]	1
H Aufkleber B [Bedienungsverfahren]	1

Italiano

Parti di fornitura

A Alimentatore di originali (DP)	1
B Coprioriginale	1
C Piastra di regolazione dell'angolo	1
D Perno	2

E Vite M4 × 14	5
F Etichetta di avvertenza [Faccia Insù]	1
G Etichetta A [Procedura di funzionamento]	1
H Etichetta B [Procedura di funzionamento]	1

简体中文

附属品

A 送稿器 (DP)	1
B 原稿垫	1
C 调整板	1
D 卡销	2

E 螺丝 M4 × 14	5
--------------------	---

(F)、(G) 和 (H) 并非附属品。

日本語

同梱品

A 原稿送り装置 (DP)	1
B 原稿マット	1
C 調整板	1
D ピン	2

E ビス M4 × 14	5
--------------------	---

(F)、(G)、(H) は、同梱されません。

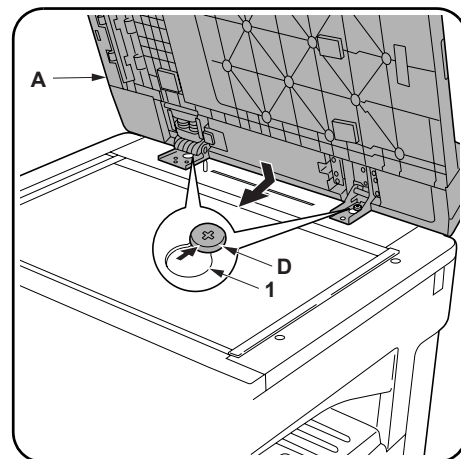
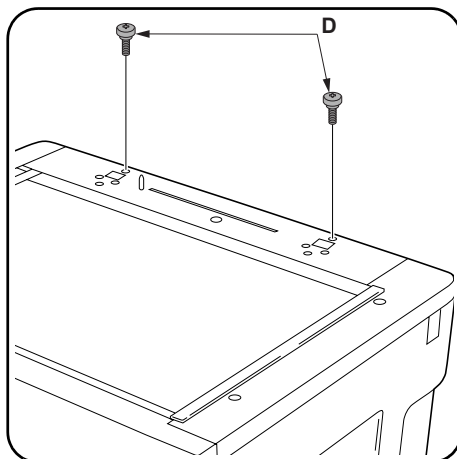

Precautions

- Be sure to remove any tape and/or cushioning material from supplied parts.
- Before installing the document processor, be sure to turn the main power switch of the machine off and unplug the power cable from the wall outlet.

Procedure Installing the DP

1. Install two pins (D).

2. Insert the pins (D) into the hinge holes (1) of DP (A) and slide the DP (A) toward the front side to install it.

Précautions

- Veillez à retirer les morceaux de bande adhésive et/ou les matériaux de rembourrage des pièces fournies.
- Avant d'installer le chargeur de document, veillez à mettre la machine hors tension et à débrancher le câble d'alimentation de la prise murale.

Procédure Installation du DP

1. Installez deux goupilles (D).

2. Insérez les goupilles (D) dans les orifices de charnière (1) du DP (A), puis faites glisser le DP (A) vers l'avant pour l'installer.

Precauciones

- Asegúrese de despegar todas las cintas y/o material amortiguador de las partes suministradas.
- Antes de instalar el procesador de documentos, asegúrese de desconectar el interruptor principal de la máquina y desenchufar el cable eléctrico del tomacorriente de la pared.

Procedimiento Instalación del DP

1. Instale dos pasadores (D).

2. Inserte los pasadores (D) en los orificios de bisagra (1) del DP (A) y deslice el DP (A) hacia el lado frontal para instalar.

Vorsichtsmaßnahmen

- Entfernen Sie Klebeband und/oder Dämpfungsmaterial vollständig von den mitgelieferten Teilen.
- Schalten Sie unbedingt den Betriebsschalter der Maschine aus, und trennen Sie das Netzkabel von der Netzsteckdose, bevor Sie den Vorlageneinzug installieren.

Verfahren Installieren des DP

1. Zwei Rändelschrauben (D) eindrehen.

2. Die Rändelschrauben (D) in die Scharnierlöcher (1) des DP (A) einführen, und den DP (A) zum Installieren nach vorn schieben.

Precauzioni

- Accertarsi di rimuovere tutti i nastri adesivi e/ o il materiale di imbottitura dalle parti fornite.
- Prima di installare l'alimentatore di originali, assicurarsi di spegnere l'interruttore principale di alimentazione della macchina e scollegare la spina del cavo di alimentazione dalla presa a muro della rete elettrica.

Procedura Installazione del DP

1. Inserire due perni (D).

2. Inserire i perni (D) nei fori della cerniera (1) del DP (A) e fare scorrere il DP (A) verso il lato anteriore per installarlo.

注意事項

- 如果附属品上带有固定胶带，缓冲材料时必须揭下。
- 安装 DP 时，必须先关闭机器主机的主电源开关，并拔下电源插头后，再进行安装作业。

安装步骤

安装 DP

1. 装上 2 个卡销 (D)。

2. 将卡销 (D) 插入 DP (A) 的铰链部孔 (1)，向跟前滑动装上 DP。

注意事項

- 同梱品に固定テープ、緩衝材が付いている場合は必ず取り外すこと。
- DP を設置する場合は、機械本体の主電源スイッチを OFF にし、電源プラグを抜いてから作業をおこなう。

設置手順

DP の取り付け

1. ビン (D) 2 本を取り付ける。

2. DP (A) のヒンジ部の穴 (1) にピン (D) を挿入し、手前にスライドして DP を取り付ける。

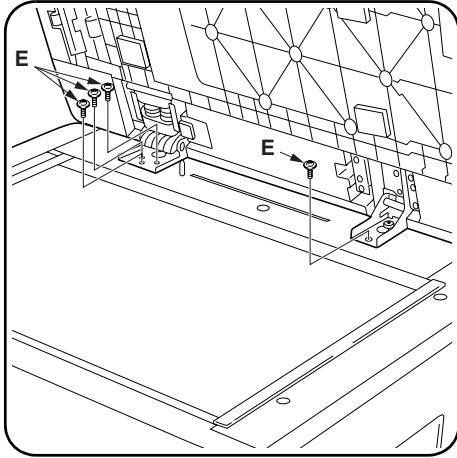

3. Fix the DP using four M4 × 14 screws (E).
Right: One
Left: Three

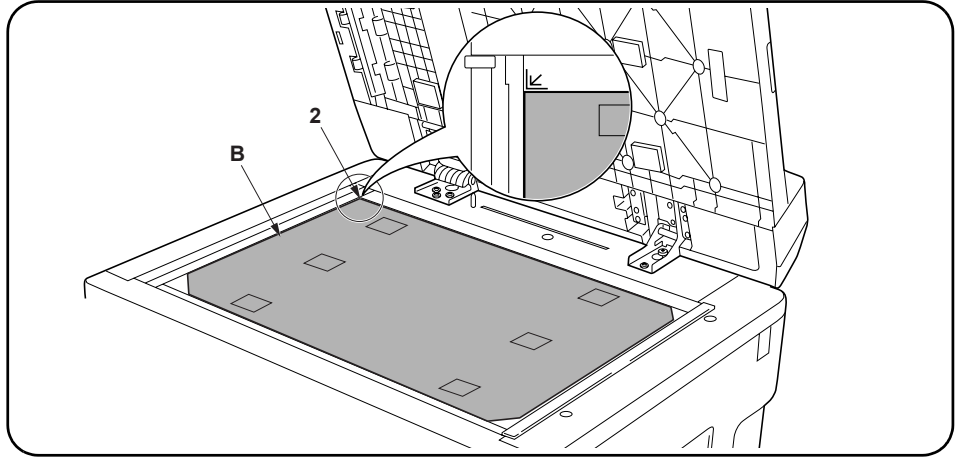

Attaching the original mat

4. Place the original mat (B) with its hook and loop fasteners up over the platen.
Align original mat (B) corner that has 90 degrees of angle with the inner left corner(2) of the original instruction panel.
5. Close the DP slowly to attach the original mat (B) onto it with the hook and loop fasteners.

3. Fixez le DP à l'aide de quatre vis M4 × 14 (E).
Côté droit: Une
Côté gauche: Trois

Fixation du tapis d'original

4. Placez le tapis d'original (B) sur la glace d'exposition avec son crochet et ses attaches à boucle orientées vers le haut.
Aligner le coin du plateau d'original (B) faisant un angle de 90 degrés avec le coin gauche(2) interne du panneau d'instructions d'original.
5. Refermez progressivement le DP pour fixer le tapis d'original (B) sur celui-ci avec le crochet et les attaches à boucle.

3. Fije el DP utilizando cuatro tornillos M4 × 14 (E).
Derecho: Uno
Izquierdo: Tres

Colocación de la plancha de originales

4. Coloque la plancha de originales (B) en su gancho y fijadores de bucle sobre el crystal de exposición.
Alinee la esquina que tiene un ángulo de 90 grados de la alfombrilla para originales (B) con la esquina interior izquierda(2) del panel de instrucciones para el original.
5. Cierre lentamente el DP para colocar la plancha de originales (B) con el gancho y fijadores de bucle.

3. Den DP mit vier M4 × 14 Schrauben (E) befestigen.
Rechts: Eine
Links: Drei

Anbringen der Originalmatte

4. Die Originalmatte (B) mit den Klettverschlüssen nach oben auf das Vorlagenglas legen.
Die Ecke der Originalmatte (B), die einen 90-Grad-Winkel aufweist, mit der linken(2), inneren Kante des Originalbedienfeldes ausrichten.
5. Den DP langsam schließen, so dass die Originalmatte (B) mit den Klettverschlüssen an ihm haftet.

3. Fissare il DP utilizzando quattro viti M4 × 14 (E).
Destra: Una
Sinistra: Tre

Montaggio del coprioriginale

4. Collocare il coprioriginale (B) sulla lastra di esposizione con il lato provvisto di nastro velcro autoadesivo rivolto verso l'alto.
Allineare l'angolo di 90 gradi del coprioriginale (B) con l'angolo interno sinistro(2) del pannello di controllo originale.
5. Chiudere lentamente il DP in modo che il coprioriginale (B) vi si possa fissare mediante il nastro velcro.

3. 用4个螺丝M4×14(E)固定DP。
右侧:1个
左侧:3个

安装原稿垫

4. 将原稿垫(B)上带有魔术贴的一面朝上,放置在稿台玻璃上。
将原稿垫(B)的90度角对准原稿指示板的内侧左角(2)。
5. 轻轻地放下DP,使原稿垫(B)粘在DP背面上。

3. ビスM4×14(E)4本でDPを固定する。
右側:1本
左側:3本

原稿マットの取り付け

4. 原稿マット(B)をマジックテープが付いている面を上にして、原稿ガラス上に置く。
原稿マット(B)は、90°になっている角を原稿指示板の左奥(2)に合わせる。
5. DP本体(A)をゆっくりと下ろし、原稿マット(B)をDP裏面に貼り付ける。

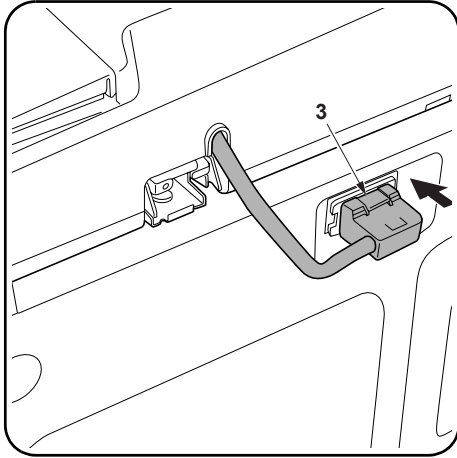

Connecting the signal cable

6. Connect the connector (3) of the signal cable to the machine.

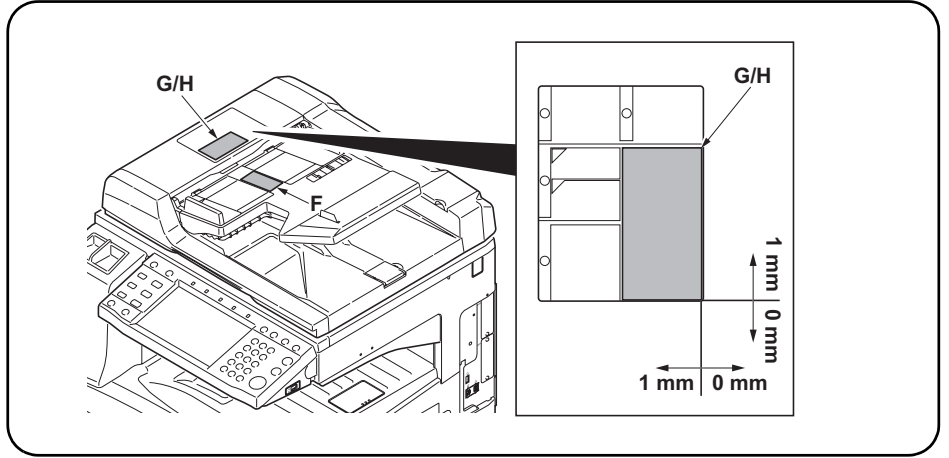

Adhering the labels

7. After cleaning with alcohol, adhere caution label [Face Up] (F), and label A [Operation procedure] (G) or label B (H) of the corresponding language, within the reference value range.

Connexion du câble de signal

6. Branchez le connecteur (3) du câble de signal sur la machine.

Apposition des étiquettes

7. Après avoir nettoyé la surface à l'alcool, apposez l'étiquette de précautions [Face vers le Haut] (F), et l'étiquette A [Procédure d'utilisation] (G) ou l'étiquette B (H) dans la langue voulue dans les limites de la plage des valeurs de référence.

Conexión del cable de señal

6. Conecte el conector (3) del cable de señal en la máquina.

Pegado de etiquetas

7. Después de limpiar con alcohol, pegue la etiqueta de precaución [Cara Arriba] (F) y la etiqueta A [Procedimiento de funcionamiento] (G), o la etiqueta B (H) del correspondiente idioma, dentro del rango del valor de referencia.

Anschließen des Signalkabels

6. Den Stecker (3) des Signalkabels an die Maschine anschließen.

Anbringen der Aufkleber

7. Nach der Reinigung der Klebeflächen mit Alkohol den Warnaufkleber [Vorderseite Oben] (F), den Aufkleber A [Bedienungsverfahren] (G) oder den Aufkleber B (H) der entsprechenden Sprache im Bezugswertebereich anbringen.

Collegamento del cavo del segnale

6. Collegare il connettore (3) del cavo del segnale alla macchina.

Applicazione delle etichette

7. Dopo aver pulito con alcol, applicare l'etichetta di avvertenza [Faccia Insù] (F), e l'etichetta A [Procedure di funzionamento] (G) o l'etichetta B (H) redatte nella lingua corrispondente, all'interno del campo del valore di riferimento.

连接信号线

6. 连接信号线的插头 (3)。

粘贴标签

7. 无需进行该项作业。

信号線の接続

6. 信号線のコネクタ (3) を接続する。

ラベルの貼り付け

7. この作業は、不要です。

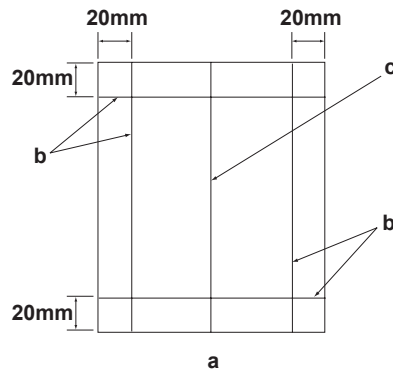

Checking the operation

1. To check the machine operation, prepare an A3 size original (a) where four lines (b) are drawn 20 mm from the edges and one line (c) is drawn at the center.
2. Connect the power plug to the wall outlet and turn the main power switch on.
3. Set the original (a) in the DP and make a proof copy to check the operation and the copy example.
4. If the gap between the original (a) and the copy example exceeds the reference value, perform adjustments. For the procedure, see the following pages.
Before checking image from the DP, check and adjust image from the machine. For details, see the service manual of the machine.

Vérification du fonctionnement

1. Pour vérifier le fonctionnement de la machine, préparez un original de format A3 (a) sur lequel quatre lignes (b) ont été tracées à 20 mm des bords, et sur lequel une ligne (c) a été tracée au centre.
2. Insérer la fiche d'alimentation de la machine dans la prise murale et mettre la machine sous tension.
3. Placez l'original (a) dans le DP et effectuez une copie de test pour vérifier le fonctionnement et l'exemple de copie.
4. Si l'écart entre l'original (a) et l'exemple de copie est supérieur à la valeur de référence, effectuez les réglages nécessaires. Pour la marche à suivre, reportez-vous aux pages suivantes.
Avant de vérifier l'image sur le DP, vérifier et régler l'image sur la machine. Pour plus de détails, se reporter au manuel de service de la machine.

Verificación del funcionamiento

1. Para verificar el funcionamiento de la máquina, prepare un original de tamaño A3 (a) donde se dibujan cuatro líneas (b) a 20 mm de los bordes y una línea (c) dibujada en el centro.
2. Conecte el enchufe eléctrico de la máquina en un tomacorriente de la pared y conecte el interruptor principal.
3. Coloque el original (a) en el DP y haga una copia de prueba para verificar el funcionamiento y una copia de muestra.
4. Si la separación entre el original (a) y la copia de muestra supera el valor de referencia, haga los ajustes. Para el procedimiento, vea las siguientes páginas.
Antes de verificar la imagen del DP, verifique y ajuste la imagen desde la máquina. Para detalles, vea el manual de servicio de la máquina.

Überprüfen des Betriebs

1. Um den Betrieb der Maschine zu prüfen, ein A3-Original (a) vorbereiten, das vier Linien (b) im Abstand von 20 mm von den Kanten und eine Linie (c) in der Mitte aufweist.
2. Den Netzstecker der Maschine in die Steckdose stecken und den Betriebsschalter einschalten.
3. Das Original (a) in den DP einlegen und eine Probekopie anfertigen, um den Betrieb und das Kopienmuster zu prüfen.
4. Falls die Abweichung zwischen dem Original (a) und dem Kopienmuster den Bezugswert überschreitet, müssen Einstellungen durchgeführt werden. Das Verfahren ist auf den folgenden Seiten beschrieben.
Bevor das Bild vom DP geprüft wird, ist das Bild von der Maschine zu prüfen und einzustellen. Einzelheiten sind der Wartungsanleitung der Maschine zu entnehmen.

Controllo del funzionamento

1. Per controllare il funzionamento della macchina, preparare un originale di formato A3 (a) dove sono state tracciate quattro linee (b) a 20 mm dai bordi e una linea (c) centrale.
2. Collegare la spina del cavo di alimentazione della macchina alla presa a muro della rete elettrica e accendere l'interruttore principale di alimentazione.
3. Collocare l'originale (a) nel DP e fare una copia di prova per controllare il funzionamento della macchina e l'esempio di copia.
4. Se la differenza tra l'originale (a) e la copia di prova supera il valore di riferimento, eseguire le regolazioni. Per la procedura, leggere le seguenti pagine.
Prima di controllare l'immagine dal DP, controllare e regolare l'immagine dalla macchina. Per ulteriori dettagli, leggere il manuale d'istruzioni della macchina.

動作確認

1. 准备好 A3 尺寸的纸张（在边起 20mm 处划有 4 条线 (b)）和动作确认用原稿 (a)（在纸张中心划有 1 条线 (c)）。
2. 将机器主机上的电源插头插入插座中，打开主电源开关。
3. 将原稿 (a) 放在 DP 上，进行测试复印。
确认操作和复印样本的状态。
4. 如果原稿 (a) 和复印样本的偏移超过标准值时，需要调整。（调整方法参照下页以后）
确认和调整机器主机的图像后，必须对 DP 图像进行确认。详情请参照机器主机的维修手册。

動作確認

1. A3 サイズの用紙の端から 20mm の位置に線 (b) 4 本と、用紙の中心に線 (c) 1 本を引いた動作確認用の原稿 (a) を用意する。
2. 機械本体の電源プラグをコンセントに差し込み、主電源スイッチを ON にする。
3. 原稿 (a) を DP にセットし、テストコピーをおこなう。
動作およびコピーサンプルを確認する。
4. 原稿 (a) とコピーサンプルに基準値以上のずれがある場合は調整をおこなう。（調整方法は、次ページ以降を参照）
機械本体の画像確認および調整をおこなってから、DP の画像確認をおこなうこと。詳細は機械本体のサービスマニュアル参照。

Checking image from the DP

Be sure to adjust in the following order. If not, the adjustment cannot be performed correctly.

For checking the angle of leading edge, see page 7.	<Reference value>	Simplex copying: within ± 3.0 mm; Duplex copying: within ± 4.0 mm
For checking the angle of trailing edge, see page 10.	<Reference value>	Simplex copying: within ± 3.0 mm; Duplex copying: within ± 4.0 mm
For checking the magnification, see page 14.	<Reference value>	Within $\pm 1.5\%$
For checking the leading edge timing, see page 16.	<Reference value>	Within ± 2.0 mm
For checking the center line, see page 18.	<Reference value>	Simplex copying: within ± 2.0 mm; Duplex copying: within ± 3.0 mm

When using the original for adjustment, automatic adjustment of magnification, leading edge timing and center line can be performed at a time.
For the automatic adjustment using the original for adjustment, see page 20.

Vérification de l'image sur le DP

Veillez à effectuer le réglage en procédant dans l'ordre suivant. Sinon, il sera impossible d'obtenir un réglage correct.

Pour vérifier l'angle du bord avant, reportez-vous à la page 7.	<Valeur de référence>	Copie recto seul: $\pm 3,0$ mm max.; copie recto verso: $\pm 4,0$ mm max.
Pour vérifier l'angle du bord arrière, reportez-vous à la page 10.	<Valeur de référence>	Copie recto seul: $\pm 3,0$ mm max.; copie recto verso: $\pm 4,0$ mm max.
Pour vérifier l'agrandissement, reportez-vous à la page 14.	<Valeur de référence>	$\pm 1,5\%$ max.
Pour vérifier la synchronisation du bord avant, reportez-vous à la page 16.	<Valeur de référence>	$\pm 2,0$ mm max.
Pour vérifier la ligne médiane, reportez-vous à la page 18.	<Valeur de référence>	Copie recto seul: $\pm 2,0$ mm max.; copie recto verso: $\pm 3,0$ mm max.

Lorsque vous utilisez l'original pour effectuer le réglage, vous pouvez effectuer automatiquement le réglage de l'agrandissement, de la synchronisation du bord avant et de la ligne médiane en une seule fois.
Pour le réglage automatique en utilisant l'original pour effectuer le réglage, reportez-vous à la page 20.

Verificación de la imagen del DP

Asegúrese de ajustar en el siguiente orden. De lo contrario, el ajuste no puede hacerse correctamente.

Para verificar el ángulo del borde superior, vea la página 7.	<Valor de referencia>	Copia simple: dentro de $\pm 3,0$ mm; Copia duplex: dentro de $\pm 4,0$ mm
Para verificar el ángulo del borde inferior, vea la página 10.	<Valor de referencia>	Copia simple: dentro de $\pm 3,0$ mm; Copia duplex: dentro de $\pm 4,0$ mm
Para verificar el cambio de tamaño, vea la página 14.	<Valor de referencia>	Dentro de $\pm 1,5\%$
Para verificar la sincronización del borde inferior, vea la página 16.	<Valor de referencia>	Dentro de $\pm 2,0$ mm
Para verificar la línea central, vea la página 18.	<Valor de referencia>	Copia simple: dentro de $\pm 2,0$ mm; Copia duplex: dentro de $\pm 3,0$ mm

Cuando utilice el original para el ajuste, puede hacerse un ajuste automático del cambio de tamaño, sincronización del borde superior y línea central al mismo tiempo. Para el ajuste automático utilizando el original para el ajuste, vea la página 20.

Überprüfen des Bilds vom DP

Die Einstellung in der folgenden Reihenfolge durchführen. Anderenfalls kann die Einstellung nicht korrekt durchgeführt werden.

Angaben zur Prüfung des Winkels der Vorderkante auf Seite 7.	<Bezugswert>	Simplexkopie: innerhalb $\pm 3,0$ mm; Duplexkopie: innerhalb $\pm 4,0$ mm
Angaben zur Prüfung des Winkels der Hinterkante auf Seite 10.	<Bezugswert>	Simplexkopie: innerhalb $\pm 3,0$ mm; Duplexkopie: innerhalb $\pm 4,0$ mm
Angaben zur Prüfung der Vergrößerung auf Seite 14.	<Bezugswert>	Innerhalb $\pm 1,5\%$
Angaben zur Prüfung des Vorderkanten-Timings auf Seite 16.	<Bezugswert>	Innerhalb $\pm 2,0$ mm
Angaben zur Prüfung der Mittellinie auf Seite 18.	<Bezugswert>	Simplexkopie: innerhalb $\pm 2,0$ mm; Duplexkopie: innerhalb $\pm 3,0$ mm

Bei Verwendung des Originals für die Einstellung können die automatischen Einstellungen für Vergrößerung, Vorderkanten-Timing und Mittellinie gleichzeitig durchgeführt werden.
Angaben zur automatischen Einstellung mithilfe des Originals auf Seite 20.

Controllo di immagine dal DP

Verificare che la regolazione avvenga nel seguente ordine. Altrimenti, la regolazione non potrà essere seguita correttamente.

Per controllare l'angolo del bordo principale, vedere pagina 7.	<Valore di riferimento>	Copia simplex: entro $\pm 3,0$ mm; Copia duplex: entro $\pm 4,0$ mm
Per controllare l'angolo del bordo di uscita, vedere pagina 10.	<Valore di riferimento>	Copia simplex: entro $\pm 3,0$ mm; Copia duplex: entro $\pm 4,0$ mm
Per controllare l'ingrandimento, vedere pagina 14.	<Valore di riferimento>	Entro $\pm 1,5\%$
Per controllare la sincronizzazione del bordo principale, vedere pagina 16.	<Valore di riferimento>	Entro $\pm 2,0$ mm
Per controllare la linea centrale, vedere pagina 18.	<Valore di riferimento>	Copia simplex: entro $\pm 2,0$ mm; Copia duplex: entro $\pm 3,0$ mm

Quando si utilizza l'originale per la regolazione, la regolazione automatica dell'ingrandimento, della sincronizzazione del bordo principale e della linea centrale possono essere eseguiti contemporaneamente.
Per la regolazione automatica eseguita con l'originale, vedere pagina 20.

<< 图像确认 >>

必须按照以下步骤进行调整, 否则不能达到准确调整的要求。

• 确认前端倾斜度 第 7 页	<标准值>	单面: ± 3.0 mm 以内、双面: ± 4.0 mm 以内
• 确认后端倾斜度 第 10 页	<标准值>	单面: ± 3.0 mm 以内、双面: ± 4.0 mm 以内
• 确认等倍度 第 14 页	<标准值>	$\pm 1.5\%$ 以内
• 确认前端定时调整 第 16 页	<标准值>	± 2.0 mm 以内
• 确认中心线 第 18 页	<标准值>	单面: ± 2.0 mm 以内、双面: ± 3.0 mm 以内

使用调整用原稿功能时, 可以同时自动进行等倍度、前端定时以及中心线的调整。
• 通过调整用原稿进行自动调整 第 20 页

<< 画像の確認 >>

必ず下記の順序で調整を行うこと。順序通りに調整を行わない場合、正しい調整ができない。

• 先端斜め確認 7 ページ	<基準値>	片面: ± 3.0 mm 以内、両面: ± 4.0 mm 以内
• 後端斜め確認 10 ページ	<基準値>	片面: ± 3.0 mm 以内、両面: ± 4.0 mm 以内
• 等倍度確認 14 ページ	<基準値>	$\pm 1.5\%$ 以内
• 先端タイミング確認 16 ページ	<基準値>	± 2.0 mm 以内
• センターライン確認 18 ページ	<基準値>	片面: ± 2.0 mm 以内、両面: ± 3.0 mm 以内

調整用原稿を使用すると、等倍度調整、先端タイミング調整、センターライン調整の自動調整が一度におこなえる。

• 調整用原稿による自動調整 20 ページ

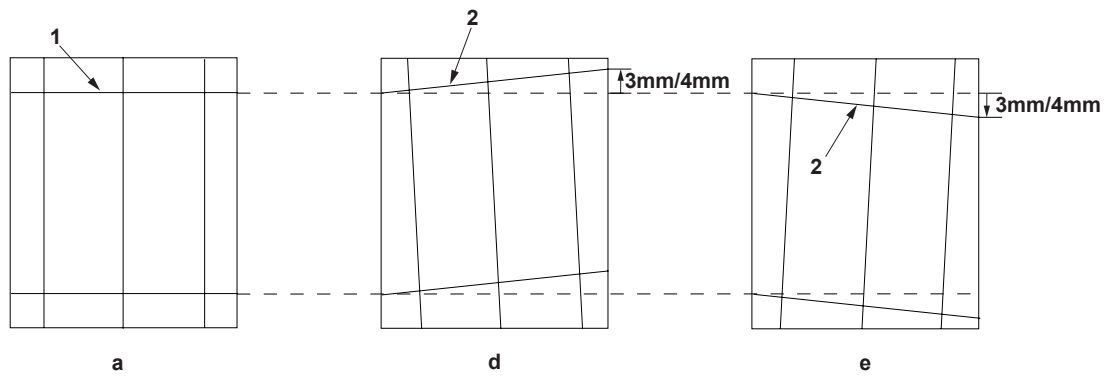

Checking the angle of leading edge

Check the gap between line (1) of original (a) and line (2) of copy example. If the gap exceeds the reference value, perform the following adjustment.

<Reference value>

For simplex copying: Within ± 3.0 mm

For duplex copying: Within ± 4.0 mm

Vérification de l'angle du bord avant

Vérifiez l'écart entre la ligne (1) de l'original (a) et la ligne (2) de l'exemple de copie. Si l'écart est supérieur à la valeur de référence, effectuez le réglage suivant.

<Valeur de référence>

Copie recto seul: $\pm 3,0$ mm max.

Copie recto verso: $\pm 4,0$ mm max.

Verificación del ángulo del borde superior

Verifique la separación entre la línea (1) del original (a) y la línea (2) de la copia de muestra. Si la superación supera el valor de referencia, haga el siguiente ajuste.

<Valor de referencia>

Para copia simple: Dentro de $\pm 3,0$ mm

Para copia duplex: Dentro de $\pm 4,0$ mm

Überprüfen des Winkels der Vorderkante

Die Abweichung der Linie (1) des Originals (a) und der Linie (2) des Kopienmusters prüfen. Überschreitet die Abweichung den Bezugswert, ist die folgende Einstellung durchzuführen.

<Bezugswert>

Für Simplexkopie: Innerhalb $\pm 3,0$ mm

Für Duplexkopie: Innerhalb $\pm 4,0$ mm

Controllo dell'angolo del bordo principale

Controllare la differenza tra la linea (1) dell'originale (a) e la linea (2) della copia di esempio. Se la differenza supera il valore di riferimento, effettuare la seguente regolazione.

<Valore di riferimento>

Per copia simplex: Entro $\pm 3,0$ mm

Per copia duplex: Entro $\pm 4,0$ mm

確認前端傾斜度

確認原稿 (a) の線 (1) と复印样本線 (2) のずれを確認する。如果超过标准值时, 必须进行調整。

<标准值>

单面时: ± 3.0 mm 以内

双面时: ± 4.0 mm 以内

先端斜め確認

原稿 (a) の線 (1) とコピーサンプルの線 (2) のずれを確認する。ずれが基準値外の場合は調整をおこなう。

<基準値>

片面の場合: ± 3.0 mm 以内

両面の場合: ± 4.0 mm 以内

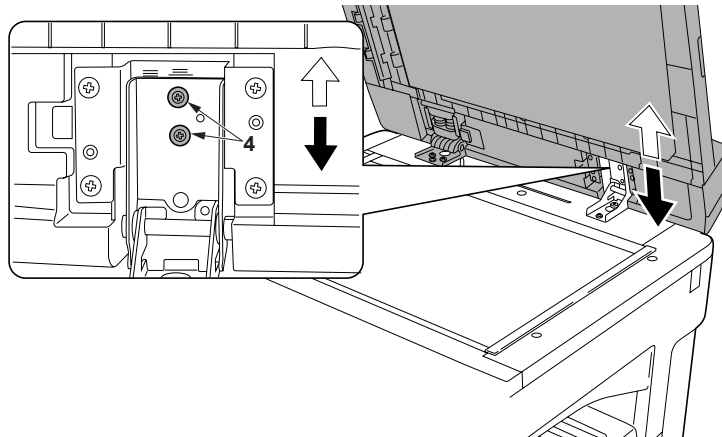

Adjusting the DP

1. Open the DP and loosen two adjusting screws (4) of right hinge.
2. Adjust the position of the DP.
For copy example (d): Move the DP down (⇐).
For copy example (e): Move the DP up (⇒).
Amount of change per scale: Approx. 0.5 mm

3. Tighten two adjusting screws (4).

4. Remove the original mat (B) and refit it (see steps 4 and 5 on page 3).

Réglage du DP

1. Ouvrez le DP et desserrez les deux vis de réglage (4) de la charnière droite.
2. Réglez la position du DP.
Pour l'exemple de copie (d): Déplacez le DP vers le bas (⇐).
Pour l'exemple de copie (e): Déplacez le DP vers le haut (⇒).
Quantité de changement par pas: Environ 0,5 mm

3. Resserrez les deux vis de réglage (4).

4. Retirez le tapis d'original (B) et remettez-le en place. (Reportez-vous aux étapes 4 et 5 à la page 3.)

Ajuste del DP

1. Abra el DP y afloje los dos tornillos de ajuste (4) de la bisagra derecha.
2. Ajuste la posición del DP.
Para la copia de muestra (d): Mueva el DP abajo (⇐).
Para la copia de muestra (e): Mueva el DP arriba (⇒).
Cantidad de cambio de escala: Aprox. 0,5 mm

3. Apriete los tornillos de ajuste (4).

4. Desmonte la plancha de original (B) y vuelva a colocar (vea los pasos 4 y 5 en la página 3).

Einstellen des DP

1. Den DP öffnen, und die zwei Einstellschrauben (4) des rechten Scharniers lösen.
2. Die Position des DP einstellen.
Für Kopienmuster (d): Den DP absenken (⇐).
Für Kopienmuster (e): Den DP anheben (⇒).
Änderungsbetrag pro Skalenstrich: Ca. 0,5 mm

3. Die zwei Einstellschrauben (4) wieder festziehen.

4. Die Originalmatte (B) abnehmen und wieder anbringen (siehe Schritte 4 und 5 auf Seite 3).

Regolazione del DP

1. Aprire il DP e allentare le due viti di regolazione (4) della cerniera destra.
2. Regolare la posizione del DP.
Per un esempio di copia (d): Muovere il DP verso il basso (⇐).
Per un esempio di copia (e): Muovere il DP verso l'alto (⇒).
Variazione graduale: Circa 0,5 mm

3. Stringere le due viti di regolazione (4).

4. Rimuovere il coprioriginale (B) e reinserirlo (vedere i passi 4 e 5 a pagina 3).

調整 DP

1. 打开 DP，拧松铰链右侧的 2 个调整螺丝 (4)。
2. 调整 DP 的位置。
复印样本 (d) 时：将 DP 向下 (⇐) 移动。
复印样本 (e) 时：将 DP 向上 (⇒) 移动。
每 1 格的移动量：约 0.5mm

3. 紧固 2 个调整螺丝 (4)。

4. 拆下原稿垫 (B)，参照第 3 页的步骤 4 和 5 再次装上。

DP の調整

1. DP を開き、ヒンジ右側の調整ビス (4) 2 本をゆるめる。
2. DP の位置を調整する。
コピーサンプル (d) の場合: DP 本体を下 (⇐) へ動かす。
コピーサンプル (e) の場合: DP 本体を上 (⇒) へ動かす。
1 目盛り当たりの変化量: 約 0.5mm

3. 調整ビス (4) 2 本を締める。

4. 原稿マット (B) を取り外し、3 ページの手順 4、5 を参考に再度取り付ける。

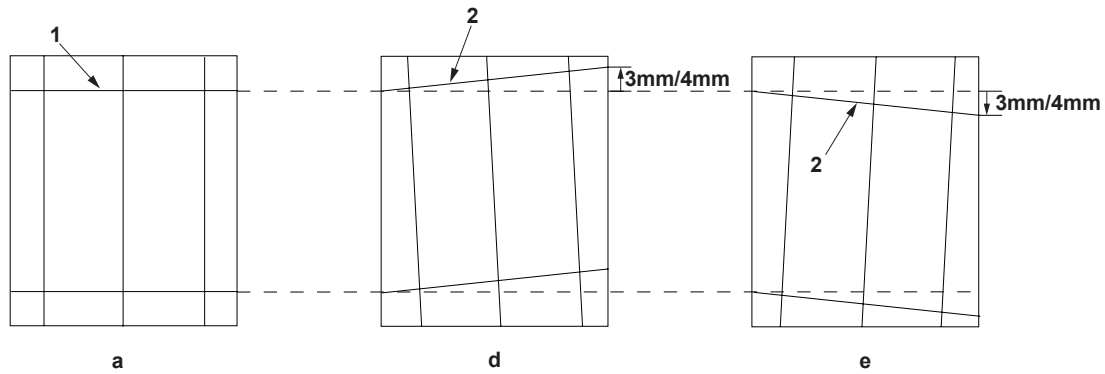

5. Make a proof copy again.
6. Repeat steps 1 to 5 until line (2) of copy example shows the following the reference values.
 <Reference value>
 For simplex copying: Within ± 3.0 mm
 For duplex copying: Within ± 4.0 mm

5. Effectuez à nouveau une copie de test.
6. Répétez les étapes 1 à 5 jusqu'à ce que la ligne (2) de l'exemple de copie corresponde aux valeurs de référence suivantes.
 <Valeur de référence>
 Copie recto seul: $\pm 3,0$ mm max.
 Copie recto verso: $\pm 4,0$ mm max.

5. Haga otra copia de prueba.
6. Repita los pasos 1 a 5 hasta que la línea (2) de la copia de muestra tenga los siguientes valores de referencia.
 <Valor de referencia>
 Para copia simple: Dentro de $\pm 3,0$ mm
 Para copia duplex: Dentro de $\pm 4,0$ mm

5. Eine erneute Probekopie anfertigen.
6. Die Schritte 1 bis 5 wiederholen, bis die Linie (2) des Kopienmusters die folgenden Bezugswerte aufweist.
 <Bezugswert>
 Für Simplexkopie: Innerhalb $\pm 3,0$ mm
 Für Duplexkopie: Innerhalb $\pm 4,0$ mm

5. Eseguire di nuovo una prova di copia.
6. Ripetere i passi da 1 a 5 fino a che la linea (2) dell'esempio di copia non mostra i seguenti valori di riferimento.
 <Valore di riferimento>
 Per copia simplex: Entro $\pm 3,0$ mm
 Per copia duplex: Entro $\pm 4,0$ mm

5. 再次进行测试复印。
6. 反复操作步骤 1 ~ 5, 直至复印样本的线 (2) 为标准值内。
 <标准值>
 单面时: ± 3.0 mm 以内
 双面时: ± 4.0 mm 以内

5. 再度テストコピーをおこなう。
6. コピーサンプルの線 (2) が基準値内になるまで、手順 1 ~ 5 を繰り返す。
 <基準値>
 片面の場合: ± 3.0 mm 以内
 両面の場合: ± 4.0 mm 以内

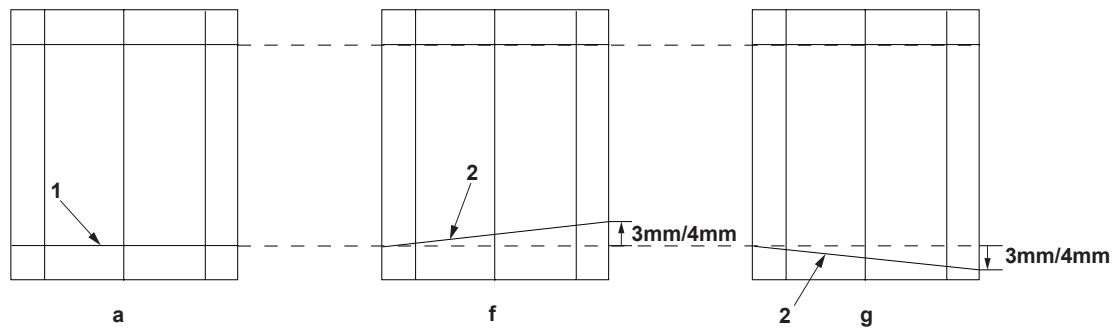

Checking the angle of trailing edge

Check the gap between line (1) of original (a) and line (2) of copy example. If the gap exceeds the reference value, perform the following adjustment.

<Reference value>

For simplex copying: Within ± 3.0 mm

For duplex copying: Within ± 4.0 mm

Vérification de l'angle du bord arrière

Vérifiez l'écart entre la ligne (1) de l'original (a) et la ligne (2) de l'exemple de copie. Si l'écart est supérieur à la valeur de référence, effectuez le réglage suivant.

<Valeur de référence>

Copie recto seul: $\pm 3,0$ mm max.

Copie recto verso: $\pm 4,0$ mm max.

Verificación del ángulo del borde inferior

Verifique la separación entre la línea (1) del original (a) y la línea (2) de la copia de muestra. Si la superación supera el valor de referencia, haga el siguiente ajuste.

<Valor de referencia>

Para copia simple: Dentro de $\pm 3,0$ mm

Para copia duplex: Dentro de $\pm 4,0$ mm

Überprüfen des Winkels der Hinterkante

Die Abweichung der Linie (1) des Originals (a) und der Linie (2) des Kopienmusters prüfen. Überschreitet die Abweichung den Bezugswert, ist die folgende Einstellung durchzuführen.

<Bezugswert>

Für Simplexkopie: Innerhalb $\pm 3,0$ mm

Für Duplexkopie: Innerhalb $\pm 4,0$ mm

Controllo dell'angolo del bordo di uscita

Controllare la differenza tra la linea (1) dell'originale (a) e la linea (2) della copia di esempio. Se la differenza supera il valore di riferimento, effettuare la seguente regolazione.

<Valore di riferimento>

Per copia simplex: Entro $\pm 3,0$ mm

Per copia duplex: Entro $\pm 4,0$ mm

确认后端倾斜度

确认原稿 (a) 线 (1) 和复印样本线 (2) 的偏移。如果超过标准值时, 必须进行调整。

<标准值>

单面时: ± 3.0 mm 以内

双面时: ± 4.0 mm 以内

後端斜め確認

原稿 (a) の線 (1) とコピーサンプルの線 (2) のずれを確認する。ずれが基準値外の場合は調整をおこなう。

<基準値>

片面の場合: ± 3.0 mm 以内

両面の場合: ± 4.0 mm 以内

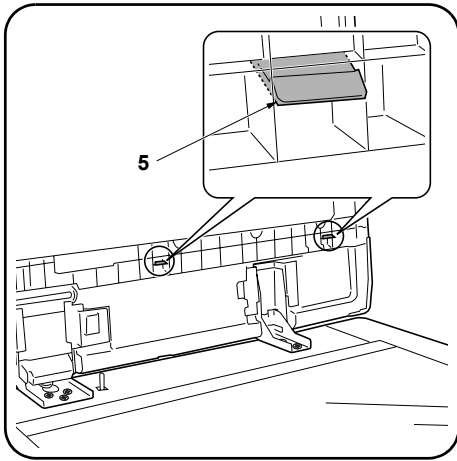

Adjusting the DP

1. Open the DP and release two latches (5) using a flat-head screwdriver.

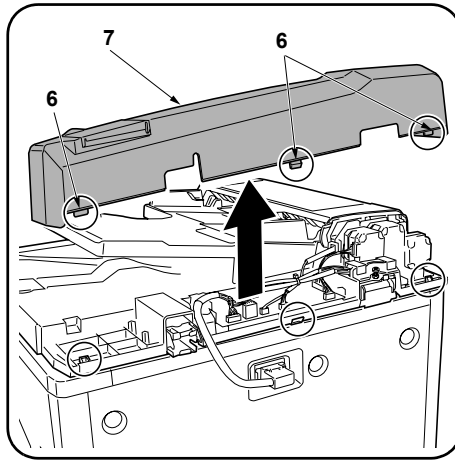

2. Release three latches (6) at the rear of the DP using a flat-head screwdriver to remove the cover (7).

Réglage du DP

1. Ouvrez le DP et libérez les deux verrous (5) à l'aide d'un tournevis à tête plate.

2. Libérez les trois verrous (6) situés à l'arrière du DP en utilisant un tournevis à tête plate pour retirer le capot (7).

Ajuste del DP

1. Abra el DP y suelte los dos pestillos (5) utilizando un destornillador de punta plana.

2. Suelte los tres pestillos (6) en el lado trasero del DP utilizando un destornillador de punta plana para desmontar la cubierta (7).

Einstellen des DP

1. Den DP öffnen, und die zwei Rasten (5) mit einem Flachschaubenzieher lösen.

2. Die drei Rasten (6) auf der Rückseite des DP mit einem Flachschaubenzieher lösen, um die Abdeckung (7) zu entfernen.

Regolazione del DP

1. Aprire il DP e rilasciare i due fermi (5) utilizzando un giravite a punta piatta.

2. Rilasciare i tre fermi (6) sul retro del DP utilizzando un giravite a punta piatta per rimuovere il coperchio (7).

調整 DP

1. 打开 DP, 用一字形螺丝刀等松开 2 处嵌入部 (5)。

2. 用一字形螺丝刀等松开 DP 后侧的 3 处嵌入部 (6), 并拆下盖板 (7)。

DP の調整

1. DP を開き、はめ込み (5) 2 箇所をマイナスドライバなどで解除する。

2. DP 後側のはめ込み (6) 3 箇所をマイナスドライバなどで解除し、カバー (7) を取り外す。

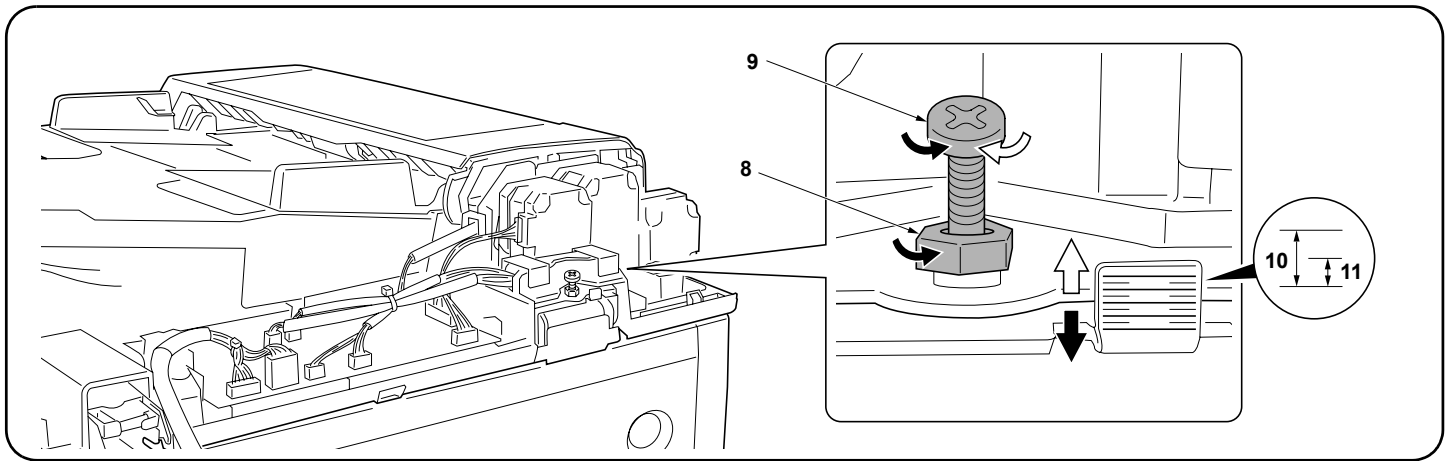

3. Adjust the height of DP.

Loosen the nut (8).

For copy example (f): Loosen the adjusting screw (9). (←)

For copy example (g): Tighten the adjusting screw (9). (→)

Amount of change per scale: Approx. 1 mm (10)/ Approx. 0.5 mm (11)

Retighten the nut (8).

4. Refit the cover (7) removed in step 2.

5. Remove the original mat (B) and refit it (see steps 4 and 5 on page 3).

3. Réglez la hauteur du DP.

Desserrez l'écrou (8).

Pour l'exemple de copie (f): Desserrez la vis de réglage (9). (←)

Pour l'exemple de copie (g): Serrez la vis de réglage (9). (→)

Quantité de changement par pas: environ 1 mm (10) / environ 0,5 mm (11)

Resserrez l'écrou (8).

4. Remettez en place le capot (7) retiré auparavant à l'étape 2.

5. Retirez le tapis d'original (B) et remettez-le en place. (Reportez-vous aux étapes 4 et 5 à la page 3.)

3. Ajuste la altura del DP.

Afloje la tuerca (8).

Para la copia de muestra (f): Afloje el tornillo de ajuste (9). (←)

Para la copia de muestra (g): Apriete el tornillo de ajuste (9). (→)

Cantidad de cambio de escala: Aprox. 1 mm (10)/aprox. 0,5 mm (11)

Vuelva a apretar la tuerca (8).

4. Vuelva a colocar la cubierta (7) desmontada en el paso 2.

5. Desmonte la plancha de original (B) y vuelva a colocar (vea los pasos 4 y 5 en la página 3).

3. Die Höhe des DP einstellen.

Lösen Sie die Mutter (8).

Für Kopienmuster (f): Lösen Sie die Einstellschraube (9). (←)

Für Kopienmuster (g): Die Einstellschraube (9) festziehen. (→)

Änderungsbetrag pro Skalenstrich: ca. 1 mm (10)/ca. 0,5 mm (11)

Ziehen Sie die Mutter (8) wieder fest.

4. Die in Schritt 2 entfernte Abdeckung (7) wieder anbringen.

5. Die Originalmatte (B) abnehmen und wieder anbringen (siehe Schritte 4 und 5 auf Seite 3).

3. Regolazione dell'altezza del DP

Allentare il dado (8).

Per un esempio di copia (f): Allentare la vite di regolazione (9). (←)

Per un esempio di copia (g): Stringere la vite di regolazione (9). (→)

Variazione graduale: circa 1 mm (10) / circa 0,5 mm (11)

Stringere di nuovo il dado (8).

4. Reinserrire il coperchio (7) rimosso nel passo 2.

5. Rimuovere il coprioriginale (B) e reinserirlo (vedere i passi 4 e 5 a pagina 3).

3. 調整 DP の高度。

拧松螺母 (8)。

复印样本 (f) 时: 拧松调整螺丝 (9)。(←)

复印样本 (g) 时: 紧固调整螺丝 (9)。(→)

每 1 格的移动量: 约 1mm(10) / 约 0.5mm(11)

将螺母 (8) 按原样紧固好。

4. 在步骤 2 拆下的盖板 (7) 按原样装好。

5. 拆下原稿垫 (B), 参照第 3 页的步骤 4 和 5 再次装上。

3. DP の高さを調整する。

ナット (8) をゆるめる。

コピーサンプル (f) の場合: 調整ビス (9) をゆるめる。(←)

コピーサンプル (g) の場合: 調整ビス (9) を締める。(→)

1 目盛り当たりの変化量: 約 1mm(10) / 約 0.5mm(11)

ナット (8) を元通り締める。

4. 手順 2 で取り外したカバー (7) を元通り取り付け。

5. 原稿マット (B) を取り外し、3 ページの手順 4、5 を参考に再度取り付け。

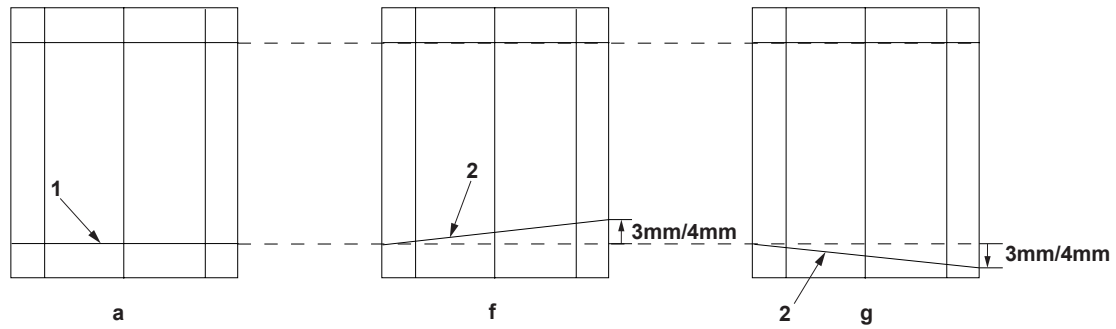

6. Make a proof copy again.
 7. Repeat steps 1 to 6 until line (2) of copy example shows the following the reference values.
 <Reference value>
 For simplex copying: Within ± 3.0 mm
 For duplex copying: Within ± 4.0 mm

6. Effectuez à nouveau une copie de test.
 7. Répétez les étapes 1 à 6 jusqu'à ce que la ligne (2) de l'exemple de copie corresponde aux valeurs de référence suivantes.
 <Valeur de référence>
 Copie recto seul: $\pm 3,0$ mm max.
 Copie recto verso: $\pm 4,0$ mm max.

6. Haga otra copia de prueba.
 7. Repita los pasos 1 a 6 hasta que la línea (2) de la copia de muestra tenga los siguientes valores de referencia.
 <Valor de referencia>
 Para copia simple: Dentro de $\pm 3,0$ mm
 Para copia duplex: Dentro de $\pm 4,0$ mm

6. Eine erneute Probekopie anfertigen.
 7. Die Schritte 1 bis 6 wiederholen, bis die Linie (2) des Kopienmusters die folgenden Bezugswerte aufweist.
 <Bezugswert>
 Für Simplexkopie: Innerhalb $\pm 3,0$ mm
 Für Duplexkopie: Innerhalb $\pm 4,0$ mm

6. Eseguire di nuovo una prova di copia.
 7. Ripetere i passi da 1 a 6 fino a che la linea (2) dell'esempio di copia non mostra i seguenti valori di riferimento.
 <Valore di riferimento>
 Per copia simplex: Entro $\pm 3,0$ mm
 Per copia duplex: Entro $\pm 4,0$ mm

6. 再次进行测试复印。
 7. 反复操作步骤 1 ~ 6, 直至复印样本的线 (2) 为标准值内。
 <标准值>
 单面时: ± 3.0 mm 以内
 双面时: ± 4.0 mm 以内

1. 再度テストコピーをおこなう。
 2. コピーサンプルの線 (2) が基準値内になるまで、手順 1 ~ 6 を繰り返す。
 <基準値>
 片面の場合: ± 3.0 mm 以内
 両面の場合: ± 4.0 mm 以内

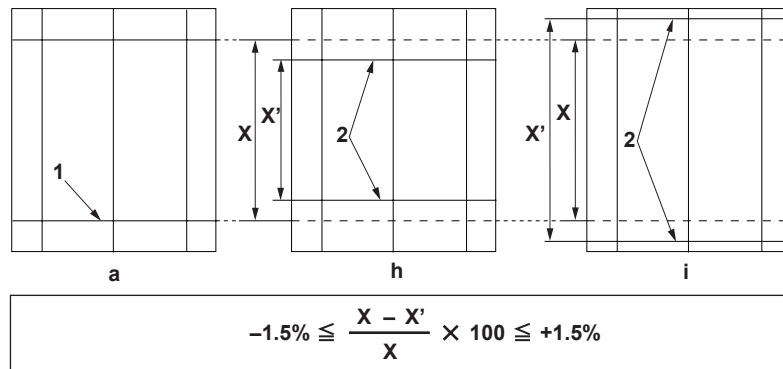

Checking the magnification

Check the gap between line (1) of original (a) and line (2) of copy example. If the gap exceeds the reference value, perform the following adjustment.

Reference value: Within $\pm 1.5\%$

Adjusting the DP magnification

1. Enter the maintenance mode and run the maintenance item U070 to adjust.

For first side: Select [MOTOR ADJ(FRONT)].

For second side: Select [MOTOR ADJ(BACK)].

Vérification de l'agrandissement

Vérifiez l'écart entre la ligne (1) de l'original (a) et la ligne (2) de l'exemple de copie. Si l'écart est supérieur à la valeur de référence, effectuez le réglage suivant.

Valeur de référence: $\pm 1,5\%$ max.

Réglage de l'agrandissement du DP

1. Passez en mode de maintenance et exécutez l'élément de maintenance U070 pour effectuer le réglage.

Pour le recto: Sélectionnez [MOTOR ADJ(FRONT)].

Pour le verso: Sélectionnez [MOTOR ADJ(BACK)].

Verificación del cambio de tamaño

Verifique la separación entre la línea (1) del original (a) y la línea (2) de la copia de muestra. Si la superación supera el valor de referencia, haga el siguiente ajuste.

Valor de referencia: Dentro de $\pm 1,5\%$

Ajuste del cambio de tamaño

1. Entre en el modo de mantenimiento e ingrese en el ítem de mantenimiento U070 para ajustar.

Para el primer lado: Seleccione [MOTOR ADJ(FRONT)].

Para el segundo lado: Seleccione [MOTOR ADJ(BACK)].

Überprüfen der Vergrößerung

Die Abweichung der Linie (1) des Originals (a) und der Linie (2) des Kopienmusters prüfen. Überschreitet die Abweichung den Bezugswert, ist die folgende Einstellung durchzuführen.

Bezugswert: Innerhalb $\pm 1,5\%$

Einstellen der DP-Vergrößerung

1. Den Wartungsmodus aktivieren, und den Wartungsposten U070 zur Einstellung ausführen.

Für erste Seite: [MOTOR ADJ(FRONT)] wählen.

Für zweite Seite: [MOTOR ADJ(BACK)] wählen.

Controllo dell'ingrandimento

Controllare la differenza tra la linea (1) dell'originale (a) e la linea (2) della copia di esempio. Se la differenza supera il valore di riferimento, effettuare la seguente regolazione.

Valore di riferimento: Entro $\pm 1,5\%$

Regolazione dell'ingrandimento DP

1. Entrare in modalità manutenzione e avviare la voce di manutenzione U070 per la regolazione.

Per il primo lato: selezionare [MOTOR ADJ(FRONT)].

Per il secondo lato: selezionare [MOTOR ADJ(BACK)].

确认等倍値

确认原稿 (a) 线 (1) 和复印样本线 (2) 的偏移。如果超过标准值时, 必须进行

调整。
< 标准值 > $\pm 1.5\%$ 以内

调整 DP 等倍値

1. 设定为 U070 保养模式, 进行调整。

表面时: 选择“MOTOR ADJ (FRONT)”。

背面时: 选择“MOTOR ADJ (BACK)”。

等倍度確認

原稿 (a) の線 (1) とコピーサンプルの線 (2) のずれを確認する。ずれが基準値外の場合は調整をおこなう。

< 基準値 > $\pm 1.5\%$ 以内

DP 等倍度調整

1. メンテナンスモード U070 をセットし、調整をおこなう。

表面の場合: 「MOTOR ADJ (FRONT)」を選択する。

裏面の場合: 「MOTOR ADJ (BACK)」を選択する。

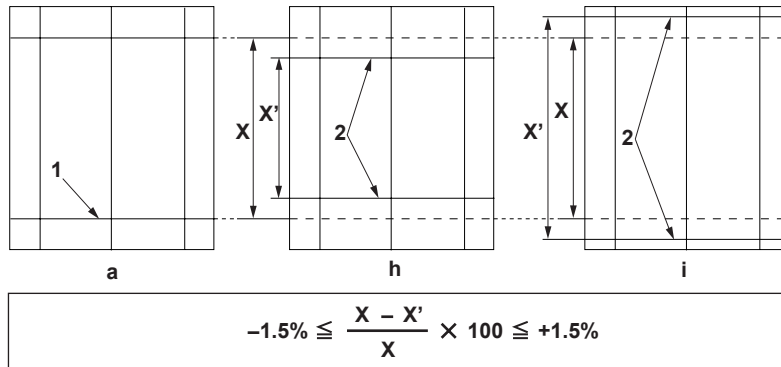

2. Change the setting value.

For copy example (h): Increase the setting value.
For copy example (i): Decrease the setting value.
Amount of change per step: 0.21 mm

3. Make a proof copy again.

4. Repeat steps 1 to 3 until line (2) of copy example shows the following the reference values.
Reference value: Within ±1.5 %

2. Changez la valeur de réglage.

Pour l'exemple de copie (h): Augmentez la valeur de réglage.
Pour l'exemple de copie (i): Diminuez la valeur de réglage.
Quantité de changement par pas: 0,21 mm

3. Effectuez à nouveau une copie de test.

4. Répétez les étapes 1 à 3 jusqu'à ce que la ligne (2) de l'exemple de copie corresponde aux valeurs de référence suivantes.
Valeur de référence: ±1,5% max.

2. Cambie el valor de configuración.

Para la copia de muestra (h): aumente el valor de configuración.
Para la copia de muestra (i): reduzca el valor de configuración.
Cantidad de cambio por paso: 0,21 mm

3. Haga otra copia de prueba.

4. Repita los pasos 1 a 3 hasta que la línea (2) de la copia de muestra tenga los siguientes valores de referencia.
Valor de referencia: Dentro de ±1,5 %

2. Den Einstellwert ändern.

Für Kopienmuster (h): Den Einstellwert erhöhen.
Für Kopienmuster (i): Den Einstellwert erniedrigen.
Änderungsbetrag pro Stufe: 0,21 mm

3. Eine erneute Probekopie anfertigen.

4. Die Schritte 1 bis 3 wiederholen, bis die Linie (2) des Kopienmusters die folgenden Bezugswerte aufweist.
Bezugswert: Innerhalb ±1,5 %

2. Cambiare il valore dell'impostazione.

Per un esempio di copia (h): aumentare il valore dell'impostazione.
Per un esempio di copia (i): diminuire il valore dell'impostazione.
Variazione graduale: 0,21 mm

3. Eseguire di nuovo una prova di copia.

4. Ripetere i passi da 1 a 3 fino a che la linea (2) dell'esempio di copia non mostra i seguenti valori di riferimento.
Valore di riferimento: Entro ±1,5 %

2. 調整設定値。

复印样本 (h) 时：提高设定值。
复印样本 (i) 时：降低设定值。
1 级的移动量：约 0.21mm

3. 再次进行测试复印。

4. 反复操作步骤 1 ~ 3, 直至复印样本的线 (2) 为标准值内。
<标准值> ± 1.5% 以内

2. 設定値を調整する。

コピーサンプル (h) の場合: 設定値を上げる
コピーサンプル (i) の場合: 設定値を下げる
1 ステップの変化量: 0.21mm

3. 再度テストコピーをおこなう。

4. コピーサンプルの線 (2) が基準値内になるまで、手順 1 ~ 3 を繰り返す。
<基準値> ± 1.5% 以内

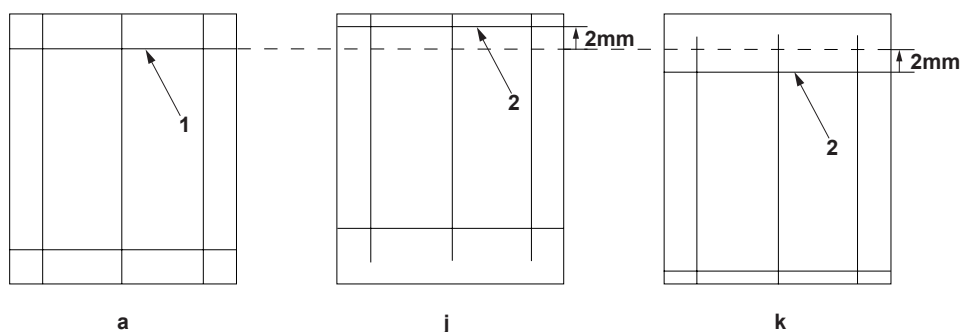

Checking the leading edge timing

Check the gap between line (1) of original (a) and line (2) of copy example. If the gap exceeds the reference value, perform the following adjustment.

Reference value: Within ± 2.0 mm

Adjusting the DP leading edge timing

1. Enter the maintenance mode and run the maintenance item U071 to adjust.

Select [FRONT HEAD] to adjust both the simplex and duplex copying at once.

(Use [BACK HEAD] only if you need to adjust the second side of duplex copying individually.)

Vérification de la synchronisation du bord avant

Vérifiez l'écart entre la ligne (1) de l'original (a) et la ligne (2) de l'exemple de copie. Si l'écart est supérieur à la valeur de référence, effectuez le réglage suivant.

Valeur de référence: $\pm 2,0$ max.

Réglage de la synchronisation du bord avant du DP

1. Passez en mode de maintenance et exécutez l'élément de maintenance U071 pour effectuer le réglage.

Sélectionnez [FRONT HEAD] pour régler en une seule fois la copie recto seul et la copie recto verso.

(Utilisez [BACK HEAD] uniquement si vous voulez régler individuellement le verso de la copie recto verso.)

Cambio de la sincronización de borde superior

Verifique la separación entre la línea (1) del original (a) y la línea (2) de la copia de muestra. Si la separación supera el valor de referencia, haga el siguiente ajuste.

Valor de referencia: Dentro de $\pm 2,0$ mm

Ajuste de la sincronización de borde superior del DP

1. Entre en el modo de mantenimiento e ingrese en el ítem de mantenimiento U071 para ajustar.

Seleccione [FRONT HEAD] para ajustar ambas copias simple y duplex al mismo tiempo.

(Utilice [BACK HEAD] sólo si necesita ajustar individualmente el segundo lado de la copia duplex.)

Überprüfen des Vorderkanten-Timings

Die Abweichung der Linie (1) des Originals (a) und der Linie (2) des Kopienmusters prüfen. Überschreitet die Abweichung den Bezugswert, ist die folgende Einstellung durchzuführen.

Bezugswert: Innerhalb $\pm 2,0$ mm

Einstellen des DP-Vorderkanten-Timings

1. Den Wartungsmodus aktivieren, und den Wartungsposten U071 zur Einstellung ausführen.

Wählen Sie [FRONT HEAD], um Simplex- und Duplexkopie auf einmal einzustellen.

(Verwenden Sie [BACK HEAD] nur, wenn die zweite Seite der Duplexkopie individuell eingestellt werden muss.)

Controllo della sincronizzazione del bordo principale

Controllare la differenza tra la linea (1) dell'originale (a) e la linea (2) della copia di esempio. Se la differenza supera il valore di riferimento, effettuare la seguente regolazione.

Valore di riferimento: Entro $\pm 2,0$ mm

Regolazione della sincronizzazione del bordo principale DP

1. Entrare in modalità manutenzione e avviare la voce di manutenzione U071 per la regolazione.

Selezionare [FRONT HEAD] per regolare simultaneamente entrambe le copie simplex e duplex.

(Usare [BACK HEAD] solo se è necessario regolare il secondo lato della copia duplex singolarmente.)

确认前端定时调整

确认原稿 (a) 线 (1) 和复印样本线 (2) 的偏移。如果超过标准值时, 必须进行

调整。
< 标准值 > ± 2.0 mm 以内

DP 前端定时调整

1. 设定为 U071 保养模式, 进行调整。

选择“FRONT HEAD”可同时调整单面和双面。
(仅在调整双面时的背面, 选择“BACK HEAD”。)

先端タイミング確認

原稿 (a) の線 (1) とコピーサンプルの線 (2) のずれを確認する。ずれが基準値外の場合は調整をおこなう。

< 基準値 > ± 2.0 mm 以内

DP 先端タイミング調整

1. メンテナンスモード U071 をセットし、調整をおこなう。

「FRONT HEAD」を選択する。(片面、両面表面が調整できる)
(両面裏面のみを調整する場合は、「BACK HEAD」を選択する。)

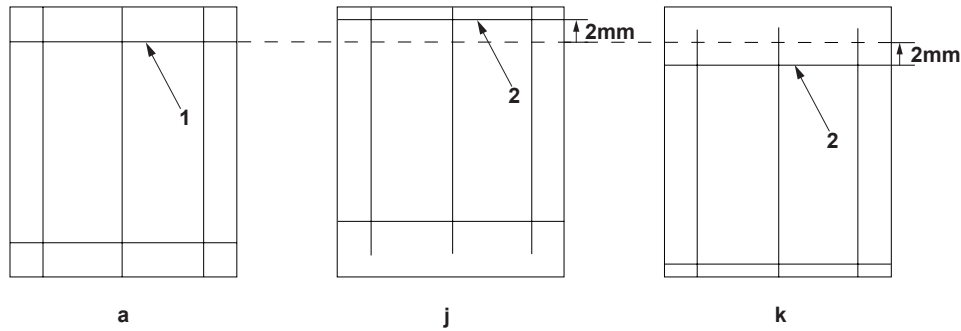

2. Change the setting value.

For copy example (j): Decrease the setting value.
For copy example (k): Increase the setting value.
Amount of change per step: 0.08 mm

3. Make a proof copy again.

4. Repeat steps 1 to 3 until line (2) of copy example shows the following the reference values.
Reference value: Within ± 2.0 mm

2. Changez la valeur de réglage.

Pour l'exemple de copie (j): Diminuez la valeur de réglage.
Pour l'exemple de copie (k): Augmentez la valeur de réglage.
Quantité de changement par pas: 0,08 mm

3. Effectuez à nouveau une copie de test.

4. Répétez les étapes 1 à 3 jusqu'à ce que la ligne (2) de l'exemple de copie corresponde aux valeurs de référence suivantes.
Valeur de référence: $\pm 2,0$ max.

2. Cambio del valor de configuración.

Para la copia de muestra (j): Reduzca el valor de configuración.
Para la copia de muestra (k): Aumente el valor de configuración.
Cantidad de cambio por paso: 0,08 mm

3. Haga otra copia de prueba.

4. Repita los pasos 1 a 3 hasta que la línea (2) de la copia de muestra tenga los siguientes valores de referencia.
Valor de referencia: Dentro de $\pm 2,0$ mm

2. Den Einstellwert ändern.

Für Kopienmuster (j): Den Einstellwert erniedrigen.
Für Kopienmuster (k): Den Einstellwert erhöhen.
Änderungsbetrag pro Stufe: 0,08 mm

3. Eine erneute Probekopie anfertigen.

4. Die Schritte 1 bis 3 wiederholen, bis die Linie (2) des Kopienmusters die folgenden Bezugswerte aufweist.
Bezugswert: Innerhalb $\pm 2,0$ mm

2. Cambio del valore d'impostazione.

Per un esempio di copia (j): Diminuire il valore d'impostazione.
Per un esempio di copia (k): Aumentare il valore d'impostazione.
Variazione graduale: 0,08 mm

3. Eseguire di nuovo una prova di copia.

4. Ripetere i passi da 1 a 3 fino a che la linea (2) dell'esempio di copia non mostra i seguenti valori di riferimento.
Valore di riferimento: Entro $\pm 2,0$ mm

2. 調整設定値。

复印样本 (j) 时：提高设定值。
复印样本 (k) 时：降低设定值。
1 级的移动量：约 0.08mm

3. 再次进行测试复印。

4. 反复操作步骤 1 ~ 3, 直至复印样本的线 (2) 为标准值内。
<标准值> ± 2.0 mm 以内

2. 設定値を調整する。

コピーサンプル (j) の場合：設定値を下げる
コピーサンプル (k) の場合：設定値を上げる
1 ステップの変化量：0.08mm

3. 再度テストコピーをおこなう。

4. コピーサンプルの線 (2) が基準値内になるまで、手順 1 ~ 3 を繰り返す。
<基準値> ± 2.0 mm 以内

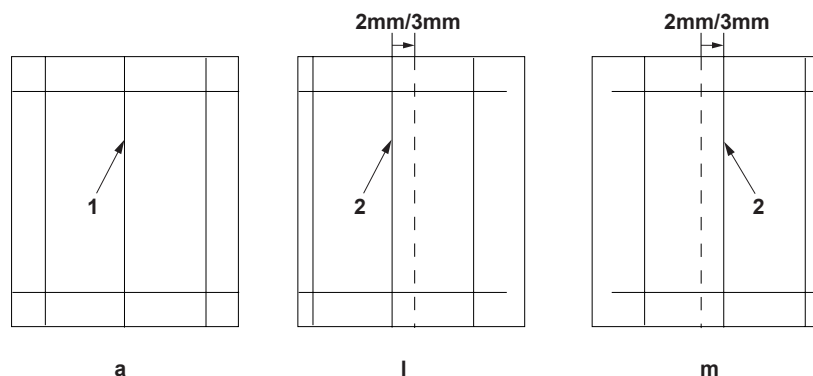

Checking the center line

Check the gap between line (1) of original (a) and line (2) of copy example. If the gap exceeds the reference value, perform the following adjustment.

<Reference value>

For simplex copying: Within ± 2.0 mm

For duplex copying: Within ± 3.0 mm

Adjusting the DP center line

1. Enter the maintenance mode and run the maintenance item U072 to adjust.

Select [FRONT] to adjust both the simplex and duplex copying at once. (Use [BACK] only if you need to adjust the second side of duplex copying individually.)

Vérification de la ligne médiane

Vérifiez l'écart entre la ligne (1) de l'original (a) et la ligne (2) de l'exemple de copie. Si l'écart est supérieur à la valeur de référence, effectuez le réglage suivant.

<Valeur de référence>

Copie recto seul: $\pm 2,0$ mm max.

Copie recto verso: $\pm 3,0$ mm max.

Réglage de la ligne médiane du DP

1. Passez en mode de maintenance et exécutez l'élément de maintenance U072 pour effectuer le réglage.

Sélectionnez [FRONT] pour régler en une seule fois la copie recto seul et la copie recto verso.

(Utilisez [BACK] uniquement si vous voulez régler individuellement le verso de la copie recto verso.)

Verificación de la línea central

Verifique la separación entre la línea (1) del original (a) y la línea (2) de la copia de muestra. Si la superación supera el valor de referencia, haga el siguiente ajuste.

<Valor de referencia>

Para copia simple: Dentro de $\pm 2,0$ mm

Para copia duplex: Dentro de $\pm 3,0$ mm

Ajuste de la línea central del DP

1. Entre en el modo de mantenimiento e ingrese en el ítem de mantenimiento U072 para ajustar.

Seleccione [FRONT] para ajustar ambas copias simple y duplex al mismo tiempo.

(Utilice [BACK] sólo si necesita ajustar individualmente el segundo lado de la copia duplex.)

Überprüfen der Mittellinie

Die Abweichung der Linie (1) des Originals (a) und der Linie (2) des Kopienmusters prüfen. Überschreitet die Abweichung den Bezugswert, ist die folgende Einstellung durchzuführen.

<Bezugswert>

Für Simplexkopie: Innerhalb $\pm 2,0$ mm

Für Duplexkopie: Innerhalb $\pm 3,0$ mm

Einstellen der DP-Mittellinie

1. Den Wartungsmodus aktivieren, und den Wartungsposten U072 zur Einstellung ausführen.

Wählen Sie [FRONT], um Simplex- und Duplexkopie auf einmal einzustellen.

(Verwenden Sie [BACK] nur, wenn die zweite Seite der Duplexkopie individuell eingestellt werden muss.)

Controllo della linea centrale

Controllare la differenza tra la linea (1) dell'originale (a) e la linea (2) della copia di esempio. Se la differenza supera il valore di riferimento, effettuare la seguente regolazione.

<Valore di riferimento>

Per copia simplex: Entro $\pm 2,0$ mm

Per copia duplex: Entro $\pm 3,0$ mm

Regolazione della linea centrale del DP

1. Entrare in modalità manutenzione e avviare la voce di manutenzione U072 per la regolazione.

Selezionare [FRONT] per regolare simultaneamente entrambe le copie simplex e duplex.

(Usare [BACK] solo se è necessario regolare il secondo lato della copia duplex singolarmente.)

确认中心线

确认原稿 (a) 线 (1) 和复印样本线 (2) 的偏移。如果超过标准值时, 必须进行

调整。

<标准值>

单面时: ± 2.0 mm 以内

双面时: ± 3.0 mm 以内

调整 DP 中心线

1. 选定保养模式 U072, 进行调整。

选择“FRONT”可同时调整单面和双面。

(仅在调整双面时的背面, 选择“BACK”。)

センターライン確認

原稿 (a) のセンターライン (1) とコピーサンプルのセンターライン (2) のずれを確認する。ずれが基準値外の場合は調整をおこなう。

<基準値>

片面の場合: ± 2.0 mm 以内

両面の場合: ± 3.0 mm 以内

DP センターライン調整

1. メンテナンスモード U072 をセットし、調整をおこなう。

「FRONT」を選択する。(片面、両面表面が調整できる)

(両面裏面のみを調整する場合は、「BACK」を選択する。)

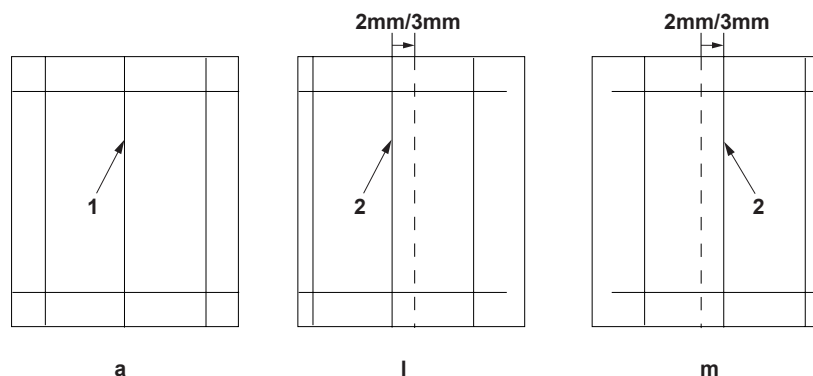

2. Change the setting value.

For copy example (l): Increase the setting value.
For copy example (m): Decrease the setting value.
Amount of change per step: 0.08 mm

3. Make a proof copy again.

4. Repeat steps 1 to 3 until line (2) of copy example shows the following the reference values.

<Reference value>

For simplex copying: Within ± 2.0 mm

For duplex copying: Within ± 3.0 mm

2. Changez la valeur de réglage.

Pour l'exemple de copie (l): Augmentez la valeur de réglage.
Pour l'exemple de copie (m): Diminuez la valeur de réglage.
Quantité de changement par pas: 0,08 mm

3. Effectuez à nouveau une copie de test.

4. Répétez les étapes 1 à 3 jusqu'à ce que la ligne (2) de l'exemple de copie corresponde aux valeurs de référence suivantes.

<Valeur de référence>

Copie recto seul: $\pm 2,0$ mm max.

Copie recto verso: $\pm 3,0$ mm max.

2. Cambie el valor de configuración.

Para la copia de muestra (l): Aumente el valor de configuración.
Para la copia de muestra (m): Reduzca el valor de configuración.
Cantidad de cambio por paso: 0,08 mm

3. Haga otra copia de prueba.

4. Repita los pasos 1 a 3 hasta que la línea (2) de la copia de muestra tenga los siguientes valores de referencia.

<Valor de referencia>

Para copia simple: Dentro de $\pm 2,0$ mm

Para copia duplex: Dentro de $\pm 3,0$ mm

2. Den Einstellwert ändern.

Für Kopienmuster (l): Den Einstellwert erhöhen.
Für Kopienmuster (m): Den Einstellwert erniedrigen.
Änderungsbetrag pro Stufe: 0,08 mm

3. Eine erneute Probekopie anfertigen.

4. Die Schritte 1 bis 3 wiederholen, bis die Linie (2) des Kopienmusters die folgenden Bezugswerte aufweist.

<Bezugswert>

Für Simplexkopie: Innerhalb $\pm 2,0$ mm

Für Duplexkopie: Innerhalb $\pm 3,0$ mm

2. Cambiare il valore dell'impostazione.

Per un esempio di copia (l): Aumentare il valore dell'impostazione.
Per un esempio di copia (m): Diminuire il valore dell'impostazione.
Variazione graduale: 0,08 mm

3. Eseguire di nuovo una prova di copia.

4. Ripetere i passi da 1 a 3 fino a che la linea (2) dell'esempio di copia non mostra i seguenti valori di riferimento.

<Valore di riferimento>

Per copia simplex: Entro $\pm 2,0$ mm

Per copia duplex: Entro $\pm 3,0$ mm

2. 調整設定値。

复印样本 (l) 时: 提高设定值。
复印样本 (m) 时: 降低设定值。
1 级的移动量: 约 0.08mm

3. 再次进行测试复印。

4. 反复操作步骤 1 ~ 3, 直至复印样本的线 (2) 为标准值内。

<标准值>

单面时: ± 2.0 mm 以内

双面时: ± 3.0 mm 以内

2. 設定値を調整する。

コピーサンプル (l) の場合: 設定値を上げる
コピーサンプル (m) の場合: 設定値を下げる
1 ステップの変化量: 0.08mm

3. 再度テストコピーをおこなう。

4. コピーサンプルのセンターライン (2) が基準値内になるまで、手順 1 ~ 3 を繰り返す。

<基準値>

片面の場合: ± 2.0 mm 以内

両面の場合: ± 3.0 mm 以内

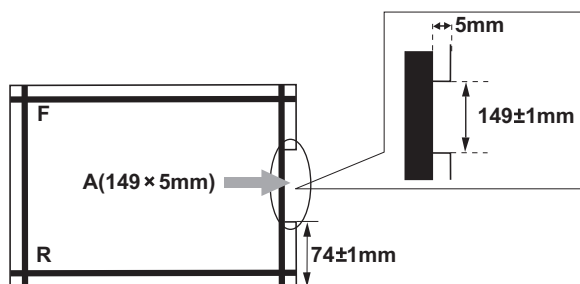

Automatic adjustment using the original for adjustment

Before performing this adjustment, be sure to adjust the angle of leading edge and the angle of trailing edge (see pages 7 and 10).

1. Cut the trailing edge of an original for adjustment as shown in a figure.
2. Place the original for adjustment in the DP with the F and R surface up.
3. Enter the maintenance mode and run the maintenance item U411. Select [DP(FACE UP)], press [INPUT] and then press the start key. Adjustments of the DP magnification, DP leading edge timing and DP center line are performed automatically.
4. When [Complete] is displayed, the adjustments are properly completed. If a problem occurs during automatic adjustments, [XX] (XX is replaced with an error code) is displayed.
Check the original set position and repeat the steps 2 to 3 until [Complete] is displayed. For details, see the service manual.

Réglage automatique en utilisant l'original pour effectuer le réglage

Avant d'effectuer ce réglage, veiller à régler l'angle du bord avant et l'angle du bord arrière (se reporter aux pages 7 et 10).

1. Découpez le bord arrière de l'original utilisé pour le réglage comme indiqué sur l'illustration.
2. Placez l'original utilisé pour le réglage dans le DP, en orientant les surfaces F et R vers le haut.
3. Passez en mode de maintenance et exécutez l'élément de maintenance U411. Sélectionnez [DP(FACE UP)], appuyez sur [INPUT], puis appuyez sur la touche de démarrer.
Les réglages de l'agrandissement du DP, de la synchronisation du bord avant du DP et de la ligne médiane du DP sont alors effectués automatiquement.
4. Lorsque [Complete] s'affiche, les réglages ont été accomplis correctement. Si une anomalie se produit pendant la réalisation des réglages automatiques, le message [XX] (XX désignant le code d'erreur) s'affiche.
Vérifiez la position de mise en place de l'original et répétez les étapes 2 et 3 jusqu'à ce que [Complete] s'affiche. Pour plus de détails, reportez-vous au manuel de service.

Ajuste automático utilizando el original para el ajuste

Antes de hacer el ajuste, asegúrese de ajustar el ángulo del borde superior y el ángulo del borde inferior (vea las páginas 7 y 10).

1. Corte el borde inferior de un original para el ajuste como se indica en la figura.
2. Coloque el original para el ajuste en el DP con la superficie F y R arriba.
3. Entre en el modo de mantenimiento e ingrese en el ítem de mantenimiento U411. Seleccione [DP(FACE UP)], presione [INPUT] y presione la tecla de inicio.
Los ajustes de cambio de tamaño de DP, sincronización de borde superior d DP y línea central de DP se hacen automáticamente.
4. Cuando aparece [Complete], se completa correctamente el ajuste. Si se produce un problema durante los ajustes automáticos, aparece [XX] (donde XX cambia por un código de error).
Verifique la posición de colocación del original y repita los pasos 2 a 3 hasta que aparezca [Complete]. Para más detalles, vea el manual de servicio.

Automatische Einstellung mithilfe des Originals

Bevor diese Einstellung durchgeführt wird, muss der Winkel der Vorder- und Hinterkante eingestellt werden (siehe die Seiten 7 und 10).

1. Die Vorderkante eines Originals für die Einstellung einschneiden, wie in der Abbildung gezeigt.
2. Das Original für die Einstellung mit der Fläche F und R nach oben in den DP einlegen.
3. Den Wartungsmodus aktivieren, und den Wartungsposten U411 ausführen. [DP(FACE UP)] wählen, [INPUT] drücken, und dann die Start drücken.
Die Einstellungen von DP-Vergrößerung, DP-Vorderkanten-Timing und DP-Mittellinie werden automatisch durchgeführt.
4. Wenn [Complete] angezeigt wird, sind die Einstellungen ordnungsgemäß abgeschlossen. Falls während der automatischen Einstellungen eine Störung auftritt, wird [XX] (XX wird durch einen Fehlercode ersetzt) angezeigt.
Die Original-Einlegeposition überprüfen, und die Schritte 2 bis 3 wiederholen, bis [Complete] angezeigt wird. Einzelheiten sind der Wartungsanleitung zu entnehmen.

Regolazione automatica eseguita con l'originale

Prima di eseguire questa regolazione, verificare che l'angolo del bordo principale e l'angolo del bordo di uscita siano regolati (vedere le pagine 7 e 10).

1. Tagliare il bordo di uscita di un originale per la regolazione come si vede nel disegno.
2. Collocare l'originale per la regolazione nel DP con la superficie F e R rivolta verso l'alto.
3. Entrare in modalità manutenzione e avviare la voce di manutenzione U411. Selezionare [DP(FACE UP)], premere [INPUT] e poi premere il tasto di avvio.
Le regolazioni dell'ingrandimento DP, della sincronizzazione del bordo principale e della linea centrale del DP saranno eseguite automaticamente.
4. Quando [Complete] viene visualizzato, le regolazioni sono state completate correttamente. Se durante le regolazioni automatiche si verifica qualche problema, nel display viene visualizzato [XX] (XX viene sostituito da un codice di errore).
Controllare la posizione d'impostazione dell'originale e ripetere i passi da 2 a 3 fino a che [Complete] non viene visualizzato. Per ulteriori dettagli, vedere il manuale d'istruzioni.

通过调整用原稿进行自动调整

先完成前端倾斜和后端倾斜的调整后,再进行以下操作。(参照第7页和第10页)

1. 按图所示切断调整用原稿的后端。
2. 记有 F 和 R 的面朝上,将调整用原稿放在 DP 上。
3. 选定保养模式 U411。选择“DP(FACE UP)”,按下“INPUT”,再按下开始键。
自动进行等倍值、前端定时、中心线的调整。
4. 自动调整正常结束时显示出“Complete”表示。执行调整中发生异常时、显示出“XX”。
确认原稿设定位置后,再次进行调整(详情请参照维修手册)。

調整用原稿による自動調整

先端斜め調整および後端斜め調整をおこなってから実施する。(7 ページ、10 ページ参照)

1. 調整用原稿の後端をイラストのようにカットする。
2. F・R が記載されている面を上にして、調整用原稿を DP にセットする。
3. メンテナンスモード U411 をセットする。「DP(FACE UP)」を選択し、「INPUT」を押して次にスタートキーを押す。
等倍度・先端タイミン・センターライン調整が自動的におこなわれる。
4. 自動調整が正常に終了すると「Complete」が表示される。調整実行中にエラーが発生した場合は、「XX」が表示される。
原稿のセット位置を確認し、再度調整をおこなう(詳細はサービスマニュアル参照)。

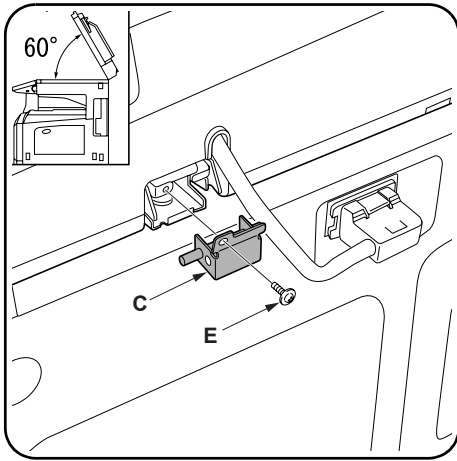

Adjusting the DP open/close angle
To adjust the DP open/close angle to 60 degrees

1. Insert the angle adjusting plate (C) and fit it using M4 x 14 screw (E).

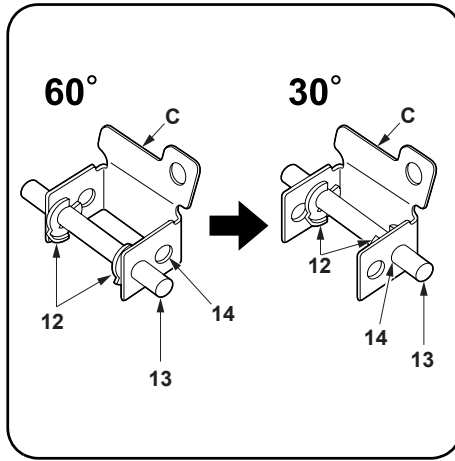

To adjust the DP open/close angle to 30 degrees

1. Remove two stop rings (12) and pull the shaft (13) out.
2. Insert the shaft (13) into the holes (14) and refit two stop rings (12).

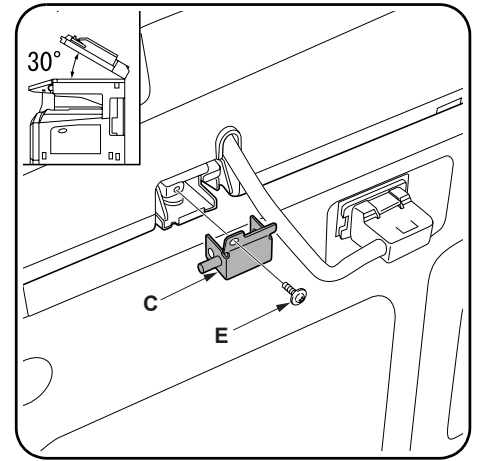

3. Insert the angle adjusting plate (C) and fit it using M4 x 14 screw (E).

Réglage de l'angle d'ouverture/fermeture du DP

Pour régler l'angle d'ouverture/fermeture du DP à 60 degrés

1. Insérez la plaque de réglage d'angle (C), et fixez-la à l'aide d'une vis M4 x 14 (E).

Pour régler l'angle d'ouverture/fermeture du DP à 30 degrés

1. Retirez deux bagues d'arrêt (12) et tirez l'arbre (13) vers l'extérieur.
2. Insérez l'arbre (13) dans les orifices (14) et remettez les deux bagues d'arrêt (12) en place.

3. Insérez la plaque de réglage d'angle (C), et fixez-la à l'aide d'une vis M4 x 14 (E).

Ajuste del ángulo de apertura/cierre del DP

Para ajustar el ángulo de apertura/cierre del DP a 60 grados

1. Inserte la placa de ajuste de ángulo (C) y fije con el tornillo M4 x 14 (E).

Para ajustar el ángulo de apertura/cierre del DP a 30 grados

1. Desmonte los dos aros de tope (12) y tire del eje (13) hacia fuera.
2. Inserte el eje (13) en los orificios (14) y vuelva a colocar los dos aros de tope (12).

3. Inserte la placa de ajuste de ángulo (C) y fije con el tornillo M4 x 14 (E).

Einstellen des DP-Öffnungs-/Schließungswinkels

Einstellung des DP-Öffnungs-/Schließungswinkels auf 60 Grad

1. Den Winkeleinstellhalter (C) einsetzen und mit einer M4 x 14 Schraube (E) befestigen.

Einstellung des DP-Öffnungs-/Schließungswinkels auf 30 Grad

1. Die zwei Sicherungsringe (12) entfernen, und die Achse (13) herausziehen.
2. Die Achse (13) in die Löcher (14) einführen, und die zwei Sicherungsringe (12) wieder anbringen.

3. Den Winkeleinstellhalter (C) einsetzen und mit einer M4 x 14 Schraube (E) befestigen.

Regolazione dell'angolo di apertura e chiusura del DP

Per regolare l'angolo di apertura e chiusura del DP a 60 gradi

1. Inserire la piastra di regolazione dell'angolo (C) e fissarla con una vite M4 x 14 (E).

Per regolare l'angolo di apertura e chiusura del DP a 30 gradi

1. Rimuovere i due anelli di arresto (12) ed estrarre l'albero (13).
2. Inserire l'albero (13) nei fori (14) e fissare nuovamente i due anelli di arresto (12).

3. Inserire la piastra di regolazione dell'angolo (C) e fissarla con una vite M4 x 14 (E).

调整 DP 的开关角度

当 DP 的开关角度为 60° 时

1. 插入调整板 (C), 用 1 个螺丝 M4 x 14 (E) 进行固定。

当 DP 的开关角度为 30° 时

1. 拆下 2 个止动环 (12), 拔下轴 (13)。
2. 将轴 (13) 插入孔 (14), 并将 2 个止动环 (12) 按原样装好。

3. 插入调整板 (C), 用 1 个螺丝 M4 x 14 (E) 进行固定。

DP 開閉角度の調整

DP 開閉角度を 60° に設定する場合

1. 調整板 (C) を挿入し、ビス M4 x 14 (E) 1 本で固定する。

DP 開閉角度を 30° に設定する場合

1. ストップリング (12) 2 個を外し、軸 (13) を引き抜く。
2. 軸 (13) を穴 (14) に挿入し、ストップリング (12) 2 個を元通り取り付け。

3. 調整板 (C) を挿入し、ビス M4 x 14 (E) 1 本で固定する。

INSTALLATION GUIDE FOR PAPER FEEDER

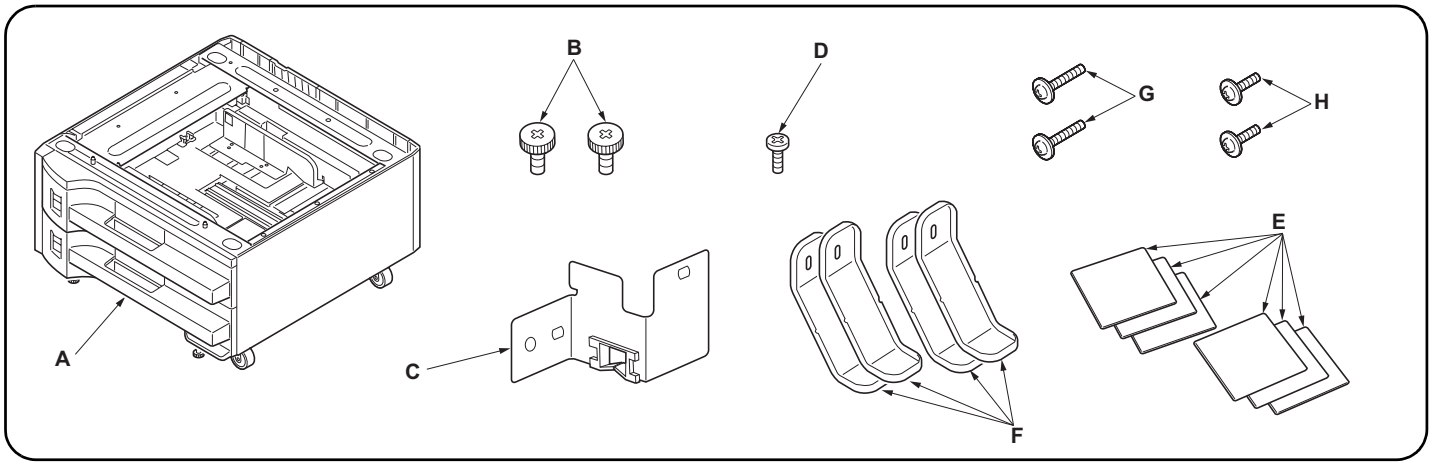

English

Supplied parts

A Paper feeder	1
B Pin	2
C Joint plate	1
D M3 × 6 screw	1

E Paper size card	6
F Stay	4
G M4 × 20 screw	2
H M4 × 10 screw	2

Use the paper size card (E) which is the same specification paper size used in the machine.

Français

Pièces fournies

A Bureau papier	1
B Broches	2
C Plaque de raccord	1
D Vis M3 × 6	1

E Cartes de format de papier	6
F Supports	4
G Vis M4 × 20	2
H Vis M4 × 10	2

Utiliser la carte de format de papier (E) possédant le même format de papier que celui spécifié pour la machine.

Español

Partes suministradas

A Alimentador de papel	1
B Clavija	2
C Placa de unión	1
D Tornillo M3 × 6	1

E Tarjeta de tamaño de papel	6
F Base	4
G Tornillo M4 × 20	2
H Tornillo M4 × 10	2

Utilice la tarjeta de tamaño de papel (E) que sea del mismo tamaño de papel especificado utilizado en la máquina.

Deutsch

Gelieferte Teile

A Papiereinzug	1
B Stift	2
C Verbindungsplatte	1
D M3 × 6 Schraube	1

E Papierformatkarte	6
F Stütze	4
G M4 × 20 Schraube	2
H M4 × 10 Schraube	2

Benutzen Sie die Papierformatkarte (E), deren Format mit demjenigen des für die Maschine vorgeschriebenen Papiers übereinstimmt.

Italiano

Parti di fornitura

A Unità di alimentazione della carta	1
B Perno	2
C Piastra di giunzione	1
D Vite M3 × 6	1

E Scheda formato carta	6
F Sospensione	4
G Vite M4 × 20	2
H Vite M4 × 10	2

Utilizzare la scheda formato carta (E) corrispondente al formato carta utilizzato nella macchina.

简体中文

附属品

A 供纸盒	1
B 固定插销	2
C 连接金属件	1
D 螺丝 M3 × 6	1

E 纸张尺寸卡片	6
F 防倒金属件	4
G 螺丝 M4 × 20	2
H 螺丝 M4 × 10	2

请使用与机器本体的用纸尺寸相同规格的纸张尺寸卡片 (E)。

日本語

同梱品

A ペーパーフィーダ	1
B ピン	2
C 接続金具	1
D ビス M3 × 6	1

E 用紙シート	6
F 転倒防止金具 (100V 仕様では使用しない)	4
G ビス M4 × 20 (100V 仕様では使用しない)	2
H ビス M4 × 10 (100V 仕様では使用しない)	2

用紙シート (E) は、機械本体の用紙サイズと同じ仕様のシートを使用してください。

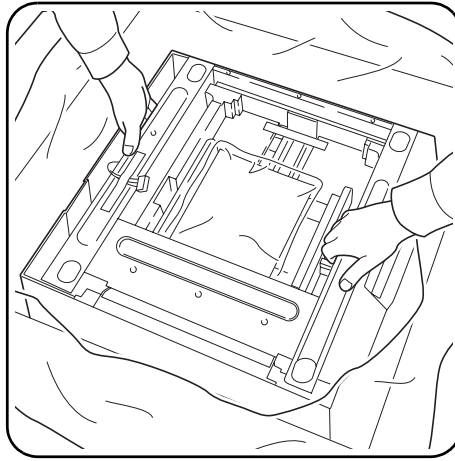

Precaution for unpacking

Hold the positions shown in the figure and remove the paper feeder from the outer case.

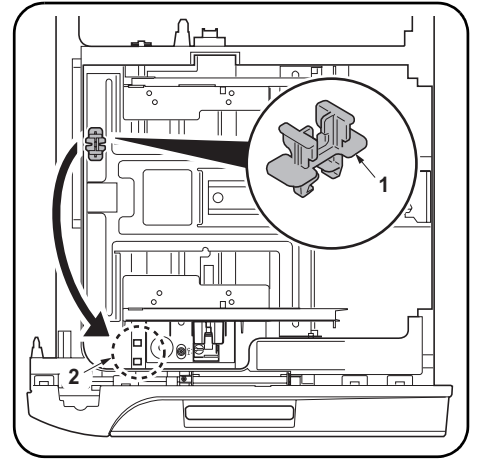

Procedure

Releasing lift plate stopper

1. Pull each cassette out and then remove the lift plate stopper (1) from each cassette and attach it to the storage location (2).
2. Gently close each cassette.

Precautions

- Be sure to remove any tape and/or cushioning material from supplied parts.
- Before installing the paper feeder, be sure to turn the main power switch of the machine off and unplug the power cable from the wall outlet.

Précautions

- Veillez à retirer les morceaux de bande adhésive et/ou les matériaux de rembourrage des pièces fournies.
- Avant d'installer le bureau papier, veillez à mettre la machine hors tension et à débrancher le câble d'alimentation de la prise murale.

Précaution pour le déballage

Saisir les emplacements indiqués sur l'illustration et retirer le bureau papier du boîtier extérieur.

Procédure

Libération de la butée de plaque d'élévation

1. Tirer chaque tiroir vers l'extérieur puis retirer la butée de plaque d'élévation (1) de chaque tiroir et la fixer à l'emplacement de rangement (2).
2. Refermer progressivement chaque tiroir.

Precauciones

- Asegúrese de despegar todas las cintas y/o material amortiguador de las partes suministradas.
- Antes de instalar el alimentador de papel, asegúrese de desconectar el interruptor principal de la máquina y desenchufar el cable eléctrico del tomacorriente de la pared.

Precauciones para el desembalaje

Sujete por las posiciones indicadas en la figura y desmonte el alimentador de papel de la caja de embalaje.

Procedimiento

Soltado del tope de placa de elevación

1. Abra la bandeja y quite el tope de la placa de elevación (1) de cada bandeja y colóquela en su lugar de depósito (2).
2. Cierre suavemente cada bandeja.

Vorsichtsmaßnahmen

- Entfernen Sie Klebeband und/oder Dämpfungsmaterial vollständig von den mitgelieferten Teilen.
- Schalten Sie unbedingt den Betriebsschalter der Maschine aus, und trennen Sie das Netzkabel von der Netzsteckdose, bevor Sie den Papiereinzug installieren.

Vorsichtsmaßnahme beim Auspacken

Halten Sie den Papiereinzug an den in der Abbildung gezeigten Stellen, und heben Sie ihn aus dem äußeren Karton heraus.

Verfahren

Lösen des Hebeplattenanschlages

1. Die einzelnen Kassetten herausziehen, dann den Hebeplattenanschlag (1) von jeder Kassette entfernen und an der Speicherposition (2) anbringen.
2. Alle Kassetten sanft schließen.

Precauzioni

- Accertarsi di rimuovere tutti i nastri adesivi e/o il materiale di imbottitura dalle parti fornite.
- Prima di installare l'unità di alimentazione della carta, assicurarsi di spegnere l'interruttore principale di alimentazione della macchina e scollegare la spina del cavo di alimentazione dalla presa a muro della rete elettrica.

Precauzioni per il disinballaggio

Mantenere le posizioni indicate nella figura e rimuovere l'unità di alimentazione della carta dall'involucro esterno.

Procedura

Rimozione del fermo della piastra di sollevamento

1. Estrarre ciascun cassetto e poi rimuovere il fermo della piastra di sollevamento (1) da ciascun cassetto e fissarlo nella posizione di immagazzinaggio (2).
2. Chiudere delicatamente ciascun cassetto.

注意事項

- 如果附属品上带有固定胶带、缓冲材料时务必揭下。
- 安装供纸盒时，必须先关闭机器主机上的主电源开关，并拔下电源插头后再进行工作。

开包时的注意事项

开箱时，按图示位置把供纸盒从外箱中取出。

安装步骤

解除升降板的固定

1. 拉出各供纸盒，拆下各 1 个升降板挡块 (1)，并存放在如图所示的保管场所 (2) 里。
2. 轻轻地推入各供纸盒。

注意事項

- 同梱品に固定テープ、緩衝材が付いている場合は必ず取り外すこと。
- ペーパーフィーダを設置する場合は、機械本体の主電源スイッチを OFF にし、電源プラグを抜いてから作業をおこなう。

開梱時の注意

開梱時は、イラストの位置を持って外ケースから取り出す。

設置手順

リフト板の固定解除

1. 各カセットを引き出し、リフト板ストッパー (1) 各 1 個を外して保管場所 (2) に取り付ける。
2. 各カセットを静かに押し込む。

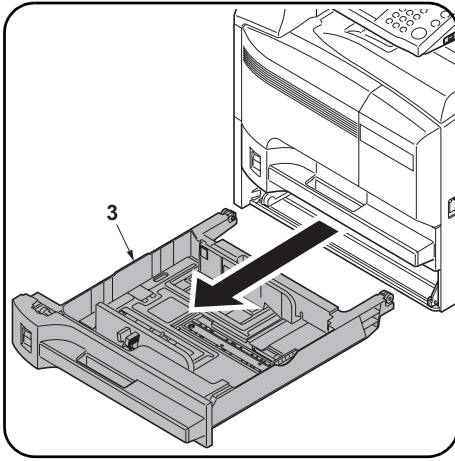

Installing the paper feeder

3. Pull out and remove cassette 2 (3) from the machine.

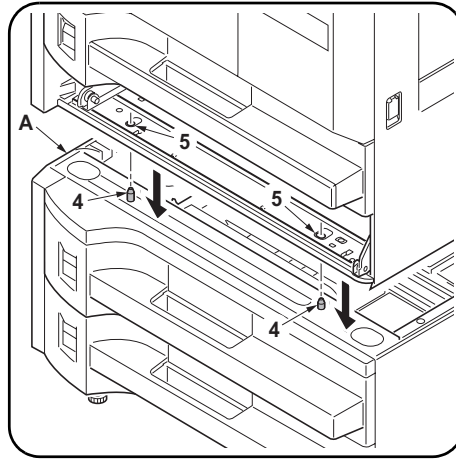

4. Place the machine on the paper feeder (A) to fit the positioning pins (4) at the front left and right of the paper feeder to the holes (5) in the machine.

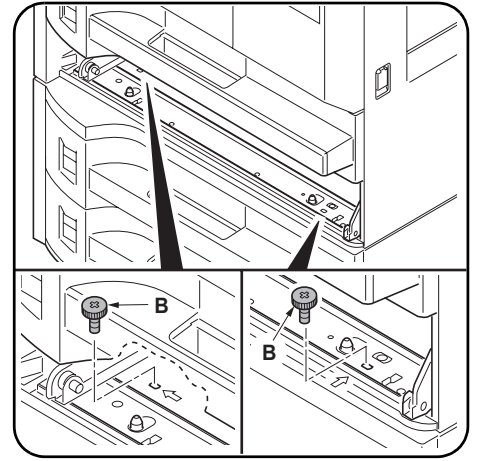

5. Fix the machine using two pins (B).
6. Insert cassette 2 (3) into the machine.

Installation du bureau papier

3. Tirer le tiroir 2 (3) hors de la machine.

4. Placer la machine sur le bureau papier (A) pour engager les broches de positionnement (4) situées des côtés avant gauche et droit du bureau papier dans les orifices (5) de la machine.

5. Fixer la machine à l'aide de deux broches (B).
6. Insérer le tiroir 2 (3) dans la machine.

Instalación del alimentador de papel

3. Quite y desmonte la bandeja 2 (3) de la máquina.

4. Coloque la máquina sobre el alimentador de papel (A) para que se introduzcan las clavijas de posicionamiento (4) en el lado delantero izquierdo y derecho del alimentador de papel en los orificios (5) en la máquina.

5. Fije la máquina utilizando dos clavijas (B).
6. Coloque la bandeja 2 (3) en la máquina.

Installieren des Papiereinzugs

3. Die Kasette 2 (3) herausziehen und von der Maschine entfernen.

4. Die Maschine so auf den Papiereinzug (A) setzen, dass die Passstifte (4) auf der linken und rechten Vorderseite des Papiereinzugs in den Löchern (5) der Maschine sitzen.

5. Die Maschine mit den zwei Stiften (B) befestigen.
6. Die Kasette 2 (3) in die Maschine einsetzen.

Installazione dell'unità di alimentazione della carta

3. Estrarre e rimuovere il cassetto 2 (3) dalla macchina.

4. Installare la macchina sopra l'unità di alimentazione della carta (A) in modo da mantenere i perni di posizionamento (4) situati sul lato anteriore sinistro e destro dell'unità di alimentazione della carta stessa allineati ai fori (5) nella macchina.

5. Fissare la macchina utilizzando due perni (B).
6. Inserire il cassetto 2 (3) nella macchina.

供紙盒的安装

3. 取出机器主机上的供纸盒 2 (3)。

4. 供纸盒前侧的左右插销 (4) 分别对准机器主机的各相应销孔 (5) 后, 将机器主机放在供纸盒 (A) 上。

5. 用 2 个固定插销 (B) 固定机器主机。
6. 将供纸盒 2 (3) 装回原来的位置。

ペーパーフィーダの設置

3. 機械本体のカセット 2 (3) を引き抜く。

4. ペーパーフィーダ前側の左右のピン (4) と機械本体の穴 (5) が一致するように、機械本体をペーパーフィーダ (A) にのせる。

5. ピン (B) 2 本で機械本体を固定する。
6. カセット 2 (3) を元通り挿入する。

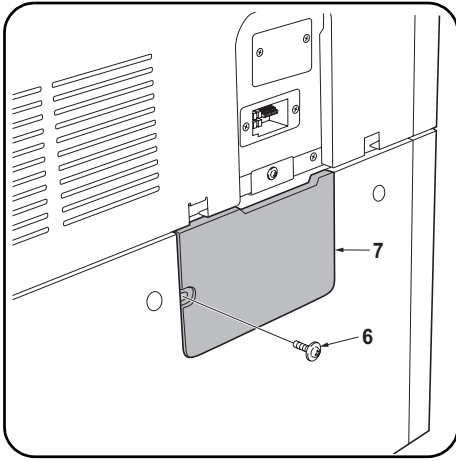

7. Remove the screw (6) at the rear side of the paper feeder to remove the cover (7).

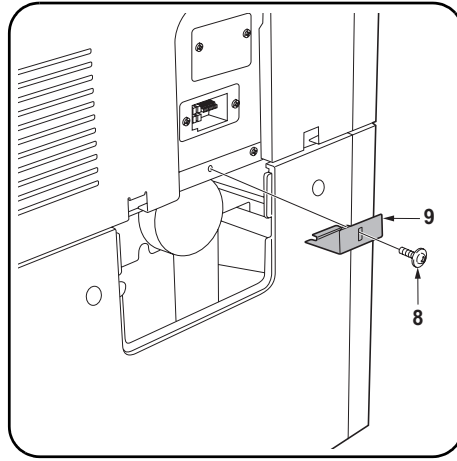

8. Remove the screw (8) to remove the metal plate (9).
The removed metal plate (9) is no longer required.

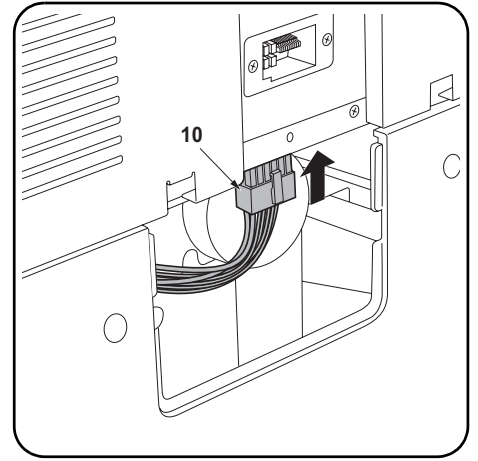

9. Connect the connector (10) to the machine.

7. Retirer la vis (6) située sur le côté arrière du bureau papier pour retirer le couvercle (7).

8. Retirer la vis (8) pour déposer la plaque métallique (9).
La plaque métallique déposée (9) n'est plus nécessaire.

9. Brancher le connecteur (10) à la machine.

7. Quite el tornillo (6) en el lado trasero del alimentador de papel para desmontar la tapa (7).

8. Quite el tornillo (8) para desmontar la placa de metal (9).
La placa de metal desmontada (9) ya no es necesaria.

9. Conecte el conector (10) en la máquina.

7. Die Schraube (6) auf der Rückseite des Papiereinzugs herausdrehen, um die Abdeckung (7) abzunehmen.

8. Die Schraube (8) herausdrehen, um die Metallplatte (9) abzunehmen.
Die abgenommene Metallplatte (9) wird nicht mehr benötigt.

9. Den Steckverbinder (10) an die Maschine anschließen.

7. Rimuovere la vite (6) dal retro dell'unità di alimentazione della carta per togliere il coperchio (7).

8. Rimuovere la vite (8) per togliere la piastra di metallo (9).
La piastra di metallo (9) rimossa non è più necessaria.

9. Collegare il connettore (10) alla macchina.

7. 拆除供纸盒后侧的 1 个螺丝 (6), 拆下盖板 (7)。

8. 拆除 1 个螺丝 (8), 拆下金属件 (9)。
不要安装金属件 (9)。

9. 将接头 (10) 连接在机器主机上。

7. ペーパーフィーダ後側のビス (6) 1 本を外し、カバー (7) を取り外す。

8. ビス (8) 1 本を外し、金具 (9) を取り外す。
金具 (9) は取り付けない。

9. コネクタ (10) を機械本体に接続する。

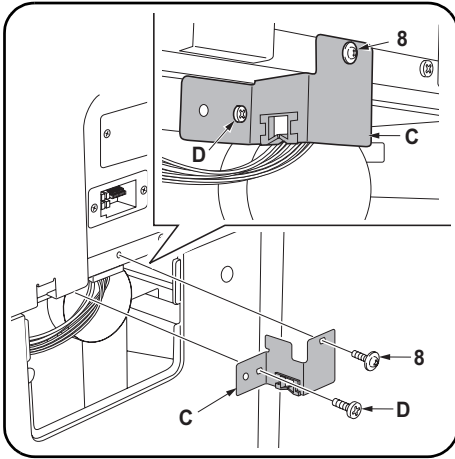

10. Attach the joint plate (C) using two screws.
Right: Use the screw (8) removed in step 8
Left: Use M3 × 6 screw (D)

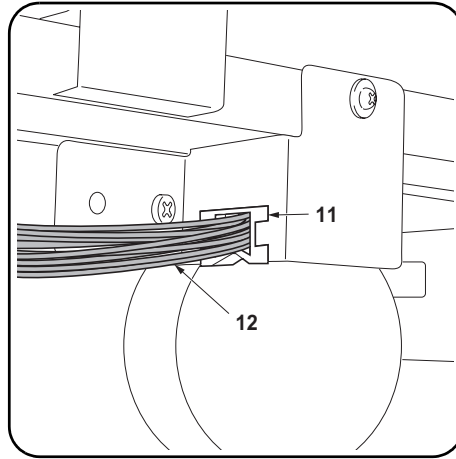

11. Pass the wires (12) through the clamp (11).
Be sure to pass the wires (12) through the clamp (11) because the wires (12) may touch the motor.

12. Refit the cover (7) using the screw (6) removed in step 7.

10. Fixer la plaque de raccord (C) à l'aide de deux vis.
A droite: Utiliser la vis (8) retirée auparavant à l'étape 8.
A gauche: Utiliser la vis M3 × 6 (D).

11. Faire passer les fils (12) par le collier (11).
Veiller à faire passer les fils (12) par le collier (11) car les fils (12) risqueraient d'entrer en contact avec le moteur.

12. Remettre le couvercle (7) en place à l'aide de la vis (6) retirée auparavant à l'étape 7.

10. Instale la placa de unión (C) utilizando dos tornillos.
Derecho: Utilice el tornillo (8) quitado en el paso 8.
Izquierdo: Utilice el tornillo M3 × 6 (D)

11. Pase los cables (12) por la ménsula (11).
Asegúrese de pasar los cables (12) por la ménsula (11) porque los cables (12) pueden tocar el motor.

12. Vuelva a colocar la tapa (7) utilizando el tornillo (6) quitado en el paso 7.

10. Die Verbindungsplatte (C) mit zwei Schrauben befestigen.
Rechts: Die in Schritt 8 entfernte Schraube (8) benutzen.
Links: Die M3 × 6 Schraube (D) benutzen.

11. Die Kabel (12) durch die Klemme (11) führen.
Die Kabel (12) müssen unbedingt durch die Klemme (11) geführt werden, weil sie sonst den Motor berühren können.

12. Bringen Sie die Abdeckung (7) wieder mit der in Schritt 7 entfernten Schraube (6) an.

10. Montare la piastra di giunzione (C) utilizzando due viti.
Destra: utilizzare la vite (8) rimossa nel passo 8.
Sinistra: utilizzare la vite M3 × 6 (D).

11. Fare passare i cavi (12) attraverso il morsetto (11).
Assicurarsi di fare passare i cavi (12) attraverso il morsetto (11) perché potrebbero toccare il motore.

12. Inserire il pannello posteriore (7) usando le viti (6) rimosse al punto 7.

10. 用2个螺丝固定连接金属件(C)。
右侧: 在步骤8上拆下的螺丝(8)。
左侧: 螺丝M3 × 6(D)。

11. 将电线(12)穿过夹钳(11)。
务必将电线(12)穿过夹钳(11), 以免电线(12)碰触马达。

12. 用步骤7拆除的1个螺丝(6)将盖板(7)装回原来的位置。

10. ビス2本で接続金具(C)を取り付ける。
右側: 手順8で外したビス(8)
左側: ビスM3 × 6(D)

11. クランプ(11)に電線(12)を通す。
電線(12)がモータに接触する恐れがあるので、必ずクランプ(11)に電線(12)を通すこと。

12. 手順7で外したビス(6)1本でカバー(7)を元通り取り付け。

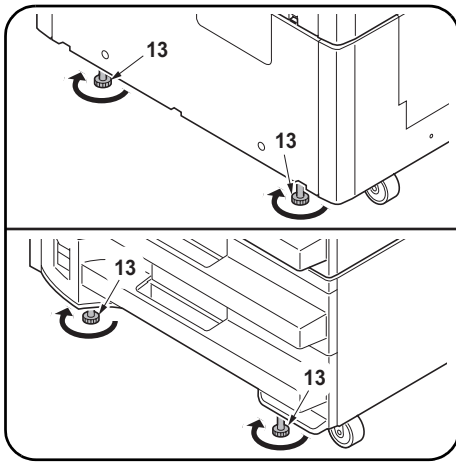

Adjusting the height

13. Turn four adjusters (13) until they reach the floor and then adjust them so that the machine becomes level.

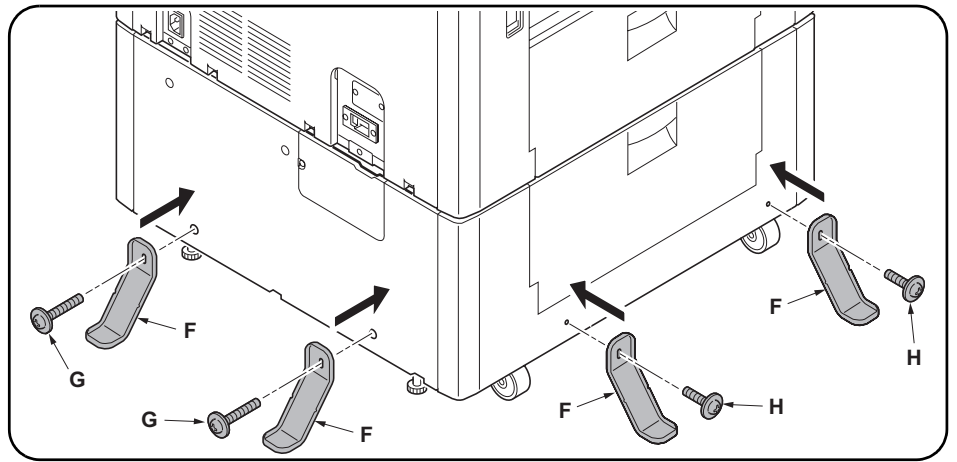

Attaching the stays (For 110V, 120 V, and 220-240 V specifications)

14. Attach two stays (F) at the rear side of the paper feeder using an M4 × 20 screw (G) for each. Also, attach two stays (F) at the left side using an M4 × 10 screw (H) for each.
Do not attach the stays (F) at the left side when installing the document finisher.

Réglage de la hauteur

13. Tourner les quatre pieds réglables (13) jusqu'à ce qu'ils atteignent le sol, puis les ajuster de manière que la machine soit bien horizontale.

Fixation des supports (pour spécifications 110 V, 120 V, et 220-240 V)

14. Fixer deux supports (F) sur le côté arrière du bureau papier à l'aide d'une vis M4 × 20 (G) pour chaque support.
Fixer aussi deux supports (F) sur le côté gauche à l'aide d'une vis M4 × 10 (H) pour chaque support.
Ne pas fixer les supports (F) sur le côté gauche lors de l'installation du retoucheur de document.

Ajuste de la altura

13. Gire los cuatro ajustadores (13) hasta que lleguen al piso y ajústelos hasta que la máquina quede horizontal.

Colocación de las bases (especificaciones de 110V, 120V y 220-240V)

14. Coloque las dos bases (F) en el lado trasero del alimentador de papel utilizando un tornillo M4 × 20 (G) para cada uno.
Además, coloque dos bases (F) en el lado izquierdo utilizando un tornillo M4 × 10 (H) para cada uno.
No instale las bases (F) en el lado izquierdo cuando instale el finalizador de documentos.

Einstellen der Höhe

13. Die vier Einstellfüße (13) drehen, bis sie den Boden erreichen, und dann so einstellen, dass die Maschine waagrecht steht.

Anbringen der Stützen (Für 110-V-, 120-V- und 220-240-V-Spezifikationen)

14. Die zwei Stützen (F) mit je einer M4 × 20 Schraube (G) auf der Rückseite des Papiereinzugs befestigen.
Außerdem zwei Stützen (F) mit je einer M4 × 10 Schraube (H) auf der linken Seite befestigen.
Bei Installation des Dokumentenfinishers die Stützen (F) nicht auf der linken Seite anbringen.

Regolazione dell'altezza

13. Ruotare i quattro piedini regolabili (13) sino a quando vengono a contatto con il pavimento e poi regolarli in modo da livellare la macchina.

Inserimento delle sospensioni (specifiche solo per 110 V, 120 V e 220-240 V)

14. Inserire le due sospensioni (F) nel retro dell'unità di alimentazione della carta utilizzando una vite M4 × 20 (G) per ciascuna.
Inserire, inoltre, due sospensioni (F) nel lato sinistro utilizzando una vite M4 × 10 (H) per ciascuna.
Non inserire le sospensioni (F) nel lato sinistro quando si installa la finitrice di documenti.

調整高度

13. 旋转4个角落的高度调节器(13)直至碰到地板,以调整整个机器的水平。

防倒金属件的安装(仅适用于110V、120V、220-240V)

14. 在供纸盒的后侧2处各用1个螺丝M4 × 20(G)安装防倒金属件(F)。
在供纸盒的左侧2处各用1个螺丝M4 × 10(H)安装防倒金属件(F)。
若安装装订器时,则不需要在供纸盒左侧安装防倒金属件(F)。

高さ調整

13. 4隅のアジャスター(13)を床に接触するまで回転し、機械全体を水平に調整する。

転倒防止金具の取り付け(110V・120V・220-240V仕様のみ)

14. ビスM4 × 20(G)各1本で転倒防止金具(F)をペーパーフィーダ後側2箇所に取り付ける。
ビスM4 × 10(H)各1本で転倒防止金具(F)をペーパーフィーダ左側2箇所に取り付ける。
ドキュメントフィニッシャを設置する場合は、ペーパーフィーダ左側に転倒防止金具(F)の取り付けはおこなわない。

Checking the center line

15. Connect the power plug of the machine to the wall outlet and turn the main power switch on.

16. Load paper in each cassette.

Make a proof copy to check the operation.

17. Select maintenance mode U402 and print the test pattern.

Vérification de la ligne médiane

15. Insérer la fiche d'alimentation de la machine dans la prise murale et mettre la machine sous tension.

16. Mettre du papier dans chaque tiroir.

Effectuer une copie d'essai pour vérifier le fonctionnement.

17. Sélectionner le mode maintenance U402 et imprimer la mire d'essai.

Verificación de la línea central

15. Conecte el enchufe eléctrico de la máquina en un tomacorriente de la pared y conecte el interruptor principal.

16. Coloque el papel en cada bandeja.

Haga una copia de prueba para verificar e funcionamiento.

17. Seleccione el modo de mantenimiento U402 e imprima el patrón de prueba.

Überprüfen der Mittellinie

15. Den Netzstecker der Maschine in die Steckdose stecken, und den Betriebsschalter einschalten.

16. Papier in jede Kassette einlegen.

Eine Probekopie anfertigen, um den Betrieb zu überprüfen.

17. Den Wartungsmodus U402 wählen und das Testmuster ausdrucken.

Controllare la linea centrale

15. Collegare la spina del cavo di alimentazione della macchina alla presa a muro della rete elettrica e accendere l'interruttore principale di alimentazione.

16. Caricare la carta in ciascun cassetto .

Eseguire una copia di prova per controllare il funzionamento.

17. Selezionare la modalità manutenzione U402 e stampare il modello di prova.

中心线的确认

15. 将机器主机上的电源插头插入插座中，打开主电源开关。

16. 将复印纸装入供纸盒。

进行测试复印，确认复印动作状态。

17. 选择维修模式 U402，打印测试图案。

センターラインの確認

15. 機械本体の電源プラグをコンセントに差し込み、主電源スイッチを ON にする。

16. 各カセットに用紙をセットする。

テストコピーをおこない、動作を確認する。

17. メンテナンスモード U402 を選び、テストパターンを出力する。

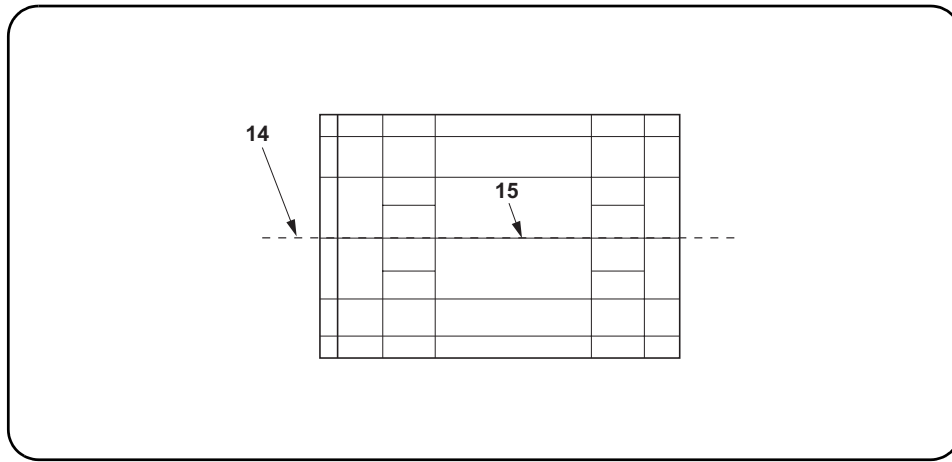

- 18.** Check the center line of paper (14) and the center line of test pattern (15).
If the gap of lines (14) and (15) exceeds the reference value, proceed to step 19.
Reference value: 2.0 mm or less

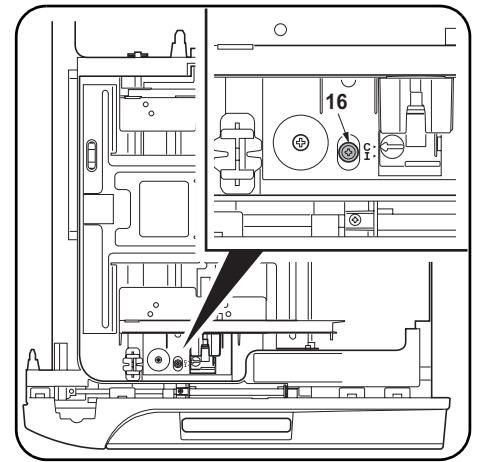

- Adjusting the center line**
19. Pull the cassette out and loosen the screw (16) of the adjusting plate.

- 18.** Vérifier la ligne médiane du papier (14) et la ligne médiane de la mire (15).
Si l'écart des lignes (14) et (15) est supérieur à la valeur de référence, passer à l'étape 19.
Valeur de référence: 2,0 mm ou moins

- Réglage de la ligne médiane**
19. Tirer le tiroir vers l'extérieur et desserrer la vis (16) de la plaque de réglage.

- 18.** Verifique la línea central del papel (14) y la línea central del patrón de prueba (15).
Si la separación entre las líneas (14) y (15) supera el valor de referencia, vaya al paso 19.
Valor de referencia: 2,0 mm o menos

- Ajuste de la línea central**
19. Abra la bandeja y afloje el tornillo (16) de la placa de ajuste.

- 18.** Die Mittellinie des Papiers (14) mit der Mittellinie des Testmusters (15) vergleichen.
Falls die Abweichung zwischen den Linien (14) und (15) den Bezugswert überschreitet, zu Schritt 19 übergehen.
Bezugswert: maximal 2,0 mm

- Einstellen der Mittellinie**
19. Die Kassette herausziehen, und die Schraube (16) der Einstellplatte lösen.

- 18.** Controllare la linea centrale della carta (14) e la linea centrale del modello di prova (15).
Se la distanza tra le linee (14) e (15) supera il valore di riferimento, continuare con il passo 19.
Valore di riferimento: fino a 2,0 mm

- Regolazione della linea centrale**
19. Estrarre il cassetto e allentare la vite (16) della piastra di regolazione.

- 18.** 确认复印纸的中心线 (14) 与测试图案的中心线 (15)。
超过偏移标准值时, 操作步骤 19 以后的项目。
< 标准值 > 2.0mm 以下

- 中心线的调整**
19. 拉出供纸盒, 松开调整板的 1 个螺丝 (16)。

- 18.** 用紙のセンターライン (14) とテストパターンのセンターライン (15) を確認する。
ずれが基準値外の場合は、手順 19 以降をおこなう。
< 基準値 > 2.0mm 以下

- センターライン調整**
19. カセットを引き出し、調整板のビス (16) 1 本を緩める。

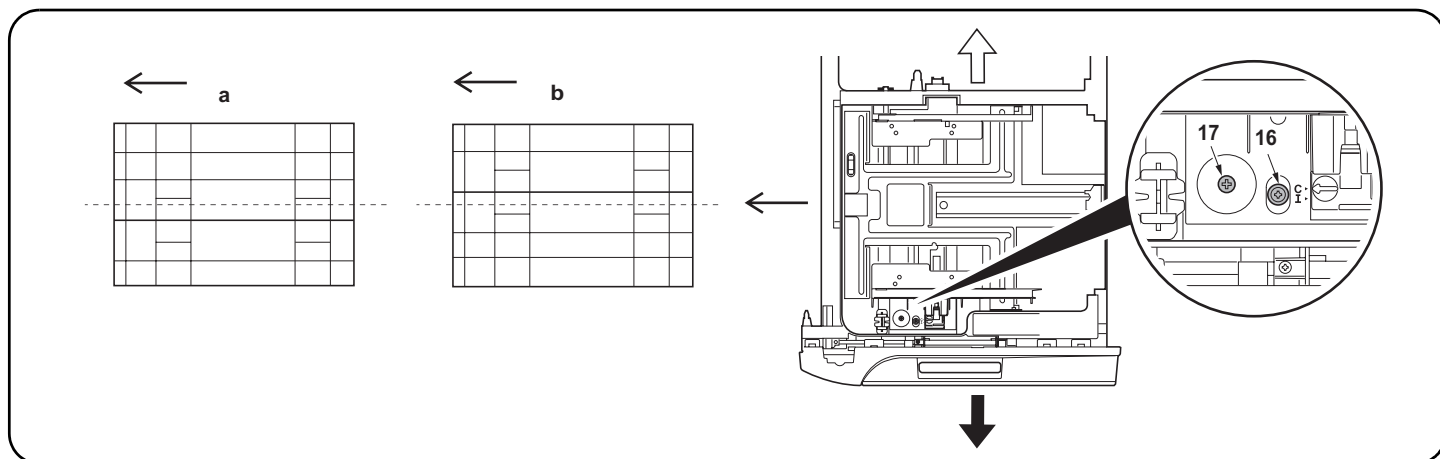

20. For a test pattern example (a):

Turn the adjusting screw (17) clockwise (the adjuster will move in the direction of arrow (➡)), and tighten 1 screw (16).

For a test pattern example (b):

Turn the adjusting screw (17) counterclockwise (the adjuster will move in the direction of arrow (⬅)) and tighten 1 screw (16).

21. Gently close the cassette.

22. Print a test pattern again.

**23. Repeat steps 19 to 22 until the gap of the center lines of paper and the test pattern shows the following reference value.
Reference value: 2.0 mm or less**

20. Pour un exemple de mire (a):

Tournez la vis de réglage (17) dans le sens des aiguilles d'une montre (le dispositif de réglage se déplace dans la direction de la flèche (➡)) et resserrez 1 vis (16).

Pour un exemple de mire (b):

Tournez la vis de réglage (17) dans le sens inverse des aiguilles d'une montre (le dispositif de réglage se déplace dans la direction de la flèche (⬅)) et resserrez 1 vis (16).

21. Refermer progressivement le tiroir.

22. Imprimer à nouveau une mire.

**23. Répéter les étapes 19 à 22 jusqu'à ce que l'écart entre les lignes médianes du papier et la mire corresponde bien à la valeur de référence suivante.
Valeur de référence: 2,0 mm ou moins**

20. Para un ejemplo de patrón de prueba (a):

Gire el tornillo de ajuste (17) en sentido horario (el regulador se moverá en la dirección de la flecha (➡)) y apriete 1 tornillo (16).

Para un ejemplo de patrón de prueba (b):

Gire el tornillo de ajuste (17) en sentido antihorario (el regulador se moverá en la dirección de la flecha (⬅)) y apriete 1 tornillo (16).

21. Cierre suavemente la bandeja.

22. Vuelva a imprimir un patrón de prueba.

**23. Repita los pasos 19 a 22 hasta que la separación entre las líneas del papel y del patrón de prueba muestra el siguiente valor de referencia.
Valor de referencia: 2,0 mm o menos**

20. Für das Testmuster-Beispiel (a):

Drehen Sie die Einstellschraube (17) im Uhrzeigersinn (der Anpasser bewegt sich in der Pfeilrichtung(➡)), und ziehen Sie 1 Schraube (16) fest.

Für das Testmuster-Beispiel (b):

Drehen Sie die Einstellschraube (17) entgegen dem Uhrzeigersinn (der Anpasser bewegt sich in der Pfeilrichtung(⬅)), und ziehen Sie 1 Schraube (16) fest.

21. Die Kassette sanft schließen.

22. Das Testmuster erneut drucken.

**23. Die Schritte 19 bis 22 wiederholen, bis die Abweichung zwischen den Mittellinien des Papiers und des Testmusters innerhalb des folgenden Bezugswerts liegt.
Bezugswert: maximal 2,0 mm**

20. Per un esempio di un modello di prova (a):

Girare la vite di regolazione (17) in senso orario (il regolatore si sposterà nella direzione della freccia (➡)), e serrare 1 vite (16).

Per un esempio di un modello di prova (b):

Girare la vite di regolazione (17) in senso antiorario (il regolatore si sposterà nella direzione della freccia (⬅)), e serrare 1 vite (16).

21. Chiudere delicatamente il cassetto.

22. Stampare nuovamente un modello di prova.

**23. Ripetere i passi da 19 a 22 fino a quando la distanza tra le linee centrali della carta e del modello di prova indica il seguente valore di riferimento.
Valore di riferimento: fino 2,0 mm**

20. 测试图案 (a) 时

顺时针转动调节螺丝 (17) (调节器沿箭头 (➡) 所示方向移动), 然后拧紧 1 个螺丝 (16)。

测试图案 (b) 时

逆时针转动调节螺丝 (17) (调节器沿箭头 (⬅) 所示方向移动), 然后拧紧 1 个螺丝 (16)。

21. 轻轻地推入供纸盒。

22. 再次进行测试图案的输出。

**23. 重复操作步骤 19 ~ 22, 直到复印纸的中心线与测试图案的中心线为标准值内为止。
<标准值> 2.0mm 以下**

20. テストパターン (a) の場合

調整ネジ (17) を右に回し(調整板が矢印 (➡) 方向に移動)、ビス (16) 1 本を締め付ける。

テストパターン (b) の場合

調整ネジ (17) を左に回し(調整板が矢印 (⬅) 方向に移動)、ビス (16) 1 本を締め付ける。

21. カセットを静かに押し込む。

22. テストパターンを再度出力する。

**23. 用紙のセンターラインとテストパターンのセンターラインが基準値内になるまで、手順 19 ~ 22 を繰り返す。
<基準値> 2.0mm 以下**

INSTALLATION GUIDE FOR DOCUMENT FINISHER

Output Connector for Interconnecting Cable is non-LPS.
Output: 24 V dc (426 VA max.)
Please use the item below Interconnecting Cables.
P/N: 305H180180

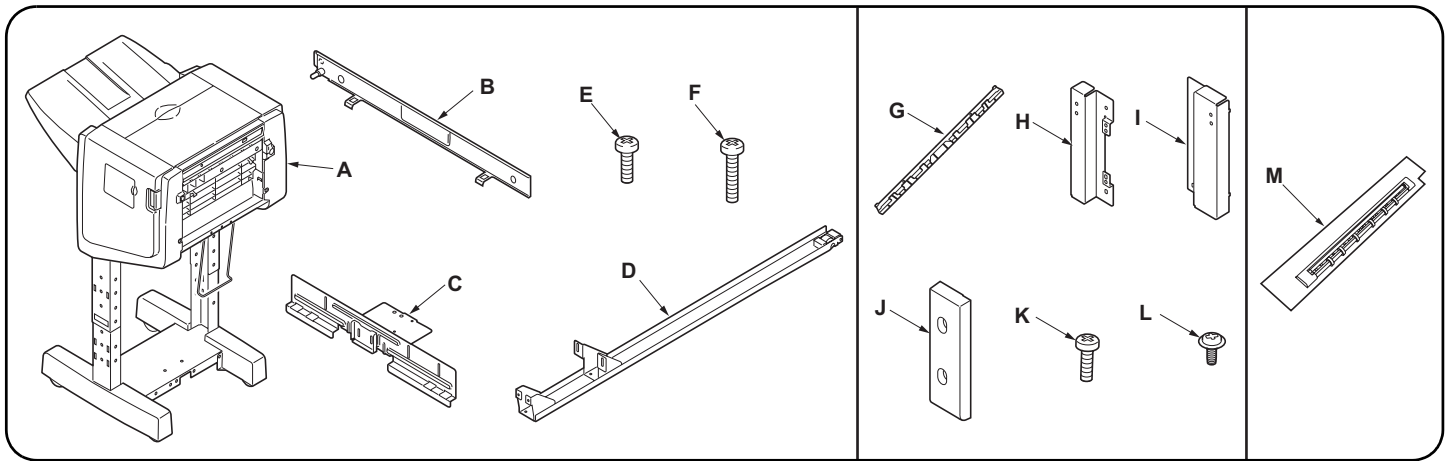

English

Supplied parts

A Document finisher	1
B Latch catch	1
C Rail retainer	1
D Guide rail	1
E Binding screw M4 x 6	4

F Binding screw M4 x 14	2
G Guide plate	1
H Fixing plate F	1
I Fixing plate R	1
J Cover AT	1
K S Tite screw M4 x 10	9
L Shoulder screw	1
M Curl eliminator	1

When installing the document finisher to a full-color MFP, use parts (G), (H), (I), (J), (K) and (L) supplied with the job separator.

For monochrome machines, part (M) is needed separately.
Be sure to remove any tape and/or cushioning material from supplied parts.

Français

Pièces fournies

A Retoucheur de document	1
B Pontet du loquet	1
C Élément de rétention du rail	1
D Glissière	1
E Vis de raccordement M4 x 6	4

F Vis de raccordement M4 x 14	2
G Plaque guide	1
H Plaque de fixation avant	1
I Plaque de fixation arrière	1
J Couvercle AT	1
K Vis S Tite M4 x 10	9
L Vis d'épaule	1
M Élément d'élimination des boucles	1

Lors de l'installation du retoucheur de documents sur une MFP polychrome, les pièces (G), (H), (I), (J), (K) et (L) avec le séparateur de travaux sont requises.

Sur les machines monochromes, il faut utiliser la pièce (M) séparément.
Veillez à retirer les morceaux de bande adhésive et/ou les matériaux de rembourrage des pièces fournies.

Español

Partes suministradas

A Finalizador de documentos	1
B Cerrojo	1
C Retén del carril	1
D Carril guía	1
E Tornillo de sujeción M4 x 6	4

F Tornillo de sujeción M4 x 14	2
G Placa guía	1
H Placa de fijación F	1
I Placa de fijación R	1
J Cubierta AT	1
K Tornillo S Tite M4 x 10	9
L Tornillo de hombro	1
M Eliminador de enrollado	1

Cuando instale el finalizador de documentos en una MFP a todo color serán necesarias las partes (G), (H), (I), (J), (K), y (L) suministradas con el separador de tareas.

Para las máquinas monocromáticas, es necesario por separado la pieza (M).
Asegúrese de despegar todas las cintas y/o material amortiguador de las partes suministradas.

Deutsch

Gelieferte Teile

A Dokument Finishers	1
B Riegelschloßbausatz	1
C Schienenhalterungseinheit	1
D Führungsschieneneneinheit	1
E Verbundschraube M4 x 6	4

F Verbundschraube M4 x 14	2
G Führungsplatte	1
H Fixierplatte F	1
I Fixierplatte R	1
J Abdeckung AT	1
K S-Tite-Schraube M4 x 10	9
L Bundschraube	1
M Glättungseinrichtung	1

Wenn der Dokument-Finisher auf einem Farbmultifunktionsgerät angebracht wird, sind die Teile (G), (H), (I), (J), (K) und (L), die mit dem Jobtrenner gelieferten erforderlich.

Für Monochrommaschinen wird Teil (M) getrennt benötigt.
Entfernen Sie Klebeband und/oder Dämpfungsmaterial vollständig von den mitgelieferten Teilen.

Italiano

Parti fornite

A Finitrice di documenti	1
B Dispositivo di arresto	1
C Fermo della guida	1
D Guida della rotaia	1
E Vite di serraggio M4 x 6	4

F Vite di serraggio M4 x 14	2
G Piastra della guida	1
H Piastra di fissaggio F	1
I Piastra di fissaggio R	1
J Coperchio AT	1
K Vite S Tite M4 x 10	9
L Vite a colletto	1
M Eliminatore di pieghe	1

Per l'installazione della finitrice di documenti su un MFP a colori, sono necessarie le parti (G), (H), (I), (J), (K) e (L) fornite in dotazione con il separatore dei lavori.

Per le macchine in bianco e nero, separatamente è necessaria la parte (M).
Accertarsi di rimuovere tutti i nastri adesivi e/o il materiale di imbottitura dalle parti fornite.

简体中文

附属品

A 装订器	1
B 挂钩承支架	1
C 轨道座	1
D 导向轨道	1
E M4 x 6 固结螺钉	4

F M4 x 14 固结螺钉	2
G 导向板	1
H 固定板 F	1
I 固定板 R	1
J 盖板 AT	1
K 紧固螺钉 M4 x 10S	9
L 阶梯螺钉	1
M 防卷曲部件	1

全彩色 MFP 上安装装订器时, 请使用作业分离器上附属的部件 (G)、(H)、(I)、(J)、(K) 和 (L)。

黑白机时, 不需要安装 (M) 部件。
如果同部品上带有固定胶带, 缓冲材料时务必取下。

日本語

同梱品

A ドキュメントフィニッシャ	1
B ラッチ受け板	1
C レール取付板	1
D ガイドレール	1
E ビス M4 x 6 バインド	4

F ビス M4 x 14 バインド	2
G ガイド板	1
H 固定板 F	1
I 固定板 R	1
J カバー AT	1
K ビス M4 x 10 S タイト	9
L 段付きビス	1
M デカーラー	1

フルカラー MFP 機にドキュメントフィニッシャを設置する場合、ジョブセパレータに付属する (G)、(H)、(I)、(J)、(K)、(L) が必要となる。

モノクロ機では、(M) が別途必要です。
同梱品に固定テープ、緩衝材が付いている場合は必ず取り外すこと。

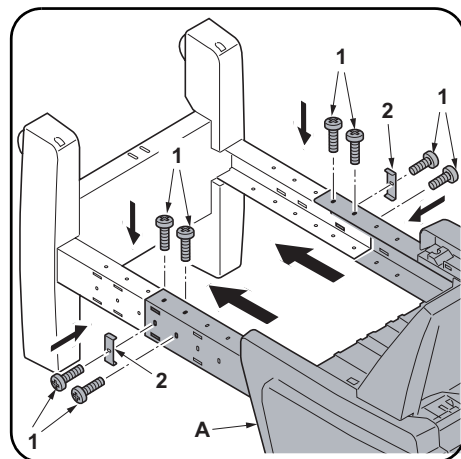
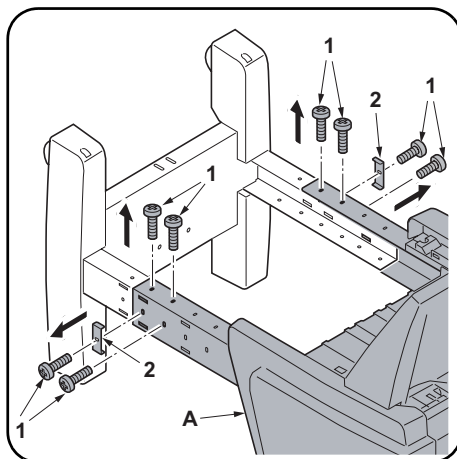

Procedure

Before installing the document finisher, first attach the job separator.
Be sure to turn the MFP main power switch off and disconnect the MFP power plug from the wall outlet before starting to install the document finisher.

[Steps 1 to 5 below are only for full-color machines.]

1. Place the document finisher (A) sideways, remove the eight screws (1), and remove the two pieces of fittings (2).

2. To align the document finisher with the paper outlet of the MFP, slide the legs of the document finisher (A) to the uppermost positions indicated in the illustration, attach the two pieces of fittings (2) that have been removed in step 1, and secure them using the eight screws (1).

Procédure

Avant d'installer le retoucheur de document, fixer d'abord le séparateur de travaux.
Veiller à bien mettre l'interrupteur principal du MFP hors tension et à débrancher la fiche d'alimentation du MFP de la prise murale avant de commencer l'installation du retoucheur de document.

[Les étapes 1 à 5 ci-dessous concernent les machines entièrement en couleurs seulement.]

1. Placer le retoucheur de documents (A) sur le côté, retirer les huit vis (1), et retirer les deux pièces de fixation (2).

2. Pour aligner le retoucheur de document sur la sortie de papier du MFP, faire glisser les pieds du retoucheur de document (A) jusqu'aux positions les plus hautes indiquées sur l'illustration, fixer les deux pièces de fixation (2) qui avaient été retirées auparavant à l'étape 1, et les fixer à l'aide des huit vis (1).

Procedimiento

Antes de instalar el finalizador de documentos, coloque primero el separador de trabajos.
Asegúrese de apagar el interruptor principal del MFP y de desconectar la clavija de alimentación del MFP de la toma de corriente de la pared, antes de empezar a instalar el finalizador de documentos.

[Los pasos 1 a 5 a continuación son solo para máquinas a todo color.]

1. Apoye el finalizador de documentos (A) sobre un lado, saque los ocho tornillos (1) y saque dos piezas de herrajes (2).

2. Para alinear el finalizador de documentos con la salida de papel del MFP, deslice las patas del finalizador de documentos (A) a las posiciones superiores indicadas en la figura, instale las dos piezas de herrajes (2) desmontadas en el paso 1 y asegúrelos con los ocho tornillos (1).

Verfahren

Vor dem Installieren des Dokument Finishers ist zuerst der Jobtrenner anzubringen.
Schalten Sie den MFP-Hauptschalter aus, und ziehen Sie den MFP-Netzstecker von der Netzsteckdose ab, bevor Sie mit der Installation des Dokument Finishers beginnen.

[Die folgenden Schritte 1 bis 5 gelten nur für Vollfarbmaschinen.]

1. Den Dokument Finisher (A) auf die Seite legen, die acht Schrauben (1) entfernen, und die zwei Befestigungsteile (2) abnehmen.

2. Um den Dokument Finisher auf den Papierausslass des MFP auszurichten, die Beine des Dokument Finishers (A) auf die in der Abbildung gezeigte oberste Position schieben, dann die zwei in Schritt 1 entfernten Befestigungsteile (2) anbringen und mit den acht Schrauben (1) befestigen.

Procedura

Prima di installare la finitrice di documenti, installare prima il separatore dei lavori.
Prima di dare inizio alla procedura di installazione della finitrice di documenti, non mancare di spegnere l'MFP usando l'interruttore principale di alimentazione e disinserire la spina dell'MFP dalla presa a muro della rete elettrica.

[I seguenti passi da 1 a 5 sono solo per le macchine a colori.]

1. Collocare la finitrice di documenti (A) lateralmente, rimuovere le otto viti (1) e rimuovere i due pezzi di raccordo (2).

2. Per allineare la finitrice di documenti con l'uscita della carta dell'MFP, fare scivolare i piedini della finitrice di documenti (A) sulle posizioni più in alto indicate nel disegno, montare i due pezzi di raccordo (2) che sono stati rimossi nel passo 1 e fissarli utilizzando le otto viti (1).

安裝步驟

安裝裝訂器前，首先安裝作業分离器。
當安裝裝訂器時，必須事先將 MFP 主機的總電源关掉並將 MFP 主機的電源插頭從插座上拔掉。

[步驟 1~5 仅限于全彩色机]

1. 將裝訂器 (A) 橫向放置，卸下 8 個螺釘 (1)，然後，取下 2 個固定件 (2)。

2. 為了對准主機排紙口，先將裝訂器 (A) 的機腳滑動到最上面的位置 (如圖所示的位置)，然後，安裝在步驟 1 取下的 2 個固定件 (2)，并用 8 個螺釘 (1) 加以固定。

取付手順

ドキュメントフィニッシャを取り付ける際には、先にジョブセパレータを装着すること。
ドキュメントフィニッシャを取り付ける際は、必ず MFP 本体の主電源スイッチを OFF にし、電源プラグを外して作業をおこなうこと。

[手順 1~5 はフルカラー機のみ]

1. ドキュメントフィニッシャ (A) を横向きにおき、ビス (1) 8 本を外し、固定金具 (2) 2 個を取り外す。

2. 本体用紙排出口に合わせる為、ドキュメントフィニッシャ (A) の脚を最上の位置 (図の位置) までスライドさせ、手順 1 で取り外した固定金具 (2) 2 個を取り付け、ビス (1) 8 本で固定する。

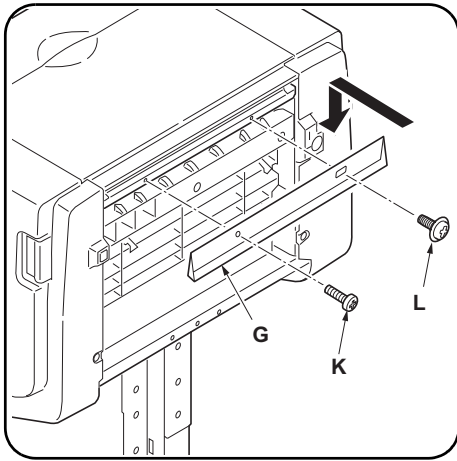

3. Secure the guide plate (G) using the shoulder screw (L) and an S Tite screw M4 x 10 (K).

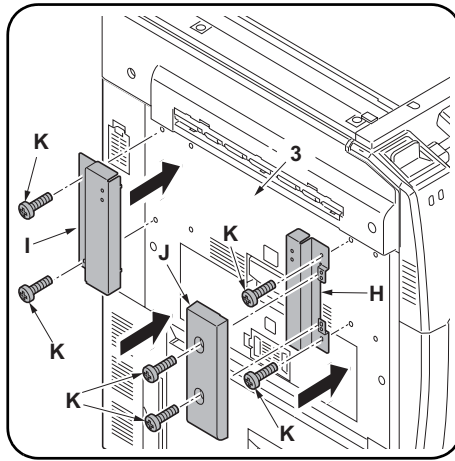

4. Fit the fixing plate F (H) and the fixing plate R (I) to the left cover (3) using two S Tite screws M4 x 10 (K) for each and fit the cover AT (J) to the fixing plate F (H) using two S Tite screws M4 x 10 (K).

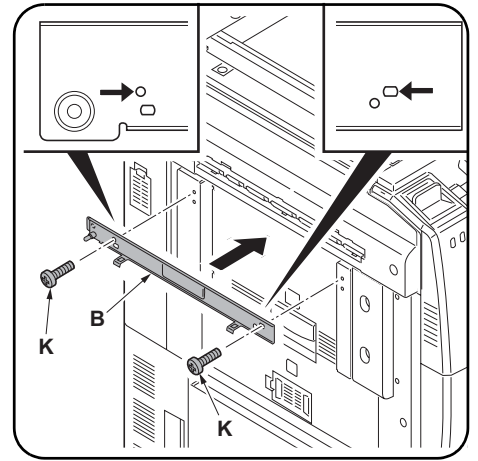

5. Fit the latch catch (B) to the fixing plate F (H) and the fixing plate R (I) using two S Tite screws M4 x 10 (K). Attach with the upper screw holes underneath fixing plates F (H) and R (I).
When using a full-color machine: Proceed to step 7 on page 5

3. Fixez la plaque guide (G) à l'aide de la vis d'épaule (L) et d'une vis S Tite M4 x 10 (K).

4. Fixer la plaque de fixation avant (H) et la plaque de fixation arrière (I) sur le couvercle de gauche (3) à l'aide de deux vis S Tite M4 x 10 (K) chaque et fixer le couvercle AT (J) sur la plaque de fixation avant (H) à l'aide de deux vis S Tite M4 x 10 (K).

5. Fixer le pontet du loquet (B) sur la plaque de fixation avant (H) et sur la plaque de fixation arrière (I) à l'aide de deux vis S Tite M4 x 10 (K). Fixer à partir des trous de vis supérieurs se trouvant sous les plaques de fixation avant (H) et arrière (I).
Lors de l'utilisation de la machine entièrement en couleurs: passer à l'étape 7 de la page 5

3. Asegure la placa guía (G) utilizando el tornillo de hombro (L) y un tornillo S Tite M4 x 10 (K).

4. Encaje la placa de fijación F (H) y la placa de fijación R (I) en la cubierta izquierda (3) utilizando dos tornillos S Tite M4 x 10 (K) para cada una y encaje la cubierta AT (J) en la placa de fijación F (H) utilizando dos tornillos S Tite M4 x 10 (K).

5. Encaje el cerrojo (B) en la placa de fijación F (H) y la placa de fijación R (I) utilizando los dos tornillos S Tite M4 x 10 (K). Fije con los orificios para tornillos superiores debajo de las placas de fijación F (H) y R (I).
Cuando utilice una máquina a todo color: Vaya al paso 7 de la página 5

3. Die Führungsplatte (G) mit der Bundschraube (L) und einer S-Tite-Schraube M4 x 10 (K) befestigen.

4. Die Fixierplatte F (H) und die Fixierplatte R (I) mit je zwei S-Tite-Schrauben M4 x 10 (K) an der linken Abdeckung (3) anbringen, und die Abdeckung AT (J) mit zwei S-Tite-Schrauben M4 x 10 (K) an der Fixierplatte F (H) anbringen.

5. Die Riegelschloßbausatz (B) mit zwei S-Tite-Schrauben M4 x 10 (K) an der Fixierplatte F (H) und die Fixierplatte R (I) anbringen. Mit den oberen Schraublöchern unter den Fixierplatten F (H) und R (I) anbringen.
Bei Verwendung eines Vollfarbkopierers: Gehen Sie zum Schritt 7 auf Seite 5 weiter

3. Fissare la piastra della guida (G) utilizzando la vite a colletto (L) e la vite S Tite M4 x 10 (K).

4. Montare la piastra di fissaggio F (H) e la piastra di fissaggio R (I) sul coperchio sinistro (3) usando due vite S Tite M4 x 10 (K) per ciascuna di esse e montare il coperchio AT (J) sulla piastra di fissaggio F (H) usando due vite S Tite M4 x 10 (K).

5. Montare il dispositivo di arresto (B) sulla piastra di fissaggio F (H) e sulla piastra di fissaggio R (I) usando due vite S Tite M4 x 10 (K). Collegare con i fori per le viti superiori, sotto le piastre di fissaggio F (H) e R (I).
IN caso si utilizzi un macchinario a colori: Procedere con il punto 7 a pagina 5

3. 在用阶梯螺钉 (L) 和紧固螺钉 M4 x 10S (K) 各 1 个固定导板 (G)。

4. 将固定板 F (H) 和固定板 R (I) 分别用 2 个紧固螺丝 M4 x 10S (K) 固定在左盖板 (3) 上, 将盖板 AT (J) 用 2 个紧固螺丝 M4 x 10S (K) 固定在固定板 F (H) 上。

5. 挂钩承支架 (B) 用 2 个紧固螺丝 M4 x 10S (K) 固定在固定板 F (H) 和固定板 R (I) 上。把固定板 F (H) 和 R (I) 固定在上侧的螺丝孔处。
使用全彩色机时: 进行第 5 页上的第 7 步

3. ガイド板 (G) を段付きビス (L) とビス M4 x 10S タイプ (K) 各 1 本で固定する。

4. 固定板 F (H) と固定板 R (I) を左カバー (3) にビス M4 x 10S タイプ (K) 各 2 本で固定し、カバー AT (J) をビス M4 x 10S タイプ (K) 2 本で固定板 F (H) に固定する。

5. ラッチ受け板 (B) をビス M4 x 10S タイプ (K) 2 本で固定板 F (H) と固定板 R (I) に固定する。固定板 F (H) と固定板 R (I) の上側のビス穴で固定すること。
フルカラー機の場合: 5 ページ手順 7 へ進む。

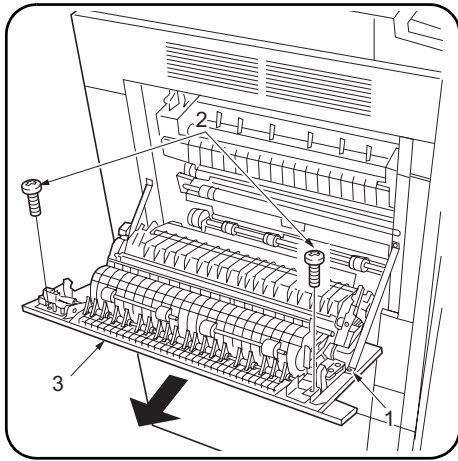

[Steps 1 to 6 below are only for monochrome machines.]

1. Open the eject cover (1) of the MFP or the printer.
2. Remove the two screws (2) securing the feedshift guide assembly (3) and then the assembly.

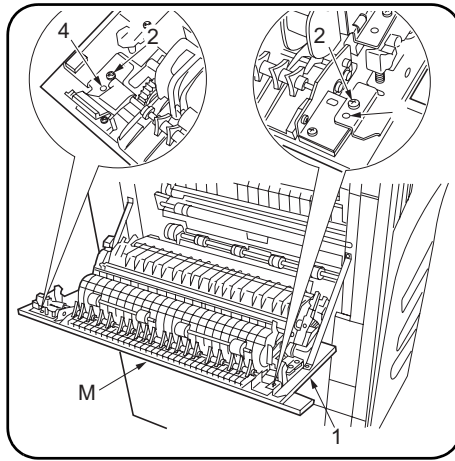

3. Fit the curl eliminator (M) to the eject cover (1) such that the projections (4) on the cover fit into the two ends of the curl eliminator (M).
4. Secure the curl eliminator (M) using the two screws (2) removed in step 2.

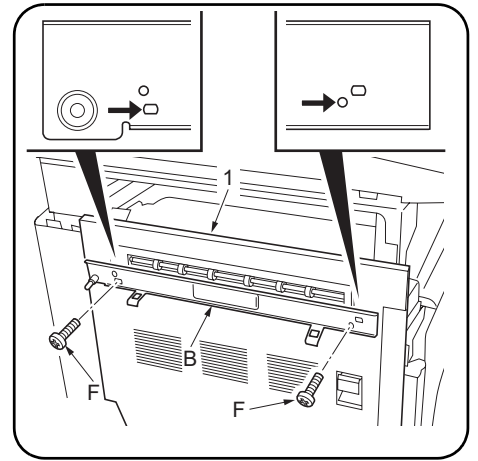

5. Close the eject cover (1).
6. Fit the latch catch (B) to the eject cover (1) using two M4 x 10 binding screws (F).

[Les étapes 1 à 6 ci-dessous concernent les machines monochromes seulement.]

1. Ouvrir le couvercle d'éjection (1) du MFP ou imprimante.
2. Retirer les deux vis (2) fixant l'assemblage de la glissière d'alimentation (3) puis retirer l'assemblage.

3. Fixer l'élément d'élimination des boucles (M) au couvercle d'éjection (1) de telle façon que les projections (4) du couvercle s'insèrent dans les deux extrémités de cet élément (M).
4. Fixer l'élément d'élimination des boucles (M) à l'aide des deux vis (2) retirées à l'étape 2.

5. Fermer le couvercle d'éjection (1).
6. Fixer le pontet du loquet (B) au couvercle d'éjection (1) à l'aide de deux vis de raccordement M4 x 10 (F).

[Los pasos 1 a 6 a continuación son sólo para máquinas monocromáticas.]

1. Abra la cubierta de expulsión (1) del MFP o impresora.
2. Quite los dos tornillos (2) que aseguran el ensamble guía de la unidad de cambio de alimentación de papel (3) y luego el ensamble.

3. Coloque el eliminador de enrollamiento (M) en la cubierta de expulsión (1) de modo que las proyecciones (4) de la cubierta encajen en los dos extremos del eliminador de enrollamiento (M).
4. Asegure el eliminador de enrollamiento (M) usando los dos tornillos (2) que quitó en el paso 2.

5. Cierre la cubierta de expulsión (1).
6. Coloque el cerrojo (B) en la cubierta de expulsión (1) usando dos tornillos de sujeción M4 x 10 (F).

[Die folgenden Schritte 1 bis 6 gelten nur für Monochrommaschinen.]

1. Öffnen Sie die Auswurfabdeckung (1) des MFP oder Drucker.
2. Entfernen Sie die zwei Schrauben (2), die den Zuführungswechsel-Bausatz (3) befestigen und dann den Bausatz.

3. Bringen Sie den Wellenverhinderer (M) so an die Auswurfabdeckung (1) an, daß die Vorsprünge (4) auf der Abdeckung in die zwei Enden des Wellenverhinderers (M) passen.
4. Befestigen Sie den Wellenverhinderer (M) mittels der in Schritt 2 entfernten zwei Schrauben (2).

5. Schliessen Sie die Auswurfabdeckung (1).
6. Bringen Sie den Riegelschloßbausatz (B) mittels der zwei M4 x 10 Verbundschrauben (F) an die Auswurfabdeckung (1) an.

[I seguenti passi da 1 a 6 sono solo per le macchine in bianco e nero.]

1. Aprire la copertura dell'uscita carta (1) dell'MFP o stampatore.
2. Rimuovere le due viti (2) che fissano il gruppo di guida di cambio alimentazione (3) e quindi il gruppo.

3. Inserire l'eliminatore degli accartocciamenti (M) nella copertura dell'uscita carta (1) in modo tale che le proiezioni (4) sulla copertura siano inserite nelle due estremità dell'eliminatore degli accartocciamenti (M).
4. Fissare l'eliminatore degli accartocciamenti (M) utilizzando le due viti (2) rimosse al punto 2.

5. Chiudere la copertura dell'uscita carta (1).
6. Inserire il dispositivo di arresto (B) nella copertura dell'uscita carta (1) utilizzando due viti di serraggio M4 x 10 (F).

[步骤 1 ~ 6 仅限于黑白机]

1. 将 MFP 或打印机的出纸盖板 (1) 打开。
2. 将两个小螺钉 (2) 摘下, 并将分支导向组件 (3) 卸下。

3. 将带凸肩压板的凸部 (4) 嵌入防卷曲部件 (M) 两端后, 将防卷曲部件 (M) 安装于出纸盖板 (1) 上。
4. 用依步骤 2 摘下的两个小螺钉 (2) 来固定防卷曲部件 (M)。

5. 将出纸盖板 (1) 关上。
6. 用两个 M4 x 10 固结螺钉 (F) 将挂钩支架 (B) 安装于出纸盖板 (1) 上。

[手順 1 ~ 6 はモノクロ機のみ]

1. MFP 本体またはプリンタ本体の排出カバー (1) を開く。
2. ビス (2) 2 本を外し、分岐ガイド組立 (3) を取り外す。

3. デカーラー (M) の両端に半押し (4) がはまる位置で、デカーラー (M) を排出カバー (1) に取り付ける。
4. 手順 2 で外したビス (2) 2 本でデカーラー (M) を固定する。

5. 排出カバー (1) を閉じる。
6. ラッチ受け板 (B) をビス M4 x 10 バインド (F) 2 本で排出カバー (1) に取り付ける。

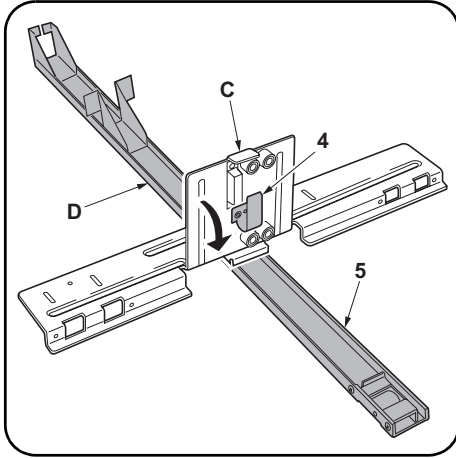

7. Tip the rail retainer (C) over in the direction of the arrow so that the retainer fits into the groove in the guide rail (D). Ensure that the plate spring (4) fits into the groove and that the edge (5) of the guide rail (D) fits between the rollers behind the rail retainer (C).

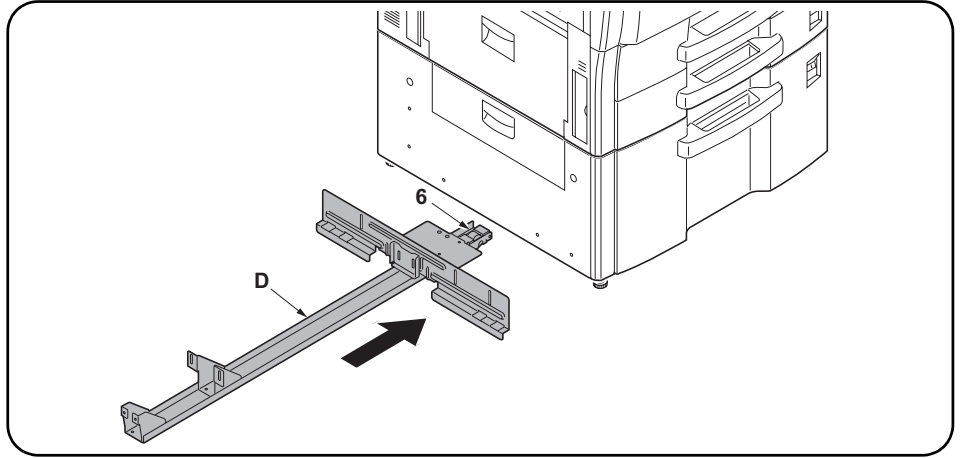

8. Orient the guide rail (D) such that its pulley (6) is positioned toward the MFP.

7. Retourner l'élément de rétention du rail (C) dans la direction de la flèche de sorte que l'élément de rétention s'insère dans la rainure de la glissière (D). S'assurer que le ressort de plaque (4) s'insère dans la rainure et que le bord (5) de la glissière (D) s'insère entre les rouleaux se trouvant derrière l'élément de rétention du rail (C).

8. Orienter la glissière (D) de manière que sa poulie (6) soit orientée vers le MFP.

7. Incline el retén del carril (C) en la dirección de la flecha de forma tal que el retén encaje en la acanaladura del carril guía (D). Asegúrese de que el resorte de la placa (4) encaje en la acanaladura y de que el borde (5) del carril guía (D) encaje entre los rodillos detrás del retén del carril (C).

8. Oriente el carril guía (D) de modo que su polea (6) se encuentre ubicada hacia el MFP.

7. Die Schienenhalterungseinheit (C) so weit in Pfeilrichtung neigen, dass die Halterung in die Rille der Führungsschieneneneinheit (D) greift. Darauf achten, dass die Tellerfeder (4) in die Rille passt, und dass die Kante (5) der Führungsschieneneneinheit (D) zwischen den Rollen auf der Rückseite der Schienenhalterungseinheit (C) sitzt.

8. Richten Sie die Führungsschiene (D) so aus, daß die Riemenscheibe (6) zum MFP ausgerichtet ist.

7. Capovolgere il fermo della guida (C) nella direzione della freccia, in modo che il fermo si inserisca nella scanalatura della guida della rotaia (D). Assicurarsi che la molla della piastra (4) si inserisca nella scanalatura, e che il bordo (5) della guida della rotaia (D) si inserisca tra i rulli dietro il fermo della guida (C).

8. Orientare la guida della rotaia (D) in modo da posizionare la puleggia (6) in direzione dell'MFP.

7. 将轨道座 (C) 沿箭头所示方向翻倒, 使轨道座嵌入导向轨道 (D) 的凹槽中。请确保板簧 (4) 嵌入凹槽中, 并且导向轨道 (D) 的边缘 (5) 嵌入轨道座 (C) 背面的滚轮和滚轮中间。

8. 使导向轨道 (D) 的滚轮部 (6) 朝向 MFP 主机。

7. レール取付板 (C) を矢印方向に倒し、レール取付板 (C) をガイドレール (D) の溝に合わせてはめ込む。板バネ部 (4) が溝の中に入り、レール取付板 (C) 裏側のコロとコロの間にガイドレール (D) の端 (5) が入るようにする。

8. ガイドレール (D) のコロ部 (6) を MFP 本体側に向ける。

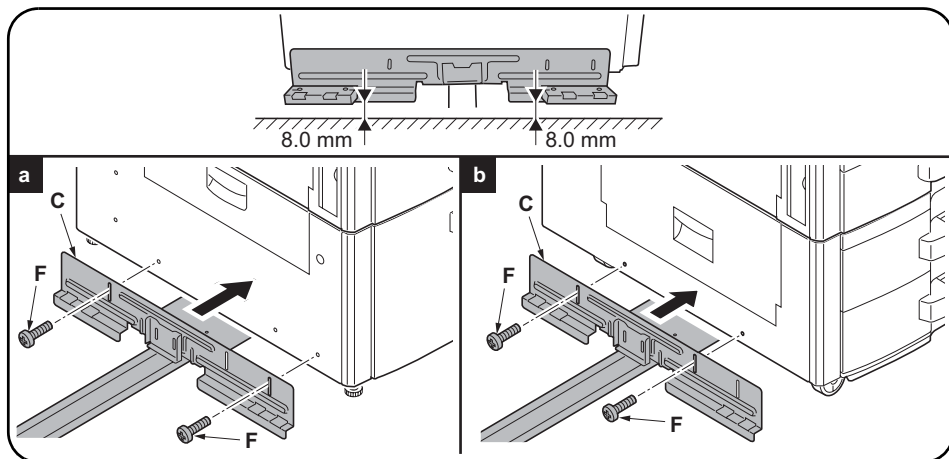

9. Secure the rail retainer (C) to the MFP using two M4 × 10 binding screws (F) such that the front and the rear gaps between the floor and the rail retainer (C) are approximately 8.0 mm.

- a: When the paper feeder of 3000 sheets is used
b: When the paper feeder of 500 sheets x 2 is used

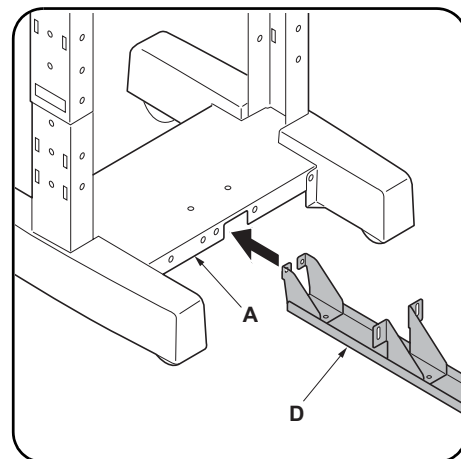

10. Insert the guide rail (D) into the bottom of the document finisher (A).

9. Fixer l'élément de rétention du rail (C) au MFP à l'aide de deux vis de raccordement M4 × 10 (F) de manière que les écarts avant et arrière entre le sol et l'élément de rétention du rail (C) soient d'environ 8.0 mm.

- a: Lors de l'utilisation de l'alimenteur de papier de 3000 feuilles
b: Lors de l'utilisation de l'alimenteur de papier de 500 feuilles x 2

10. Insérer la glissière (D) en bas du retoucheur de document (A).

9. Asegure el retén del carril (C) a el MFP usando dos tornillos de sujeción M4 × 10 (F) de modo que los espacios frontal y trasero entre el piso y el retén del carril (C) sean de aproximadamente 8.0 mm.

- a: Cuando se utiliza el alimentador de papel de 3000 hojas
b: Cuando se utiliza el alimentador de papel de 500 hojas x 2

10. Inserte el carril de guía (D) en la parte inferior del finalizador de documentos (A).

9. Bringen Sie die Schienenhalterung (C) am MFP mit zwei M4 × 10 Verbundschrauben (F) so an, daß die vorderen und hinteren Abstände zwischen Boden und Schienenhalterung (C) etwa 8.0 mm betragen.

- a: Bei Verwendung des Papiervorschubs für 3000 Blätter
b: Bei Verwendung des Papiervorschubs für 500 Blätter x 2

10. Die Führungsschiene (D) in das Unterteil des Dokument Finishers (A) einschieben.

9. Assicurare il fermo della guida (C) all'MFP utilizzando le due viti di serraggio M4 × 10 (F), in modo che la distanza anteriore e posteriore tra il pavimento ed il fermo della guida (C) sia di circa 8.0 mm.

- a: Quando si utilizza l'alimentatore di carta da 3000 fogli
b: Quando si utilizza l'alimentatore di carta da 500 fogli x 2

10. Inserire la guida della rotaia (D) nella parte inferiore della finitrice di documenti (A).

9. 用两个 M4 × 14 固结螺钉 (F) 将轨道座 (C) 固定于 MFP 主机上, 此时, 轨道座 (C) 与地板之间的距离应约为 8.0 毫米。

- a: 使用 3000 张供纸盒时
b: 使用 500 张 × 2 个供纸盒时

10. 将导向轨道 (D) 插入装订器 (A) 的底部。

9. レール取付板 (C) と床面の前後隙間が約 8.0mm になるように、レール取付板 (C) を MFP 本体にビス M4 × 14 バインド (F) 2 本で固定する。

- a: 3000 枚ペーパーフィーダの場合
b: 500 枚 × 2 ペーパーフィーダの場合

10. ドキュメントフィニッシャ (A) の底部にガイドレール (D) を挿入する。

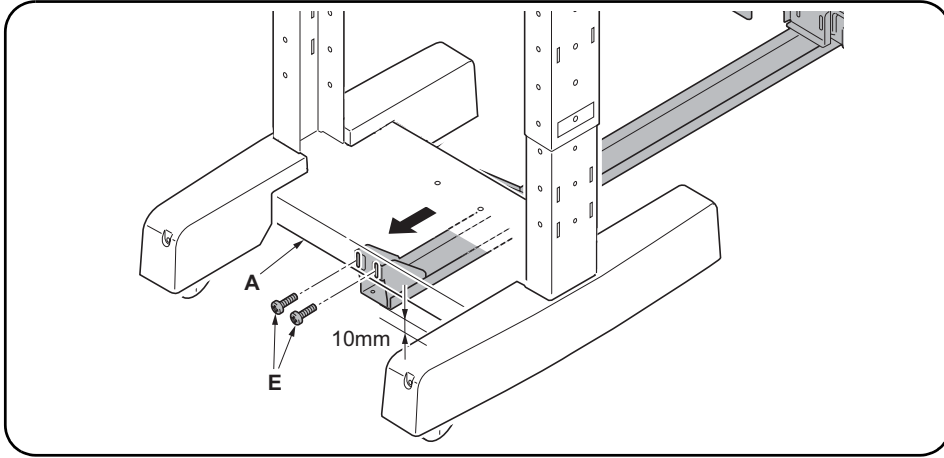

Fitting and adjusting the guide rail

11. While pressing the guide rail (D) to the document finisher (A) so that the gap between the guide rail (D) and the floor is approximately 10 mm, secure it using two M4 x 6 binding screws (E).

Note

If the guide rail is not properly adjusted, the guide rail may not move when the document finisher is separated.

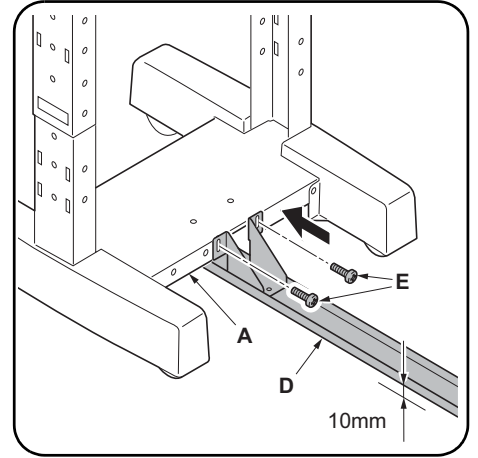

12. Secure the guide rail (D) with the two M4 x 6 binding screws (E) so that there is a gap of approximately 10 mm between the rail and the floor.

Fixation et réglage de la glissière

11. Tout en pressant la glissière (D) contre le retoucheur de document (A) de façon que l'écart entre la glissière (D) et le sol soit d'environ 10 mm, la fixer à l'aide de deux vis de raccordement M4 x 6 (E).

Remarque

Si la glissière n'est pas réglée correctement, la glissière risquera de ne pas se déplacer lorsque le retoucheur de document sera séparé.

12. Fixer la glissière (D) à l'aide des deux vis de fixation M4 x 6 (E) de sorte à ménager un espace d'environ 10 mm entre la glissière et le sol.

Fijación y ajuste del carril de guía

11. Mientras presiona el carril de guía (D) en el finalizador de documentos (A) para que la separación entre el carril de guía (D) y el piso sea de unos 10 mm, asegúrelo utilizando dos tornillos de fijación M4 x 6 (E).

Nota

Si el carril de guía no está bien ajustado, el carril de guía puede no moverse cuando se separa el finalizador de documentos.

12. Asegure el carril guía (D) con dos tornillos de sujeción M4 x 6 (E) de forma tal que exista un espacio de aproximadamente 10 mm entre el carril y el piso.

Anbringen und Einstellen der Führungsschieneneinheit

11. Die Führungsschiene (D) gegen den Dokument Finisher (A) gedrückt halten, so dass der Abstand zwischen der Führungsschiene (D) und dem Boden ca. 10 mm beträgt, und mit zwei M4 x 6 Befestigungsschrauben (E) sichern.

Hinweis

Falls die Führungsschieneneinheit nicht korrekt eingestellt ist, bewegt sie sich beim Trennen des Dokument Finishers eventuell nicht.

12. Die Führungsschieneneinheit (D) mit den beiden M4 x 6 Verbundschrauben (E) so sichern, dass ein Abstand von etwa 10 mm zwischen Schiene und Boden vorhanden ist.

Montaggio e regolazione della guida della rotaia

11. Mentre si tiene premuta la guida della rotaia (D) alla finitrice di documenti (A) in modo che lo spazio tra la guida della rotaia (D) e il pavimento sia di circa 10 mm, fissarla a mezzo di due viti di serraggio M4 x 6 (E).

Nota

Se la guida della rotaia non è regolata correttamente, potrebbe non muoversi quando il separatore la finitrice di documenti verrà staccato.

12. Fissare la guida della rotaia (D) con le due viti di serraggio M4 x 6 (E) in modo che ci sia una distanza di circa 10 mm tra la rotaia e il pavimento.

导向轨道的安装调整

11. 调整导向轨道 (D) 与地板之间的间距为 10 毫米左右, 将导向轨道 (D) 插入装订器 (A) 到底, 用两个 M4 x 6 固结螺钉 (E) 进行固定。

注意

如果不能正确调整导向轨道的话, 在分离装订器时, 可能会发生导向轨道不能移动的情况。

12. 用 2 个 M4 x 6 固结螺钉 (E) 将导向轨道 (D) 固定, 确保轨道和地面之间有约 10 毫米的距离。

ガイドレールの取付調整

11. ガイドレール (D) と床面の隙間が約 10mm になるように、ガイドレール (D) をドキュメントフィニッシャー (A) に突き当てながら、ビス M4 x 6 バインド (E) 2 本で固定する。

注意

正しく調整しないと、ドキュメントフィニッシャーの切り離し時、ガイドレールが動かない恐れがある。

12. ガイドレール (D) と床面の隙間が約 10mm になるように、ビス M4 x 6 バインド (E) 2 本で固定する。

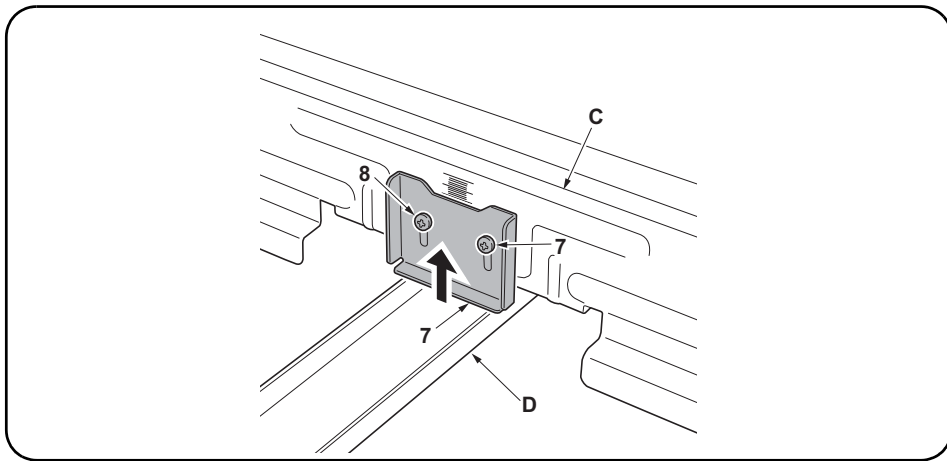

13. Loosen temporarily the two screws (8) that secure the sheet metal (7) of the rail mounting plate (C) on the MFP, raise the sheet metal (7) by two divisions of the scale from the guide rail (D), and tighten the two screws (8).

Note

If the guide rail (D) is not adjusted correctly, it will not move and could cause the document finisher to fall over.

14. Slide the document finisher to engage it with the latch catch of the MFP. If the document finisher and the MFP do not engage securely, perform the following document finisher height adjustment.

13. Desserrer provisoirement les deux vis (8) qui fixent la feuille métallique (7) de la plaque de montage du rail (C) sur le MFP, élever la feuille métallique (7) de deux crans sur l'échelle de la glissière (D), puis resserrer les deux vis (8).

Remarque

Si la glissière (D) n'est pas ajustée proprement, elle ne va pas se déplacer et le retoucheur de document risque de tomber.

14. Faire glisser le retoucheur de document pour l'engager dans le pontet du loquet du MFP. Si le retoucheur de document et le MFP ne s'engagent pas correctement, effectuer le réglage de hauteur suivant sur le retoucheur de document.

13. Afloje temporalmente los dos tornillos (8) que aseguran la hoja de metal (7) de la placa de montaje de carril (C) en el MFP, levante la hoja de metal (7) con dos divisiones de la escala del carril de guía (D) y apriete los dos tornillos (8).

Nota

Si no se ajusta correctamente el carril guía (D), éste no se moverá y puede provocar que el finalizador de documentos se caiga.

14. Deslice el finalizador de documentos hasta que enganche con el cerrojo del MFP. Si el finalizador de documentos y el MFP no se acoplan de manera segura, realice el siguiente ajuste de la altura del finalizador de documentos.

13. Die zwei Schrauben (8), die das Blech (7) der Schienenmontageplatte (C) am MFP sichern, vorübergehend lösen, das Blech (7) um zwei Teilstriche der Skala von der Führungsschiene (D) aus anheben, und die zwei Schrauben (8) wieder anziehen.

Hinweis

Falls die Führungsschieneneinheit (D) nicht ordnungsgemäß eingestellt ist, kann sie sich nicht bewegen und könnte dazu führen, dass der Dokument Finisher umfällt.

14. Den Dokument Finisher verschieben, um ihn mit dem Riegelschloßbausatz des MFP in Eingriff zu bringen. Wenn der Dokument Finisher und der MFP nicht richtig ineinander eingreifen, führen Sie die folgende Höheneinstellung für den Dokument Finisher aus.

13. Allentare temporaneamente le due viti (8) che fissano il foglio metallico (7) della piastra di montaggio della rotaia (C) dell'MFP, sollevare il foglio di metallo (7) di due posizioni sulla guida della rotaia (D) e serrare le due viti (8).

Nota

Se la guida della rotaia (D) non è regolata correttamente, essa non si muoverà e potrà causare la caduta della finitrice di documenti.

14. Fare scivolare la finitrice di documenti per farla innestare con il dispositivo di arresto dell'MFP. Qualora la finitrice di documenti e l'MFP non si innestino saldamente, osservare la seguente procedura di regolazione dell'altezza della finitrice di documenti.

13. 松动固定在 MFP 主机侧轨道座 (C) 的金属板 (7) 上的两支固接螺钉 (8), 在金属板 (7) 碰及导向轨道 (D) 的状态下, 抬升到第 2 个刻度的位置, 然后用两支螺钉 (8) 固定。

注意

如果没有正确调整导向轨道, 它将无法移动, 并有可能导致装订器倾覆。

14. 滑动装订器并连接于 MFP 主机的挂钩承支架上。如没有完全连接, 请按下述步骤调整装订器的高度。

13. MFP 本体側のレール取付板 (C) の板金 (7) を固定しているビス (8) 2 本をいったん緩め、板金 (7) をガイドレール (D) に当てた状態から 2 目盛り上の位置にあげて、ビス (8) 2 本を固定する。

注意

正しく調整しないと、ガイドレールが動かない。又ドキュメントフィニッシャが倒れる恐れがある。

14. ドキュメントフィニッシャをスライドさせて MFP 本体のラッチ受け板に連結させる。確実に連結しない場合は、次のドキュメントフィニッシャの高さ調整をおこなう。

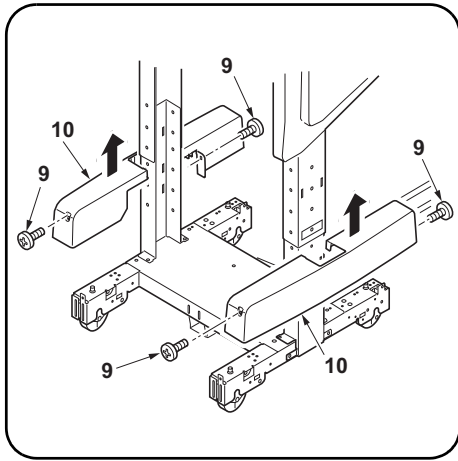

Adjusting the height of the document finisher

1. Remove two screws (9) and remove the covers (10) from the document finisher (A).

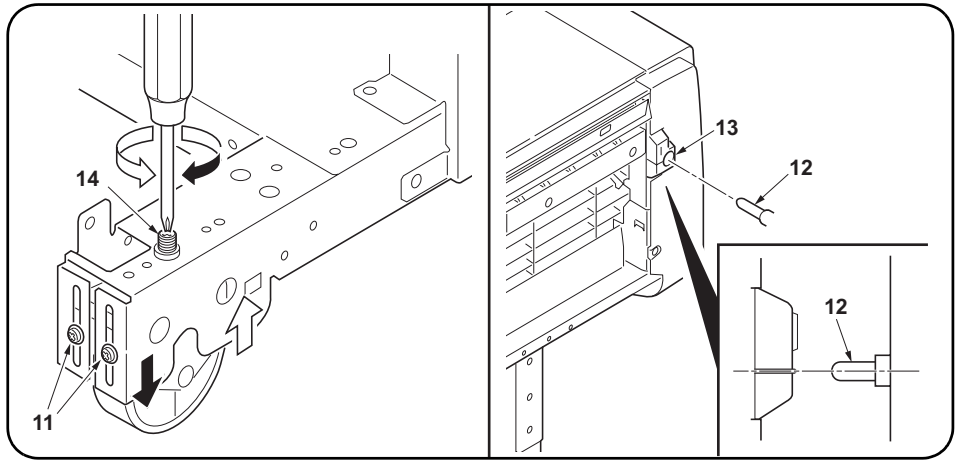

2. Loosen the two screws (11) on the rear right caster of the document finisher (A). Adjust the height of the rear right caster by turning its adjustment bolt (14) using a cross-headed screwdriver so that the axis of the pin (12) of the latch catch is aligned with the marking of the slot (13) of the document finisher (A) when the document finisher (A) is joined to the MFP (viewed from the machine front). Turning the adjustment bolt (14) clockwise lifts the document finisher (A), while turning it counterclockwise lowers the document finisher (A).

Réglage de la hauteur du retoucheur de document

1. Déposer les deux vis (9) et les capots (10) du retoucheur de document (A).

2. Desserrer les deux vis (11) de la roulette arrière droite du retoucheur de document (A). Régler la hauteur de la roulette arrière droite en tournant son boulon de réglage (14) à l'aide d'un tournevis cruciforme de manière que l'axe de la broche (12) du pontet du loquet soit aligné sur la marque de la fente (13) du retoucheur de document (A) lorsque le retoucheur de document (A) est fixé au MFP (vue à partir de l'avant de la machine). Si l'on tourne le boulon de réglage (14) dans le sens des aiguilles d'une montre, le retoucheur de document (A) s'élève; si on le tourne dans le sens inverse des aiguilles d'une montre, le retoucheur de document (A) s'abaisse.

Ajuste de altura del finalizador de documentos

1. Quite los dos tornillos (9) y desmonte las cubiertas (10) del finalizador de documentos (A).

2. Afloje los dos tornillos (11) en la rueda trasera del finalizador de documentos (A). Ajuste la altura de la rueda trasera derecha girando su perno de ajuste (14) utilizando un destornillador de punta en cruz para que el eje del pasador (12) en el pestillo esté alineado con la marca de la ranura (13) del finalizador de documentos (A) cuando el finalizador de documentos (A) esté unido a el MFP (vista del frente de la máquina). Al girar el perno de ajuste (14) en la dirección de las manecillas del reloj se levanta el finalizador de documentos (A) y al girar contra las manecillas del reloj baja el finalizador de documentos (A).

Einstellen der Dokument Finisherhöhe

1. Die beiden Schrauben (9) entfernen und die Abdeckungen (10) vom Dokument Finisher (A) abnehmen.

2. Die zwei Schrauben (11) an der hinteren rechten Laufrolle des Dokument Finishers (A) lösen. Die Höhe der hinteren rechten Laufrolle durch Drehen ihrer Einstellschraube (14) mit einem Kreuzschlitzschraubenzieher so einstellen, dass die Achse des Stifts (12) der Verriegelungsklaue auf die Markierung des Schlitzes (13) des Dokument Finishers (A) ausgerichtet ist, wenn der Dokument Finisher (A) an den MFP angesetzt ist (von der Gerätevorderseite gesehen). Durch Drehen der Einstellschraube (14) im Uhrzeigersinn wird der Dokument Finisher (A) angehoben, während er durch Drehen entgegen dem Uhrzeigersinn abgesenkt wird.

Regolazione dell'altezza della finitrice di documenti

1. Rimuovere le due viti (9) e quindi rimuovere i coperchi (10) dalla finitrice di documenti (A).

2. Allentare le due viti (11) sulla ruota orientabile posteriore destra della finitrice di documenti (A). Regolare l'altezza della ruota orientabile posteriore destra ruotandone il suo bullone di regolazione (14) a mezzo di un cacciavite a croce, in modo che l'asse del perno (12) del dispositivo di arresto risulti allineato ai contrassegni del foro (13) della finitrice di documenti (A) una volta che la finitrice stessa (A) viene unita all'MFP (vista dal lato frontale della macchina). Ruotando il bullone di regolazione (14) in senso orario si solleva la finitrice di documenti (A), mentre ruotandolo in senso antiorario si abbassa la finitrice di documenti (A).

[調整装订器的高度]

1. 拆下 2 个螺钉 (9), 然后从装订器 (A) 上拆下盖板 (10)。

2. 将装订器 (A) 右后侧滚轮的支固定螺钉 (11) 拧松。将装订器 (A) 与 MFP 主机连接, 为了使 (从前面看时) 挂钩支架销 (12) 的中心与装订器 (A) 的长孔 (13) 的刻度相对准, 用十字螺丝刀旋转调节用螺钉 (14), 对右后侧滚轮的高度进行调整。将调节用螺钉 (14) 往顺时针方向旋转时, 可调高装订器 (A), 而往逆时针方向旋转螺钉时, 则可调低高度。

[ドキュメントフィニッシャの高さ調整]

1. ビス (9) 各 2 本を外し、ドキュメントフィニッシャ (A) のカバー (10) を取り外す。

2. ドキュメントフィニッシャ (A) 右後のキャストの固定ビス (11) 2 本を緩める。ドキュメントフィニッシャ (A) を MFP 本体に連結し、前から見た時に、ラッチ受け板のピン (12) の中心が、ドキュメントフィニッシャ (A) の長穴 (13) の刻印に合うように、プラスドライバーを用いて調整用ボルト (14) を回し、右後のキャストの高さ調整をおこなう。調整用ボルト (14) を時計方向に回すとドキュメントフィニッシャ (A) が上がり、反時計方向に回すと下がる。

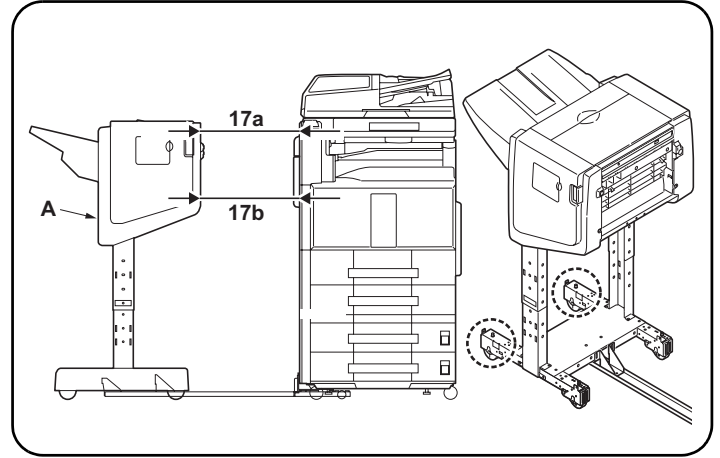
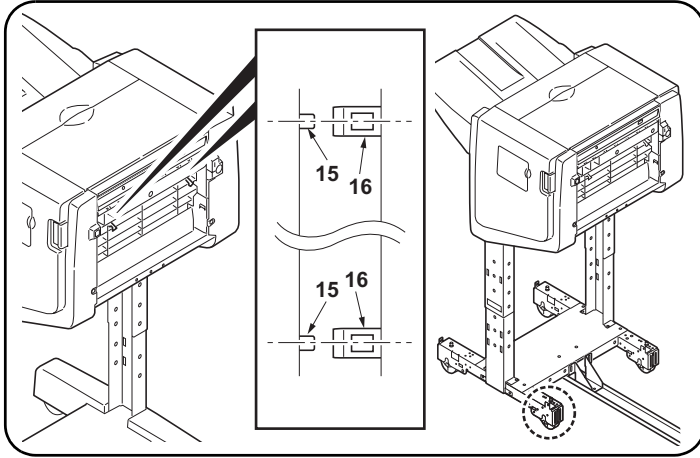

3. Adjust the height of the front right caster in the same manner as in step 2 so that each center of the hooking portions (16) of the latch catch is aligned with the center of the two hooks (15) on the document finisher (A) when the document finisher (A) is joined to the MFP (viewed from above).

4. Adjust the height of the left two casters in the same manner as in step 2 so that the gaps (17a) and (17b) between the document finisher (A) and the MFP are the same when the document finisher (A) is detached from the MFP.
5. Reattach the removed parts to their original positions.

3. Régler la hauteur de la roulette avant droite en procédant comme à l'étape 2, de manière que chacun des centres des parties d'accrochage (16) du pontet du loquet soit aligné sur le centre des deux crochets (15) du retoucheur de document (A) lorsque le retoucheur de document (A) est fixé au MFP (vue à partir du haut).

4. Régler la hauteur des deux roulettes gauches en procédant comme à l'étape 2, de manière que les écarts (17a) et (17b) entre le retoucheur de documents (A) et la MFP soient identiques lorsque le retoucheur de documents (A) est détaché de MFP.
5. Remettez les pièces enlevées à leur position d'origine.

3. Ajuste la altura de la rueda delantera derecha de la misma forma que en el paso 2 para que cada centro de las partes de enganche (16) de cada pestillo esté alineado con el centro de los dos ganchos (15) en el finalizador de documentos (A) cuando el finalizador de documentos (A) está nido a el MFP (vista de arriba).

4. Ajuste la altura de las dos ruedas izquierdas de la misma forma que en el paso 2 para que las separaciones (17a) y (17b) entre el finalizador de documentos (A) y la MFP sean las mismas cuando el finalizador de documentos (A) está soltado de la MFP.
5. Vuelva a instalar las piezas desmontadas en sus posiciones originales.

3. Die Höhe der vorderen rechten Laufrolle auf die in Schritt 2 beschriebene Weise einstellen, so dass die Mitte der Rasten (16) der Verriegelungsklaue auf die Mitte der zwei Haken (15) am Dokument Finisher (A) ausgerichtet ist, wenn der Dokument Finisher (A) an den MFP angesetzt ist (von oben gesehen).

4. Die Höhe der beiden linken Laufrollen auf die in Schritt 2 beschriebene Weise einstellen, so dass die Abstände (17a) und (17b) zwischen dem Dokument Finisher (A) und dem MFP gleich groß sind, wenn der Dokument Finisher (A) vom MFP abgenommen wird.
5. Die entfernten Teile wieder an ihren ursprünglichen Positionen anbringen.

3. Regolare l'altezza della ruota orientabile anteriore destra allo stesso modo descritto al passo 2, in modo che ciascun centro delle parti di aggancio (16) del dispositivo di arresto sia allineato al centro dei due ganci (15) della finitrice di documenti (A), una volta che la finitrice di documenti (A) viene unita all'MFP (vista dall'alto).

4. Regolare l'altezza delle due ruote orientabili sinistre allo stesso modo descritto al passo 2, in modo che le distanze (17a) e (17b) tra la finitrice di documenti (A) e l'MFP siano le stesse una volta che la finitrice di documenti (A) viene separata dall'MFP.
5. Rimontare le parti rimosse nelle loro posizioni originali.

3. 将装订器 (A) 与 MFP 主机连接, 使 (从上面看时) 装订器 (A) 的两个挂钩 (15) 与挂钩承支架的孔 (16) 中心相对准, 并按与步骤 2 相同的方法来调整前右侧滚轮的高度。

4. 按照步骤 2 中相同的方式调整左侧两个轮脚的高度, 使得装订器 (A) 和 MFP 主机之间的间隙 (17a) 和 (17b) 在从 MFP 主机上拆下装订器 (A) 时为相同的。
5. 卸下的部件按原样装上。

3. ドキュメントフィニッシャ (A) を MFP 本体に連結し、上から見た時に、ドキュメントフィニッシャ (A) のフック (15) 2ヶ所とラッチ受け板の引っ掛け部 (16) の中心が合うように、手順 2 と同様にして右前のキャスタの高さ調整をおこなう。

4. ドキュメントフィニッシャ (A) を MFP 本体から切り離れた時に、ドキュメントフィニッシャ (A) と MFP 本体の間隔 (17a) (17b) が等しくなるように、手順 2 と同様にして左側のキャスタ 2 カ所の高さ調整をおこなう。
5. 取り外した部品を元通りに取り付ける。

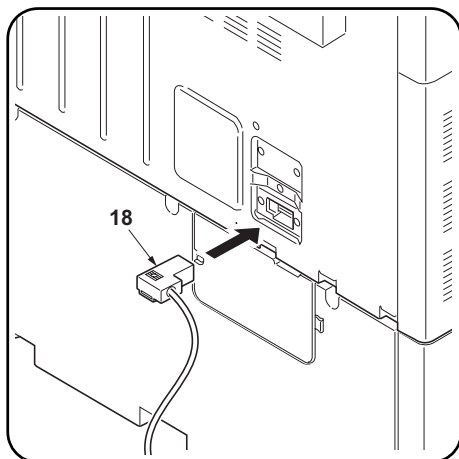

6. After completing the installation, return to pages 7 to 8 of the installation procedure and loosen the four M4 x 6 binding screws (E) in steps 11 to 12. Then loosen the two screws (8) in step 13 and adjust the guide rail installation.

Connecting the signal cable

1. Connect the signal cable (18) of the document finisher (A) to the MFP.

Operation check

1. Insert the MFP power plug to the wall outlet and turn the main power switch on.
2. Check that the paper is fed and that the document finisher (A) operates correctly.

6. Une fois l'installation terminée, revenir aux pages 7 et 8 du processus d'installation et desserrer les quatre vis de fixation M4 x 6 binding screws (E) aux étapes 11 et 12. Desserrer ensuite les deux vis (8) à l'étape 13 et régler l'installation de la glissière.

Connexion du câble d'interconnexion

1. Connecter le câble d'interconnexion (18) du retoucheur de document (A) au MFP.

Vérification du fonctionnement

1. Insérer la fiche d'alimentation du MFP ou imprimante dans la prise murale et mettre l'interrupteur principal sous tension.
2. Vérifier que le papier est fourni et que le retoucheur de document (A) fonctionne correctement.

6. Después de finalizada la instalación, vuelva a las páginas 7 a 8 del procedimiento de instalación y afloje los cuatro tornillos de sujeción M4 x 6 (E) de los pasos 11 y 12. Después, afloje los dos tornillos (8) del paso 13 y ajuste la instalación del carril guía.

Conexión del cable de señal

1. Conecte el cable de señal (18) del finalizador de documentos (A) en el MFP.

Comprobación operacional

1. Inserte el enchufe del MFP o impresora en el receptáculo de la pared y encienda el interruptor principal.
2. Asegúrese de que avance el papel y verifique que el finalizador de documentos (A) funcione correctamente.

6. Nach Abschluss der Installation noch einmal zu den Seiten 7 bis 8 der Installationsprozedur zurückkehren und die vier M4 x 6 Verbundschrauben (E) gemäß Schritt 11 bis 12 lösen. Dann die beiden Schrauben (8) in Schritt 13 lösen und die Befestigungsposition der Führungsschieneneneinheit korrigieren.

Anschließen des Signalkabels

1. Das Signalkabel (18) des Dokument Finishers (A) an den MFP anschließen.

Betriebstest

1. Stecken Sie den Netzstecker des MFP oder Drucker in die Netzsteckdose ein und schalten Sie den Hauptschalter ein.
2. Vergewissern dass der Papiervorschub funktioniert und dass der Dokument Finisher (A) einwandfrei funktioniert.

6. Dopo aver completato il montaggio, ritornare alle pagine 7 e 8 della procedura di installazione e allentare le quattro viti di serraggio M4 x 6 (E) nei passi 11 e 12. Quindi allentare le due viti (8) nel passo 13 e regolare l'installazione della guida della rotai.

Connessione del cavo del segnale

1. Collegare il cavo del segnale (18) della finitrice di documenti (A) all'MFP.

Controllo del funzionamento

1. Inserire il cavo di alimentazione dell'MFP o stampatore nella presa di rete e quindi premete il pulsante generale di accensione.
2. Verificare che la carta di prova sia alimentata e controllare che la finitrice di documenti (A) funzioni correttamente.

6. 安装完成后，返回安装手册的第 7、8 页，把步骤 11 ~ 12 的 4 个 M4x6 固结螺钉 (E) 和步骤 13 中的 2 个螺钉 (8) 拧松后，对导向轨道进行安装调整。

[连接信号电线]

1. 装订器 (A) 的信号电线 (18) 连接在 MFP 主机上。

[确认运作]

1. 将 MFP 主机的电源插头插入插座后，开启总电源。
2. 确认已经送纸并且装订器 (A) 运行正常。

6. 作業終了後、設置手順書の 7 ~ 8 頁に戻り、手順 11 ~ 12 のビス M4 x 6 バインド (E) 4 本及び、手順 13 のビス (8) 2 本を緩め、ガイドレールの取付調整をおこなう。

[信号線の接続]

1. ドキュメントフィニッシャ (A) の信号線 (18) を MFP 本体に接続する。

[動作確認]

1. MFP 本体の電源プラグをコンセントに差し込み、主電源スイッチを ON にする。
2. 通紙確認をおこない、ドキュメントフィニッシャ (A) が正常に動作することを確認する。

INSTALLATION GUIDE FOR BUILT-IN FINISHER

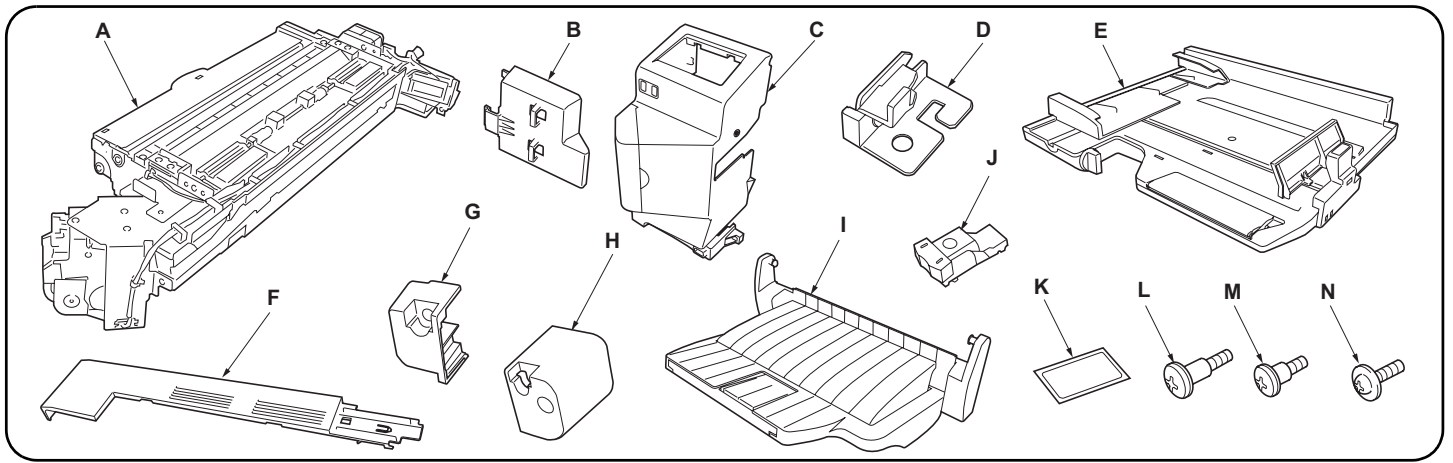

English

Supplied parts

A Paper conveying unit 1
 B Sub staple cover 1
 C Staple cover 1
 D Hook holder 1
 E Finisher process table 1

F Upper left cover 1
 G Front eject cover 1
 H Rear eject cover 1
 I Finisher tray 1
 J Staple cartridge 1
 K Blindfold seal 1
 L Large pin 1
 M Small pin 1
 N M3 x 6 screw 3

Français

Pièces fournies

A Unité de transport du papier 1
 B Capot de l'agrafeuse auxiliaire 1
 C Capot de l'agrafeuse 1
 D Support de crochet 1
 E Table de processus du module de finition 1

F Capot supérieur gauche 1
 G Capot d'éjection avant 1
 H Capot d'éjection arrière 1
 I Plateau du module de finition 1
 J Cartouche d'agrafes 1
 K Étiquette de masquage 1
 L Grande goupille 1
 M Petite goupille 1
 N Vis M3 x 6 3

Español

Partes suministradas

A Unidad de transporte de papel 1
 B Cubierta secundaria de grapas 1
 C Cubierta de grapas 1
 D Soporte de gancho 1
 E Tabla de proceso de finalizador 1

F Cubierta superior izquierda 1
 G Cubierta de expulsión frontal 1
 H Cubierta de expulsión trasera 1
 I Bandeja de finalizador 1
 J Cartucho de grapas 1
 K Sello ciego 1
 L Pasador grande 1
 M Pasador pequeño 1
 N Tornillo M3 x 6 3

Deutsch

Gelieferte Teile

A Papierfördereinheit 1
 B Heferhilfsabdeckung 1
 C Heferabdeckung 1
 D Hakenhalter 1
 E Finisher-Druckablage 1

F Obere linke Abdeckung 1
 G Frontauswurfabdeckung 1
 H Rückauswurfabdeckung 1
 I Finisher-Ablage 1
 J Heftklammermagazin 1
 K Blindaufkleber 1
 L Großer Stift 1
 M Kleiner Stift 1
 N M3 x 6 Schraube 3

Italiano

Parti di forniture

A Unità di trasporto carta 1
 B Coperchio secondario della pinzatrice 1
 C Coperchio pinzatrice 1
 D Supporto a gancio 1
 E Tabella di elaborazione del finitore 1

F Coperchio superiore sinistro 1
 G Coperchio anteriore di espulsione carta 1
 H Coperchio posteriore di espulsione carta 1
 I Vassoio finitore 1
 J Cartuccia punti metallici 1
 K Sigillo mascherina 1
 L Perno grande 1
 M Perno piccolo 1
 N Vite M3 x 6 3

简体中文

同装品

A 输送组件 1
 B 副装订器盖板 1
 C 装订器盖板 1
 D 钩夹 1

E 装订分页器处理托盘 1
 F 左上盖板 1
 G 排纸盖板(前) 1
 H 排纸盖板(后) 1
 I 装订分页器托盘 1
 J 订书钉盒 1
 K 标贴 1
 L 大卡销 1

M 小卡销 1
 N 螺丝 M3 x 6 3

日本語

同梱品

A 搬送ユニット 1
 B サブステーブルカバー 1
 C ステープルカバー 1
 D フックホルダ 1

E フィニッシャー処理トレイ 1
 F 左上カバー 1
 G 排出カバー前 1
 H 排出カバー後 1
 I フィニッシャートレイ 1
 J ステープルカートリッジ 1
 K シール 1
 L ピン大 1

M ピン小 1
 N ビス M3 x 6 3

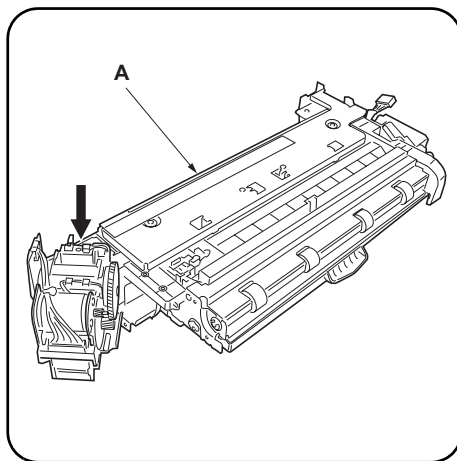

Precautions

- Be sure to remove any tape and/or cushioning material from supplied parts.
- Before installing the finisher, be sure to turn the main power switch of the machine off and unplug the power cable from the wall outlet.

Important

When placing the paper conveying unit (A) on the floor or the like, be sure to place it upside down because the staple mounting plate may be deformed.

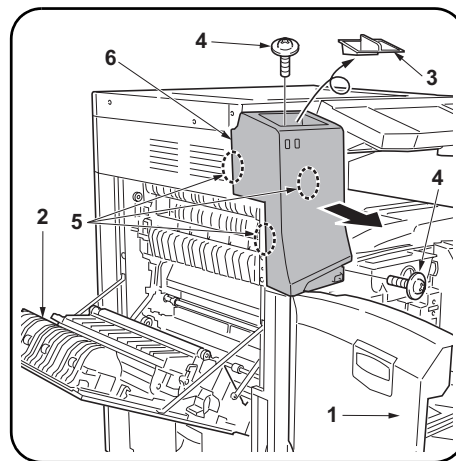

Procedure

Opening the covers

- Open the front cover (1) and left cover 1 (2).
- Remove the clip holder (3).
- Remove two screws (4) and release three latches (5) to remove the cover (6).

Précautions

- Veillez à retirer les morceaux de bande adhésive et/ou les matériaux de rembourrage des pièces fournies.
- Avant d'installer le module de finition, veillez à mettre la machine hors tension et à débrancher le câble d'alimentation de la prise murale.

Important

Lorsque vous placez l'unité de transport du papier (A) sur le sol ou sur une surface équivalente, veillez à la placer sens dessus dessous, car la plaque de montage d'agrafes risque d'être déformée.

Procédure

Retrait des capots

- Ouvrez le capot avant (1) et le capot gauche 1 (2).
- Retirez le support à pince (3).
- Retirez deux vis (4) et libérez trois verrous (5) pour retirer le capot (6).

Precauciones

- Asegúrese de despegar todas las cintas y/o material amortiguador de las partes suministradas.
- Antes de instalar el finalizador, asegúrese de desconectar el interruptor principal de la máquina y desenchufar el cable eléctrico del tomacorriente de la pared.

Importante

Cuando coloca la unidad de transporte de papel (A) en el piso o similar, asegúrese de colocarlo invertido porque la placa de montaje de grapas puede deformarse.

Procedimiento

Desmontaje de las cubiertas

- Abra la cubierta frontal (1) y la cubierta izquierda 1 (2).
- Desmonte el soporte de clip (3).
- Saque los dos tornillos (4) y suelte los tres pestillos (5) para desmontar la cubierta (6).

Vorsichtsmaßnahmen

- Entfernen Sie Klebeband und/oder Dämpfungsmaterial vollständig von den mitgelieferten Teilen.
- Schalten Sie unbedingt den Betriebsschalter der Maschine aus, und trennen Sie das Netzkabel von der Netzsteckdose, bevor Sie den Finisher installieren.

Wichtig

Wenn die Papierfördereinheit (A) auf den Boden oder dergleichen gestellt wird, muss sie auf den Kopf gestellt werden, weil sonst die Heftermontageplatte verformt werden kann.

Verfahren

Entfernen der Abdeckungen

- Die Frontabdeckung (1) und die linke Abdeckung 1 (2) öffnen.
- Den Büroklammerhalter (3) entfernen.
- Die zwei Schrauben (4) herausdrehen, und die drei Rasten (5) lösen, um die Abdeckung (6) abzunehmen.

Precauzioni

- Accertarsi di rimuovere tutti i nastri adesivi e/o il materiale di imbottitura dalle parti fornite.
- Prima di installare il finitore, assicurarsi di spegnere l'interruttore principale di alimentazione della macchina e scollegare la spina del cavo di alimentazione dalla presa a muro della rete elettrica.

Importante

Quando collocate l'unità di trasporto della carta (A) sul pavimento o in un altro luogo simile, accertatevi che sia posto capovolto, perché la piastra di montaggio della pinzatrice potrebbe deformarsi.

Procedura

Rimozione dei coperchi

- Aprire il coperchio anteriore (1) e il coperchio sinistro 1 (2).
- Rimuovete il contenitore delle graffette (3).
- Togliete due viti (4) e rilasciate i tre fermi (5) per rimuovere il coperchio (6).

注意事項

- 如果同裝品上帶有固定膠帶、緩衝材料時務必揭下。
- 安裝裝訂分頁器時，必須先關閉機器主機的主電源開關，並拔下電源插頭後，再進行安裝作業。

注意事項

將輸送組件 (A) 放在地板等上時，為了防止裝訂器安裝板變形，必須翻過來放置。

安裝步驟

拆下蓋板類

- 打開前蓋板 (1) 和左蓋板 1 (2)。
- 拆下夾子盒 (3)。
- 卸下 2 個螺絲 (4)，鬆解 3 處嵌入板 (5)，然後，取下蓋板 (6)。

注意事項

- 同梱品に固定テープ、緩衝材が付いている場合は必ず取り外すこと。
- フィニッシャを設置する場合は、機械本体の主電源スイッチを OFF にし、電源プラグを抜いてから作業をおこなう。

注意事項

搬送ユニット (A) を床などに置く場合は、ステーブル取付板変形防止のため必ず裏返しにして置く。

設置手順

カバー類の取り外し

- 前カバー (1) および左カバー 1 (2) を開く。
- クリップ入れ (3) を取り外す。
- ビス (4) 2 本を外し、はめ込み (5) 3 箇所を解除してカバー (6) を取り外す。

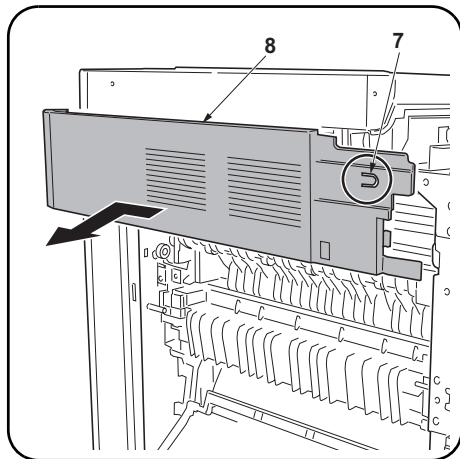

4. Release the latch (7) using a flat-head screwdriver to remove the cover (8).

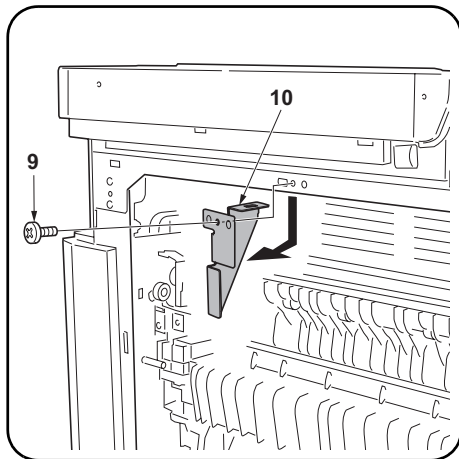

5. Remove the screw (9) to remove the metal plate (10). The removed metal plate (10) is no longer required.

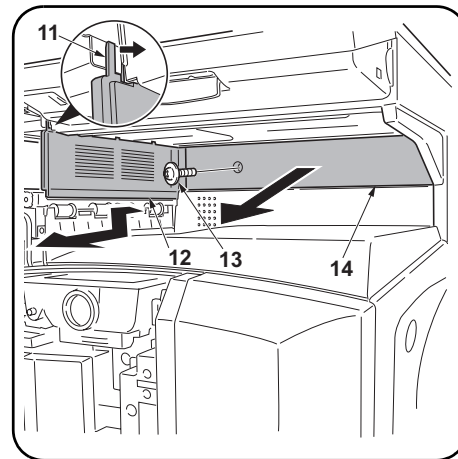

6. Release the latch (11) using a flat-head screwdriver and slide the cover (12) to the front to remove.
7. Remove the screw (13) to remove the cover (14).

4. Libérez le verrou (7) à l'aide d'un tournevis à tête plate pour retirer le capot (8).

5. Retirez la vis (9) pour déposer la plaque métallique (10). La plaque métallique déposée (10) n'est plus nécessaire.

6. Libérez le verrou (11) à l'aide d'un tournevis à tête plate, puis faites glisser le capot (12) vers l'avant pour le déposer.
7. Retirez la vis (13) pour déposer le capot (14).

4. Suelte el pestillo (7) utilizando un destornillador de cabeza plana para desmontar la cubierta (8).

5. Quite el tornillo (9) para desmontar la placa de metal (10). La placa de metal desmontada (10) ya no es necesaria.

6. Suelte el pestillo (11) utilizando un destornillador de cabeza plana y deslice la cubierta (12) hacia delante para desmontarla.
7. Saque el tornillo (13) para desmontar la cubierta (14).

4. Die Raste (7) mit einem Flachsraubenzieher lösen, um die Abdeckung (8) abzunehmen.

5. Die Schraube (9) herausdrehen, um die Metallplatte (10) abzunehmen. Die abgenommene Metallplatte (10) wird nicht mehr benötigt.

6. Die Raste (11) mit einem Flachsraubenzieher lösen, und die Abdeckung (12) nach vorn schieben, um sie abzunehmen.
7. Die Schraube (13) herausdrehen, um die Abdeckung (14) abzunehmen.

4. Rilasciate il fermo (7) utilizzando un giravite a punta piatta per rimuovere il coperchio (8).

5. Rimuovere la vite (9) per togliere la piastra di metallo (10). La piastra di metallo (10) rimossa non è più necessaria.

6. Rilasciate il fermo (11) utilizzando un giravite a punta piatta e fate scivolare il coperchio (12) verso il lato anteriore per rimuoverlo.
7. Togliete la vite (13) per rimuovere il coperchio (14).

4. 用一字形螺丝刀等松解嵌入板 (7), 取下盖板 (8)。

5. 卸下 1 个螺丝 (9), 取下金属件 (10)。不安装金属件 (10)。

6. 用一字形螺丝刀等松解嵌入板 (11), 将盖板 (12) 向跟前拉并取下。
7. 卸下 1 个螺丝 (13), 取下盖板 (14)。

4. はめ込み (7) をマイナスドライバーなどで解除し、カバー (8) を取り外す。

5. ビス (9) 1 本を外し、金具 (10) を取り外す。金具 (10) は取り付けない。

6. はめ込み (11) をマイナスドライバーなどで解除し、カバー (12) を手前側に引いて取り外す。
7. ビス (13) 1 本を外し、カバー (14) を取り外す。

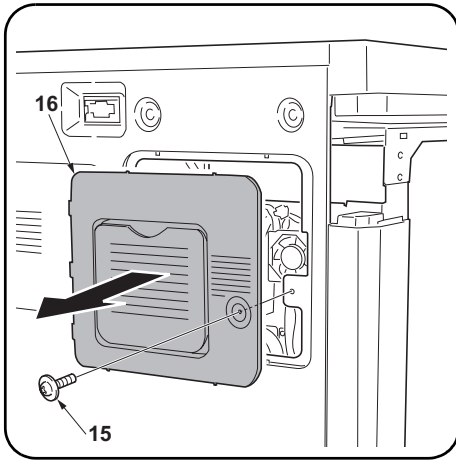

8. Remove the screw (15) from the rear side of the machine to remove the cover (16).

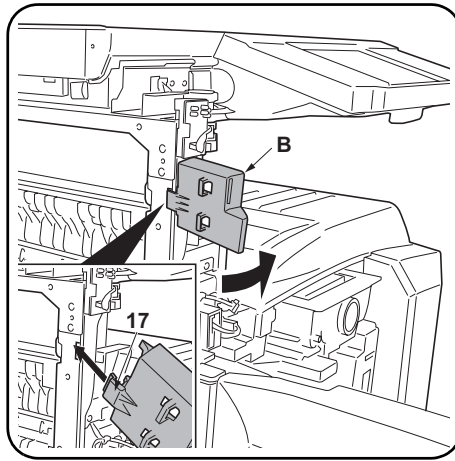

Attaching the sub staple cover

9. Insert the hook (17) of the sub staple cover (B) and turn the cover (B) in the direction of arrow until it clicks to attach.

8. Retirez la vis (15) du côté arrière de la machine pour déposer le capot (16).

Fixation du capot de l'agrafeuse auxiliaire

9. Insérez le crochet (17) du capot de l'agrafeuse auxiliaire (B), puis faites tourner le capot (B) dans le sens de la flèche jusqu'à ce qu'il s'encliquète pour le fixer.

8. Saque el tornillo (15) del lado trasero de la máquina para desmontar la cubierta (16).

Colocación de la cubierta secundaria de grapas

9. Inserte el gancho (17) en la cubierta secundaria de grapas (B) y gire la cubierta (B) en el sentido de la flecha hasta que se produzca un chasquido para colocarlo.

8. Die Schraube (15) auf der Rückseite der Maschine herausdrehen, um die Abdeckung (16) abzunehmen.

Anbringen der Hefterhilfsabdeckung

9. Den Haken (17) der Hefterhilfsabdeckung (B) einsetzen, und die Abdeckung (B) in Pfeilrichtung drehen, bis sie mit einem Klicken einrastet.

8. Togliete la vite (15) dal lato posteriore della macchina per rimuovere il coperchio (16).

Montaggio del coperchio secondario della pinzatrice

9. Inserite il gancio (17) del coperchio secondario della pinzatrice (B) e fate ruotare il coperchio (B) nella direzione della freccia fino a quando non si mette in posizione con un clic.

8. 卸下机器主机后面的1个螺丝(15),取下盖板(16)。

安装副装订器盖板

9. 将副装订器盖板(B)的钩件(17)插入后,朝箭头方向转动安装,直至听到咔叽声为止。

8. 機械本体後側のビス(15)1本を外し、カバー(16)を取り外す。

サブステープルカバーの取り付け

9. サブステープルカバー(B)のフック(17)を挿入し、カチッと音がするまで矢印方向に回転し取り付ける。

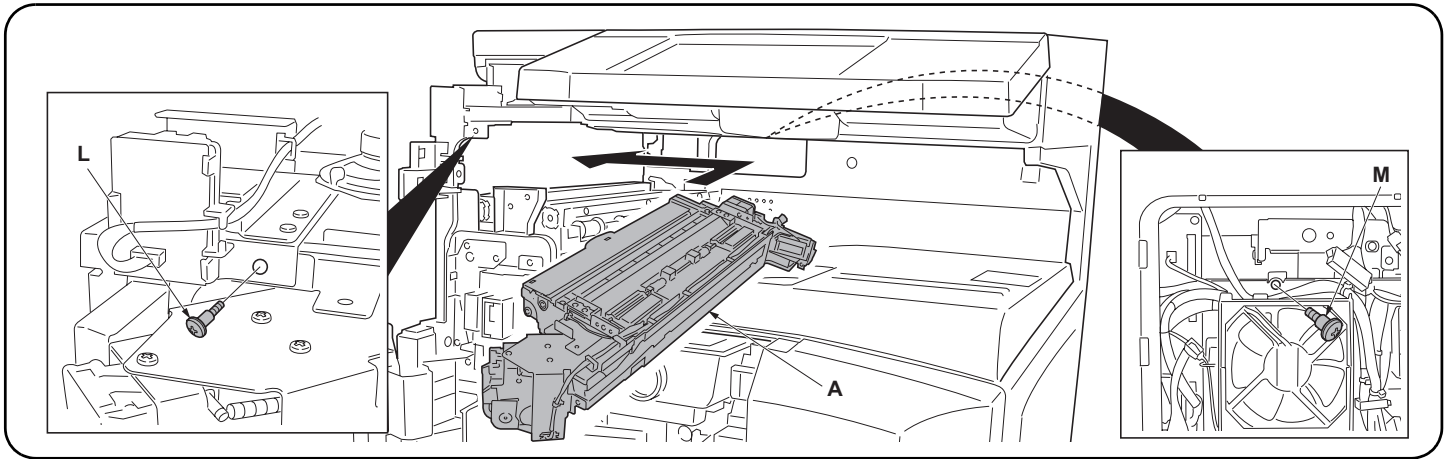

Installing the paper conveying unit

10. Insert the paper conveying unit (A) from the machine front and slide it to the left.
11. Fix the paper conveying unit (A) using two pins.
Front: Use the large pin (L).
Rear: Use the small pin (M).

Installation de l'unité de transport du papier

10. Insérez l'unité de transport du papier (A) depuis l'avant de la machine et faites-le glisser vers la gauche.
11. Fixez l'unité de transport du papier (A) à l'aide de deux goupilles.
Avant: Utilisez la grande goupille (L).
Arrière: Utilisez la petite goupille (M).

Instalación de la unidad de transporte de papel

10. Inserte la unidad de transporte de papel (A) desde el frente de la máquina y deslice hacia la izquierda.
11. Fije la unidad de transporte de papel (A) utilizando dos pasadores.
Frente: Utilice el pasador grande (L).
Atrás: Utilice el pasador pequeño (M).

Installieren der Papierfördereinheit

10. Die Papierfördereinheit (A) von der Vorderseite der Maschine einführen und nach links schieben.
11. Die Papierfördereinheit (A) mit zwei Stiften befestigen.
Vorn: Den großen Stift (L) verwenden.
Hinten: Den kleinen Stift (M) verwenden.

Montaggio dell'unità di trasporto della carta

10. Inserite l'unità di trasporto della carta (A) dal lato anteriore della macchina e fatelo scivolare verso sinistra.
11. Fissate l'unità di trasporto della carta (A) utilizzando due perni.
Lato anteriore: utilizzate il perno grande (L).
Lato posteriore: utilizzate il perno piccolo (M).

安装输送组件

10. 从机器主机前面插入输送组件 (A), 向左侧滑动。
11. 用 2 个卡销固定输送组件 (A)。
前面: 大卡销 (L)
后面: 小卡销 (M)

搬送ユニットの取り付け

10. 搬送ユニット (A) を機械本体前側から挿入し、左側にスライドする。
11. 搬送ユニット (A) をピン 2 本で固定する。
前側: ピン大 (L)
後側: ピン小 (M)

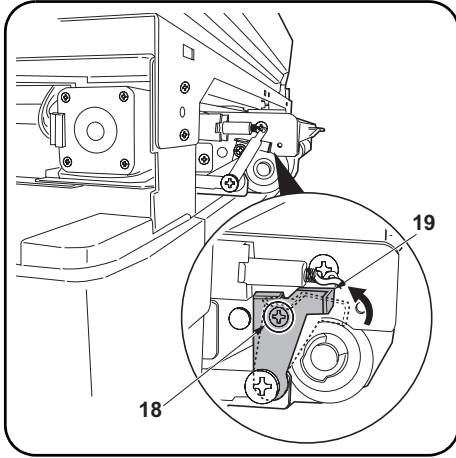

Releasing the lever holding plate

12. Loosen the screw (18) of the paper conveying unit (A) and release the lever holding plate (19) in the direction of arrow.
13. Tighten the screw (18).

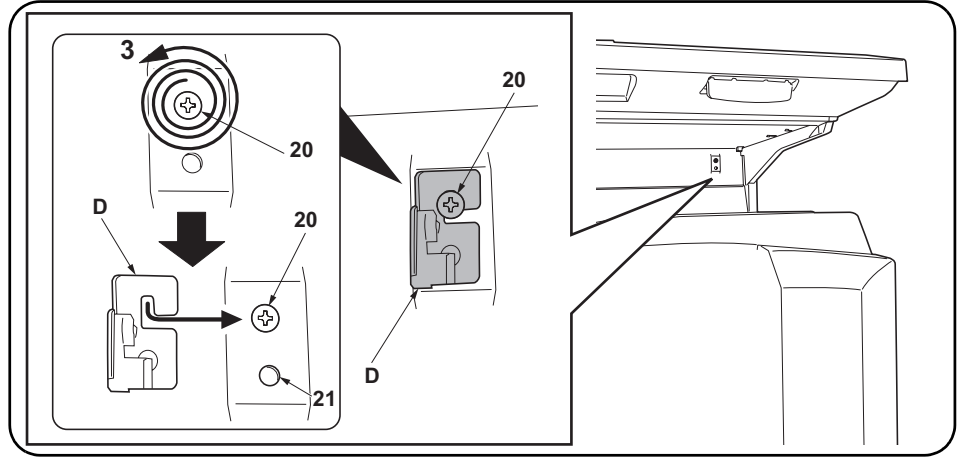

Installing the finisher process table

14. Loosen the screw (20) approx. 3 turns.
Do not turn the screw (20) too far, otherwise it may drop into the machine.
15. Fit the hook holder (D) to the screw (20).
16. Fit the hole of the hook holder (D) to the positioning projection (21) and then tighten the screw (20) to fix the hook holder (D).

Libération de la plaque de support de levier

12. Desserrez la vis (18) de l'unité de transport du papier (A) et libérez la plaque de support de levier (19) dans le sens de la flèche.
13. Resserrez la vis (18).

Installation de la table de processus du module de finition

14. Desserrez la vis (20) d'environ trois tours.
Ne pas tourner la vis (20) excessivement, sinon elle risquerait de tomber dans la machine.
15. Placez le support de crochet (D) sur la vis (20).
16. Faites coïncider l'orifice du support de crochet (D) avec la saillie de positionnement (21), puis serrez la vis (20) pour fixer le support de crochet (D).

Afijado de la placa de soporte de palanca

12. Afloje el tornillo (18) de la unidad de transporte de papel (A) y suelte la placa de soporte de la palanca (19) en el sentido de la flecha.
13. Apriete el tornillo (18).

Instalación de la tabla de proceso de finalizador

14. Afloje el tornillo (20) aprox. 3 giros.
No gire demasiado el tornillo (20) porque puede caerse dentro de la máquina.
15. Encaje el soporte de gancho (D) en el tornillo (20).
16. Encaje el orificio del soporte de gancho (D) en la saliente de proyección (21) y apriete el tornillo (20) para fijar el soporte de gancho (D).

Freigeben der Hebelhalteplatte

12. Die Schraube (18) der Papierfördereinheit (A) lösen, und die Hebelhalteplatte (19) in Pfeilrichtung freigeben.
13. Die Schraube (18) festziehen.

Installieren der Finisher-Druckablage

14. Die Schraube (20) um etwa 3 Umdrehungen lösen.
Die Schraube (20) nicht zu weit lösen, weil sie sonst in die Maschine fallen kann.
15. Den Hakenhalter (D) an der Schraube (20) anbringen.
16. Das Loch des Hakenhalters (D) auf den Positioniersprung (21) ausrichten, und dann die Schraube (20) zur Befestigung des Hakenhalters (D) festziehen.

Rilascio della leva che fissa la piastra

12. Allentate la vite (18) dell'unità di trasporto della carta (A) e rilasciate la leva che fissa la piastra (19) nella direzione della freccia.
13. Stringete la vite (18).

Installazione del tabella di elaborazione del finitore.

14. Allentate di 3 giri circa la vite (20).
Non girate troppo la vite (20), altrimenti potrebbe cadere nella macchina.
15. Montate il supporto a gancio (D) sulla vite (20).
16. Montate il foro del supporto a gancio (D) sulla posizione (21) e poi stringete la vite (20) per fissare il supporto a gancio (D).

松解固定金属柄

12. 松弛输送组件 (A) の 1 个螺丝 (18), 朝箭头方向松解固定金属柄 (19)。
13. 然后, 紧固 1 个螺丝 (18)。

安装装订分页器处理托盘

14. 螺丝 1 个 (20) (约 3 圈)。
不可过度松弛 1 个螺丝 (20), 否则会导致螺丝掉落机器内部。
15. 将钩夹 (D) 插入 1 个螺丝 (20)。
16. 将定位突起部 (21) 对准钩夹 (D) 孔的位置, 用 1 个螺丝 (20) 紧固。

レバー固定金具の解除

12. 搬送ユニット (A) のビス (18) 1 本をゆるめ、レバー固定金具 (19) を矢印方向に解除する。
13. ビス (18) 1 本を締める。

フィニッシャ処理トレイの取り付け

14. ビス (20) 1 本を緩める (約 3 回転)。
ビス (20) 1 本を緩めすぎると、機械内部に落下する恐れがある。
15. フックホルダ (D) をビス (20) 1 本に挿入する。
16. 位置決め突起 (21) とフックホルダ (D) の穴の位置を合わせて、ビス (20) 1 本を締めて固定する。

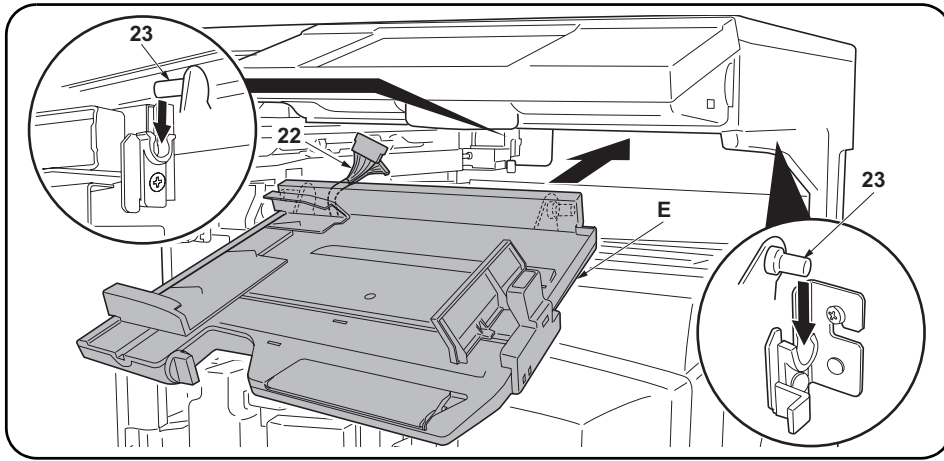

17. Extend the wires of connectors (22) of the finisher process table (E) straight.
18. Insert the finisher process table (E) from the front side of the machine and hang the hooks (23) on the right and left of the table (E) onto the machine.
Pass the connectors of the finisher process table (E) through the opening at the rear side of the machine.

17. Allongez tout droit les fils des connecteurs (22) de la table de processus du module de finition (E).
18. Insérez la table de processus du module de finition (E) depuis l'avant de la machine, et suspendez sur la machine les crochets (23) se trouvant sur les côtés droit et gauche du plateau (E).
Faire passer les connecteurs de la table de processus du module de finition (E) par l'ouverture du côté arrière de la machine.

17. Alargue los cables de los conectores (22) de la tabla de proceso de finalizador (E) para que queden extendidos.
18. Inserte la tabla de proceso de finalizador (E) por el lado delantero de la máquina y cuelgue los ganchos (23) en los lados derecho e izquierdo de la tabla (E) de la máquina.
Pase los conectores de la tabla de proceso de finalizador (E) por la abertura en el lado trasero de la máquina.

17. Die Kabel der Steckverbinder (22) der Finisher-Druckablage (E) gerade ziehen.
18. Die Finisher-Druckablage (E) von der Vorderseite der Maschine einführen, und die Haken (23) auf der rechten und linken Seite der Ablage (E) in die Maschine einhängen.
Die Steckverbinder der Finisher-Druckablage (E) durch die Öffnung auf der Rückseite der Maschine führen.

17. Allungate i cavi dei connettori (22) del tabella di elaborazione del finitore (E).
18. Inserite la tabella di elaborazione del finitore (E) dal lato anteriore della macchina e appendete i ganci (23) a destra e a sinistra del tabella (E) sulla macchina.
Fate passare i connettori della tabella di elaborazione del finitore (E) attraverso l'apertura sul lato posteriore della macchina.

17. 将装订分页器处理托盘 (E) 插头的电线 (22) 伸直。
18. 从机器主机前面插入装订分页器处理托盘 (E)，挂在左右钩件 (23) 上。
将装订分页器处理托盘 (E) 的插头通过机器主机后面的开口部。

17. フィニッシャ処理トレイ (E) のコネクタ電線 (22) をまっすぐに伸ばす。
18. フィニッシャ処理トレイ (E) を機械本体前側から挿入し、左右のフック (23) を引っ掛ける。
フィニッシャ処理トレイ (E) のコネクタを機械本体後側の開口部に通す。

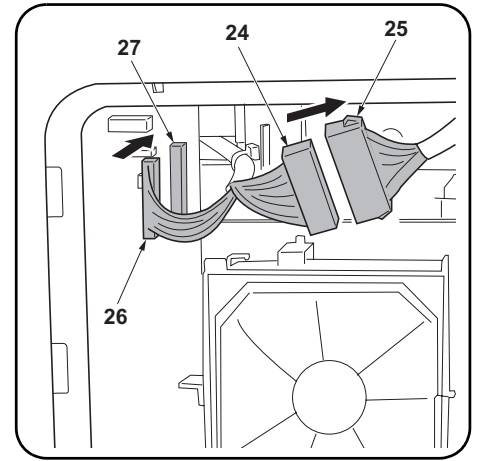

19. At the rear side of the machine, connect the connector (24) of the finisher process table to the connector (25) of the paper conveying unit.
20. Connect the connector (26) of the finisher process table to YC4 (27) on the engine PWB.
21. Replace the cover (16) using the screw (15) removed in step 8.

19. Sur le côté arrière de la machine, branchez le connecteur (24) de la table de processus du module de finition au connecteur (25) de l'unité de transport du papier.
20. Branchez le connecteur (26) de la table de processus du module de finition à YC4 (27) sur le PWB du moteur.
21. Remettez le capot (16) en place en utilisant la vis (15) retirée auparavant lors de l'étape 8.

19. En el lado trasero de la máquina, conecte el conector (24) de la tabla de proceso de finalizador en el conector (25) de la unidad de transporte de papel.
20. Conecte el conector (26) de la tabla de proceso de finalizador en YC4 (27) en el PWB del motor.
21. Vuelva a colocar la cubierta (16) utilizando el tornillo (15) sacado en el paso 8.

19. Den Steckverbinder (24) der Finisher-Druckablage auf der Rückseite der Maschine mit dem Steckverbinder (25) der Papierfördereinheit verbinden.
20. Den Steckverbinder (26) der Finisher-Druckablage an YC4 (27) der Motorplatine anschließen.
21. Die Abdeckung (16) wieder mit der in Schritt 8 entfernten Schraube (15) anbringen.

19. Sul lato posteriore della macchina, collegate il connettore (24) della tabella di elaborazione del finitore al connettore (25) dell'unità di trasporto della carta.
20. Collegate il connettore (26) della tabella di elaborazione del finitore al YC4 (27) sul motore PWB.
21. Rimettete a posto il coperchio (16) utilizzando la vite (15) rimossa nel passo 8.

19. 绕到机器主机后面，将装订分页器处理托盘的插头 (24) 连接在输送组件的插头 (25) 上。
20. 将装订分页器处理托盘的插头 (26) 连接在引擎主板的 YC4 (27) 上。
21. 在步骤 8 拆下的盖板 (16)，用 1 个螺丝 (15) 按原样装好。

19. 機械本体後側にまわり、フィニッシャ処理トレイのコネクタ (24) を搬送ユニットのコネクタ (25) に接続する。
20. フィニッシャ処理トレイのコネクタ (26) をエンジン回路基板の YC4 (27) に接続する。
21. 手順 8 で取り外したカバー (16) をビス (15) 1 本で元通り取り付けする。

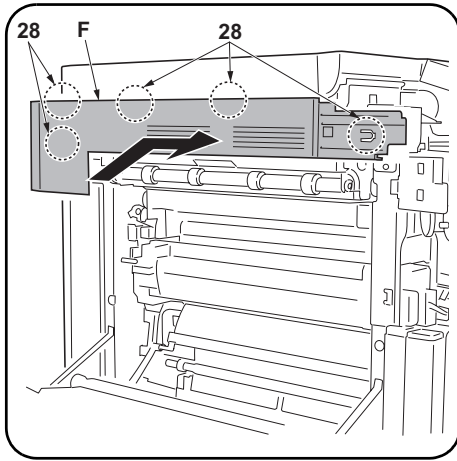

Attaching the upper left cover

22. Insert five catches (28) to attach the upper left cover (F).

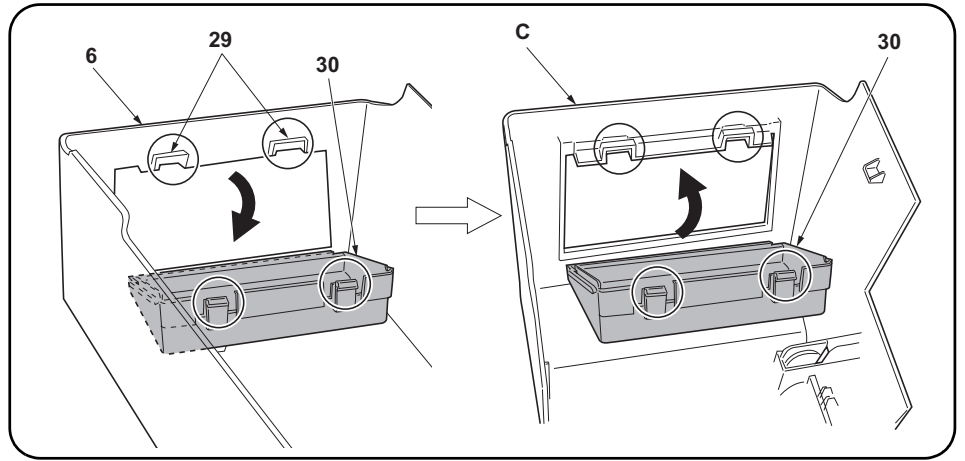

Installing the staple cover

23. Release two latches (29) of the cover (6) removed in step 3 using a flat-head screwdriver to remove the lower clip holder (30).

24. Attach the lower clip holder (30) to the staple cover (C).

Fixation du capot supérieur gauche

22. Insérez les cinq fermetoirs (28) pour fixer le capot supérieur gauche (F).

Installation du capot de l'agrafeuse

23. Libérez les deux verrous (29) du capot (6) retiré auparavant lors de l'étape 3 en utilisant un tournevis à tête plate pour retirer le support de pince inférieur (30).

24. Fixez le support de pince inférieur (30) sur le capot de l'agrafeuse (C).

Colocación de la cubierta superior izquierda

22. Inserte las uñas (28) para instalar la cubierta superior izquierda (F).

Instalación de la cubierta de grapas

23. Suelte los dos pestillos (29) de la cubierta (6) desmontada en el paso 3 utilizando el destornillador de punta plana para desmontar el soporte de clip inferior (30).

24. Coloque el soporte de clip inferior (30) en la cubierta de grapas (C).

Anbringen der oberen linken Abdeckung

22. Die fünf Klauen (28) zur Anbringung der oberen linken Abdeckung (F) einhängen.

Installieren der Hefterabdeckung

23. Die zwei Rasten (29) der in Schritt 3 entfernten Abdeckung (6) mit einem Flachsraubenzieher lösen, um den unteren Büroklammerhalter (30) abzunehmen.

24. Den unteren Büroklammerhalter (30) an der Hefterabdeckung (C) anbringen.

Montaggio del coperchio superiore sinistro

22. Inserite cinque ganci (28) per fissare il coperchio superiore sinistro (F).

Installazione del coperchio della pinzatrice

23. Rilasciate due fermi (29) del coperchio (6) rimosso nel passo 3 utilizzando un giravite a punta piatta per rimuovere il contenitore inferiore delle graffette (30).

24. Montate il contenitore inferiore delle graffette (30) al coperchio della pinzatrice (C).

安装左上盖板

22. 将 5 处钩件 (28) 插入后, 装上左上盖板 (F)。

安装装订器盖板

23. 用一字形螺丝刀等松解在步骤 3 卸下的盖板 (6) 的 2 处嵌入板 (29), 并取下夹子盒下 (30)。

24. 将夹子盒下 (30) 装在装订器盖板 (C) 上。

左上カバーの取り付け

22. 引っ掛け (28) 5 箇所を挿入し、左上カバー (F) を取り付ける。

ステーブルカバーの取り付け

23. 手順 3 で取り外したカバー (6) のはめ込み (29) 2 箇所をマイナスドライバーなどで解除し、クリップ入れ下 (30) を取り外す。

24. クリップ入れ下 (30) をステーブルカバー (C) に取り付ける。

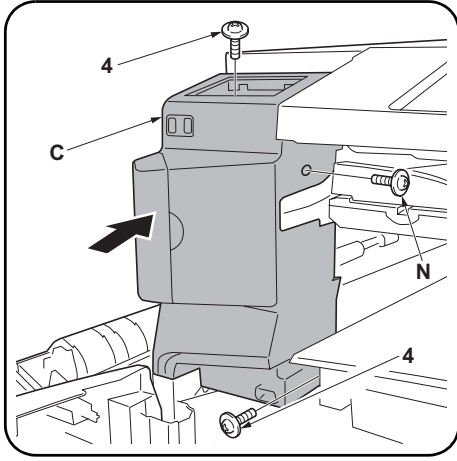

25. Fix the staple cover (C) using three screws.
Upper/Lower right: Use two screws (4) removed in step 3.
Upper right: Use M3 × 6 screw (N).

26. Replace the clip holder (3) removed in step 2.
27. Close left cover 1 (2) and the front cover (1).

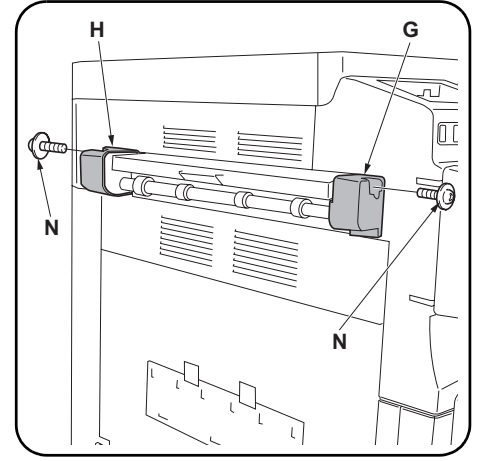

Attaching the finisher tray
28. Fix the front eject cover (G) and the rear eject cover (H) using an M3 × 6 screw (N) each.

25. Fixez le capot de l'agrafeuse (C) à l'aide de trois vis.
Côté supérieur/inférieur droit: Utilisez les deux vis (4) retirées auparavant lors de l'étape 3.
Côté supérieur droit: Utilisez une vis M3 × 6 (N).

26. Remettez en place le support à pince (3) retiré auparavant lors de l'étape 2.
27. Refermez le capot gauche 1 (2) et le capot avant (1).

Fixation du plateau du module de finition
28. Fixez le capot d'éjection avant (G) et le capot d'éjection arrière (H) à l'aide d'une vis M3 × 6 (N) pour chaque capot.

25. Fije la cubierta de grapas (C) utilizando tres tornillos.
Superior/inferior derecho: Utilice dos tornillos (4) sacados en el paso 3.
Superior derecho: Utilice el tornillo M3 × 6 (N).

26. Vuelva a colocar el soporte de clip (3) desmontado en el paso 2.
27. Cierre la cubierta izquierda 1 (2) y la cubierta frontal (1).

Colocación de la bandeja de finalizador
28. Fije la cubierta de expulsión frontal (G) y la cubierta de expulsión trasera (H) utilizando un tornillo M3 × 6 (N) en cada lugar.

25. Die Hefterabdeckung (C) mit drei Schrauben befestigen.
Oben/Unten rechts: Die in Schritt 3 entfernten zwei Schrauben (4) benutzen.
Oben rechts: Die M3 × 6 Schraube (N) benutzen.

26. Den in Schritt 2 entfernten Büroklammerhalter (3) wieder anbringen.
27. Die linke Abdeckung 1 (2) und die Frontabdeckung (1) schließen.

Anbringen der Finisher-Ablage
28. Die Frontauswurfabdeckung (G) und die Rückauswurfabdeckung (H) mit je einer M3 × 6 Schraube (N) befestigen.

25. Fissate il coperchio della pinzatrice (C) utilizzando tre viti.
Lato superiore/inferiore destro: utilizzate due viti (4) rimosse nel passo 3.
Lato superiore destro: utilizzate una vite M3 × 6 (N).

26. Rimettete al suo posto il contenitore delle graffette (3) rimosso nel passo 2.
27. Chiudete il coperchio sinistro 1 (2) e il coperchio anteriore (1).

Montaggio del vassoio del finitore
28. Fissate il coperchio anteriore di espulsione carta (G) e il coperchio posteriore di espulsione carta (H) utilizzando una vite M3 × 6 (N) per ciascuno.

25. 用3个螺丝固定装订器盖板(C)。
上侧、右下侧:在步骤3拆下的2个螺丝(4)
右上侧:1个螺丝M3×6(N)

26. 在步骤2拆下的夹子盒(3)按原样装好。
27. 关闭左盖板1(2)和前盖板(1)。

安装装订分页器托盘
28. 用各1个螺丝M3×6(N)固定排纸盖板前(G)和后(H)。

25. ビス3本でステーブルカバー(C)を固定する。
上側・右下側:手順3で外したビス(4)2本
右上側:ビスM3×6(N)1本

26. 手順2で取り外したクリップ入れ(3)を元通り取り付ける。
27. 左カバー1(2)および前カバー(1)を閉じる。

フィニッシュトレイの取り付け
28. ビスM3×6(N)各1本で排出カバー前(G)および後(H)を固定する。

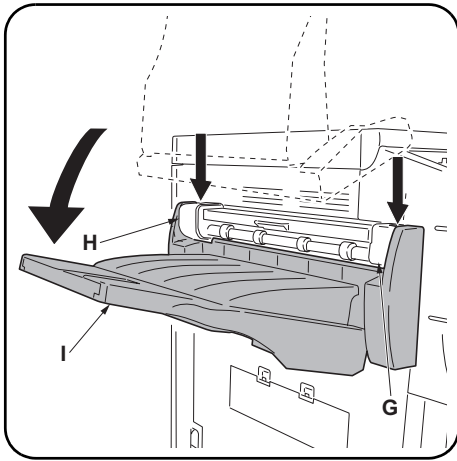

29. Insert the front and rear hooks of the finisher tray (I) into the front eject cover (G) and the rear eject cover (H) respectively and then attach the finisher tray (I).

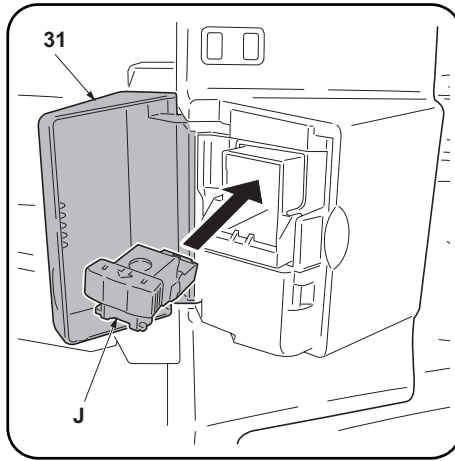

Attaching the staple cartridge
30. Open the cover (31) and insert the staple cartridge (J).
31. Close the cover (31).

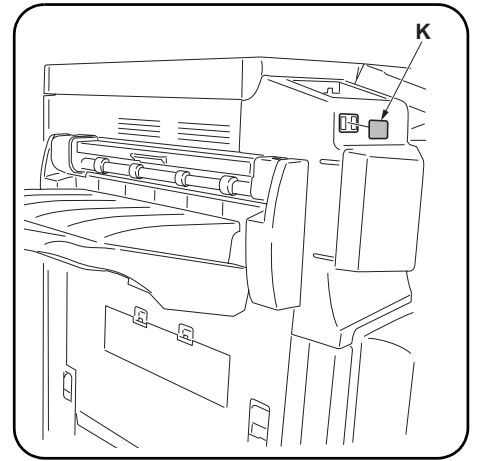

Adhering the blindfold seal (For models with monochrome touch panel only)
32. Clean the staple cover with alcohol and then adhere the blindfold seal (K).

29. Insérez les crochets avant et arrière du plateau du module de finition (I) dans le capot d'éjection avant (G) et dans le capot d'éjection arrière (H) respectivement, puis fixez le plateau du module de finition (I).

Fixation de la cartouche d'agrafes
30. Ouvrez le capot (31) et insérez la cartouche d'agrafes (J).
31. Refermez le capot (31).

Collage de l'étiquette de masquage (pour les modèles équipés d'un écran tactile monochrome seulement)
32. Nettoyez le capot de l'agrafeuse avec de l'alcool, puis collez l'étiquette de masquage (K).

29. Inserte los ganchos delantero y trasero de la bandeja de finalizador (I) en la cubierta de expulsión frontal (G) y la cubierta de expulsión trasera (H) respectivamente y coloque la bandeja de finalizador (I).

Colocación del cartucho de grapas
30. Abra la cubierta (31) e inserte el cartucho de grapas (J).
31. Cierre la cubierta (31).

Pegado del sello ciego (Sólo modelos con panel de toque monocromático)
32. Limpie la cubierta de grapas con alcohol y pegue el sello ciego (K).

29. Die vorderen und hinteren Haken der Finisher-Ablage (I) jeweils in die Frontauswurfabdeckung (G) und die Rückauswurfabdeckung (H) einführen, und dann die Finisher-Ablage (I) anbringen.

Anbringen des Heftklammermagazins
30. Die Abdeckung (31) öffnen, und das Heftklammermagazin (J) einsetzen.
31. Die Abdeckung (31) schließen.

Anbringen des Blindaufklebers (nur für Modelle mit Monochrom-Sensorbildschirm)
32. Die Hefterabdeckung mit Alkohol reinigen, und dann den Blindaufkleber (K) anbringen.

29. Inserite i ganci anteriori e posteriori del vassoio del finitore (I) rispettivamente nel coperchio anteriore di espulsione carta (G) e nel coperchio posteriore di espulsione carta (H) e poi montate il vassoio del finitore (I).

Montaggio della cartuccia dei punti metallici
30. Aprite il coperchio (31) e inserite la cartuccia dei punti metallici (J).
31. Chiudete il coperchio (31).

Applicate il sigillo mascherina (solo per i modelli con pannello monocromatico a sfioramento)
32. Pulite il coperchio della pinzatrice con alcol e poi applicate il sigillo mascherina (K).

29. 将装订分页器托盘 (I) 的构件插入排纸盖板前 (G) 和后 (H), 然后装上装订分页器托盘 (I)。

安装订书钉盒
30. 打开盖板 (31) 后, 插入订书钉盒 (J)。
31. 关闭盖板 (31)。

贴上标贴
(只限单色触控式面板机)
32. 用酒精清洁后, 贴上标贴 (K)。

29. フィニッシュャトレイ (I) のフックを排出カバー前 (G) および後 (H) に挿入し、フィニッシュャトレイ (I) を取り付ける。

ステーブルカートリッジの取り付け
30. カバー (31) を開き、ステーブルカートリッジ (J) を挿入する。
31. カバー (31) を閉じる。

シールの貼り付け
(モノクロタッチパネル機のみ)
32. アルコール清掃後、シール (K) を貼り付ける。

Checking the operation

1. Connect the power plug of the machine to the wall outlet and turn the main power switch on.
2. Make a proof copy in the staple mode to check the finishing and stapling.

Vérification du fonctionnement

1. Insérer la fiche d'alimentation de la machine dans la prise murale et mettre la machine sous tension.
2. Effectuez une copie de test en mode d'agrafage pour vérifier la finition et l'agrafage.

Verificación del funcionamiento

1. Conecte el enchufe eléctrico de la máquina en un tomacorriente de la pared y conecte el interruptor principal.
2. Haga una copia de prueba en el modo de grapas para verificar el finalizado y grapado.

Überprüfen des Betriebs

1. Den Netzstecker der Maschine in die Steckdose stecken und den Betriebsschalter einschalten.
2. Eine Probekopie im Heftermodus anfertigen, um die Verarbeitung und Heftung zu überprüfen.

Verifica di funzionamento

1. Collegare la spina del cavo di alimentazione della macchina alla presa a muro della rete elettrica e accendere l'interruttore principale di alimentazione.
2. Nel modo graffatrice eseguite una copia di prova per verificare la cucitura e la rifinitura.

操作确认

1. 将机器主机上的电源插头插入插座中，打开主电源开关。
2. 选择装订复印模式，确认装订分页器和装订器的操作状况。

動作確認

1. 機械本体の電源プラグをコンセントに差し込み、主電源スイッチをONにする。
2. ステープルコピーをおこない、フィニッシャーおよびステープル動作を確認する。

INSTALLATION GUIDE FOR JOB SEPARATOR

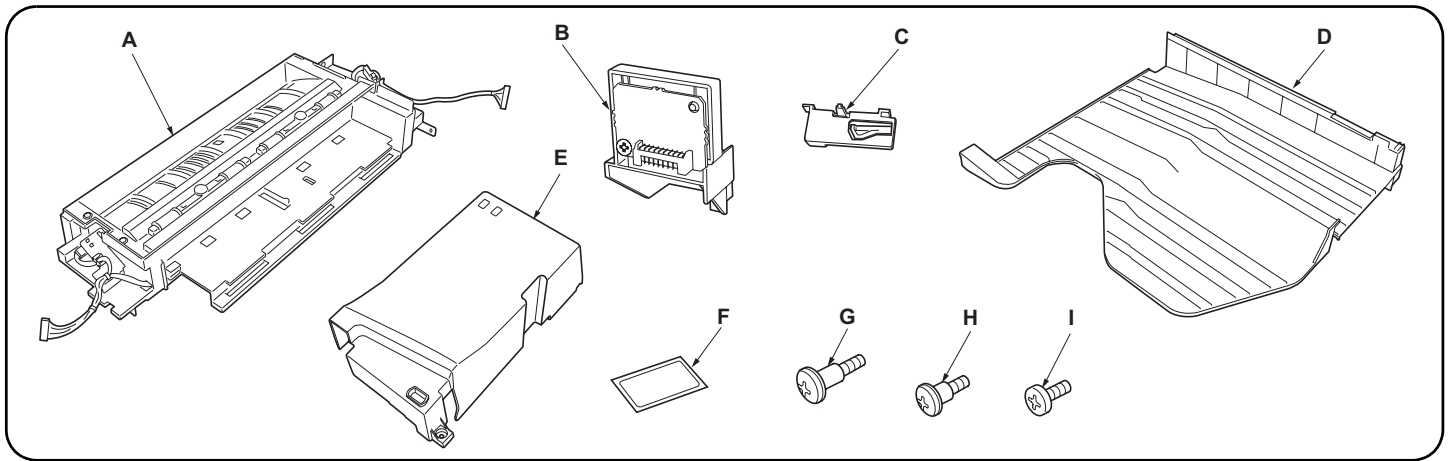

English

Supplied parts

A	Job separator	1
B	LED PWB unit	1
C	Tray holder	1
D	Job separator tray	1
E	Left front cover	1

F	Blindfold seal	1
G	Large pin	1
H	Small pin	1
I	M3 x 6 screw	1

Français

Pièces fournies

A	Séparateur de travaux	1
B	Unité LED PWB	1
C	Support de plateau	1
D	Plateau du séparateur de travaux	1
E	Capot avant gauche	1

F	Étiquette de masquage	1
G	Grande goupille	1
H	Petite goupille	1
I	Vis M3 x 6	1

Español

Partes suministradas

A	Separador de trabajos	1
B	Unidad PWB LED	1
C	Soporte de bandeja	1
D	Bandeja de separador de trabajos	1
E	Cubierta delantera izquierda	1

F	Sello ciego	1
G	Pasador grande	1
H	Pasador pequeño	1
I	Tornillo M3 x 6	1

Deutsch

Gelieferte Teile

A	Job-Separator	1
B	LED-Platineneinheit	1
C	Fachhalter	1
D	Job-Separator-Fach	1
E	Linke Frontabdeckung	1

F	Blindaufkleber	1
G	Großer Stift	1
H	Kleiner Stift	1
I	M3 x 6 Schraube	1

Italiano

Parti di fornitura

A	Separatore lavori	1
B	Unità LED PWB	1
C	Supporto vassoio	1
D	Vassoio del separatore lavori	1
E	Coperchio frontale sinistro	1

F	Sigillo mascherina	1
G	Perno grande	1
H	Perno piccolo	1
I	Vite M3 x 6	1

简体中文

同装品

A	作业分离器	1
B	LED 电路板组件	1
C	托盘座	1
D	作业分离器托盘	1

E	左前盖板	1
F	标贴	1
G	大卡销	1
H	小卡销	1
I	螺丝 M3 x 6	1

日本語

同梱品

A	ジョブセパレータ	1
B	LED 基板ユニット	1
C	トレイホルダ	1
D	ジョブセパレータトレイ	1

E	左前カバー	1
F	シール	1
G	ピン大	1
H	ピン小	1
I	ビス M3 x 6	1

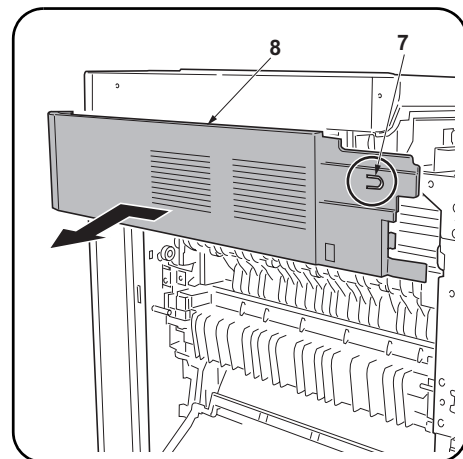
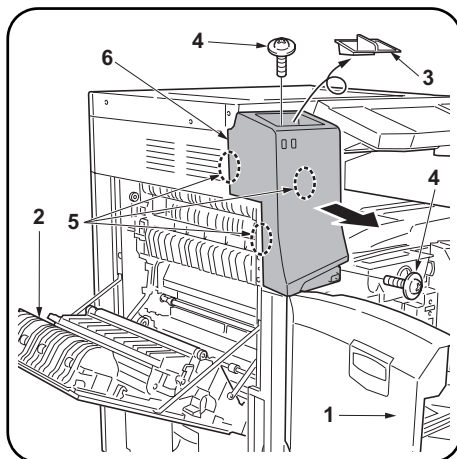

Precautions

- Be sure to remove any tape and/or cushioning material from supplied parts.
- Before installing the job separator, be sure to turn the main power switch of the machine off and unplug the power cable from the wall outlet.

Procedure

Removing the covers

1. Open the front cover (1) and left cover 1 (2).
2. Remove the clip holder (3).
3. Remove two screws (4) and release three latches (5) to remove the cover (6).

4. Release the latch (7) using a flat-head screwdriver to remove the cover (8).

Précautions

- Veillez à retirer les morceaux de bande adhésive et/ou les matériaux de rembourrage des pièces fournies.
- Avant d'installer le séparateur de travaux, veillez à mettre la machine hors tension et à débrancher le câble d'alimentation de la prise murale.

Procédure

Retrait des capots

1. Ouvrez le capot avant (1) et le capot gauche 1 (2).
2. Retirez le support à pince (3).
3. Retirez deux vis (4) et libérez trois verrous (5) pour retirer le capot (6).

4. Libérez le verrou (7) à l'aide d'un tournevis à tête plate pour retirer le capot (8).

Precauciones

- Asegúrese de despegar todas las cintas y/o material amortiguador de las partes suministradas.
- Antes de instalar el separador de trabajos, asegúrese de desconectar el interruptor principal de la máquina y desenchufar el cable eléctrico del tomacorriente de la pared.

Procedimiento

Desmontaje de las cubiertas

1. Abra la cubierta frontal (1) y la cubierta izquierda 1 (2).
2. Desmonte el soporte de clip (3).
3. Saque los dos tornillos (4) y suelte los tres pestillos (5) para desmontar la cubierta (6).

4. Suelte el pestillo (7) utilizando un destornillador de cabeza plana para desmontar la cubierta (8).

Vorsichtsmaßnahmen

- Entfernen Sie Klebeband und/oder Dämpfungsmaterial vollständig von den mitgelieferten Teilen.
- Schalten Sie unbedingt den Betriebsschalter der Maschine aus, und trennen Sie das Netzkabel von der Netzsteckdose, bevor Sie den Job-Separator installieren.

Verfahren

Entfernen der Abdeckungen

1. Die Frontabdeckung (1) und die linke Abdeckung 1 (2) öffnen.
2. Den Büroklammerhalter (3) entfernen.
3. Die zwei Schrauben (4) herausdrehen, und die drei Rasten (5) lösen, um die Abdeckung (6) abzunehmen.

4. Die Raste (7) mit einem Flachsraubenzieher lösen, um die Abdeckung (8) abzunehmen.

Precauzioni

- Accertarsi di rimuovere tutti i nastri adesivi e/ o il materiale di imbottitura dalle parti fornite.
- Prima di installare il separatore lavori, assicurarsi di spegnere l'interruttore principale di alimentazione della macchina e scollegare la spina del cavo di alimentazione dalla presa a muro della rete elettrica.

Procedura

Rimozione dei coperchi

1. Aprite il coperchio anteriore (1) e il coperchio sinistro 1 (2).
2. Rimuovete il contenitore delle graffette (3).
3. Togliete due viti (4) e rilasciate i tre fermi (5) per rimuovere il coperchio (6).

4. Rilasciate il fermo (7) utilizzando un giravite a punta piatta per rimuovere il coperchio (8).

注意事項

- 如果同裝品上帶有固定膠帶、緩衝材料時務必揭下。
- 安裝分離器時，必須先關閉機器主機的主電源開關，並拔下電源插頭後，再進行安裝作業。

安裝步驟

拆下蓋板類

1. 打開前蓋板 (1) 和左蓋板 1 (2)。
2. 拆下夾子盒 (3)。
3. 卸下 2 個螺絲 (4)，鬆解 3 處嵌入板 (5)，然後，取下蓋板 (6)。

4. 用一字形螺絲刀等鬆解嵌入板 (7)，取下蓋板 (8)。

注意事項

- 同梱品に固定テープ、緩衝材が付いている場合は必ず取り外すこと。
- ジョブセパレータを設置する場合は、機械本体の主電源スイッチを OFF にし、電源プラグを抜いてから作業をおこなう。

設置手順

カバー類の取り外し

1. 前カバー (1) および左カバー 1 (2) を開く。
2. クリップ入れ (3) を取り外す。
3. ビス (4) 2 本を外し、はめ込み (5) 3 箇所を解除してカバー (6) を取り外す。

4. はめ込み (7) をマイナスドライバーなどで解除し、カバー (8) を取り外す。

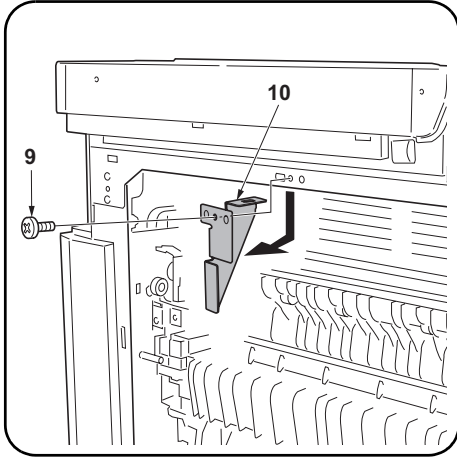

5. Remove the screw (9) to remove the metal plate (10). The removed metal plate (10) is no longer required.

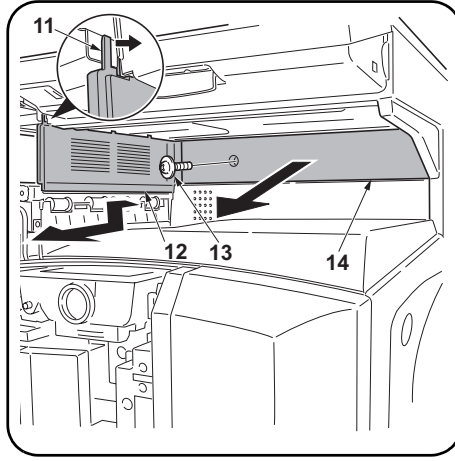

6. Release the latch (11) using a flat-head screwdriver and slide the cover (12) to the front to remove.
7. Remove the screw (13) to remove the cover (14).

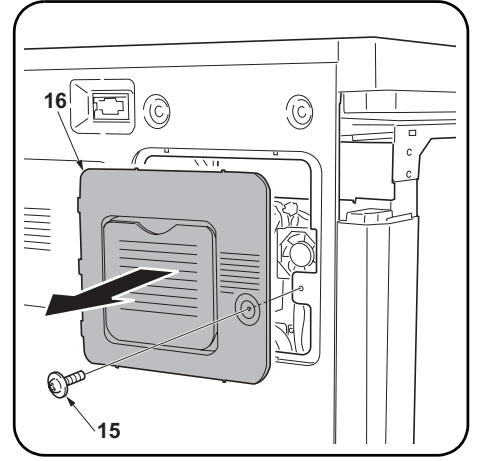

8. Remove the screw (15) from the rear side of the machine to remove the cover (16).

5. Retirez la vis (9) pour déposer la plaque métallique (10). La plaque métallique déposée (10) n'est plus nécessaire.

6. Libérez le verrou (11) à l'aide d'un tournevis à tête plate, puis faites glisser le capot (12) vers l'avant pour le déposer.
7. Retirez la vis (13) pour déposer le capot (14).

8. Retirez la vis (15) du côté arrière de la machine pour déposer le capot (16).

5. Quite el tornillo (9) para desmontar la placa de metal (10). La placa de metal desmontada (10) ya no es necesaria.

6. Suelte el pestillo (11) utilizando un destornillador de cabeza plana y deslice la cubierta (12) hacia delante para desmontarla.
7. Saque el tornillo (13) para desmontar la cubierta (14).

8. Saque el tornillo (15) del lado trasero de la máquina para desmontar la cubierta (16).

5. Die Schraube (9) herausdrehen, um die Metallplatte (10) abzunehmen. Die abgenommene Metallplatte (10) wird nicht mehr benötigt.

6. Die Raste (11) mit einem Flachschaubenzieher lösen, und die Abdeckung (12) nach vorn schieben, um sie abzunehmen.
7. Die Schraube (13) herausdrehen, um die Abdeckung (14) abzunehmen.

8. Die Schraube (15) auf der Rückseite der Maschine herausdrehen, um die Abdeckung (16) abzunehmen.

5. Rimuovere la vite (9) per togliere la piastra di metallo (10). La piastra di metallo (10) rimossa non è più necessaria.

6. Rilasciate il fermo (11) utilizzando un giravite a punta piatta e fate scivolare il coperchio (12) verso il lato anteriore per rimuoverlo.
7. Togliete la vite (13) per rimuovere il coperchio (14).

8. Togliete la vite (15) dal lato posteriore della macchina per rimuovere il coperchio (16).

5. 卸下 1 个螺丝 (9), 取下金属件 (10)。不安装金属件 (10)。

6. 用一字形螺丝刀等松解嵌入板 (11), 将盖板 (12) 向跟前拉并取下。
7. 卸下 1 个螺丝 (13), 取下盖板 (14)。

8. 卸下机器主机后面的 1 个螺丝 (15), 取下盖板 (16)。

5. ビス (9) 1 本を外し、金具 (10) を取り外す。金具 (10) は取り付けない。

6. はめ込み (11) をマイナスドライバーなどで解除し、カバー (12) を手前側に引いて取り外す。
7. ビス (13) 1 本を外し、カバー (14) を取り外す。

8. 機械本体後側のビス (15) 1 本を外し、カバー (16) を取り外す。

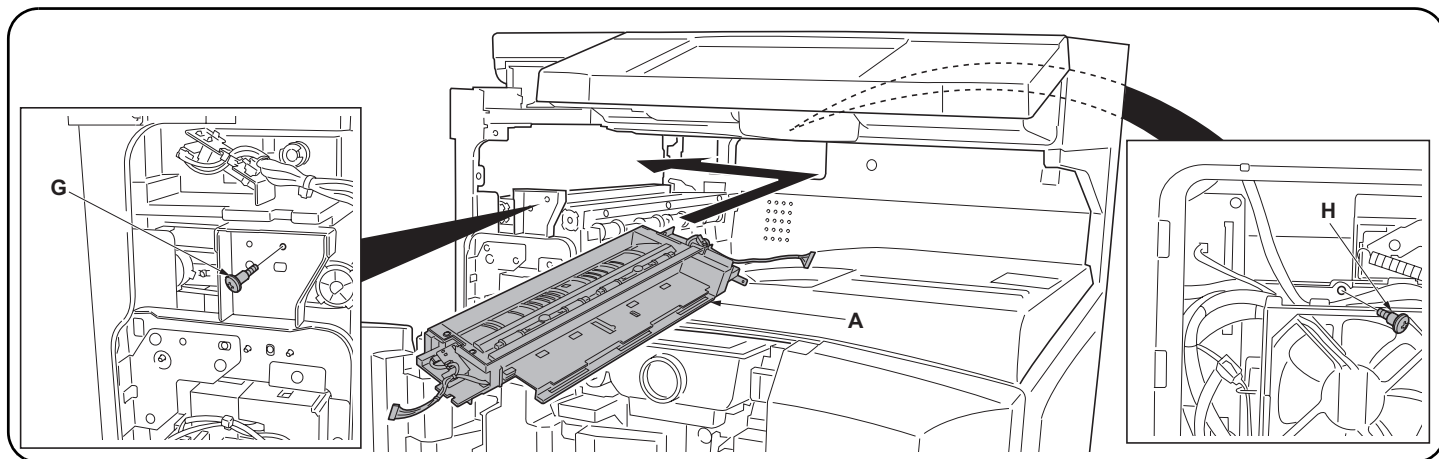

Installing the job separator

9. Insert the job separator (A) from the machine front and slide it to the left.
10. Fix the job separator (A) using two pins.
Front: Use the large pin (G).
Rear: Use the small pin (H).

Installation du séparateur de travaux

9. Insérez le séparateur de travaux (A) depuis l'avant de la machine et faites-le glisser vers la gauche.
10. Fixez le séparateur de travaux (A) à l'aide de deux goupilles.
Avant: Utilisez la grande goupille (G).
Arrière: Utilisez la petite goupille (H).

Instalación del separador de trabajos

9. Inserte el separador de trabajos (A) en el frente de la máquina y deslícelo a la izquierda.
10. Fije el separador de trabajo (A) utilizando dos pasadores.
Frente: Utilice el pasador grande (G).
Atrás: Utilice el pasador pequeño (H).

Installieren des Job-Separators

9. Den Job-Separator (A) von der Vorderseite der Maschine einführen und nach links schieben.
10. Den Job-Separator (A) mit zwei Stiften befestigen.
Vorn: Den großen Stift (G) verwenden.
Hinten: Den kleinen Stift (H) verwenden.

Installazione del separatore lavori

9. Inserire il separatore lavori (A) dal lato frontale della macchina e farlo scorrere a sinistra.
10. Fissare il separatore lavori (A) utilizzando due perni.
Lato frontale: utilizzare il perno grande (G).
Lato posteriore: utilizzare il perno piccolo (H).

安装作业分离器

9. 从机器主机前面插入作业分离器 (A)，向左侧滑动。
10. 用 2 个卡销固定作业分离器 (A)。
前面：大卡销 (G)
后面：小卡销 (H)

ジョブセパレータの取り付け

9. ジョブセパレータ (A) を機械本体前側から挿入し、左側にスライドする。
10. ジョブセパレータ (A) をピン 2 本で固定する。
前側: ピン大 (G)
後側: ピン小 (H)

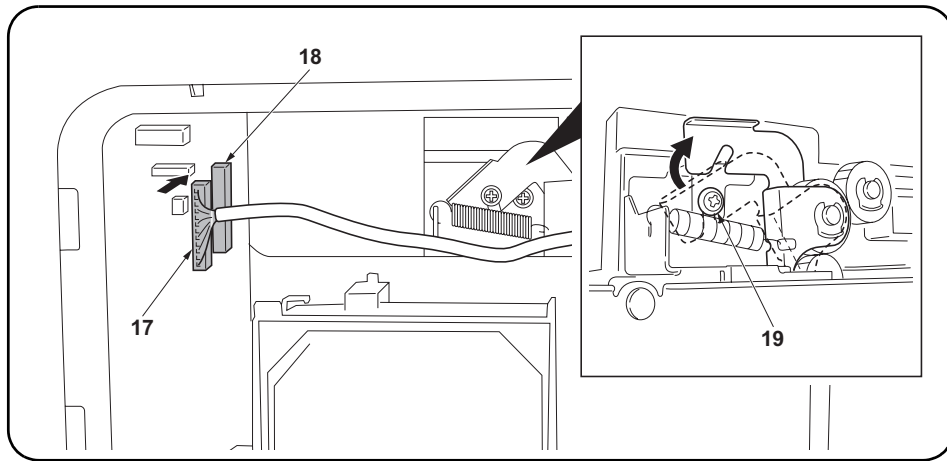

11. Connect the connector (17) at the rear of the job separator to YC4 (18) on the engine PWB.
12. Loosen the screw (19) to make the drive unit of the job separator ready for starting to drive.
13. Tighten the screw (19).
14. Refit the cover (16) using the screw (15) removed in step 8.

-
11. Branchez le connecteur (17) situé à l'arrière du séparateur de travaux à YC4 (18) sur le PWB du moteur.
 12. Desserrez la vis (19) pour que l'unité d'entraînement du séparateur de travaux soit prête à démarrer.
 13. Resserrez la vis (19).
 14. Remettez le capot (16) en place en utilisant la vis (15) retirée auparavant lors de l'étape 8.

-
11. Conecte el conector (17) en el lado trasero del separador de trabajos a YC4 (18) en el PWB de motor.
 12. Afloje el tornillo (19) para que la unidad de accionamiento del separador de trabajos esté lista para accionar.
 13. Apriete el tornillo (19).
 14. Vuelva a colocar la cubierta (16) utilizando el tornillo (15) sacado en el paso 8.

-
11. Den Steckverbinder (17) auf der Rückseite des Job-Separators an YC4 (18) der Motorplatine anschließen.
 12. Die Schraube (19) lösen, um die Antriebseinheit des Job-Separators für den Antriebsstart bereit zu machen.
 13. Die Schraube (19) festziehen.
 14. Die Abdeckung (16) wieder mit der in Schritt 8 entfernten Schraube (15) anbringen.

-
11. Collegare il connettore (17) sul lato posteriore del separatore lavori al YC4 (18) del motore PWB.
 12. Allentare la vite (19) per preparare l'unità guida del separatore lavori al funzionamento.
 13. Stringere la vite (19).
 14. Rimettete a posto il coperchio (16) utilizzando la vite (15) rimossa nel passo 8.

-
11. 将作业分离器后面的插头 (17) 插在引擎主板的 YC4(18) 上。
 12. 松弛 1 个螺丝 (19)，使驱动组件处于始动状态。
 13. 然后，紧固 1 个螺丝 (19)。
 14. 在步骤 8 拆下的盖板 (16)，用 1 个螺丝 (15) 按原样装好。

-
11. ジョブセパレータ後側のコネクタ (17) をエンジン回路基板の YC4(18) に接続する。
 12. ビス (19) 1 本をゆるめ、駆動ユニットを駆動がかかる状態にする。
 13. ビス (19) 1 本を締める。
 14. 手順 8 で取り外したカバー (16) をビス (15) 1 本で元通り取り付け。

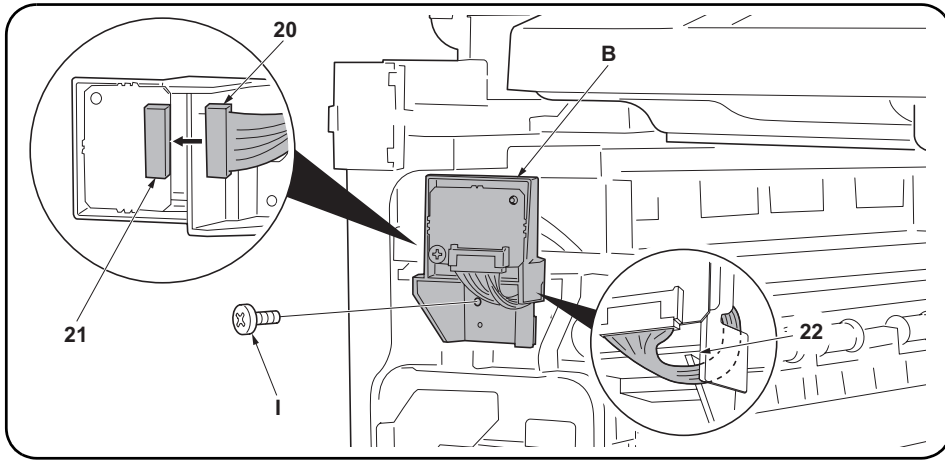

Attaching the LED PWB unit

15. Connect the connector (20) of the job separator to the connector (21) of the LED PWB unit (B).
 16. Pass the wires through the space (22) and fix the LED PWB unit (B) using the M3 × 6 screw (I).

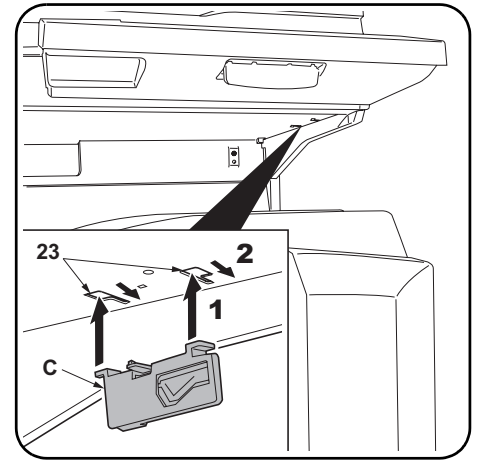

Installing the job separator tray

17. Insert the tray holder (C) into two openings (23) and then slide the holder to the right until it clicks.

Fixation de l'unité LED PWB

15. Branchez le connecteur (20) du séparateur de travaux au connecteur (21) de l'unité LED PWB (B).
 16. Faites passer les fils par l'espace (22) et fixez l'unité LED PWB (B) à l'aide de la vis M3 × 6 (I).

Installation du plateau du séparateur de travaux

17. Insérez le support de plateau (C) dans les deux ouvertures (23), puis faites glisser le support vers la droite jusqu'à ce qu'il s'encliquète.

Colocación de la unidad PWB LED

15. Conecte el conector (20) del separador de trabajos en el conector (21) de la unidad PWB LED (B).
 16. Pase los cables por el espacio (22) y fije la unidad PWB LED (B) utilizando el tornillo M3 × 6 (I).

Instalación de la bandeja de separador de trabajos

17. Inserte el soporte de bandeja (C) en dos aberturas (23) y deslice el soporte a la derecha hasta escuchar un chasquido.

Anbringen der LED-Platineneinheit

15. Den Steckverbinder (20) des Job-Separators mit dem Steckverbinder (21) der LED-Platineneinheit (B) verbinden.
 16. Die Kabel durch den Spalt (22) führen, und die LED-Platineneinheit (B) mit der M3 × 6 Schraube (I) befestigen.

Installieren des Job-Separator-Fachs

17. Den Fachhalter (C) in die zwei Öffnungen (23) einführen, und dann den Halter nach rechts schieben, bis er mit einem Klicken einrastet.

Montaggio dell'unità LED PWB

15. Collegare il connettore (20) del separatore lavori al connettore (21) dell'unità LED PWB (B).
 16. Fare passare i cavi attraverso lo spazio (22) e fissare l'unità LED PWB (B) utilizzando la vite M3 × 6 (I).

Installazione del vassoio del separatore lavori

17. Inserire il supporto del vassoio (C) nelle due aperture (23) e poi fare scorrere il supporto a destra fino a che non si mette in posizione con un clic.

安装 LED 电路板组件

15. 将作业分离器的插头 (20) 插在 LED 电路板组件 (B) 的插座 (21) 上。
 16. 将电线穿过间隙 (22)，用 1 个螺丝 M3 × 6 (I) 固定 LED 电路板组件 (B)。

安装作业分离器托盘

17. 将托盘座 (C) 插入 2 处开口部 (23)，向右侧滑动直至听到咔叽声为止。

LED 基板ユニットの取り付け

15. ジョブセパレータのコネクタ (20) を LED 基板ユニット (B) のコネクタ (21) に接続する。
 16. 電線をすきま (22) に通し、ビス M3 × 6 (I) 1 本で LED 基板ユニット (B) を取り付ける。

ジョブセパレータトレイの取り付け

17. トレイホルダ (C) を開口部 (23) 2 箇所に挿入し、カチッと音がするまで右側にスライドする。

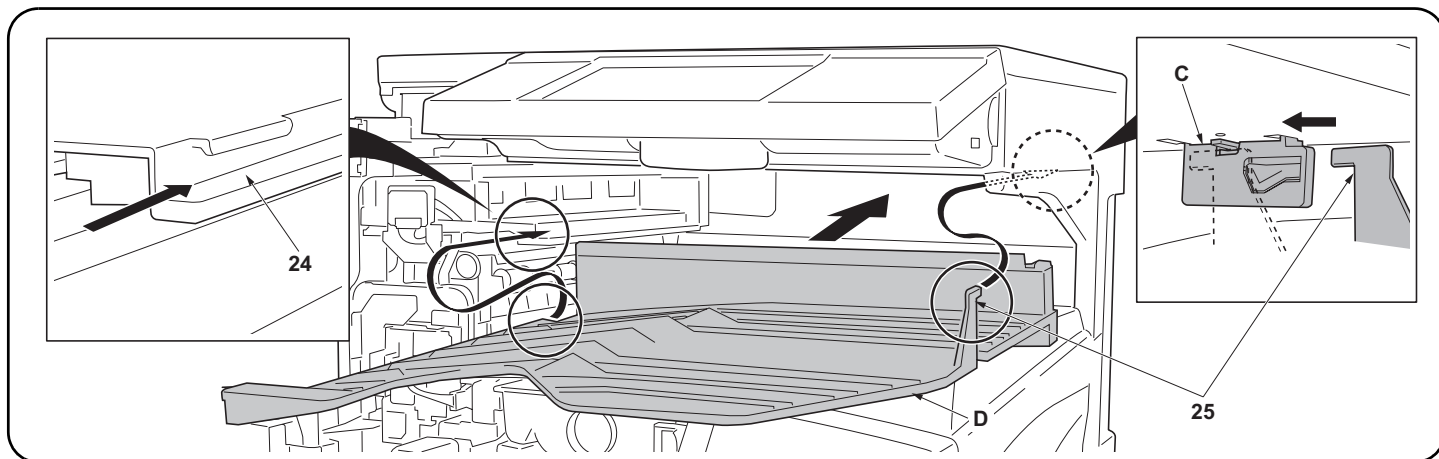

18. Install the job separator tray (D) from the front side of the machine.

Left: Insert the tray into the groove (24).

Right: Hang the hook (25) on the tray holder (C).

18. Installez le plateau du séparateur de travaux (D) depuis le côté avant de la machine.

Gauche: Insérez le plateau dans la rainure (24).

Droite: Suspendez le crochet (25) au support de plateau (C).

18. Instale la bandeja de separador de trabajos (D) desde el lado delantero de la máquina.

Izquierda: Inserte la bandeja en la ranura (24).

Derecha: Cuelgue el gancho (25) en el soporte de bandeja (C).

18. Das Job-Separator-Fach (D) von der Vorderseite der Maschine installieren.

Links: Das Fach in die Nut (24) einführen.

Rechts: Den Haken (25) in den Fachhalter (C) einhängen.

18. Installare il vassoio del separatore lavori (D) dal lato anteriore della macchina.

Lato sinistro: inserire il vassoio nell'incavo (24).

Lato destro: appendere il gancio (25) sul supporto del vassoio (C).

18. 从机器主机前面插入作业分离器托盘 (D)，进行安装。

左侧：插在沟槽 (24) 上。

右侧：将构件 (25) 挂在托盘座 (C) 上。

18. ジョブセパレータトレイ (D) を機械本体前側から挿入し、取り付ける。

左側：溝 (24) に挿入する。

右側：フック (25) をトレイホルダ (C) に引っ掛ける。

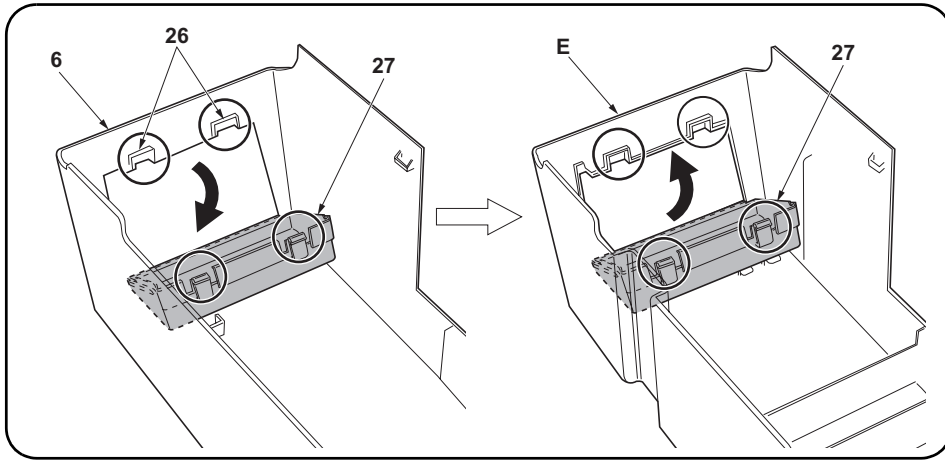

Installing the left front cover

19. Release two latches (26) of the cover (6) removed in step 3 using a flat-head screwdriver to remove the lower clip holder (27).
20. Attach the lower clip holder (27) to the left front cover (E).

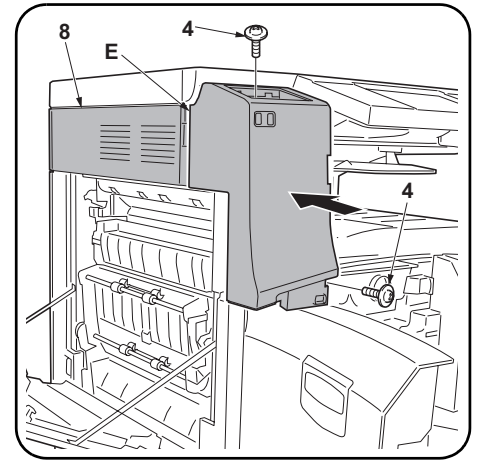

21. Replace the cover (8) removed in step 4.
22. Install the left front cover (E) using the two screws (4) removed in step 3.
23. Replace the clip holder (3) removed in step 2.
24. Close left cover 1 (2) and the front cover (1).

Installation du capot avant gauche

19. Libérez les deux verrous (26) du capot (6) retiré auparavant lors de l'étape 3 en utilisant un tournevis à tête plate pour retirer le support de pince inférieur (27).
20. Fixez le support à pince inférieur (27) sur le capot avant gauche (E).

21. Remettez en place le capot (8) retiré auparavant lors de l'étape 4.
22. Installez le capot avant gauche (E) à l'aide des deux vis (4) retirées auparavant lors de l'étape 3.
23. Remettez en place le support à pince (3) retiré auparavant lors de l'étape 2.
24. Refermez le capot gauche 1 (2) et le capot avant (1).

Instalación de la cubierta delantera izquierda

19. Suelte los dos pestillos (26) de la cubierta (6) desmontada en el paso 3 utilizando el destornillador de punta plana para desmontar el soporte de clip inferior (27).
20. Coloque el soporte de clip inferior (27) en la cubierta delantera izquierda (E).

21. Vuelva a colocar la cubierta (8) desmontada en el paso 4.
22. Instale la cubierta delantera izquierda (E) utilizando los dos tornillos (4) sacados en el paso 3.
23. Vuelva a colocar el soporte de clip (3) desmontado en el paso 2.
24. Cierre la cubierta izquierda 1 (2) y la cubierta frontal (1).

Installieren der linken Frontabdeckung

19. Die zwei Rasten (26) der in Schritt 3 entfernten Abdeckung (6) mit einem Flachsraubenzieher lösen, um den unteren Büroklammerhalter (27) abzunehmen.
20. Den unteren Büroklammerhalter (27) an der linken Frontabdeckung (E) anbringen.

21. Die in Schritt 4 entfernte Abdeckung (8) wieder anbringen.
22. Die linke Frontabdeckung (E) mit den in Schritt 3 entfernten zwei Schrauben (4) installieren.
23. Den in Schritt 2 entfernten Büroklammerhalter (3) wieder anbringen.
24. Die linke Abdeckung 1 (2) und die Frontabdeckung (1) schließen.

Installazione del coperchio frontale sinistro

19. Rilasciate due fermi (26) del coperchio (6) rimosso nel passo 3 utilizzando un giravite a punta piatta per rimuovere il contenitore inferiore delle graffette (27).
20. Montare il contenitore inferiore delle graffette (27) al coperchio frontale sinistro (E).

21. Rimettere a posto il coperchio (8) rimosso nel passo 4.
22. Installare il coperchio frontale sinistro (E) utilizzando due viti (4) rimosse nel passo 3.
23. Rimettete al suo posto il contenitore delle graffette (3) rimosso nel passo 2.
24. Chiudete il coperchio sinistro 1 (2) e il coperchio anteriore (1).

安装左前盖板

19. 用一字形螺丝刀等松开在步骤 3 卸下的盖板 (6) 的 2 处嵌入板 (26), 并取下夹子盒下 (27)。
20. 将夹子盒下 (27) 装在左前盖板 (E) 上。

21. 将步骤 4 拆下的盖板 (8) 按原样装好。
22. 用步骤 3 卸下的 2 个螺丝 (4) 装上左前盖板 (E)。
23. 在步骤 2 拆下的夹子盒 (3) 按原样装好。
24. 关闭左盖板 1 (2) 和前盖板 (1)。

左前カバーの取り付け

19. 手順 3 で取り外したカバー (6) のはめ込み (26) 2 箇所をマイナスドライバーなどで解除し、クリップ入れ下 (27) を取り外す。
20. クリップ入れ下 (27) を左前カバー (E) に取り付ける。

21. 手順 4 で取り外したカバー (8) を元通り取り付け。
22. 手順 3 で外したビス (4) 2 本で左前カバー (E) を取り付け。
23. 手順 2 で取り外したクリップ入れ (3) を元通り取り付け。
24. 左カバー 1 (2) および前カバー (1) を閉じる。

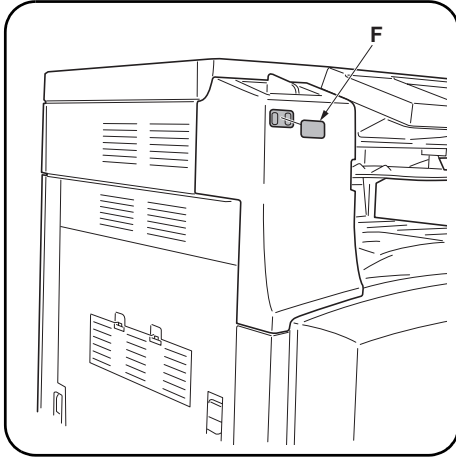

Adhering the blindfold seal (For models with monochrome touch panel only)

25. Clean the left front cover with alcohol and then adhere the blindfold seal (F).

Checking the operation

1. Connect the power plug of the machine to the wall outlet and turn the main power switch on.
2. Specify the output tray to the job separator tray from the system menu.

3. Make a proof copy to check that a copy is ejected to the job separator tray.

Collage de l'étiquette de masquage (pour les modèles équipés d'un écran tactile monochrome seulement)

25. Nettoyez le capot avant gauche avec de l'alcool, puis collez l'étiquette de masquage (F).

Vérification du fonctionnement

1. Insérer la fiche d'alimentation de la machine dans la prise murale et mettre la machine sous tension.
2. Définissez le bac de sortie sur le plateau du séparateur de travaux dans le menu système.

3. Effectuez une copie de test pour vérifier si une copie est bien éjectée sur le plateau du séparateur de travaux.

Pegado del sello ciego (Sólo modelos con panel de toque monocromático)

25. Limpie la cubierta delantera izquierda con alcohol y pegue el sello ciego (F).

Verificación del funcionamiento

1. Conecte el enchufe eléctrico de la máquina en un tomacorriente de la pared y conecte el interruptor principal.
2. Especifique como bandeja de salida a la bandeja del separador de trabajos en el menú del sistema.

3. Haga una copia de prueba para verificar que la copia sale a la bandeja del separador de trabajos.

Anbringen des Blindaufklebers (nur für Modelle mit Monochrom-Sensorbildschirm)

25. Die linke Frontabdeckung mit Alkohol reinigen, und dann den Blindaufkleber (F) anbringen.

Überprüfen des Betriebs

1. Den Netzstecker der Maschine in die Steckdose stecken und den Betriebsschalter einschalten.
2. Das Job-Separator-Fach über das Systemmenü als Ausgabefach angeben.

3. Eine Probekopie anfertigen, um zu prüfen, ob eine Kopie in das Job-Separator-Fach ausgeworfen wird.

Applicate il sigillo mascherina (solo per i modelli con pannello monocromatico a sfioramento)

25. Pulite il coperchio frontale sinistro con alcol e poi applicate il sigillo mascherina (F).

Verifica di funzionamento

1. Collegare la spina del cavo di alimentazione della macchina alla presa a muro della rete elettrica e accendere l'interruttore principale di alimentazione.
2. Specificare il vassoio di uscita al vassoio del separatore lavori mediante il menu sistema.

3. Effettuare una copia di prova per verificare che essa venga espulsa sul vassoio del separatore lavori.

貼上标贴

(只限单色触控式面板机)

25. 用酒精清洁后, 贴上标贴 (F)。

操作确认

1. 将机器主机上的电源插头插入插座中, 打开主电源开关。
2. 将系统菜单的排纸处设定在作业分离器托盘。

3. 进行测试复印, 确认纸张是否排在作业分离器托盘上。

シールの貼り付け

(モノクロタッチパネル機のみ)

25. アルコール清掃後、シール (F) を貼り付ける。

動作確認

1. 機械本体の電源プラグをコンセントに差し込み、主電源スイッチを ON にする。
2. システムメニューの排紙先をジョブセパレータトレイに設定する。

3. テストコピーをおこない、用紙がジョブセパレータトレイに排出されるかどうか確認する。

INSTALLATION GUIDE FOR FAX System

English

To install the FAX circuit board, see page 1.
To install the FAX circuit board as Dual FAX, see page 11.

Français

Pour installer la carte à circuits FAX, se reporter à la page 1.
Pour installer la carte à circuits FAX comme FAX double, se reporter à la page 11.

Español

Para instalar la tarjeta de circuitos de FAX, vea la página 1.
Para instalar la tarjeta de circuitos de FAX en el FAX dual, vea la página 11.

Deutsch

Angaben zur Installation der FAX-Leiterplatte finden Sie auf Seite 1.
Angaben zur Installation der FAX-Leiterplatte als Dual FAX finden Sie auf Seite 11.

Italiano

Per installare la scheda a circuiti FAX, vedere pagina 1.
Per installare la scheda a circuiti FAX come Dual FAX, vedere pagina 11.

简体中文

安装传真组件时…从第 1 页开始
安装多插口组件时…从第 11 页开始

日本語

ファクスシステムを設置する場合…1 ページから始める
マルチポートを設置する場合…11 ページから始める

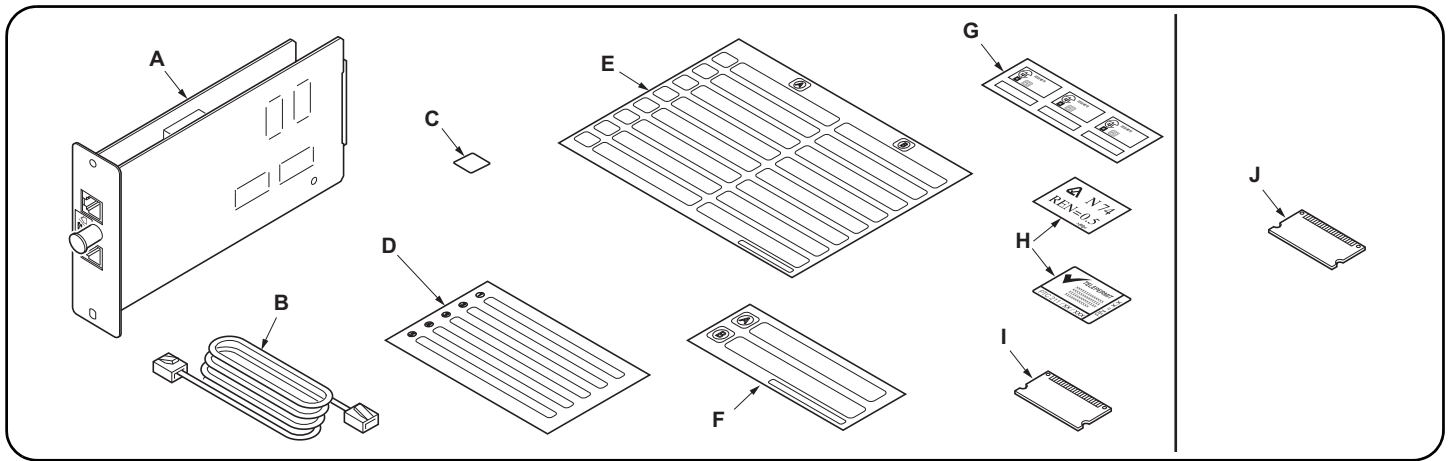

Supplied parts

A FAX circuit board	1
B Modular connector cable (120 V/Australian model only) PJJWC0016Z (UL Listed.HUAN HSIN Type TL:120 V only)	1
C Terminal seal	1
D Alphabet label	1

E FAX operation section label	1
H Approval label (Australian/New Zealand models only)	2
I Memory DIMM	1

(F) and (G) are not bundled.
When installing the Dual FAX, (A), (B), (C) are required.

Option

J Memory DIMM (128 MB)	1
------------------------------	---

Be sure to remove any tape and/or cushioning material from supplied parts.

Pièces fournies

A Carte à circuits FAX	1
B Câble du connecteur modulaire (modèles pour l'Australie/120 V seulement)	1
C Joint de borne	1
D Etiquette de l'alphabet	1
E Etiquette de la section de fonctionnement FAX	1

I Mémoire DIMM	1
----------------------	---

Option

J Mémoire DIMM (128 MB)	1
-------------------------------	---

(F), (G) et (H) ne sont pas fournis.
L'installation du Dual FAX requiert l'installation des pièces (A), (B), (C).

Veillez à retirer les morceaux de bande adhésive et/ou les matériaux de rembourrage des pièces fournies.

Piezas suministradas

A Tarjeta de circuitos de fax	1
B Cable conector modular (sólo para modelos de 120 V/Australianos)	1
C Sello del terminal	1
D Etiqueta de alfabeto	1
E Etiqueta de la sección de funcionamiento de FAX	1

I Memoria DIMM	1
----------------------	---

Opción

J Memoria DIMM (128 MB)	1
-------------------------------	---

(F), (G) y (H) no se suministran.
Cuando instale el fax Dual se necesitan (A), (B), (C).

Asegúrese de despegar todas las cintas y/o material amortiguador de las partes suministradas.

Gelieferte Teile

A FAX-Leiterplatte	1
C Verschlusskappe	1
D Alphabetaufkleber	1
E Aufkleber für FAX-Bedienungsabschnitt ..	1
I Speicher-DIMM	1

Option

J Speicher-DIMM (128 MB)	1
--------------------------------	---

(B), (F), (G) und (H) liegen nicht bei.
Für die Installation von Dual FAX sind (A), (C) erforderlich.

Entfernen Sie Klebeband und/oder Dämpfungsmaterial vollständig von den mitgelieferten Teilen.

Parti di forniture

A Scheda a circuiti FAX	1
C Guarnizione terminale	1
D Etichetta alfabetica	1
E Etichetta della sezione funzionamento FAX	1
I Memoria DIMM	1

Opzioni

J Memoria DIMM (128 MB)	1
-------------------------------	---

(B),(F),(G) e (H) non sono in dotazione.
Quando si installa il Dual FAX, sono necessari (A), (C).

Accertarsi di rimuovere tutti i nastri adesivi e/o il materiale di imbottitura dalle parti fornite.

附属品

A 传真电路板	1
B 电话线	1
C 端子密封	1
D 英文字母标签	1
E 传真操作部标签	1
I 内存模组 DIMM	1

选购件

J 内存模组 DIMM (128MB)	1
---------------------------	---

(F)、(G) 和 (H) 并非附属品。
安装多插口组件时，需要 (A)、(B)、(C)。

如果附属品上带有固定胶带，缓冲材料时务必揭下。

同梱品

A FAX 基板	1
B モジュラコード	1
C 端子シール	1
F FAX 操作部ラベル	1
G JATE ラベル	1
I メモリ DIMM	1

オプション

J メモリ DIMM (128MB)	1
--------------------------	---

(D), (E), (H) は、同梱されておりません。
マルチポート設置時は (A), (B), (C) のみが必要となる。

同梱品に固定テープ、緩衝材が付いている場合は必ず取り外すこと。

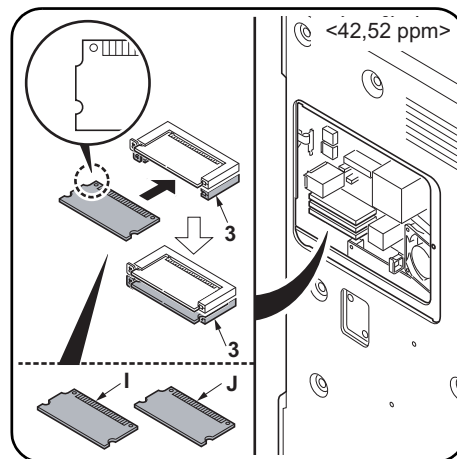
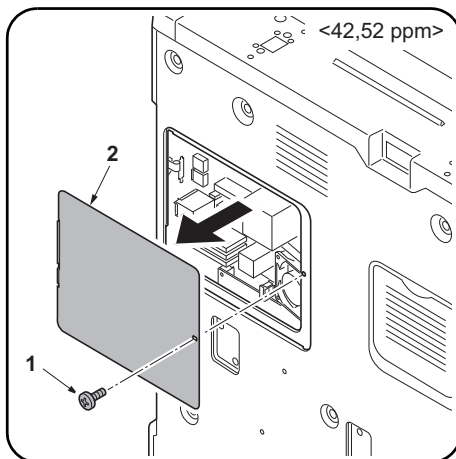

Precautions

Be sure to turn the MFP switch OFF and unplug the MFP from the power supply before installing the fax system.
The illustration of the MFP body in the Installation Guide is the 42,52 ppm model.

Procedure

Installing the memory DIMM <42,52 ppm (Monochrome machines)>

1. Remove 1 screw (1), and then remove the cover (2).

2. Install the memory DIMM (I) or the optional memory DIMM (J) into the memory slot (3) on the lower level (FLS).
Install it with the IC side facing down.
Insert it in the direction of the arrow until it clicks.
3. Replace the cover (2) using 1 screw (1).

Proceed to step 4 on page 5.

Précautions

Veiller à mettre l'interrupteur principal du MFP hors tension et à débrancher le MFP de la prise secteur avant d'installer le système fax.
L'illustration du corps du MFP dans le guide d'installation correspond au modèle 42,52 ppm.

Procédure

Installation de la mémoire DIMM <42,52 ppm (Machines monochromes)>

1. Déposer 1 vis (1) puis enlever le couvercle (2).

2. Installer la mémoire DIMM (I) ou la mémoire DIMM en option (J) dans la fente mémoire (3) se trouvant au niveau inférieur (FLS).
L'installer avec le côté IC en bas.
L'insérer dans la direction de la flèche jusqu'au clic.
3. Reposer le couvercle (2) à l'aide de 1 vis (1).

Passer à l'étape 4 de la page 5.

Precauciones

Asegúrese de apagar el MFP colocando el interruptor principal a OFF y desenchufe el MFP del suministro de red eléctrica antes de instalar el sistema de fax.
La ilustración del cuerpo del MFP en la Guía de instalación corresponde al modelo de 42,52 ppm.

Procedimiento

Instalación de la memoria DIMM <42,52 ppm (Maquinas monocromaticas)>

1. Quite 1 tornillo (1) y, después, desmonte la cubierta (2).

2. Instale la memoria DIMM (I), o la memoria DIMM opcional (J), en la ranura para la memoria (3) en el nivel inferior (FLS).
Instálolo con el lado IC hacia abajo.
Insértela en la dirección que indica la flecha hasta que escuche un clic.
3. Vuelva a colocar la cubierta (2) utilizando 1 tornillo (1).

Vaya al paso 4 de la página 5.

Vorsichtsmaßnahmen

Schalten Sie den Netzschalter des MFP aus und trennen Sie den MFP vom Netz, bevor Sie das Faxsystem installieren.
Die Abbildung des MFP-Geräts in der Installationsanleitung stellt das 42,52 ppm Modell dar.

Verfahren

Installation der DIMM-Speichermodule <42,52 ppm (Monochrommaschinen)>

1. Entfernen Sie 1 Schraube (1) und nehmen Sie dann die Abdeckung (2) ab.

2. Setzen Sie die DIMM-Speichermodule (I) oder das optionale DIMM-Speichermodule (J) in die untere Position (FLS) der Speicherbank (3) ein.
Mit der IC-Seite nach unten weisend installieren.
Schieben Sie das Modul in Pfeilrichtung, bis es hörbar einrastet.
3. Bringen Sie die Abdeckung (2) wieder mit 1 Schraube (1) an.

Gehen Sie zum Schritt 4 auf Seite 5 weiter.

Precauzioni

Assicurarsi di aver spento l'interruttore dell'MFP e di aver sfilato la spina dell'MFP dalla presa prima di installare il sistema fax.
L'illustrazione del corpo MFP nella Guida all'installazione è del modello da 42,52 ppm.

Procedura

Installazione della memoria DIMM <42,52 ppm (solo per le macchine)>

1. Rimuovere 1 vite (1), e quindi rimuovere il coperchio (2).

2. Installare la memoria DIMM (I) o la memoria DIMM opzionale (J) nello slot della memoria (3) al livello inferiore (FLS). Installare con il lato IC rivolto verso il basso. Inserirli nella direzione della freccia finché non scatta in posizione.
3. Sostituire il coperchio (2) utilizzando 1 vite (1).

Procedere con il punto 4 a pagina 5.

注意事項

请务必关闭 MFP 的开关并拔下电源插头再安装传真组件。
安装手册中插图所示多功能数码复合机主机为 42,52 张机型。

安装步骤

安装内存模组 DIMM <42,52 张机型 (黑白机器)>

1. 拆下 1 颗螺丝 (1), 然后拆下盖板 (2)。

2. 将内存模组 DIMM (I) 或者选购件 DIMM (J) 安装至下层 (FLS) 的内存插槽 (3)。安装时, 将 IC 侧正面朝下。沿箭头方向将其插入到底直至发出喀嗒声。
3. 使用 1 颗螺钉 (1) 更换盖板 (2)。

进行第 5 页上的第 4 步

注意事項

ファクスシステムを設置する場合は、MFP 本体の主電源スイッチを OFF にし、電源プラグを抜いてから作業をおこなう。
設置手順書に記載している MFP 本体のイラストは、42,52 枚機です。

取付手順

メモリ DIMM の取り付け <42,52 枚機 (モノクロ機)>

1. ビス (1) 1 本を外し、カバー (2) を取り外す。

2. メモリ DIMM (I) または、オプションのメモリ DIMM (J) を下段 (FLS) のメモリスロット (3) に取り付ける。
IC 面を下向きに取り付けること。
カチッと音がするまで矢印方向に挿入する。
3. ビス (1) 1 本で、カバー (2) を元通り取り付けする。

5 ページ手順 4 へ進む。

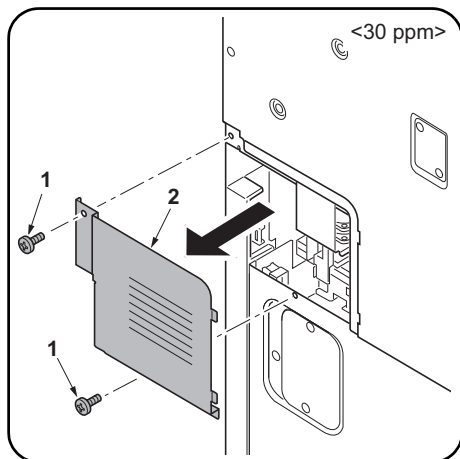

Installing the memory DIMM

<30 ppm (Monochrome machine)>

1. Remove 2 screws (1), and then remove the cover (2).

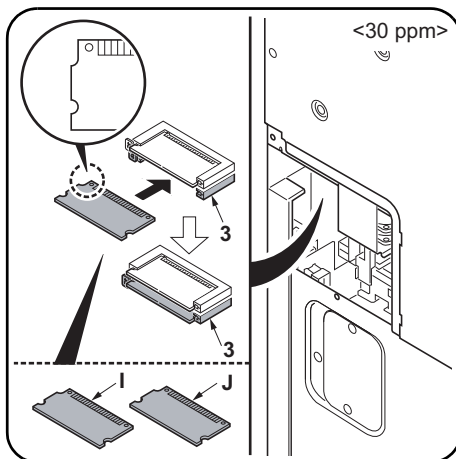

2. Install the memory DIMM (I) or the optional memory DIMM (J) into the memory slot (3) on the lower level (FLS). Install it with the IC side facing down. Insert it in the direction of the arrow until it clicks.
3. Replace the cover (2) using the 2 screws (1).

Proceed to step 4 on page 5.

Installation de la mémoire DIMM

<30 ppm (Machines monochromes)>

1. Déposez les 2 vis (1) puis enlevez le couvercle (2).

2. Installer la mémoire DIMM (I) ou la mémoire DIMM en option (J) dans la fente mémoire (3) se trouvant au niveau inférieur (FLS). L'installer avec le côté IC en bas. L'insérer dans la direction de la flèche jusqu'au clic.
3. Reposez le couvercle (2) à l'aide des 2 vis (1).

Passer à l'étape 4 de la page 5.

Instalación de la memoria DIMM

<30 ppm (Maquinas monocromaticas)>

1. Quite 2 tornillos (1) y, después, desmonte la cubierta (2).

2. Instale la memoria DIMM (I), o la memoria DIMM opcional (J), en la ranura para la memoria (3) en el nivel inferior (FLS). Instálolo con el lado IC hacia abajo. Insértela en la dirección que indica la flecha hasta que escuche un clic.
3. Vuelva a colocar la cubierta (2) utilizando los 2 tornillos (1).

Vaya al paso 4 de la página 5.

Installation der DIMM-Speichermodule

<30 ppm (Monochrommaschinen)>

1. Entfernen Sie 2 Schrauben (1) und nehmen Sie dann die Abdeckung (2) ab.

2. Setzen Sie die DIMM-Speichermodule (I) oder das optionale DIMM-Speichermodule (J) in die untere Position (FLS) der Speicherbank (3) ein. Mit der IC-Seite nach unten weisend installieren. Schieben Sie das Modul in Pfeilrichtung, bis es hörbar einrastet.
3. Bringen Sie die Abdeckung (2) wieder mit den 2 Schrauben (1) an.

Gehen Sie zum Schritt 4 auf Seite 5 weiter.

Installazione della memoria DIMM

<30 ppm (solo per le macchine)>

1. Rimuovere 2 viti (1), e quindi rimuovere il coperchio (2).

2. Installare la memoria DIMM (I) o la memoria DIMM opzionale (J) nello slot della memoria (3) al livello inferiore (FLS). Installare con il lato IC rivolto verso il basso. Inserirla nella direzione della freccia finché non scatta in posizione.
3. Ricollocare il coperchio (2) utilizzando le 2 viti (1).

Procedere con il punto 4 a pagina 5.

安装内存模组 DIMM

<30 张机型 (黑白机器)>

1. 取下 2 个螺丝 (1), 然后取下盖板 (2)。

2. 将内存模组 DIMM (I) 或者选配件 DIMM (J) 安装至下层 (FLS) 的内存插槽 (3)。安装时, 将 IC 侧正面朝下。沿箭头方向将其插入到底直至发出喀嗒声。
3. 使用 2 个螺丝 (1) 重新安装盖板 (2)。

进行第 5 页上的第 4 步

メモリ DIMM の取り付け

<30 枚機 (モノクロ機)>

1. ビス (1) 2 本を外し、カバー (2) を取り外す。

2. メモリ DIMM (I) または、オプションのメモリ DIMM (J) を下段 (FLS) のメモリスロット (3) に取り付ける。IC 面を下向きに取り付けること。カチッと音がするまで矢印方向に挿入する。
3. ビス (1) 2 本で、カバー (2) を元通り取り付けする。

5 ページ手順 4 へ進む。

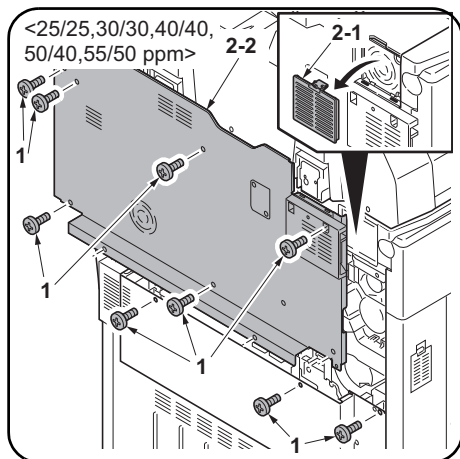

Installing the memory DIMM

<25/25, 30/30, 40/40, 50/40, 55/50 ppm
(Full-color machines)>

1. Remove the filter cover (2-1). Then remove 9 screws (1) and remove the upper rear cover (2-2).

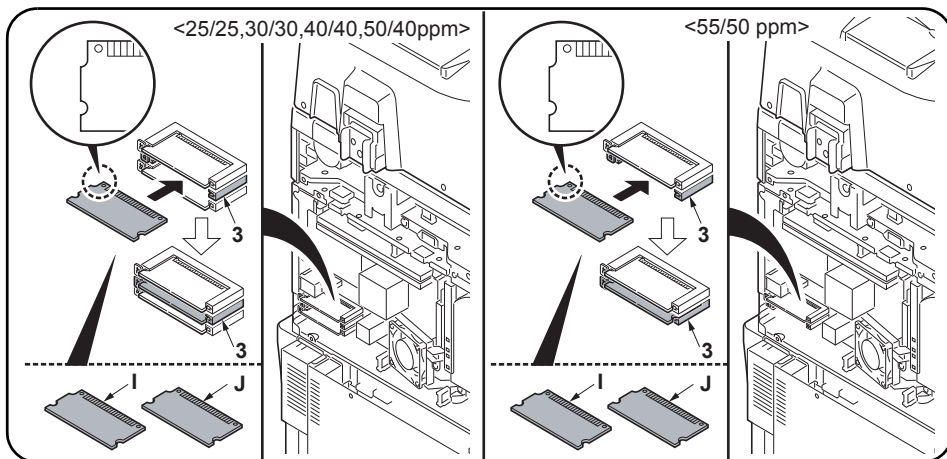

2. Install the memory DIMM (I) or the optional memory DIMM (J) into the memory slot (3) on the middle level (FLS) <25/25, 30/30, 40/40, 50/40 ppm>.
the lower level (FLS) <55/50 ppm>.
Install it with the IC side facing down. Insert it in the direction of the arrow until it clicks.
3. Replace the upper rear cover (2-2) using 9 screws (1) and then replace the filter cover (2-1).
Proceed to step 4 on page 5.

Installation de la mémoire DIMM

<25/25, 30/30, 40/40, 50/40, 55/50 ppm
(Machines entièrement en couleurs)>

1. Déposer le couvercle du filtre (2-1). Puis déposer les 9 vis (1) et le couvercle arrière supérieur (2-2).

2. Installer la mémoire DIMM (I) ou la mémoire DIMM en option (J) dans la fente mémoire (3) se trouvant
au milieu (FLS) <25/25, 30/30, 40/40, 50/40 ppm>.
au niveau inférieur (FLS) <55/50 ppm>.
L'installer avec le côté IC en bas. L'insérer dans la direction de la flèche jusqu'au clic.
3. Reposer le couvercle arrière supérieur (2-2) à l'aide des 9 vis (1), puis le couvercle du filtre (2-1).
Passer à l'étape 4 de la page 5.

Instalación de la memoria DIMM

<25/25, 30/30, 40/40, 50/40, 55/50 ppm
(Maquinas a todo color)>

1. Quite la cubierta del filtro (2-1). Luego quite los 9 tornillos (1) y retire la cubierta trasera superior (2-2).

2. Instale la memoria DIMM (I), o la memoria DIMM opcional (J), en la ranura para la memoria (3) en el nivel medio (FLS) <25/25, 30/30, 40/40, 50/40 ppm>.
el nivel inferior (FLS) <55/50 ppm>.
Instálolo con el lado IC hacia abajo. Insértela en la dirección que indica la flecha hasta que escuche un clic.
3. Vuelva a colocar la cubierta trasera superior (2-2) utilizando los 9 tornillos (1) y luego reinstale la cubierta del filtro (2-1).
Vaya al paso 4 de la página 5.

Installation der DIMM-Speichermodule

<25/25, 30/30, 40/40, 50/40, 55/50 ppm
(Vollfarbenkopierer)>

1. Entfernen Sie die Filterabdeckung (2-1). Entfernen Sie danach die 9 Schrauben (1) und nehmen Sie dann die obere hintere Abdeckung (2-2) ab.

2. Setzen Sie die DIMM-Speichermodule (I) oder das optionale DIMM-Speichermodule (J) in die mittlere Position (FLS) <25/25, 30/30, 40/40, 50/40 ppm> die untere Position (FLS) <55/50 ppm> der Speicherbank (3) ein.
Mit der IC-Seite nach unten weisend installieren. Schieben Sie das Modul in Pfeilrichtung, bis es hörbar einrastet.
3. Bringen Sie die obere hintere Abdeckung (2-2) wieder mit den 9 Schrauben (1) an und bringen Sie die Filterabdeckung (2-1) an.
Gehen Sie zum Schritt 4 auf Seite 5 weiter.

Installazione della memoria DIMM

<25/25, 30/30, 40/40, 50/40, 55/50 ppm
(un macchinario a colori)>

1. Rimuovere il coperchio del filtro (2-1). Quindi rimuovere le 9 viti (1) e il coperchio superiore posteriore (2-2).

2. Installare la memoria DIMM (I) o la memoria DIMM opzionale (J) nello slot della memoria (3) al livello centrale (FLS) <25/25, 30/30, 40/40, 50/40 ppm>.
livello inferiore (FLS) <55/50 ppm>.
Installare con il lato IC rivolto verso il basso. Inserirla nella direzione della freccia finché non scatta in posizione.
3. Ricollocare il coperchio superiore posteriore (2-2) utilizzando le 9 viti (1), e quindi ricollocare il coperchio del filtro (2-1).
Procedere con il punto 4 a pagina 5.

安装内存模组 DIMM

<25/25, 30/30, 40/40, 50/40, 55/50 张机型
(彩色机器)>

1. 取下过滤板盖板 (2-1) 后, 拆下 9 颗螺丝 (1), 然后拆下后上盖板 (2-2)。

2. 将内存模组 DIMM (I) 或者选购件 DIMM (J) 安装至
中层 (FLS) <25/25, 30/30, 40/40, 50/40 张机型>
下层 (FLS) <55/50 张机型>
的内存插槽 (3)。安装时, 将 IC 侧正面朝下。沿箭头方向将其插入到底直至发出喀嗒声。
3. 使用 9 颗螺丝 (1) 把后上盖板 (2-2) 按原样装回, 然后重新安装过滤板盖板 (2-1)。
进行第 5 页上的第 4 步

メモリ DIMM の取り付け

<25/25, 30/30, 40/40, 50/40, 55/50 枚機
(フルカラー機)>

1. フィルタカバー (2-1) を取り外した後、ビス (1) 9 本を外し、後上カバー (2-2) を取り外す。

2. メモリ DIMM (I) または、オプションのメモリ DIMM (J) を
中段 (FLS) <25/25, 30/30, 40/40, 50/40 枚機>
下段 (FLS) <55/50 枚機>
のメモリスロット (3) に取り付ける。
IC 面を下向きに取り付けること。
カチッと音がするまで矢印方向に挿入する。
3. ビス (1) 9 本で、後上カバー (2-2) を元通り取り付けした後、フィルタカバー (2-1) を元通り取り付け。
5 ページ手順 4 へ進む。

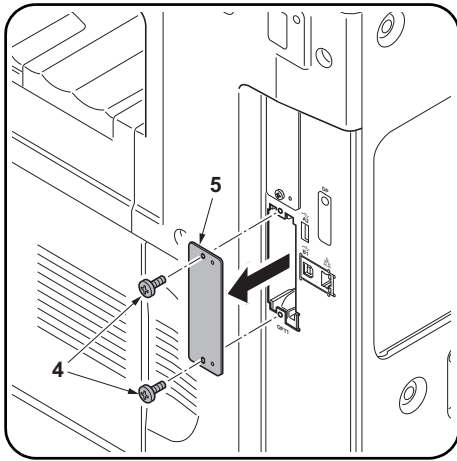

Remove the cover.

4. Remove two screws (4) and then remove OPT1 cover (5).

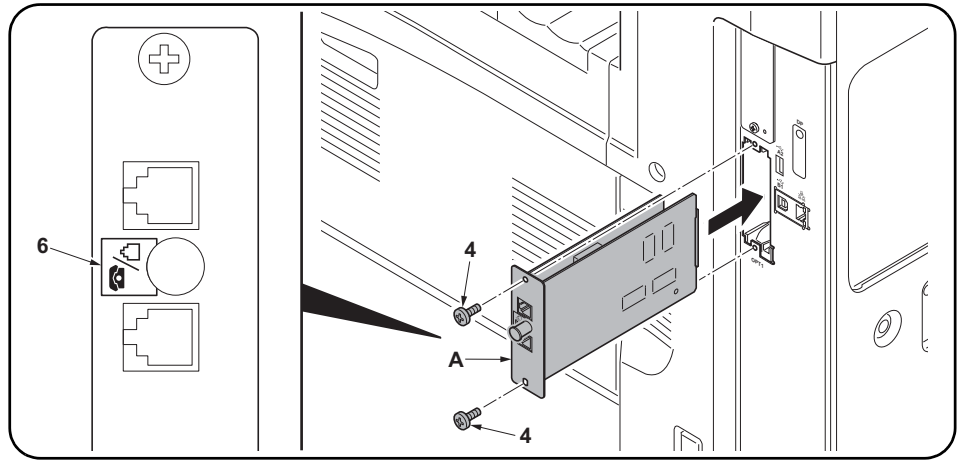

Install the FAX circuit board.

5. Insert the FAX circuit board (A) along the groove in OPT1 and secure the board with two screws (4) that have been removed in step 4.
Do not directly touch the FAX circuit board (A) terminal. Hold the top and bottom of the FAX circuit board, or the projection of the board to insert the FAX circuit board (A).
Direct the label (6) on to the FAX circuit board (A) as indicated in the illustration and insert the board along the groove.

Retirer le couvercle.

4. Retirer les deux vis (4), puis le couvercle OPT1 (5).

Installer la carte à circuits FAX.

5. Insérer la carte à circuits FAX (A) le long de la rainure dans l'OPT1 et la fixer à l'aide des deux vis (4) retirées à l'étape 4.
Ne pas toucher directement la borne de la carte à circuits FAX (A). Tenir les parties inférieure et supérieure de la carte à circuits FAX ou la saillie de la carte pour insérer la carte à circuits FAX (A).
Orienter l'étiquette (6) de la carte à circuits FAX (A) comme illustré et insérer la plaquette le long de la rainure.

Desmonte la cubierta.

4. Quite dos tornillos (4) y desmonte la cubierta OPT1 (5).

Instale la tarjeta de circuitos de fax.

5. Inserte la tarjeta de circuitos de fax (A) a lo largo de la ranura de OPT1 y asegúrela con los dos tornillos (4) que ha quitado en el paso 4.
No toque directamente el terminal de la tarjeta de circuitos del fax (A). Sujete las partes superior e inferior de la tarjeta de circuitos de fax o la saliente de la tarjeta para insertar la tarjeta de circuitos de fax (A).
Oriente la etiqueta (6) en la tarjeta de circuitos del FAX (A) como se indica en la ilustración e inserte la tarjeta a lo largo de la ranura.

Entfernen der Abdeckung.

4. Die beiden Schrauben (4) herausdrehen und Abdeckung OPT1 (5) abnehmen.

Einbauen der FAX-Leiterplatte.

5. FAX-Leiterplatte (A) in die Nut des Einbauschachts OPT1 einsetzen und Leiterplatte mit den in Schritt 4 ausgebauten Schrauben (4) befestigen.
Berühren Sie die Anschlüsse der FAX-Platine (A) nicht mit den Fingern. Die FAX-Leiterplatte (A) beim Einsetzen oben und unten oder an dem Vorsprung festhalten.
Die FAX-Leiterplatte (A) so in die Nut einsetzen, dass der Aufkleber (6) wie abgebildet zur Leiterplatte zeigt.

Rimuovere il coperchio.

4. Rimuovere le due viti (4), quindi rimuovere il coperchio OPT1 (5).

Montaggio della scheda a circuiti FAX.

5. Inserire la scheda a circuiti FAX (A) lungo l'incavo nell'OPT1 e fissare la scheda con le due viti (4) rimosse nell'operazione 4.
Non toccare direttamente il terminale della scheda a circuiti FAX (A). Per inserire il circuito FAX (A), tenere l'estremità superiore e la base della scheda a circuiti FAX, o la sporgenza della scheda a circuiti FAX.
Orientare l'etichetta (6) sulla scheda a circuiti FAX (A) come indicato nell'illustrazione e inserire la scheda lungo l'incavo.

拆下盖板

4. 拆下 2 顆螺釘 (4)，然後拆下 OPT1 盖板 (5)。

安裝傳真電路板

5. 沿著 OPT1 的溝槽插入傳真電路板 (A) 並用在步驟 4 中拆下的兩顆螺釘 (4) 固定電路板。
請勿直接觸摸傳真電路板 (A) 端子。按住傳真電路板的頂部和底部，或者按住電路板的突出部將傳真電路板 (A) 插入。
將傳真電路板 (A) 上的標籤 (6) 保持圖示中的方向，將電路板沿著溝槽方向插入。

カバーの取り外し

4. ビス (4) 2 本を外し、OPT1 のカバー (5) を取り外す。

FAX 基板の取り付け

5. OPT1 の溝に沿って FAX 基板 (A) を挿入し、手順 4 で外したビス (4) 2 本で固定する。
FAX 基板 (A) の端子に直接触れないこと。FAX 基板 (A) の挿入時は基板の上下か突起を持つこと。
FAX 基板 (A) は、貼り付けられているラベル (6) が図に示す方向になるように、挿入すること。

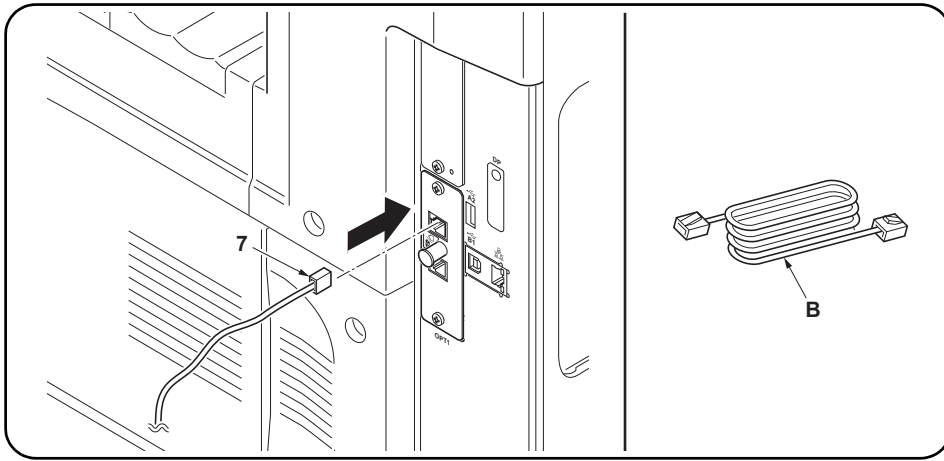

Connect the MFP to the telephone line.

6. Plug the modular connector cable (7) into the line terminal, and then connect the other end to the telephone line.

For 100 V/120 V/Australian or Chinese models, use the supplied modular connector cable (B).

Connecter le MFP à la ligne de téléphone.

6. Brancher le câble du connecteur modulaire (7) à la borne de la ligne, puis connecter l'autre extrémité à la ligne de téléphone.

Pour les modèles 100 V/120 V/Australie ou Chine, utilisez le câble à connecteur modulaire (B) fourni.

Conecte el MFP a la línea telefónica.

6. Enchufe el cable del conector modular (7) en el terminal de línea y, a continuación, conecte el otro extremo a la línea telefónica.

Para los modelos de 100 V/120 V/Australiano o Chino, utilice el cable conector modular (B) suministrado.

Anschließen des MFP an die Telefonleitung.

6. Telefonmodulkabel (7) in die Gerätebuchse einstecken und das Kabel an der Telefondose anschließen.

Das mitgelieferte Modularsteckerkabel (B) für die 100-V/120-V/Australien- oder China-Modelle verwenden.

Collegamento dell'MFP alla linea del telefono.

6. Inserire il cavo connettore modulare (7) nel terminale della linea, e quindi collegare l'altro terminale alla linea del telefono.

Per modelli da 100 V/120 V/Australia o Cina, utilizzare il cavo connettore modulare (B) in dotazione.

将 MFP 连接到电话线

6. 将模块接插件电缆 (7) 插入电话线端子, 然后将另一端与电话线连接。

对于 100 V/120 V / 澳大利亚或中国机型, 请使用随附的模块接插件电缆 (B)。

電話回線との接続

6. モジュラコード (7) をライン端子に差し込む。もう片方のプラグは、電話回線へ接続する。

100V/120V/ オーストラリア仕様 / 中国仕様は付属のモジュラコード (B) を使用すること。

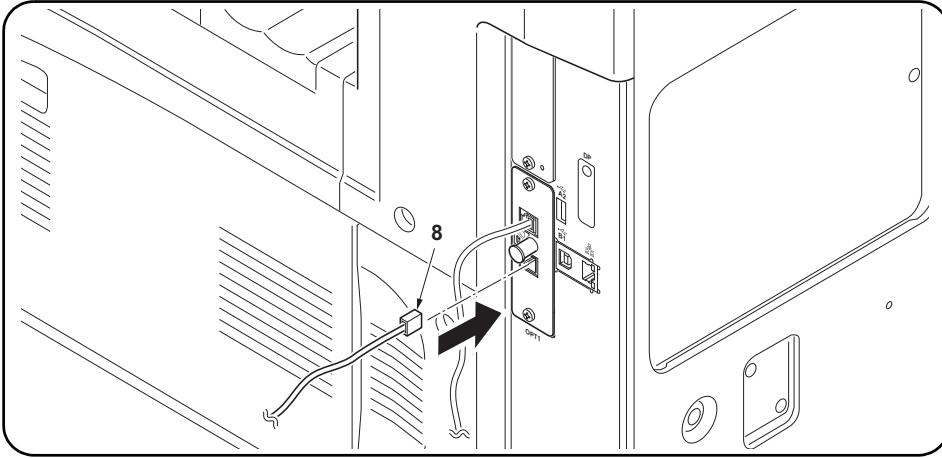

Connect the MFP to the separate phone (except for New Zealand model).

7. Plug the modular connector cable (8) into the telephone terminal, and then connect the other end to the separate phone.

If you don't connect the MFP to the separate phone, wipe the surface of the telephone terminal with alcohol and adhere the terminal seal (C) upon the customer's request.

Connecter le MFP au téléphone séparé .

7. Brancher le câble du connecteur modulaire (8) à la borne du téléphone, puis connecter l'autre extrémité au téléphone séparé.

Si le MFP n'est pas connecté au téléphone séparé à la demande du client, nettoyer la surface de la borne de téléphone avec de l'alcool et apposer le joint de borne (C).

Conecte el MFP al teléfono separado .

7. Enchufe el cable del conector modular (8) en el terminal del teléfono y, a continuación, conecte el otro extremo al teléfono separado.

Si no conecta el MFP a un teléfono separado, limpie la superficie del terminal del teléfono con alcohol y pegue el sello del terminal (C), a solicitud del cliente.

Anschließen des MFP an das separate Telefon .

7. Das Telefonmodulkabel (8) in die Telefonbuchse einstecken und das andere Ende an das separate Telefon anschließen.

Wenn der MFP nicht an das separate Telefon angeschlossen wird, die Oberfläche der Telefonbuchse mit Alkohol abwischen und Verschlusskappe (C) einsetzen, falls vom Kunden gewünscht.

Collegamento dell'MFP al telefono separato .

7. Inserire il cavo connettore modulare (8) nel terminale del telefono, e quindi collegare l'altro terminale al telefono separato.

Nel caso in cui non si colleghi l'MFP al telefono separato, pulire la superficie del terminale del telefono con dell'alcol e applicare la guarnizione terminale (C) a richiesta del cliente.

将 MFP 连接到其它电话

7. 将模块接插件电缆 (8) 插入电话端子, 然后将另一端与其它电话连接。

如果您没有将 MFP 连接至其他电话, 请用酒精擦拭电话端子表面, 并按照客户要求粘上端子密封 (C)。

外付け電話との接続

7. モジュラコード (8) を TEL 端子に差し込む。もう片方のプラグは、外付け電話と接続する。

(外付け電話と接続しない場合、お客様の要望により、TEL 端子周囲をアルコール清掃し、端子シール (C) を貼り付ける。)

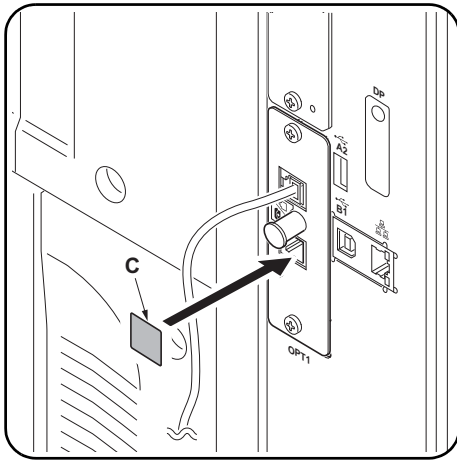

Seal the terminal (for New Zealand model).

8. Wipe the surface of the telephone terminal with alcohol and adhere the terminal seal (C).
Perform this procedure for New Zealand model only.

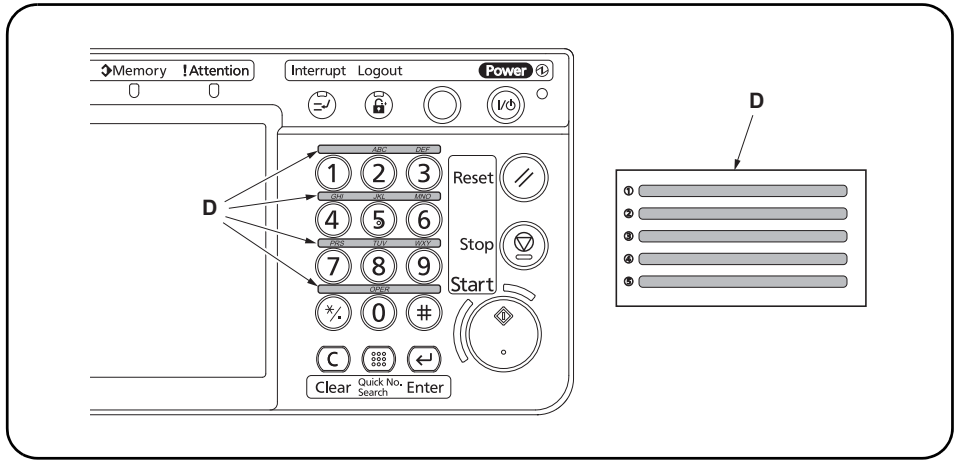

Attach the alphabet labels.

9. Wipe the area above the numeric keys at the right side of the operation panel with alcohol and adhere the alphabet labels (D) here.
In Asia and Oceania, use PQRS TUV WXYZ label, and do not use PRS TUV WXY and OPER labels.

Fermer hermétiquement la borne (modèle pour la Nouvelle-Zélande).

8. Effectuer cette procédure pour le modèle pour la Nouvelle-Zélande seulement.

Fixer les étiquettes de l'alphabet.

9. Nettoyer la surface au-dessus des touches numériques à droite du panneau de commande et y coller les étiquettes de l'alphabet (D).
En Asie et Océanie, utiliser l'étiquette PQRS TUV WXYZ et pas les étiquettes PRS TUV WXY et OPER.

Selle el terminal (para el modelo Nuevo Zelandés).

8. Realice este procedimiento sólo para el modelo Nuevo Zelandés.

Fije las etiquetas de alfabeto.

9. Limpie la zona situada encima de las teclas numéricas, en el lado derecho del panel de trabajo, y pegue aquí las etiquetas de alfabeto (D).
En Asia y Oceanía, utilice la etiqueta PQRS TUV WXYZ y no use las PRS TUV WXY ni las OPER.

Versiegeln der Anschlussbuchse (für Neuseeland-Modell).

8. Dieses Verfahren nur für das Neuseeland-Modell anwenden.

Anbringen der Alphabetaufkleber.

9. Den Bereich über den Zifferntasten auf der rechten Seite des Bedienfeldes abwischen und die Alphabetaufkleber (D) hier anbringen.
In Asien und Ozeanien den Aufkleber PQRS TUV WXYZ verwenden; nicht die Aufkleber PRS TUV WXY und OPER verwenden.

Sigillare il terminale (per il modello Nuova Zelanda).

8. Eseguire questa procedura solo per il modello Nuova Zelanda.

Applicazione delle etichette alfabetiche.

9. Pulire l'area sopra i tasti numerici sul lato destro del pannello operativo e attaccare qui le etichette alfabetiche (D).
In Asia ed Oceania, utilizzare l'etichetta PQRS TUV WXYZ e non utilizzare le etichette PRS TUV WXY e OPER.

安装端子密封（仅适用于新西兰型号）

8. 该操作步骤仅适用于新西兰型号。

安装英文字母标签

9. 擦拭操作面板右侧数字键上的区域，然后将英文字母标签 (D) 粘在此处。
在亚洲和大洋州，请使用 PQRS TUV WXYZ 标签，而不要使用 PRS TUV WXY 和 OPER 标签。

端子シールの貼り付け（ニュージーランド仕様のみ）

8. この手順はニュージーランド仕様のみおこなう。

アルファベットラベルの貼り付け（100V仕様以外）

9. この作業は、不要です。

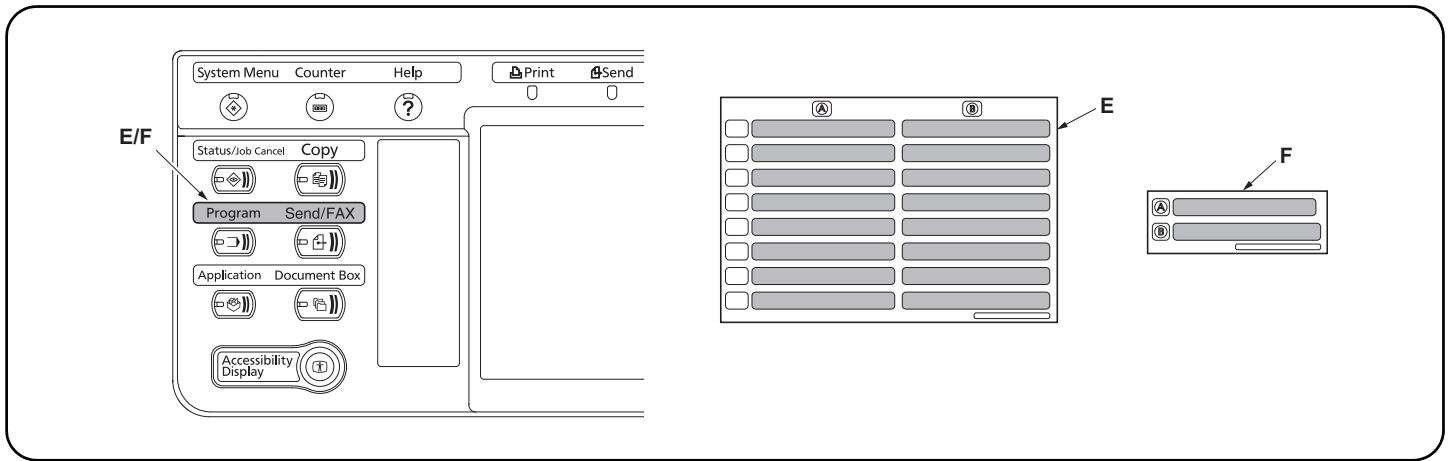

Attach the FAX operation section label.

10. Wipe the label surface shown in the figure with alcohol and adhere the FAX operation section label (E) of the corresponding language.

<When installing in 42,52 ppm (Monochrome machines)>

Adhere the FAX operation section label (E) that A is shown.

<When installing in 30 ppm (Monochrome machines)>

Adhere the FAX operation section label (E) that B is shown.

<When installing in 25/25,30/30,40/40,50/40,55/50 ppm (Full-color machines)>

Adhere the FAX operation section label (E) that A is shown.

Fixer l'étiquette de la section de fonctionnement FAX.

10. Essuyer avec de l'alcool la surface de l'étiquette montrée sur l'illustration, et apposer l'étiquette de la section de fonctionnement FAX (E) de la langue correspondante.

<Installation sur les modèles 42,52 ppm (Machines monochromes)>

Apposer l'étiquette de la section de fonctionnement FAX (E) de manière que A soit montré.

<Installation sur les modèles 30 ppm (Machines monochromes)>

Apposer l'étiquette de la section de fonctionnement FAX (E) de manière que B soit montré.

<Installation sur les modèles 25/25,30/30,40/40,50/40,55/50 ppm (Machines entièrement en couleurs)>

Apposer l'étiquette de la section de fonctionnement FAX (E) de manière que A soit montré.

Coloque la etiqueta de la sección de funcionamiento de FAX.

10. Limpie la superficie de la etiqueta que aparece en la figura con alcohol y pegue la etiqueta de la sección de funcionamiento de FAX (E) del correspondiente idioma.

<Cuando instale en 42,52 ppm (Maquinas monocromaticas)>

Pegue la etiqueta de la sección de funcionamiento de FAX (E) indicada en A.

<Cuando instale en 30 ppm (Maquinas monocromaticas)>

Pegue la etiqueta de la sección de funcionamiento de FAX (E) indicada en B.

<Cuando instale en 25/25,30/30,40/40,50/40,55/50 ppm (Maquinas a todo color)>

Pegue la etiqueta de la sección de funcionamiento de FAX (E) indicada en A.

Anbringen des Aufklebers für den FAX-Bedienungsabschnitt.

10. Die in der Abbildung gezeigte Klebefläche des Aufklebers mit Alkohol reinigen, und den Aufkleber für den FAX-Bedienungsabschnitt (E) der entsprechenden Sprache anbringen.

<Bei Einbau in 42,52 ppm (Monochrommaschinen)>

Den bei A gezeigten Aufkleber für den FAX-Bedienungsabschnitt (E) anbringen.

<Bei Einbau in 30 ppm (Monochrommaschinen)>

Den bei B gezeigten Aufkleber für den FAX-Bedienungsabschnitt (E) anbringen.

<Bei Einbau in 25/25,30/30,40/40,50/40,55/50 ppm (Vollfarbenkopierers)>

Den bei A gezeigten Aufkleber für den FAX-Bedienungsabschnitt (E) anbringen.

Fissare l'etichetta della sezione funzionamento FAX.

10. Pulire con alcol la superficie dell'etichetta indicata nella figura e applicare l'etichetta della sezione funzionamento FAX (E) della lingua corrispondente.

<Quando si installa nel 42,52 ppm (solo per le macchine)>

Applicare l'etichetta della sezione funzionamento FAX (E) indicata da A.

<Quando si installa nel 30 ppm (solo per le macchine)>

Applicare l'etichetta della sezione funzionamento FAX (E) indicata da B.

<Quando si installa nel 25/25,30/30,40/40,50/40,55/50 ppm (un macchinario a colori)>

Applicare l'etichetta della sezione funzionamento FAX (E) indicata da A.

粘貼传真操作部标签

10. 用酒精擦拭图示位置的标签贴面后, 粘贴相应语言的传真操作部标签 (E)。

<安装在 42, 52 张机型号 (黑白机器) 上时>

将印刷的 A 的传真操作部标签 (E) 粘在此处。

<安装在 30 张机型号 (黑白机器) 上时>

将印刷的 B 的传真操作部标签 (E) 粘在此处。

<安装在 25/25, 30/30, 40/40, 50/40, 55/50 张机型号 (彩色机器) 上时>

将印刷的 A 的传真操作部标签 (E) 粘在此处。

FAX 操作部ラベルの貼り付け

10. イラストの位置のラベル上面をアルコール清掃後、該当する言語の FAX 操作部ラベル (F) を貼り付ける。

<42, 52 枚機 (モノクロ機) に設置する場合>

A と印刷されている FAX 操作部ラベル (F) を貼り付ける。

<30 枚機 (モノクロ機) に設置する場合>

B と印刷されている FAX 操作部ラベル (F) を貼り付ける。

<25/25, 30/30, 40/40, 50/40, 55/50 枚機 (フルカラー機) に設置する場合>

A と印刷されている FAX 操作部ラベル (F) を貼り付ける。

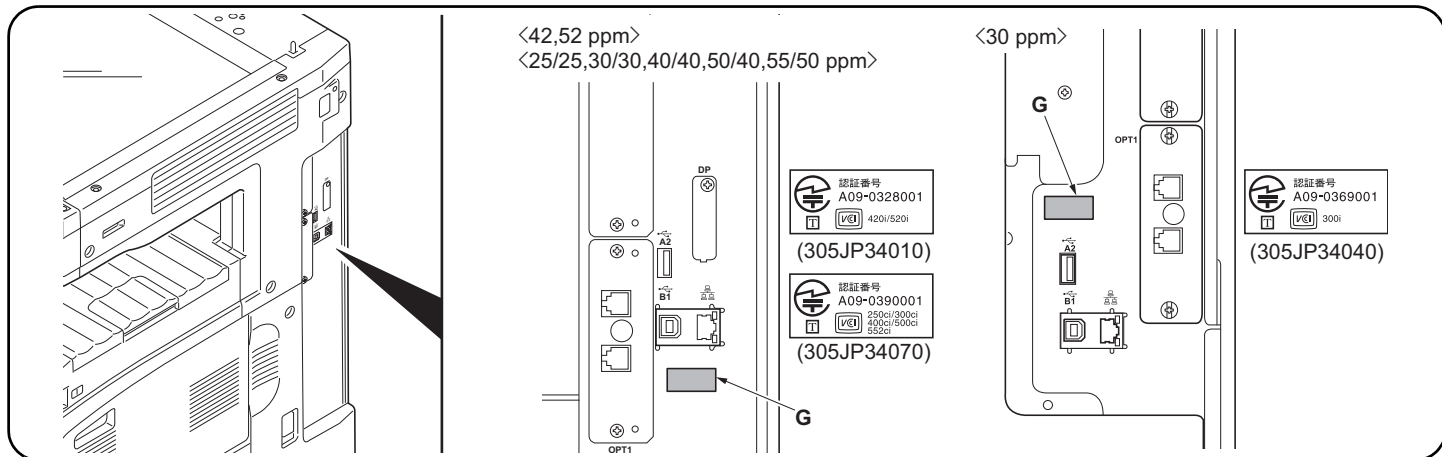

Attach the JATE label (for 100 V model only).
 11. Perform this procedure for 100 V model only.

Fixer l'étiquette JATE (modèle 100 V seulement).
 11. Effectuer cette procédure pour le modèle 100 V seulement.

Coloque la etiqueta JATE (sólo para el modelo de 100 V).
 11. Realice el procedimiento sólo para el modelo de 100 V.

Den JATE-Aufkleber anbringen (nur für 100-V-Modell).
 11. Dieses Verfahren nur für das 100-V-Modell anwenden.

Applicare l'etichetta JATE (solo per il modello da 100 V).
 11. Eseguire questa procedura solo per il modello da 100 V.

粘貼 JATE 标签 (仅适用于 100V 型号)
 11. 该步骤仅适用于 100V 型号时操作。

JATE ラベルの貼り付け (100V 仕様のみ)

11. アルコール清掃後、JATE ラベル (G) を貼り付ける。
 - < 42, 52 枚機 (モノクロ機) に設置する場合 >
 305JP34010 と印刷されている JATE ラベル (G) を貼り付ける。
 - < 30 枚機 (モノクロ機) に設置する場合 >
 305JP34040 と印刷されている JATE ラベル (G) を貼り付ける。
 - < 25/25, 30/30, 40/40, 50/40, 55/50 枚機 (フルカラー機) に設置する場合 >
 305JP34070 と印刷されている JATE ラベル (G) を貼り付ける。

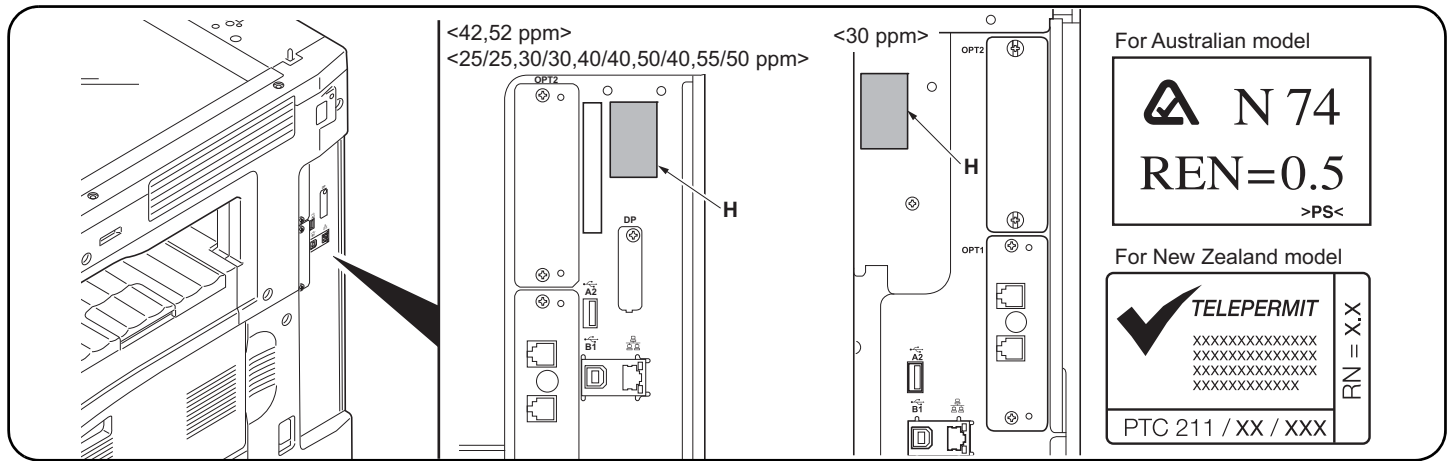

Attach the approval label (for Australian/New Zealand model only).

12. Attach the approval label (H) after wiping with alcohol.
Perform this procedure for Australian/New Zealand model only.

When installing the optional Dual FAX (when adding the FAX circuit board to OPT2), proceed to the following procedures.

When not installing, proceed to page 14.

Install the Dual FAX

Refer to page 1 for the supplied parts. When installing the optional Dual FAX, the approval label (H) is not required. Bring back and discard it.

Fixer l'étiquette d'approbation (modèle pour l'Australie/Nouvelle-Zélande seulement).

12. Effectuer cette procédure pour le modèle pour l'Australie/Nouvelle-Zélande seulement.

Lorsqu'on installe le FAX double en option (lorsqu'on ajoute la carte à circuits FAX à l'OPT2), effectuer les procédures suivantes. Si on ne l'installe pas, passer à la page 14.

Installer le FAX double.

Pour plus de détails concernant les pièces fournies, se reporter à la page 1.

Coloque la etiqueta de aprobación (sólo para los modelos Australiano/Nuevo Zelandés)

12. Realice este procedimiento sólo para los modelos Australiano/Nuevo Zelandés.

Cuando instale el FAX dual opcional (cuando agrega la tarjeta de circuitos de FAX a OPT2), vaya a los siguientes procedimientos. Cuando no lo instala, vaya a la página 14.

Instale el FAX dual

Consulte la página 1 de las piezas suministradas.

Den Genehmigungsaufkleber anbringen (nur für Australien/Neuseeland-Modell).

12. Dieses Verfahren nur für das Australien/Neuseeland-Modell anwenden.

Wenn das optionale Dual FAX installiert wird (Hinzufügen der FAX-Leiterplatte zu OPT2), mit den folgenden Verfahren fortfahren. Erfolgt diese Installation nicht, mit Seite 14 fortfahren.

Installieren des Dual FAX

Die mitgelieferten Teile sind auf Seite 1 aufgelistet.

Applicare l'etichetta di approvazione (solo per il modello Australia/Nuova Zelanda).

12. Eseguire questa procedura solo per il modello Australia/Nuova Zelanda.

Quando si installa il Dual FAX opzionale (quando si aggiunge la scheda a circuiti FAX all'OPT2), continuare con la seguente procedura. Se non si esegue l'installazione passare alla pagina 14.

Installare il Dual FAX

Fare riferimento alla pagina 1 per le parti in dotazione.

粘貼规格标签 (仅适用于澳大利亚 / 新西兰型号)

12. 该步骤仅适用于澳大利亚 / 新西兰型号时操作。

安装选购件的多插口组件时 (将传真电路板安装在 OPT2 上时), 请按以下步骤进行。不安装时, 按第 14 页的要求进行操作。

安装多插口组件

附属品时, 参照第 1 页。

规格标签的贴附 (オーストラリア / ニュージーランド仕様のみ)

12. この手順はオーストラリア / ニュージーランド仕様のみおこなう。

オプションのマルチポートを設置する場合 (FAX 基板を OPT2 に増設する場合は、次の手順に進む。設置しない場合は、14 ページへ進む。

マルチポートの設置

同梱品は 1 ページを参照する。マルチポート設置の場合、JATE ラベル (G) は不要のため、持ち帰り廃棄すること。

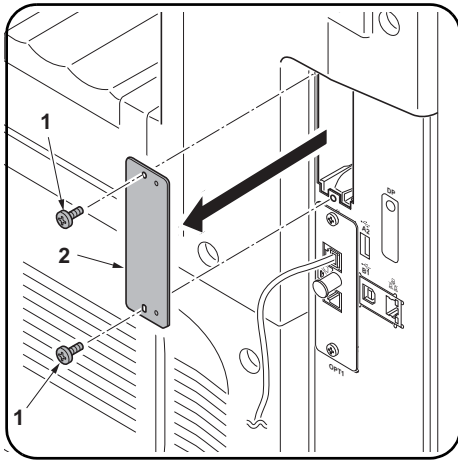

Remove the cover.

1. Remove two screws (1) and then remove OPT2 cover (2).

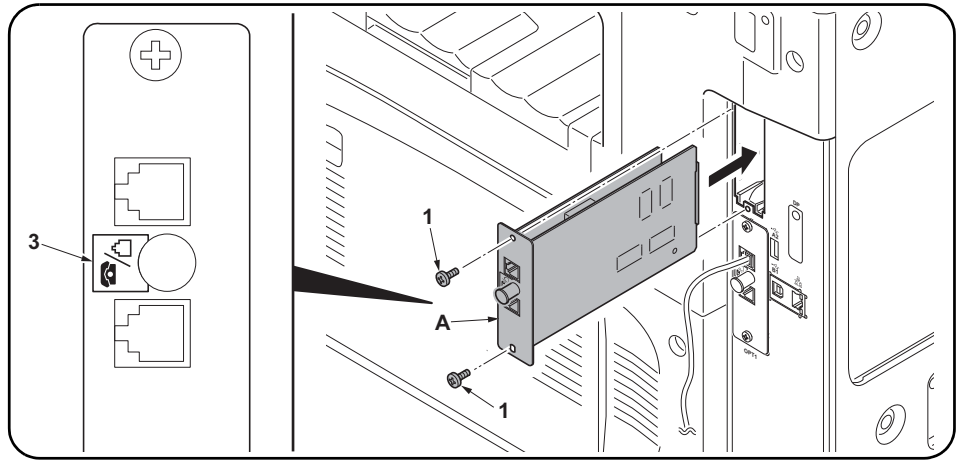

Install the FAX circuit board.

2. Insert the FAX circuit board (A) along the groove in OPT2 and secure the board with two screws (1) that have been removed in step 1.

Do not directly touch the FAX circuit board (A) terminal. Hold the top and bottom of the FAX circuit board, or the projection of the board to insert the FAX circuit board (A). Direct the label (3) on to the FAX circuit board (A) toward left side and insert the board along the groove.

Retirer le couvercle.

1. Retirer les deux vis (1), puis le couvercle OPT2 (2).

Installer la carte à circuits FAX.

2. Insérer la carte à circuits FAX (A) le long de la rainure dans l'OPT2 et la fixer à l'aide des deux vis (1) retirées à l'étape 1.

Ne pas toucher directement la borne de la carte à circuits FAX (A). Tenir les parties inférieure et supérieure de la carte à circuits FAX ou la saillie de la carte pour insérer la carte à circuits FAX (A). Orienter l'étiquette (3) de la carte à circuits FAX (A) comme illustré et insérer la plaquette le long de la rainure.

Desmonte la cubierta.

1. Quite dos tornillos (1) y desmonte la cubierta OPT2 (2).

Instale la tarjeta de circuitos de fax.

2. Inserte la tarjeta de circuitos de fax (A) a lo largo de la ranura de OPT2 y asegúrela con los dos tornillos (1) que ha quitado en el paso 1.

No toque directamente el terminal de la tarjeta de circuitos del fax (A). Sujete las partes superior e inferior de la tarjeta de circuitos de fax o la saliente de la tarjeta para insertar la tarjeta de circuitos de fax (A). Oriente la etiqueta (3) en la tarjeta de circuitos del FAX (A) como se indica en la ilustración e inserte la tarjeta a lo largo de la ranura.

Entfernen der Abdeckung.

1. Die beiden Schrauben (1) herausdrehen und Abdeckung OPT2 (2) abnehmen.

Installieren der FAX-Leiterplatte.

2. FAX-Leiterplatte (A) in die Nut des Einbauschachts OPT2 einsetzen und Leiterplatte mit den in Schritt 1 ausgebauten Schrauben (1) befestigen.

Berühren Sie die Anschlüsse der FAX-Platine (A) nicht mit den Fingern. Die FAX-Leiterplatte (A) beim Einsetzen oben und unten oder an dem Vorsprung festhalten. Die FAX-Leiterplatte (A) so in die Nut einsetzen, dass der Aufkleber (3) wie abgebildet zur Leiterplatte zeigt.

Rimuovere il coperchio.

1. Rimuovere le due viti (1), quindi rimuovere il coperchio OPT2 (2).

Installare la scheda a circuiti FAX.

2. Inserire la scheda a circuiti FAX (A) lungo l'incavo nell'OPT2 e fissare la scheda con le due viti (1) rimosse nell'operazione 1.

Non toccare direttamente il terminale della scheda a circuiti FAX (A), tenere l'estremità superiore e la base della scheda a circuiti FAX, o la sporgenza della scheda a circuiti FAX. Orientare l'etichetta (3) sulla scheda a circuiti FAX (A) come indicato nell'illustrazione e inserire la scheda lungo l'incavo.

拆下盖板

1. 拆下 2 顆螺釘 (1)，然後拆下 OPT2 盖板 (2)。

安裝傳真電路板

2. 沿著 OPT2 的溝槽插入傳真電路板 (A) 並用在步驟 1 中拆下的兩顆螺釘 (1) 固定電路板。

不要觸碰傳真電路板 (A) 端子。按住傳真電路板的頂部和底部，或者按住電路板的突出部將傳真電路板 (A) 插入。將標籤 (3) 放在傳真電路板 (A) 上，朝向左側，然後沿著溝槽插入電路板。

カバーの取り外し

1. ビス (1) 2 本を外し、OPT2 のカバー (2) を取り外す。

FAX 基板の取り付け

2. OPT2 の溝に沿って FAX 基板 (A) を挿入し、手順 1 で外したビス (1) 2 本で固定する。

FAX 基板 (A) の端子に直接触れないこと。FAX 基板 (A) の挿入時は基板の上下か突起を持つこと。FAX 基板 (A) は、貼り付けられているラベル (3) が図に示す方向になるように、挿入すること。

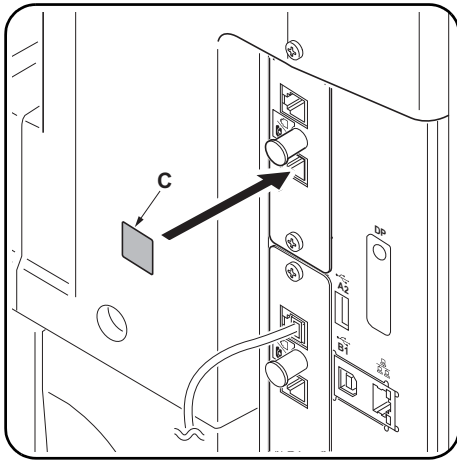

Seal the terminal.

3. Wipe the surface of the telephone terminal with alcohol and adhere the terminal seal (C).
The telephone terminal on the FAX circuit board installed to OPT2 is unavailable (invalid). Seal the terminal securely to prevent a user from connecting a separate phone.

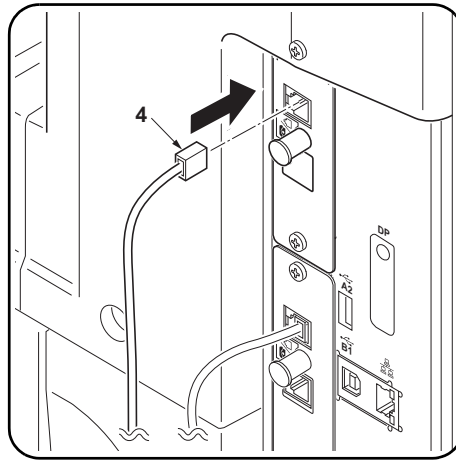

Connect the MFP to the telephone line.

4. Plug the modular connector cable (4) into the line terminal, and then connect the other end to the telephone line.
For 100 V/120 V/Australian or Chinese models, use the supplied modular connector cable (B).

Fermer hermétiquement la borne.

3. Nettoyer la surface de la borne de téléphone avec de l'alcool, et apposer le joint de borne (C).
La borne de téléphone de la carte à circuits FAX installée sur l'OPT2 n'est pas utilisable (invalid). Fermer hermétiquement la borne pour empêcher tout utilisateur de connecter un téléphone séparé.

Connecter le MFP à la ligne de téléphone.

4. Brancher le câble du connecteur modulaire (4) à la borne de la ligne, puis connecter l'autre extrémité à la ligne de téléphone.
Pour les modèles 100 V/120 V/Australie ou Chine, utilisez le câble à connecteur modulaire (B) fourni.

Selle el terminal.

3. Limpie la superficie del terminal de teléfono con alcohol y pegue el sello de terminal (C).
El terminal de teléfono de la tarjeta de circuitos de FAX instalada en el OPT2 no está disponible (inválido). Selle firmemente el terminal para evitar que un usuario conecte un teléfono por separado.

Conecte el MFP a la línea telefónica.

4. Enchufe el cable del conector modular (4) en el terminal de línea y, a continuación, conecte el otro extremo a la línea telefónica.
Para los modelos de 100 V/120 V/Australiano o Chino, utilice el cable conector modular (B) suministrado.

Versiegeln der Anschlussbuchse.

3. Die Oberfläche der Telefonanschlussbuchse mit Alkohol abwischen und die Verschlusskappe (C) anbringen.
Die Telefonanschlussbuchse der in OPT2 installierten FAX-Leiterplatte ist nicht verfügbar (ungültig). Die Anschlussbuchse vollkommen versiegeln, um den Anschluss eines separaten Telefons zu verhindern.

Anschließen des MFP an die Telefonleitung.

4. Telefonmodulkabel (4) in die Gerätebuchse einstecken und das Kabel an der Telefondose anschließen.
Das mitgelieferte Modularsteckerkabel (B) für die 100-V/120-V/Australien- oder China-Modelle verwenden.

Sigillare il terminale.

3. Pulire la superficie del terminale del telefono con alcol e fare aderire la guarnizione terminale (C).
Il terminale del telefono sulla scheda a circuiti FAX installata su OPT2 non è disponibile (invalido). Sigillare il terminale saldamente per prevenire a un utente di collegare un telefono separato.

Collegamento dell'MFP alla linea del telefono.

4. Inserire il cavo connettore modulare (4) nel terminale della linea, e quindi collegare l'altro terminale alla linea del telefono.
Per modelli da 100 V/120 V/Australia o Cina, utilizzare il cavo connettore modulare (B) in dotazione.

安装端子密封

3. 用酒精擦拭电话端子表面并粘上端子密封 (C)。
安装在 OPT2 上的传真电路板的电话端子不可使用 (无效)。为了避免用户错误与其它电话连接, 必须确实粘贴好端子密封。

将 MFP 连接到电话线

4. 将模块接插件电缆 (4) 插入电话线端子, 然后将另一端与电话线连接。
对于 100 V/120 V / 澳大利亚或中国机型, 请使用随附的模块接插件电缆 (B)。

端子シールの貼り付け

3. TEL 端子周囲をアルコール清掃し、端子シール (C) を貼り付ける。
OPT2 に取り付けられた FAX 基板の TEL 端子は使用不可 (無効) となる。ユーザが誤って外付け電話を接続しないよう確実に貼り付けること。

電話回線との接続

4. モジュラコード (4) をライン端子に差し込む。もう片方のプラグは、電話回線へ接続する。
100V/120V/ オーストラリア仕様 / 中国仕様は付属のモジュラコード (B) を使用すること。

Initialize the FAX circuit board.

1. Plug the MFP into a power outlet, and turn on the main power.
2. If the FAX circuit board has been installed only in OPT1 or installed both in OPT1 and OPT2 (to initialize all FAX circuit boards) Perform the maintenance mode U600 to initialize the fax control assembly.

3. If the FAX circuit board has been added to OPT2 (to initialize the FAX circuit board in OPT2) Initialize OPT2 by pressing [PORT2], and the Start key in this order in the maintenance mode U698 and executing the maintenance mode U600.

If [ALL] is selected in U698, both OPT1 and OPT2 are initialized.
For details, see the service manual.
Refer to the operation guide to create a FAX Box.

Initialiser la carte à circuits FAX.

1. Brancher le MFP sur une prise d'alimentation et le mettre sous tension.
2. Si la carte à circuits FAX a été installée dans l'OPT1 seulement, ou a été installée dans l'OPT1 et dans l'OPT2 (pour initialiser toutes les cartes à circuits FAX) Exécuter le mode de maintenance U600 pour initialiser l'ensemble de commande de fax.

3. Si la carte à circuits FAX a été ajoutée à l'OPT2 (pour initialiser la carte à circuits FAX dans l'OPT2) Initialiser l'OPT2 en appuyant sur [PORT2] et la touche Départ dans cet ordre en mode de maintenance U698, et exécuter le mode de maintenance U600.

Si [ALL] est sélectionné dans U698, l'OPT1 et l'OPT2 sont tous deux initialisés.
Pour plus de détails, se reporter au manuel d'entretien.
Se reporter au manuel d'utilisation pour créer une Boîte de FAX.

Inicialice la tarjeta de circuitos FAX.

1. Conecte el MFP a un receptáculo de pared y encienda el interruptor principal.
2. Si la tarjeta de circuitos de FAX se instaló solo en OPT1 o se instaló tanto en OPT1 como OPT2 (para inicializar todas las tarjetas de circuito de FAX) Ejecute el modo de mantenimiento U600 para inicializar el conjunto de control de fax.

3. Si la tarjeta de circuitos de FAX se agregó a OPT2 (para inicializar la tarjeta de circuitos de FAX en OPT2) Inicialice el OPT2 presionando [PORT2] y la tecla de Inicio en ese orden en el modo de mantenimiento U698 y ejecutando el modo de mantenimiento U600.

Si se selecciona [ALL] en U698, se inicializan ambos OPT1 y OPT2.
Para más detalles, lea el manual de servicio.
Consulte la guía de uso para crear un Buzón de FAX.

Initialisieren der FAX-Leiterplatte.

1. Netzstecker des MFP in eine Steckdose stecken und Hauptschalter einschalten.
2. Wenn die FAX-Leiterplatte nur in OPT1 oder sowohl in OPT1 als auch in OPT2 installiert worden ist (um alle FAX-Leiterplatten zu initialisieren) Wartungsmodus U600 ausführen, um die Faxsteuerbaugruppe zu initialisieren.

3. Wenn die FAX-Leiterplatte zu OPT2 hinzugefügt worden ist (um die FAX-Leiterplatte in OPT2 zu initialisieren) OPT2 initialisieren. Dazu [PORT2] und die Start-Taste im Wartungsmodus U698 in dieser Reihenfolge drücken und den Wartungsmodus U600 ausführen.

Wenn [ALL] in U698 gewählt wird, werden OPT1 und OPT2 initialisiert.
Weitere Einzelheiten siehe Wartungsanleitung.
Schlagen Sie zur Erzeugung einer FAX-Box in der Einführung nach.

Inizializzare la scheda a circuiti FAX.

1. Collegare l'MFP ad una presa di corrente e portare l'interruttore principale su On.
2. Se la scheda a circuiti FAX è stata installata solo nell'OPT1 o in entrambi l'OPT1 e l'OPT2 (per inizializzare tutte le schede di circuito FAX) Eseguire il modo di manutenzione U600 per inizializzare il gruppo di controllo fax.

3. Se la scheda a circuiti è stata aggiunta all'OPT2 (per inizializzare la scheda a circuiti FAX nell'OPT2) Inizializzare OPT2 premendo [PORT2] e il tasto Avvio in questo ordine nel modo di manutenzione U698 ed eseguendo il modo di manutenzione U600.

Se viene selezionato [ALL] nel modo U698, entrambi OPT1 e OPT2 sono inizializzati.
Per ulteriori dettagli leggere il manuale d'istruzioni.
Leggere la guida alle funzioni per creare una Casella FAX.

传真电话板的初始化

1. 将 MFP 插入电源插座，打开主电源。
2. 仅限于在 OPT1 或 OPT1 和 OPT2 上同时安装传真电路板时（全部的传真电路板初始化）执行维修保养模式 U600，初始化传真控制组件。

3. 在 OPT2 上增设时（OPT2 的传真电路板初始化）只进行 OPT2 初始化时，在维修保养模式 U698 状态下，按顺序按下“PORT2”、开始键，执行维修保养模式 U600。

在 U698 状态下设定“ALL”时，会使 OPT1 和 OPT2 均初始化。
有关详细信息，请参见维修手册。
参照操作手册，作成传真盒。

FAX 基板の初期化

1. MFP 本体の電源プラグをコンセントに差し込み、主電源スイッチを ON にする。
2. OPT1 のみまたは OPT1 と OPT2 に FAX 基板を同時に設置した場合（すべての FAX 基板を初期化）メンテナンスモード U600 を実行し、FAX 基板を初期化する。

3. OPT2 に増設した場合（OPT2 の FAX 基板を初期化）メンテナンスモード U698 で「PORT2」、スタートキーの順に押す。メンテナンスモード U600 を実行し、FAX 基板を初期化する。

U698 で「ALL」を設定すると OPT1 と OPT2 両方を初期化するので注意すること。
詳細はサービスマニュアルを参照のこと。
使用説明書を参照し、ファクスボックスを作成する。

KYOCERA MITA EUROPE B.V.

Hoeksteen 40, 2132 MS Hoofddorp,
The Netherlands
Phone: +31.20.654.0000
Home page: <http://www.kyoceramita-europe.com>
Email: info@kyoceramita-europe.com

KYOCERA MITA NEDERLAND B.V.
Beechavenue 25, 1119RA Schiphol-Rijk
The Netherlands
Phone: +31.20.58.77.200

KYOCERA MITA (UK) LTD
8 Beacontree Plaza
Gillette Way Reading Berks RG2 OBS,
U.K.
Phone: +44.1189.311.500

KYOCERA MITA ITALIA S.p.A.
Via G. Verdi, 89 / 91, 20063 Cernusco s/N
Milano, Italy
Phone: +39.02.92179.1

S.A. KYOCERA MITA BELGIUM N.V.
Hermesstraat 8A, 1930 Zaventem,
Belgium
Phone: +32.2.720.9270

KYOCERA MITA FRANCE S.A.
Parc Les Algorithmes Saint Aubin
91194 GIF-SUR-YVETTE,
France
Phone: +33.1.6985.2600

KYOCERA MITA ESPAÑA S.A.
Edificio Kyocera, Avda de Manacor No. 2,
28290 Las Matas (Madrid),
Spain
Phone: +34.91.631.8392

KYOCERA MITA FINLAND OY
Kirvesmiehenkatu 4, 00880 Helsinki,
Finland
Phone: +358.9.4780.5200

KYOCERA MITA (SCHWEIZ)
Hohlstrasse 614, 8048 Zürich
Switzerland
Phone: +41.1.908.4949

KYOCERA MITA DEUTSCHLAND GMBH
Otto-Hahn-Str. 12 D-40670 Meerbusch,
Germany
Phone: +49.2159.918.0

KYOCERA MITA GMBH AUSTRIA
Eduard-Kittenberger-Gasse 95,
1230 Wien,
Austria
Phone: +43.1.86338.210

KYOCERA MITA SVENSKA AB
Esbogatan 16B 164 75 Kista,
Sweden
Phone: +46.8.546.55000

KYOCERA MITA NORGE
Postboks 150 Oppsal, NO 0619 Oslo
Olaf Helsetsvvei 6, NO 0694 Oslo,
Norway
Phone: +47.22.62.73.00

KYOCERA MITA DANMARK A/S
Ejby Industrivej 1, DK-2600 Glostrup,
Denmark
Phone: +45.5687.1100

KYOCERA MITA PORTUGAL LDA.
Rua do Centro Cultural, 41 (Alvalade) 1700-106 Lisbon,
Portugal
Phone: +351.21.842.9100

KYOCERA MITA SOUTH AFRICA (PTY) LTD.
527 Kyalami Boulevard,
Kyalami Business Park Midrand,
South Africa
Phone: +27.(0)11.540.2600

KYOCERA MITA AMERICA, INC.

Headquarters:
225 Sand Road,
Fairfield, New Jersey 07004-0008,
U.S.A.
Phone: (973) 808-8444

KYOCERA MITA AUSTRALIA PTY. LTD.
Level 3, 6-10 Talavera Road, North Ryde,
N.S.W. 2113 Australia
Phone: (02) 9888-9999

KYOCERA MITA NEW ZEALAND LTD.
1-3 Parkhead Place, Albany
P.O. Box 302 125 NHPC, Auckland,
New Zealand
Phone: (09) 415-4517

KYOCERA MITA (THAILAND) CORP., LTD.
9/209 Ratchada-Prachachem Road,
Bang Sue, Bangkok 10800, Thailand
Phone: (02) 586-0320

KYOCERA MITA SINGAPORE PTE LTD.
121 Genting Lane, 3rd Level,
Singapore 349572
Phone: 67418733

KYOCERA MITA HONG KONG LIMITED
11/F., Mita Centre,
552-566, Castle Peak Road,
Tsuen Wan, New Territories,
Hong Kong
Phone: 24297422

KYOCERA MITA TAIWAN Corporation.
7F-1~2, No.41, Lane 221, Gangchi Rd.
Neihu District, Taipei, Taiwan, 114. R.O.C.
Phone: (02) 87511560

KYOCERA MITA Corporation

2-28, 1-chome, Tamatsukuri, Chuo-ku
Osaka 540-8585, Japan
Phone: (06) 6764-3555
<http://www.kyoceramita.com>

KYOCERA MITA AMERICA, INC.

Headquarters:

225 Sand Road,
Fairfield, New Jersey 07004-0008
TEL : (973) 808-8444
FAX : (973) 882-6000

New York Branch:

1410 Broadway 23rd floor
New York, NY 10018
TEL : (917) 286-5400
FAX : (917) 286-5402

Northeastern Region:

225 Sand Road,
Fairfield, New Jersey 07004-0008
TEL : (973) 808-8444
FAX : (973) 882-4401

Midwestern Region:

201 Hansen Court Suite 119
Wood Dale, Illinois 60191
TEL : (630) 238-9982
FAX : (630) 238-9487

Western Region:

14101 Alton Parkway,
Irvine, California 92618-7006
TEL : (949) 457-9000
FAX : (949) 457-9119

Southeastern Region:

1500 Oakbrook Drive,
Norcross, Georgia 30093
TEL : (770) 729-9786
FAX : (770) 729-9873

Southwestern Region:

2825 West Story Road,
Irving, Texas 75038-5299
TEL : (972) 550-8987
FAX : (972) 252-9786

National Operation Center & National Training Center:

2825 West Story Road,
Irving, Texas 75038-5299
TEL : (972) 659-0055
FAX : (972) 570-5816

Latin America Division:

8240 N.W. 52nd. Terrace Dawson Building,
Suite 108 Miami, Florida 33166
TEL : (305) 421-6640
FAX : (305) 421-6666

KYOCERA MITA CANADA, LTD.

6120 Kestrel Road, Mississauga,
Ontario L5T 1S8, Canada
TEL : (905) 670-4425
FAX : (905) 670-8116

KYOCERA MITA MEXICO, S.A. DE C.V.

Av. 16 de Septiembre #407
Col. Santa Inés,
Azcapotzalco México,
D.F. 02130, México
TEL : (55) 5383-2741
FAX : (55) 5383-7804

©2010 KYOCERA MITA Corporation

<http://www.kyoceramita.com>

 **KYOCERA** is a trademark of Kyocera Corporation

Printed in U.S.A.