



FS-C5020N FS-C5030N

PARTS LIST

Published in May 2008
2F3PL078
Rev.8

NOTES

1. Indicate parts number and machine model when placing an order.

eg.	Parts Number	Parts Name	Machine Model	Cycle	Quantity
	302F300870	BRACKET HV ASSY (16 PPM)	FS-C5020N	60Hz / 50Hz	1
	302F400490	BRACKET HV ASSY (24 PPM)	FS-C5030N	60Hz / 50Hz	1

2. Service calls and freight will be charged separately.

3. Symbols in the "Parts Number" column.

- Parts with "•" are component parts or sub-assemblies of the assembly appearing immediately above them.

eg.	Parts Number	Parts Name	Parts Number	Parts Name
	302F300830	COVER TOP ASSY	•5MVB986SH026	COVER TOP
			•5MMW251LD046	SPRING PULLEY

- Parts with "••" are component parts or sub-assembly with "•" appearing immediately above them.

eg.	Parts Number	Parts Name	Parts Number	Parts Name
	•5AAYA37E++35	HOLDER FEED ASSY	••5MVX642DH001	COVER BKT FEED
			••5MVG137DN036	GEAR FEED IDLE Z29S

- Parts with "⊙" indicates the spare parts and the parts without "⊙" can not be supplied.

— CONTENTS —

FIG. 1	Exterior Covers	2
FIG. 2	Upper Frame Unit	4
FIG. 3	Drive Units	6
FIG. 4	Controller Box	8
FIG. 5	Paper Feed Unit	10
FIG. 6	Fuser Unit (16 PPM)	12
FIG. 6	Fuser Unit (24 PPM)	14
FIG. 7	Drum Unit / LED Unit	16
FIG. 8	Developer Unit	18
FIG. 9	Frame MP Assembly	20
FIG. 10	MP Tray	22
FIG. 11	Primary Transfer Unit	24
FIG. 12	Paper Cassette	26
FIG. 13	Accessories	28
FIG. 14	Packing Assemblies	30
	• INDEX	31

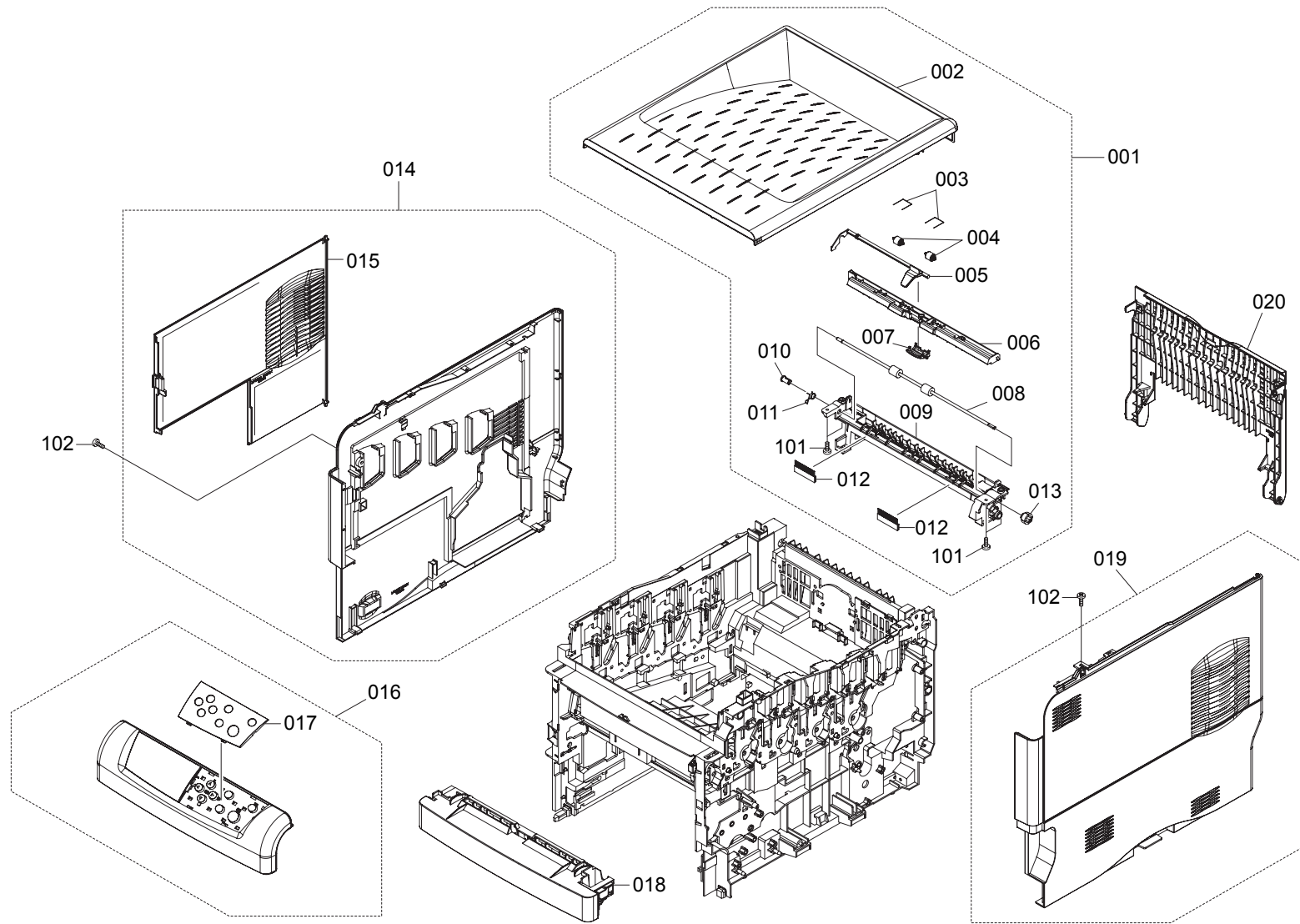

FIG. 1 Exterior Covers

2F3/2F4-6.0

SP	Ref. No.	Part.No.	Alternative.	Description	Quantity		
					110	120	230
⊙	001	302F300830	2F300830	COVER TOP ASSY	1	1	1
⊙	002	*5MVB986SH026	2D904010	COVER TOP	1	1	1
⊙	003	*5MMW251LD046	2BS04050	SPRING PULLEY	2	2	2
⊙	004	*5MVM273DB006	2BS04170	ROLLER PINCH	2	2	2
⊙	005	*5MVX732CB003	2BS04310	ACTUATOR FD	1	1	1
⊙	006	*5MVX852CH002	2BS04340	FRAME FD	1	1	1
⊙	007	*5MVX332DB015	2D904170	GUIDE STOCK	1	1	1
⊙	008	*302F304020	2F304020	ROLLER FD	1	1	1
⊙	009	*5MVX866XB003	2D904060	FRAME FD LOW	1	1	1
⊙	010	*5MVM266DN006	2BS02290	BUSH FD	1	1	1
⊙	011	*5MMW463LD001	2D902570	SPRING FD LOW	1	1	1
⊙	012	*302F304030	2F304030	DISCHARGER FD	2	2	2
⊙	013	*5MVG127DN076	2BS02220	GEAR ROLL FD Z18	1	1	1
⊙	014	302F300370	2F300370	COVER LEFT ASSY	1	1	1
⊙	015	*302D904042	2D904042	COVER SIDE	1	1	1
⊙	016	302F300330	2F300330	KEY BOARD ASSY (16 PPM) (Excl. KMFR/KMIT)	1	1	1
⊙	016	302F400170	2F400170	KEY BOARD ASSY (24 PPM) (Excl. KMFR/KMIT)	1	1	1
⊙	016	302F300340	2F300340	KEY BOARD ASSY (16 PPM) (KMFR only)	1	1	1
⊙	016	302F400180	2F400180	KEY BOARD ASSY (24 PPM) (KMFR only)	1	1	1
⊙	016	302F300350	2F300350	KEY BOARD ASSY (16 PPM) (KMIT only)	1	1	1
⊙	016	302F400190	2F400190	KEY BOARD ASSY (24 PPM) (KMIT only)	1	1	1
⊙	016	302F300A60	2F300A60	KEY BOARD ASSY (16 PPM) (KMTW)	1	1	1
⊙	016	302F400570	2F400570	KEY BOARD ASSY (24 PPM) (KMTW)	1	1	1
⊙	017	*5MVB761SH013	2D904100	COVER PANEL FRENCH (KMFR only)	1	1	1
⊙	017	*5MVB761SH014	2D904110	COVER OABEL ITALIAN (KMIT only)	1	1	1
⊙	017	*302D924061	2D924061	COVER PANEL E (Excl. KMFR/KMIT)	1	1	1
⊙	017	*302D904301	2D904301	COVER PANEL TW (KMTW)	1	1	1
⊙	018	5MVB866CH022	2BS04110	COVER FRONT	1	1	1
⊙	019	302F300390	2F300390	COVER RIGHT ASSY	1	1	1
⊙	020	302D904051	2D904051	COVER REAR	1	1	1

SP	Ref. No.	Part.No.	Alternative.	Description	Quantity		
					110	120	230
	101	5MBTPB3010PW++R	B1B63100	BIND T.T SCREW(+) / M3 X 10 CRFREE P-T			
	102	5MBTPB4010PW++R	B1A64100	BIND T.T SCREW(+) / M4 X 10 CRFREE P-T			

- Parts with "*" are component parts or sub-assemblies of the assembly appearing immediately above them.
- Parts with "⊙" indicates the spare parts.

- Parts with ". ." are component parts or sub-assembly with ". ." appearing immediately above them.

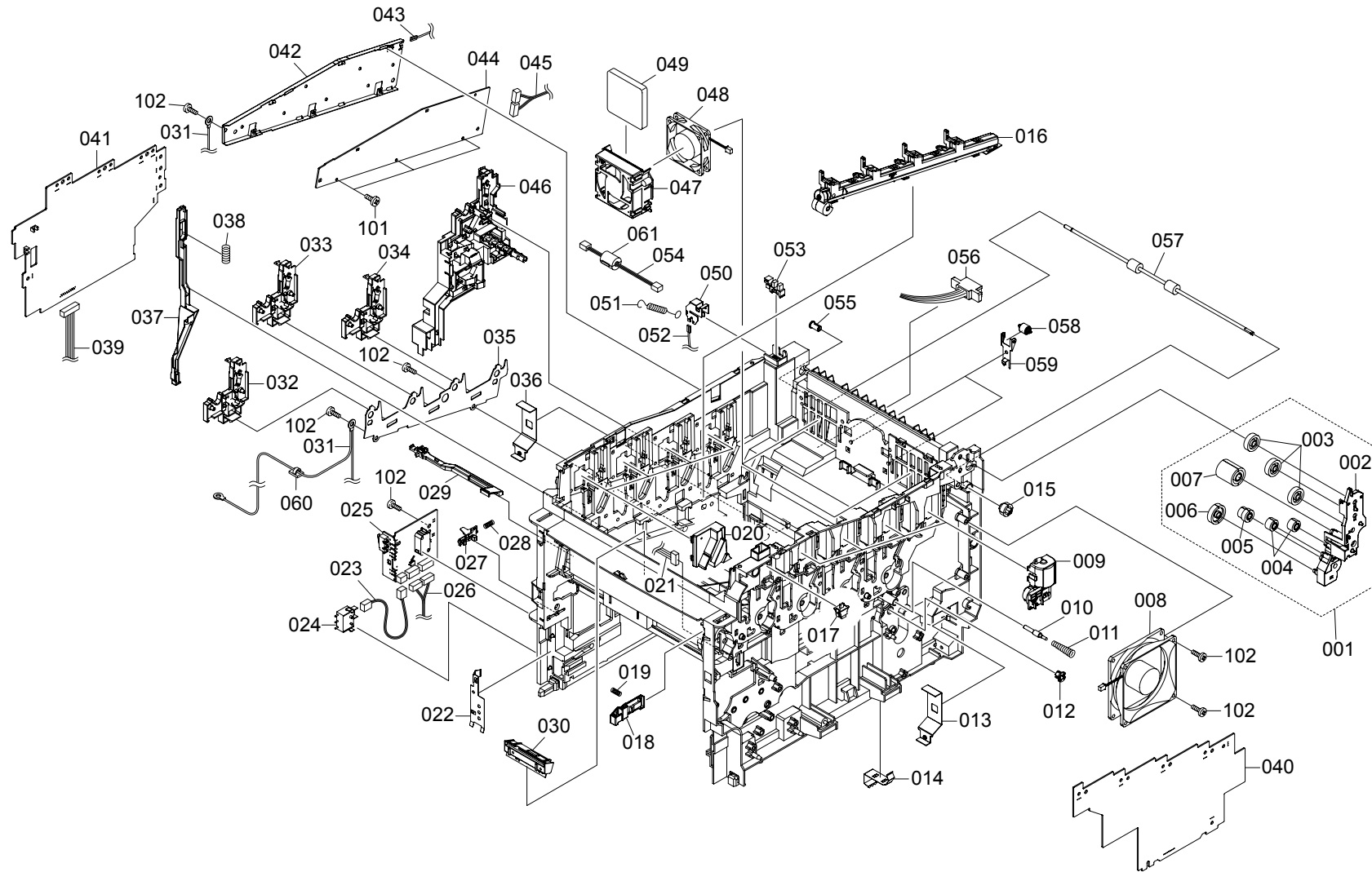

FIG. 2 Upper Frame Unit

2F3/2F4-8

SP	Ref. No.	Part.No.	Alternative.	Description	Quantity		
					110	120	230
⊙	001	302F300890	2F300890	BRACKET FD GEAR ASSY	1	1	1
⊙	002	*302D902391	2D902391	BRACKET FD GEAR	1	1	1
⊙	003	*5MVG137DN014	2BS02240	GEAR IDLE Z25	3	3	3
⊙	004	*2B720380	5MVG127DW004	GEAR IDLE Z16	2	2	2
⊙	005	*5MVG127DN122	2D902400	GEAR FD Z15-Z18	1	1	1
⊙	006	*5MVG138DN048	2BD02270	GEAR FD Z29	1	1	1
⊙	007	*5MVG138DN047	2BS02260	GEAR FD Z28	1	1	1
⊙	008	302F344010	2F344010	FAN MOTOR	1	1	1
⊙	009	302F300441	2F300441	TONER MOTOR ASSY	4	4	4
	010	302F302030	2F302030	PIN CONTACT BIAS	1	1	1
	011	5MMW222LD003	2D902580	SPRING CONTACT CLN	1	1	1
⊙	012	5MVM176DN035	2D922250	BUSH FRAME	1	1	1
	013	5MMX632SD006	2D902380	PLATE EARTH FUSER	1	1	1
	014	5MMZ242LD002	2D902330	PLATE EARTH HV B	1	1	1
⊙	015	5MVG127DN076	2BS02220	GEAR ROLL FD Z18	1	1	1
⊙	016	302F300430	2F300430	WASTE TONER ASSY	1	1	1
⊙	017	5ESP01000101+01	SP000310	PUSH SWITCH 01 SN	1	1	1
	018	5MVX522DB006	2BS02390	LOCK COVER M/P	1	1	1
	019	5MMW261LD051	2BR02340	SP LOCK COVER M/P	1	1	1
	020	302D902372	2D902372	COVER HARNESS	4	4	4
	021	5AACCNSR4GEA++P	2D926260	CONN. CORD ASSY S02877	1	1	1
	022	5MMS632LD001	2D902320	PLATE EARTH HV A	1	1	1
	023	5AACCNSN7GEA++P	2D926160	CONN. CORD ASSY S02861	1	1	1
⊙	024	5FSP03090001+01	SP0A0360	PUSH SWITCH 03 SN	1	1	1
⊙	025	302F301320	2F301320	P.W.BOARD ASSY SENSOR	1	1	1
	026	5AACCNSM5GEA++P	2D926060	CONN. CORD ASSY S02849	1	1	1
	027	5MVX322DB023	2BS02350	LEVER EF	1	1	1
	028	5MMW222LD002	2BR02280	SPRING LEVER EF	1	1	1
⊙	029	5AAYA80E++75	2D969860	CLEANER ID ASSY	1	1	1
⊙	030	302F300410	2F300410	SENSOR ID ASSY	1	1	1
⊙	031	5AACCNS8GEA++P	2D926280	CONN. CORD ASSY S02975	1	1	1
⊙	032	5AAYA80E++71	2D969810	BRACKET HV DLP K ASSY	1	1	1
⊙	033	5AAYA80E++73	2D969830	BRACKET HV DLP Y ASSY	1	1	1
⊙	034	5AAYA80E++72	2D969820	BRACKET HV DLP C ASSY	1	1	1
	035	5MMS866SD001	2D908510	PLATE FRAME DRUM	1	1	1
	036	5MMX632SD006	2D902380	PLATE EARTH FUSER	1	1	1
	037	302D902311	2D902311	ROD INTERLOCK	1	1	1
	038	5MMW451LD001	2B700570	SPRING INTER LOCK	1	1	1
	039	5AACCNSM7GEA++P	2D926080	CONN. CORD ASSY S02851	1	1	1
⊙	040	302F345021	2F345021	TRANS ASSY HI VOLTAGE MAIN	1	1	1
⊙	041	302F345011	2F345011	TRANS ASSY HI VOLTAGE DLP	1	1	1
	042	5MMB861SD004	2D902200	PLATE SHIELD PWB	1	1	1
	043	5AACCNST1GEA++P	2D926310	CONN. CORD ASSY S02978	1	1	1
⊙	044	5AAPRIFR2018AHR	2F301120	P.W.B.ASSY KP-1091 LEDRLY B26 (16 PPM)	1	1	1
⊙	044	302F401300	2F401300	P.W.B.ASSY PA0008 LEDRLY (24 PPM)	1	1	1
	045	302F346140	2F346140	CONN. CORD ASSY S03113 (16 PPM)	1	1	1
	045	302F446020	2F446020	CONN.CORD ASSY S03109 (24 PPM)	1	1	1
⊙	046	302F300870	2F300870	BRACKET HV ASSY (16 PPM)	1	1	1
⊙	046	302F400490	2F400490	BRACKET HV ASSY (24 PPM)	1	1	1
⊙	046	302F400600	2F400600	BRACKET HV ASSY (24 PPM)	1	1	1

SP	Ref. No.	Part.No.	Alternative.	Description	Quantity		
					110	120	230
	047	302D902542	2D902542	BRACKET FAN	2	2	2
⊙	048	302F344030	2F344030	FAN MOTOR	2	2	2
⊙	049	5MVB661XF001	2D902530	OZONE FILTER	2	2	2
	050	5MMX332SD003	2D902550	PLATE EARTH FD	1	1	1
	051	302F302020	2F302020	SPRING EARTH FD	1	1	1
	052	302F346090	2F346090	CONN.CORD ASSY S03106 (16 PPM)	1	1	1
	052	5AACCNST2GEA++P	2D926320	CONN. CORD ASSY S02979 (24 PPM)	1	1	1
	052	302F446100	2F446100	CONN.CORD ASSY S03142 (24 PPM)	1	1	1
⊙	053	5HNXEESX1235+01	2D902860	PT.SENSOR EE-SX1235A	1	1	1
⊙	054	5AACCN5P6GEA++P	2D926240	CONN. CORD ASSY S02870	1	1	1
⊙	055	5MVM266DN006	2BS02290	BUSH FD	1	1	1
	056	5AACCN5N2GEA++P	2D926120	CONN. CORD ASSY S02856	1	1	1
⊙	057	302F302010	2F302010	ROLLER FD LOW	1	1	1
⊙	058	5MVM273DB006	2BS04170	ROLLER PINCH	2	2	2
	059	5MMX431LD017	2D902410	BRACKET ROLLER PINCH	2	2	2
	060	5MMX221SW002	3FW02530	CORD KEEP	1	1	1
	061	5EYBE1392700101	YB001900	FERRITE CORE	1	1	1
	101	5MBTPB3006TW++R	B1A53060	BIND T.T SCREW(+)/ M3 X 6 CRFREE S-T			
	102	5MBTPB4010PW++R	B1A64100	BIND T.T SCREW(+)/ M4 X 10 CRFREE P-T			

- Parts with "*" are component parts or sub-assemblies of the assembly appearing immediately above them.
- Parts with "⊙" indicates the spare parts.

- Parts with "••" are component parts or sub-assembly with "•" appearing immediately above them.

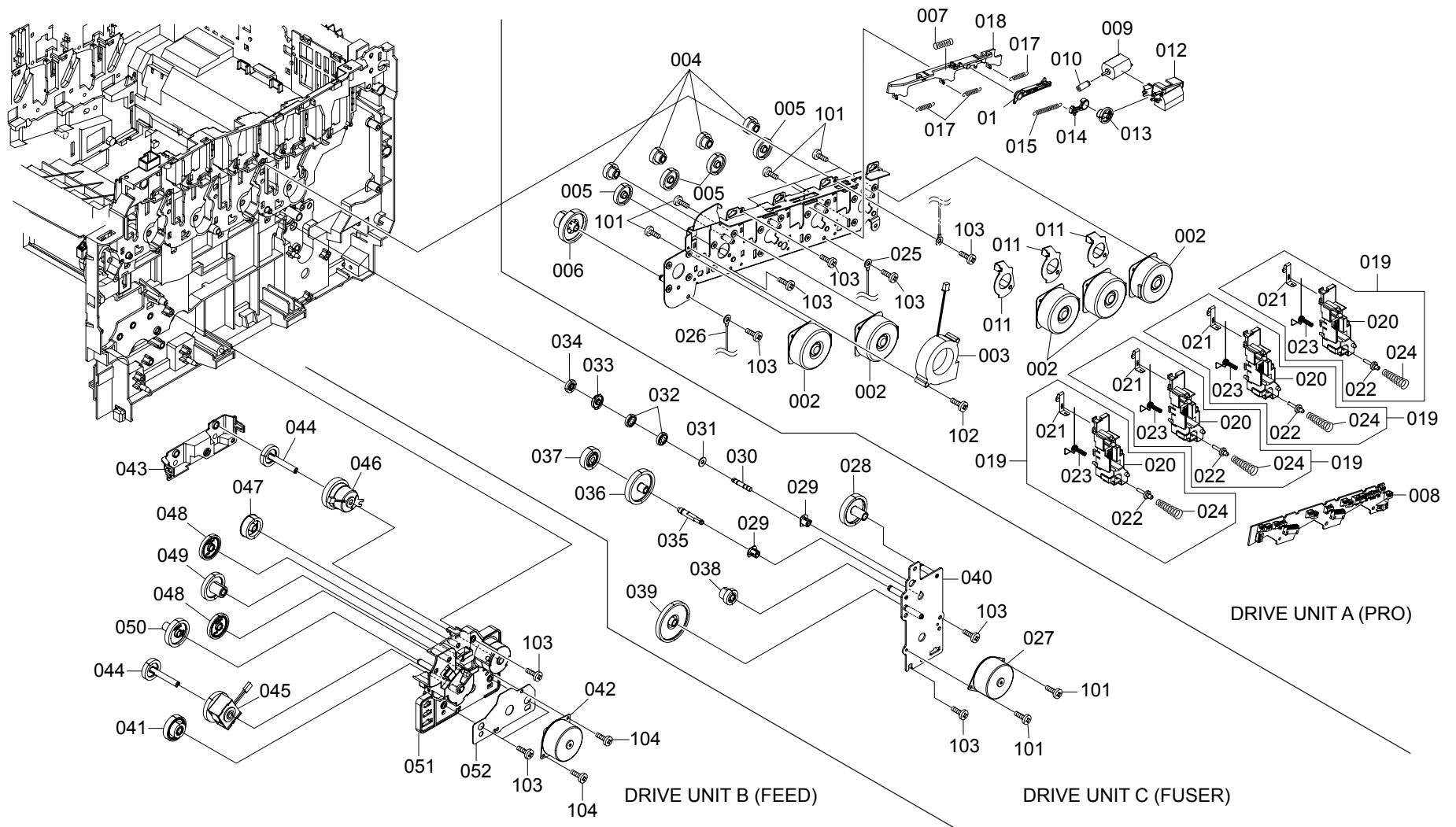

FIG. 3 Drive Units

2F3/2F4-6.0

SP	Ref. No.	Part.No.	Alternative.	Description	Quantity		
					110	120	230
⊙		302F393100	2F393100	DR-510A DRIVE PRO UNIT (16 PPM)	1	1	1
⊙		302F493030	2F493030	DR-520A DRIVE PRO UNIT (24 PPM)	1	1	1
⊙	001	*302F331010	2F331010	PLATE DRIVE MAIN	1	1	1
⊙	002	*302F331001	2F331001	STEPPING MOTOR PRO (16 PPM)	5	5	5
⊙	002	*302F431000	2F431000	STEPPING MOTOR PRO (24 PPM)	5	5	5
⊙	003	*302F344020	2F344020	FAN MOTOR	1	1	1
⊙	004	*302D922161	2D922161	GEAR Z21H-Z20H	4	4	4
⊙	005	*302F331022	2F331022	GEAR Z40H	4	4	4
⊙	006	*302D922181	2D922181	GEAR Z72H-Z22H	1	1	1
⊙	007	*302F331100	2F331100	SPRING LEVER	1	1	1
⊙	008	*302F301300	2F301300	P.W.B.ASSY KP1103 ENGRLY	1	1	1
⊙	009	*302F344040	2F344040	DC MOTOR	1	1	1
⊙	010	*5MVG115DB002	2BM14540	GEAR WORM	1	1	1
⊙	011	*302F331041	2F331041	PLATE IDLE ARM	3	3	3
⊙	012	*302F331030	2F331030	BRACKET MOTOR	1	1	1
⊙	013	*302F331060	2F331060	CAM GEAR Z34H	1	1	1
⊙	014	*302F331160	2F331160	HOOK CRANK	1	1	1
⊙	015	*302F331170	2F331170	SPRING HOOK CRANK	1	1	1
⊙	016	*302F331080	2F331080	LEVER CAM	1	1	1
⊙	017	*302F331090	2F331090	SPRING IDLE ARM	3	3	3
⊙	018	*302F331050	2F331050	LEVER PLATE IDLE	1	1	1
⊙	019	*302F300660	2F300660	BRACKET HV MAIN ASSY	4	4	4
⊙	020	**302F331150	2F331150	BRACKET HV MAIN	4	4	4
⊙	021	**302F331190	2F331190	CONTACT MAIN B	4	4	4
⊙	022	**302F331180	2F331180	PIN HV CONTACT	4	4	4
⊙	023	**302F331200	2F331200	SPRING HV MAIN	4	4	4
⊙	024	**5MMW311LD003	2B702130	SPRING HV CONTACT	4	4	4
⊙	025	5AACCNST4GEA++P	2D926340	CONN. CORD ASSY S02981	1	1	1
⊙	026	302F346080	2F346080	CONN. CORD ASSY	1	1	1
⊙		302F393120	2F393120	DR-510C DRIVE FUSER UNIT (16 PPM)	1	1	1
⊙		302F493050	2F493050	DR-520C DRIVE FUSER UNIT (24 PPM)	1	1	1
⊙	027	*5FZNT2400902+01	WNAA1170	STEPPING MOTOR FUSER (16 PPM)	1	1	1
⊙	027	*302F431010	2F431010	STEPPING MOTOR FUSER (24 PPM)	1	1	1
⊙	028	*302F331250	2F331250	GEAR Z43S (16 PPM)	1	1	1
⊙	028	*5MVG154BN001	2D922130	GEAR Z43S (24 PPM)	1	1	1
⊙	029	*5MVM176DN034	2D922240	BUSH SHAFT CLUTCH	2	2	2
⊙	030	*302F331210	2F331210	SHAFT CLUTCH B	1	1	1
⊙	031	*5MBWN92F02NN	C2890150	POLY WASHER / M9.2X 15X0.2T	1	1	1
⊙	032	*5AAVGEAR+045	2D969870	GEAR Z22S ASSY	2	2	2
⊙	033	*5MVM331DN002	2D915200	BUSH DRIVE FUSER	1	1	1
⊙	034	*302D915211	2D915211	GEAR DRIVE FUSER Z22	1	1	1
⊙	035	*302F331220	2F331220	SHAFT CLUTCH	1	1	1
⊙	036	*302D922111	2D922111	GEAR Z48S	1	1	1
⊙	037	*5AAVGEAR+044	2D969180	GEAR Z29S ASSY	1	1	1
⊙	038	*302D922141	2D922141	GEAR Z14-Z20	1	1	1
⊙	039	*302D922101	2D922101	GEAR Z93S-Z24S	1	1	1
⊙	040	*5MMX763SD003	2D922090	PLATE DRIVE FUSER	1	1	1

SP	Ref. No.	Part.No.	Alternative.	Description	Quantity		
					110	120	230
⊙		302F393110	2F393110	DR-510B DRIVE FEED UNIT (16 PPM)	1	1	1
⊙		302F493040	2F493040	DR-520B DRIVE FEED UNIT (24 PPM)	1	1	1
⊙	041	*302F331260	2F331260	GEAR Z56H-Z20S	1	1	1
⊙	042	*302F344050	2F344050	STEPPING MOTOR FEED (16 PPM)	1	1	1
⊙	042	*302F431020	2F431020	STEPPING MOTOR FEED (24 PPM)	1	1	1
⊙	043	*5MVB732XB002	2D922020	COVER DRIVE FEED	1	1	1
⊙	044	*302D922081	2D922081	GEAR CL Z21S	2	2	2
⊙	045	*302F331130	2F331130	CLUTCH FEED	1	1	1
⊙	046	*302F331120	2F331120	CLUTCH REGIST	1	1	1
⊙	047	*302D922051	2D922051	GEAR Z30S	1	1	1
⊙	048	*302D922041	2D922041	GEAR Z35S	2	2	2
⊙	049	*302D922061	2D922061	GEAR Z38S-Z14S	1	1	1
⊙	050	*302D922071	2D922071	GEAR Z38S	1	1	1
⊙	051	*302F331140	2F331140	BRACKET DRIVE FEED	1	1	1
⊙	052	*5MMS656AX001	2D922260	SHEET MOTOR FEED (24 PPM)	1	1	1
	101	B1A53050	B1A53050	BIND T.T SCREW(+)/ M3 X 5 CRFREE S-T			
	102	5MBTPB3020TW++R	B1A53200	BIND T.T SCREW(+)/ M3 X 20 CRFREE S-T			
	103	5MBTPB4010PW++R	B1A64100	BIND T.T SCREW(+)/ M4 X 10 CRFREE P-T			
	104	5MBTPB3008PW++R	B1A63080	BIND T.T SCREW(+)/ M3 X 8 CRFREE P-T			

- Parts with "*" are component parts or sub-assemblies of the assembly appearing immediately above them.
- Parts with "⊙" indicates the spare parts.

- Parts with "•" are component parts or sub-assembly with "•" appearing immediately above them.

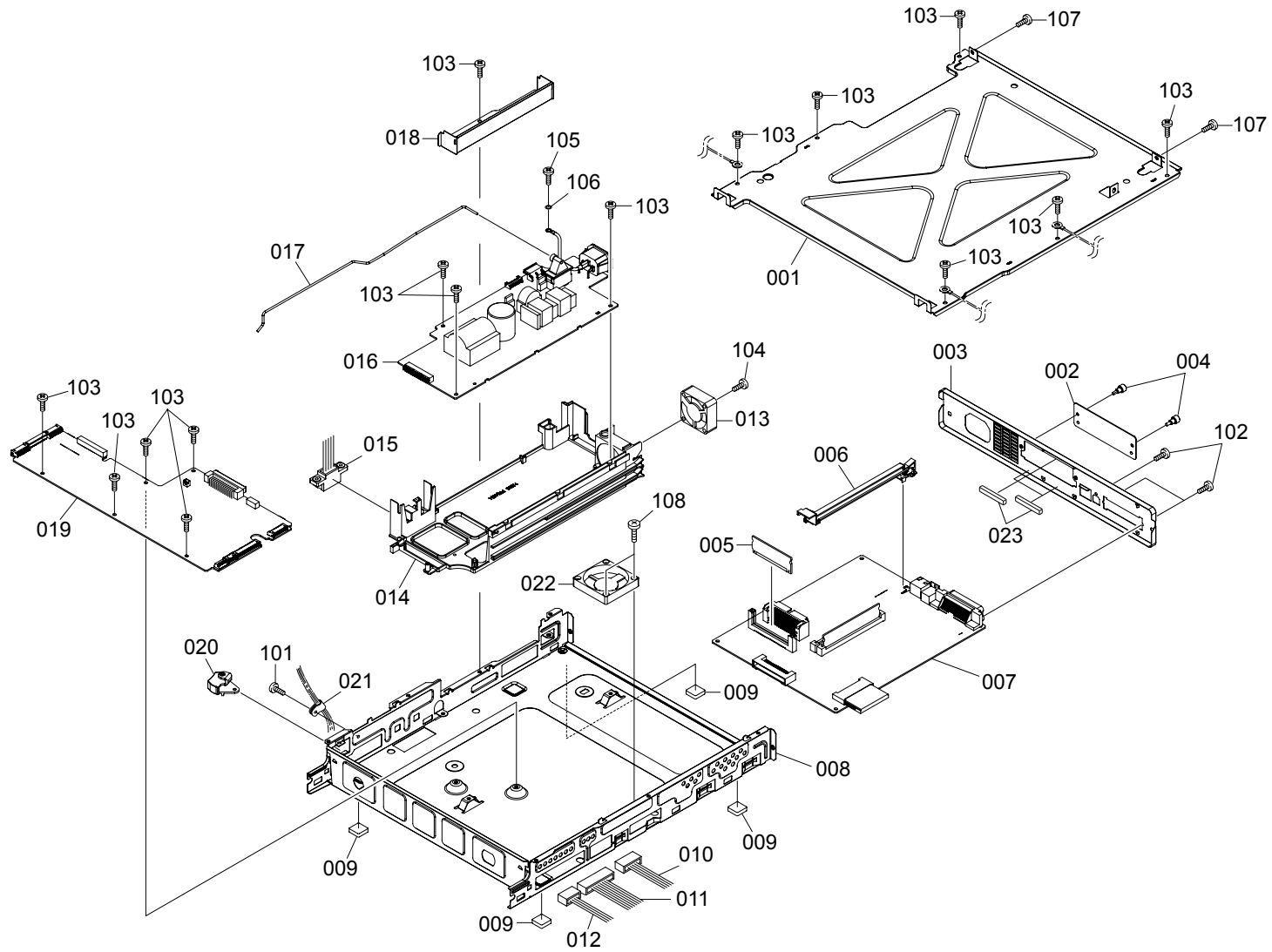

FIG. 4 Controller Box

2F3/2F4-6.0

SP	Ref. No.	Part.No.	Alternative.	Description	Quantity		
					110	120	230
	001	5MMS884SD001	2D903020	LID CONTROLLER	1	1	1
	002	303BH26021	3BH26021	PLATE OPTION	1	1	1
	003	5MMB861SD003	2D903030	PANEL REAR	1	1	1
⊙	004	5MMT263SN012++R	2D903100	SCREW OP	2	2	2
⊙	005	302F301241	2F301241	P.W.B.ASSY KP-1138 FLASH DIMM	1	1	1
	006	302D903071	2D903071	RAIL OPTION	1	1	1
⊙	007	302F380271	2F380271	P.W.B.MAIN KIT (16 PPM)	1	1	1
⊙	007	302F480040	2F480040	P.W.B.MAIN KIT (24 PPM)	1	1	1
	008	302D903011	2D903011	BOX CONTROLLER (16 PPM)	1	1	1
	008	302F403000	2F403000	BOX CONTROLLER (24 PPM)	1	1	1
⊙	009	5MVX221RB014	2BS03110	FOOT	4	4	4
	010	302F346060	2F346060	CONN. CORD ASSY S02880	1	1	1
	011	302F346110	2F346110	CONN.CORD ASSY S03108	1	1	1
	012	5AACCNSM6GEA++P	2D926070	CONN. CORD ASSY S02850	1	1	1
⊙	013	WNAA1060	5FZNF0506001+03	FAN MOTOR	1	1	1
	014	5MVX876SB009	2D903050	CASE PWB POWER	1	1	1
⊙	015	5AACCNSM8GEA++P	2D926090	CONN. CORD ASSY S02852	1	1	1
⊙	016	302F345030	2F345030	SWITCHING REGULATOR 230V (16 PPM) (Excl. KMA)			1
⊙	016	302F445010	2F445010	SWITCHING REGULATOR 230V (24 PPM) (Excl. KMA)			1
⊙	016	5AAEZA80U++2++P	2D928740	SWITCHING REGULATOR (16 PPM) (KMA)(KMTW)	1	1	
⊙	016	302F445020	2F445020	SWITCHING REGULATOR (24 PPM) (KMA)			1
⊙	016	302GV45010	2GV45010	SWITCHING REGULATOR /J (24 PPM) (KMTW)	1		
	017	5MMW803SD001	2D903060	ROD SW POWER	1	1	1
	018	5MMX733SD001	2D903040	BRACKET BOX	1	1	1
⊙	019	302F301350	2F301350	P.W.B.ASSY ENGINE WITH SOFTWARE(SP) (16 PPM)	1	1	1
⊙	019	302F401330	2F401330	P.W.B.ASSY ENGINE WITH SOFTWARE(SP) (24 PPM)	1	1	1
	020	5MVX433SH002	2BS03120	LEVER SW	1	1	1
	021	5MVX321NP001++R	2D902760	SHIELD CLAMP	1	1	1
	022	302F444010	2F444010	FAN MOTOR (24PPM)	1	1	1
	023	5MVQ411RX001++R	2D903140	EMI GASKET	3	3	3

SP	Ref. No.	Part.No.	Alternative.	Description	Quantity		
					110	120	230
	101	B4A03120		TP-A SCREW M3X12(TRIVALENT CHROMATING			
	102	5MBSPP3006NW++R	B0B03060	PAN HEAD SCREW(+)/ M3 X 6 CRFREE			
	103	5MBTPB3006TW++R	B1A53060	BIND T.T SCREW(+)/ M3 X 6 CRFREE S-T			
	104	5MBTPB3023WW++R	B1B73230	BIND T.T SCREW(+)/ M3 X 23 CRFREE P-T			
	105	5MBTPB4006TW++R	B1A54060	BIND T.T SCREW(+)/ M4 X 6 CRFREE S-T			
	106	5MBWG40854LD	CP003020	OT.LOCK WASHER / M4X8.5X0.4T SUS-DP			
	107	5MBTPB4010PW++R	B1A64100	BIND T.T SCREW(+)/ M4 X 10 CRFREE P-T			
	108	5MBTPB3012PW++R	B1A63120	BIND T.T SCREW(+)/ M3 X 12 CRFREE P-T			

- Parts with "*" are component parts or sub-assemblies of the assembly appearing immediately above them.
- Parts with "⊙" indicates the spare parts.

- Parts with "••" are component parts or sub-assembly with "•" appearing immediately above them.

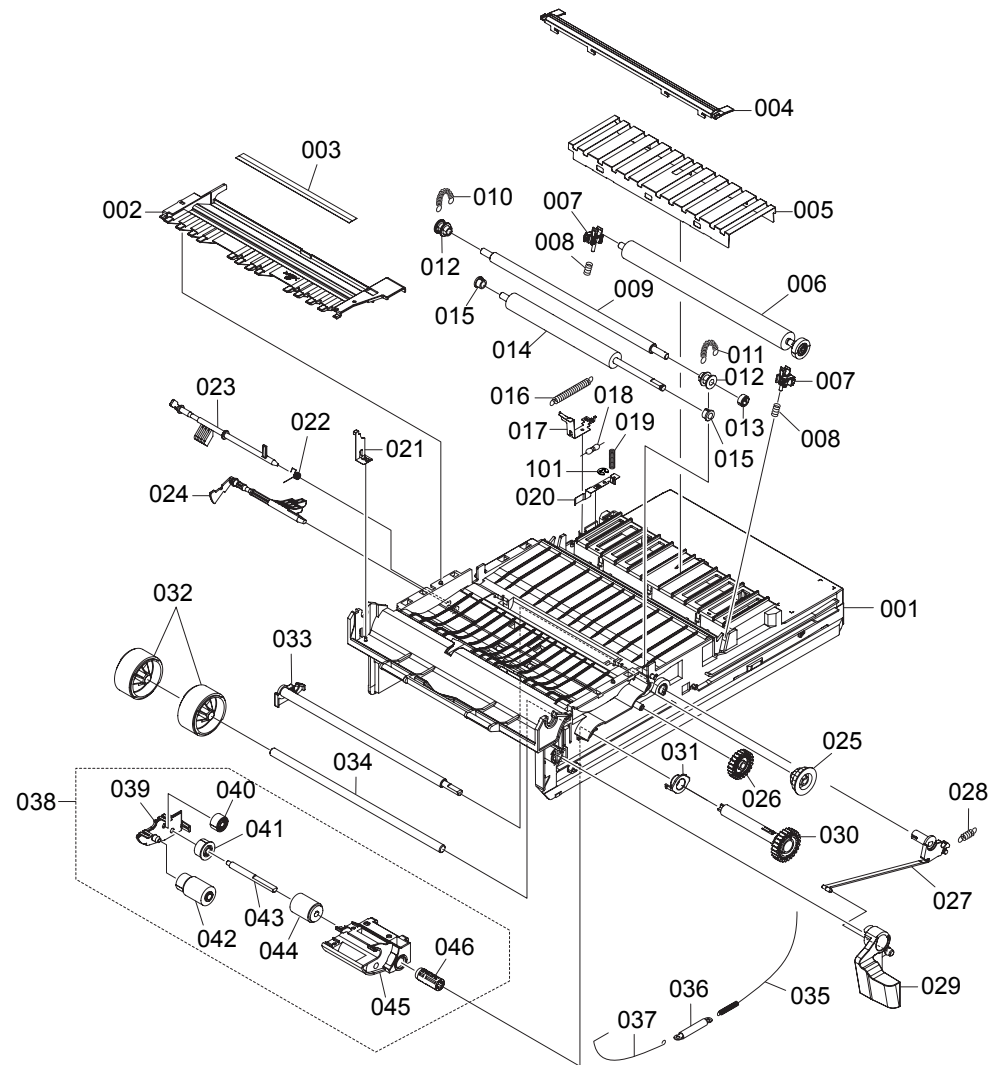

FIG. 5 Paper Feed Unit

2F3/2F4-6.0

SP	Ref. No.	Part.No.	Alternative.	Description	Quantity		
					110	120	230
⊙	001	302F300290	2F300290	FEED TRANS UNIT	1	1	1
		*302D916051	2D916051	BASE FEED	1	1	1
	002	*302D916071	2D916071	GUIDE PAPER	1	1	1
⊙	003	*5MVS721KF005	2D916150	SHEET REGIST	1	1	1
⊙	004	*302D916081	2D916081	PAPER CHUTE	1	1	1
	005	*302F300670	2F300670	DISCHARGER ASSY	1	1	1
⊙	006	*302F300850	2F300850	ROLLER TRANSFER ASSY	1	1	1
⊙	007	*5MVX322DB019	2BS16380	BUSH TRANSFER	2	2	2
	008	*5MMW251SX004	2D916060	SPRING TRANS	2	2	2
⊙	009	*302F324000	2F324000	ROLLER REGIST UP	1	1	1
	010	*5MMW341LD011	2D916250	SPRING REGIST L	1	1	1
	011	*5MMW341LD008	2BR16240	SPRING REGIST R	1	1	1
⊙	012	*5MVM221DB002	2BS16290	BUSH REGIST	2	2	2
⊙	013	*5MVG126DN015	2BS16240	GEAR REGIST Z19S	1	1	1
⊙	014	*302F324020	2F324020	ROLLER REGIST LOW	1	1	1
⊙	015	*5MVM176DN019	2B716270	BUSH POM A	2	2	2
	016	*5MMW641SD001	2D916130	SPRING EARTH B	1	1	1
	017	*5MMX543LD006	2D916110	PLATE EARTH TC	1	1	1
	018	*5FRHA3A10702+01	RH0A0040	M.GLAZE R. 100M 1W	1	1	1
	019	*5MMW241SX005	2B716150	SPRING TRANS R	1	1	1
	020	*5MMX543LD007	2D916210	PLATE EARTH FEED	1	1	1
	021	*5MMX422LD012	2D916140	PLATE EARTH MP	1	1	1
	022	*5MMW161SD014	2D916260	SPRING ACTUATOR REG	1	1	1
⊙	023	*302F324040	2F324040	SENSOR DOC	1	1	1
⊙	024	*5MVX663SB013	2BS16410	ACTUATOR PAPER	1	1	1
⊙	025	*5MVG148DN060	2BS16270	GEAR REG Z2S-Z3S	1	1	1
⊙	026	*302D916221	2D916221	GEAR IDLE Z23S	1	1	1
	027	*5MVX733DN002	2D916090	HOOK RELEASE	1	1	1
	028	*5MMW251SD002	2BR16250	SPRING LOCK R	1	1	1
	029	*2BS16431	2BS16431	LEVER LOCK	1	1	1
⊙	030	*5MVG038DN002	2D916230	GEAR JOINT Z26S	1	1	1
⊙	031	*5MVM222XN001	2BS16300	BUSH FEED	1	1	1
⊙	032	*302FP06100	2FP06100	ROLLER GUIDE ASSY	2	2	2
	033	*5MVX843CB004	2BS16470	SHAFT RELEASE	1	1	1
	034	*302F324030	2F324030	SHAFT ROLL GUIDE	1	1	1
	035	*5MMW641SD002	2D916270	SPRING EARTH C	1	1	1
	036	*5AACCSU6GEA++P	2D926390	CONN. CORD ASSY S02988	1	1	1
	037	*5MMW641SD003	2D916280	WIRE EARTH M/P	1	1	1
⊙	038	*5AAYA37E++35	2BR68470	HOLDER FEED ASSY	1	1	1
	039	**5MVX642DH001	2BS16400	COVER BKT FEED	1	1	1
	040	**5MVG137DN036	2BS16250	GEAR FEED IDLE Z29S	1	1	1
⊙	041	**5AAVGEAR+037	2BR70440	GEAR PICKUP	1	1	1
⊙	042	**5AAVROLL+047	2CL16090	ROLLER FEED ASSY	1	1	1
	043	**5MMT664SN002	2BR16370	SHAFT PICKUP	1	1	1
⊙	044	**5AAVROLL+048	2CL16100	ROLLER PICKUP ASSY	1	1	1
	045	**5MVX664SH004	2BS16420	BRACKET FEED	1	1	1
⊙	046	**5MVX376DN001	2BS16390	HOLDER RELEASE	1	1	1

SP	Ref. No.	Part.No.	Alternative.	Description	Quantity		
					110	120	230
	101	5MBCS2425XSP	D4000240	CS STOP RING /X2.4 X .25T S-BLK			

- Parts with "*" are component parts or sub-assemblies of the assembly appearing immediately above them.
- Parts with "⊙" indicates the spare parts.

- Parts with ".*" are component parts or sub-assembly with ".*" appearing immediately above them.

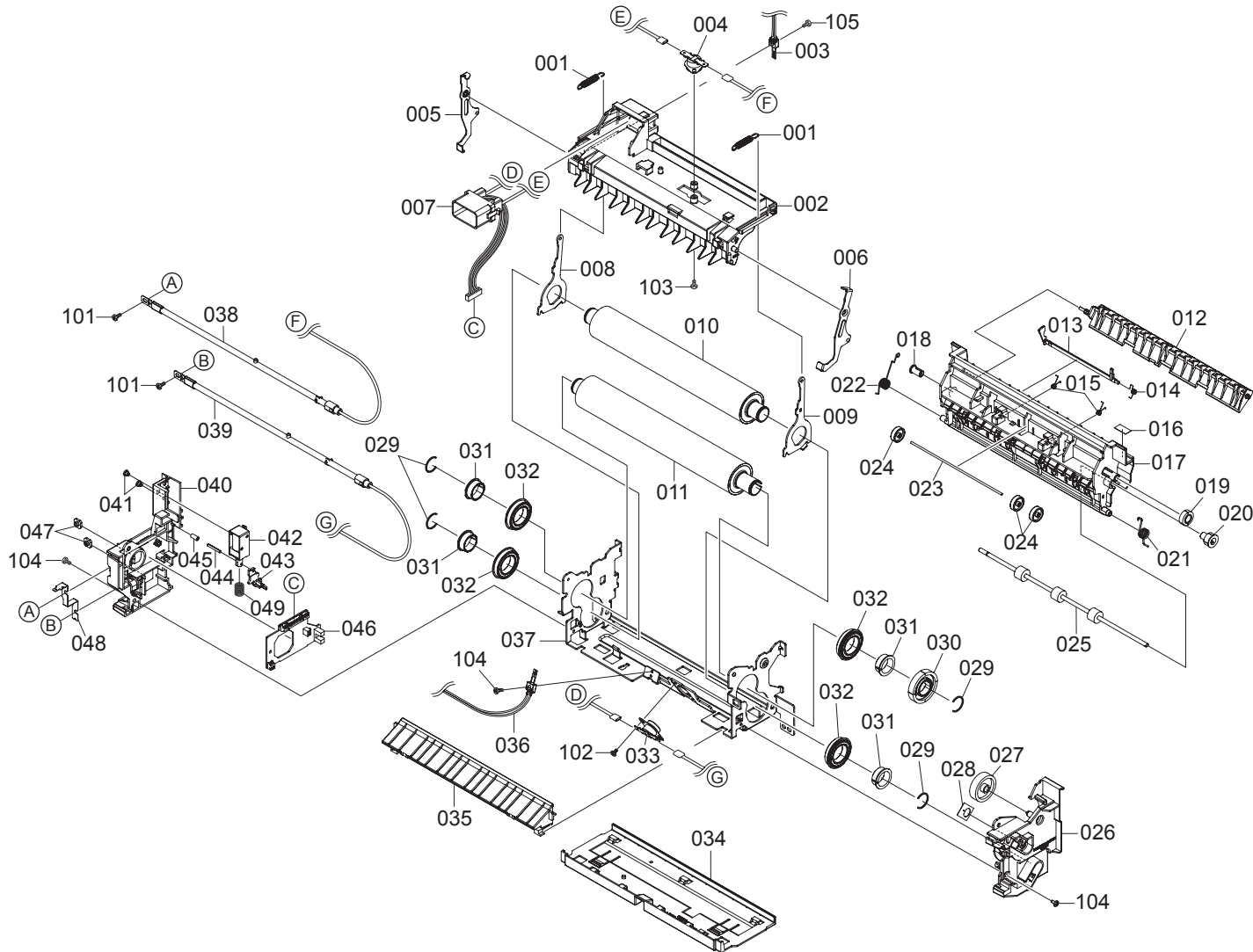

FIG. 6 Fuser Unit (16 PPM)

2F3/2F4-6.0

SP	Ref. No.	Part.No.	Alternative.	Description	Quantity		
					110	120	230
⊙		302F393070	2F393070	FK-510(E) FUSER UNIT (16 PPM)			1
⊙		302F393080	2F393080	FK-510(U) FUSER UNIT (16 PPM)	1	1	1
⊙	001	*5MMW361SD005	2D920250	SPRING PRESS	2	2	2
⊙	002	*5MV B866KB002	2D920320	FRAME FUSER UP	1	1	1
⊙	003	*2D927090	5AAXTM016GEA++P	THERMISTOR ASSY	1	1	1
⊙	004	*YFOA1530	5FYFFQ15001++03	THERMOSTAT 250V150C	1	1	1
⊙	005	*5MMX641SD005	2D920190	PLATE RELEASE L	1	1	1
⊙	006	*5MMX641SD006	2D920200	PLATE RELEASE R	1	1	1
⊙	007	*5AACNSN3GEA++P	2D926130	CONN. CORD ASSY S02857			
⊙	007	*5AACNSN4GEA++P	2D926140	CONN. CORD ASSY S02858	1	1	1
⊙	008	*5MMX641SD003	2D920170	PLATE PRESS L	1	1	1
⊙	009	*5MMX641SD004	2D920180	PLATE PRESS R	1	1	1
⊙	010	*5MMT888AX024	2D920060	ROLLER FIX UP	1	1	1
⊙	011	*5MMT888AX025	2D920070	ROLLER FIX LOW	1	1	1
⊙	012	*5MVX833CB006	2D920140	GUIDE CHANGE	1	1	1
⊙	013	*5MVX731CB004	2D920150	ACTUATOR FUSER	1	1	1
⊙	014	*5MMW151LD007	2D920280	SPRING ACTUATOR	1	1	1
⊙	015	*5MMW501LD003	2D920300	SPRING PULLEY EXIT	2	2	2
⊙	016	*302F325030	2F325030	LABEL EXIT	1	1	1
⊙	017	*5MVX865KB003	2D920080	GUIDE EXIT	1	1	1
⊙	018	*5MVM266DN006	2BS02290	BUSH FD	1	1	1
⊙	019	*302F325060	2F325060	GEAR IDLE Z18	1	1	1
⊙	020	*302D920041	2D920041	GEAR EXIT Z15S	1	1	1
⊙	021	*5MMW161SD013	2D920270	SPRING EXIT R	1	1	1
⊙	022	*5MMW161SD012	2D920260	SPRING EXIT L	1	1	1
⊙	023	*5MMT722SZ001	2BR20370	SHAFT EXIT	1	1	1
⊙	024	*302F325070	2F325070	PULLEY EXIT	3	3	3
⊙	025	*302F325000	2F325000	ROLLER EXIT	1	1	1
⊙	026	*5MVB663KB003	2D920120	COVER FUSER R	1	1	1
⊙	027	*302F325040	2F325040	GEAR JOINT Z36	1	1	1
⊙	028	*302F325020	2F325020	SEAL HEATER R	1	1	1
⊙	029	*302D925020	2D925020	RING STOP	4	4	4
⊙	030	*5MVG154XN001	2D920020	GEAR HEAT Z43S	1	1	1
⊙	031	*5MVM180XN002	2D920030	BUSH FUSER	4	4	4
⊙	032	*5MBE6804ZZNR	2D920350	FUSER BEARING	4	4	4
⊙	033	*YFOA1530	5FYFFQ15001++03	THERMOSTAT 250V150C	1	1	1
⊙	034	*5MVX872KB001	2D920130	COVER FUSER LOW	1	1	1
⊙	035	*5MVB833KB004	2D920330	GUIDE ENTRANCE LOW	1	1	1
⊙	036	*2D927090	5AAXTM016GEA++P	THERMISTOR ASSY	1	1	1
⊙	037	*5MMX876SD003	2D920050	FRAME FUSER	1	1	1
⊙	038	*5HZPB2412120801	2D920400	LAMP HEATER UP 240V			
⊙	038	*5HZPB1214220901	2D920440	LAMP HEATER UP 120V	1	1	
⊙	039	*5HZPB2411520201	2D920450	LAMP HEATER LOW 240V			1
⊙	039	*5FZPB1212920101	WP0A0540	LAMP HEATER LOW 120V	1	1	
⊙	040	*302D925010	2D925010	COVER FUSER L	1	1	1
⊙	041	*302F325010	2F325010	STUD SCREW M3	2	2	2
⊙	042	*5FZSA2401020309	WSAA0170	SOLENOID	1	1	1
⊙	043	*302D920012	2D920012	ACTUATOR SOL	1	1	1
⊙	044	*5MBP2518WXSP	E0025180	SPRING PIN /M2.5 X 18 S-BLK	1	1	1
⊙	045	*5MVM111RB002	2BR20450	RUBBER PIN	1	1	1

SP	Ref. No.	Part.No.	Alternative.	Description	Quantity		
					110	120	230
⊙	046	*5AAPRIFC1030AHP	2D901460	P.W.B.ASSY KP-970 FUSER	1	1	1
	047	*5MMS111SL002	2BY20050	NUT FUSER A	2	2	2
	048	*5MMX641RD001	2D920220	PLATE HEATER L	1	1	1
	049	*5MMW261LJ032	2BM21060	SPRING SOL	1	1	1
	101	5MBSP43006NW++R	B4A03060	TP HEAD SCREW(+)/ M3 X 6 DRFREE			
	102	5MBTPB3006TW++R	B1A53060	BIND T.T SCREW(+)/ M3 X 6 CRFREE S-T			
	103	5MBTPB3008PW++R	B1A63080	BIND T.T SCREW(+)/ M3 X 8 CRFREE P-T			
	104	5MBTPB3008TW++R	B1A53080	BIND T.T SCREW(+)/ M3 X 8 CRFREE S-T			
	105	5MBTPB3012PW++R	B1A63120	BIND T.T SCREW(+)/ M3 X 12 CRFREE P-T			

- Parts with "*" are component parts or sub-assemblies of the assembly appearing immediately above them.
- Parts with "⊙" indicates the spare parts.

- Parts with "•" are component parts or sub-assembly with "•" appearing immediately above them.

FIG. 6 Fuser Unit (24 PPM)

2F3/2F4-6.0

SP	Ref. No.	Part.No.	Alternative.	Description	Quantity		
					110	120	230
⊙		302F493010	2F493010	FK-520(E) FUSER UNIT (24 PPM)			1
⊙		302F493020	2F493020	FK-520(U) FUSER UNIT (24 PPM)	1	1	1
⊙	001	*2D927090	5AAXTM016GEA++P	THERMISTOR ASSY	1	1	1
⊙	002	*5MMW171LD007	2D920310	RING STOP	1	1	1
⊙	003	*302F325040	2F325040	GEAR JOINT Z36	1	1	1
⊙	004	*5MMS111SL002	2BY20050	NUT FUSER A	1	1	1
	005	*302F425120	2F425120	COVER FUSER UP	1	1	1
	006	*302F446010	2F446010	CONN.CORD ASSY HEATER-DRAWER	1	1	1
⊙	007	*302F425440	2F425440	GEAR HEAT Z43S	1	1	1
	008	*302D920012	2D920012	ACTUATOR SOL	1	1	1
	009	*302F325010	2F325010	STUD SCREW M3	2	2	2
	010	*302F425141	2F425141	COVER FUSER L	1	1	1
⊙	011	*302F425450	2F425450	BUSH FUSER	2	2	2
	012	*5MBP2518WXSP	E0025180	SPRING PIN	1	1	1
	013	*5MVM111RB002	2BR20450	RUBBER PIN	1	1	1
⊙	014	*5FZSA2401020309	WSAA0170	SOLENOID /TDS-KN07A-21F	1	1	1
	015	*5MMW261LJ032	2BM21060	SPRING SOL	1	1	1
⊙	016	*YFOA1530	5FYFFQ15001++03	THERMOSTAT 250V150 C/CS-7SA 6A	1	1	1
	017	*302F425100	2F425100	PLATE PITCH	2	2	2
	018	*302F425193	2F425193	HOLDER BELT L	1	1	1
	019	*302F425203	2F425203	HOLDER BELT R	1	1	1
⊙	020	*302F425270	2F425270	BELT FUSER	1	1	1
⊙	021	*302F425290	2F425290	ROLLER BELT	1	1	1
⊙	022	*7BE686ZZ++++H01	BE010080	FUSER BELT BEARING	4	4	4
⊙	023	*5MBE6804ZZNR	2D920350	FUSER BEARING /6804ZZNR M/20D	2	2	2
⊙	024	*302F425361	2F425361	GEAR EXIT Z18S	1	1	1
⊙	025	*302F425330	2F425330	ROLLER EXIT	1	1	1
	026	*302F325030	2F325030	LABEL EXIT	1	1	1
⊙	027	*5MVM266DN006	2BS02290	BUSH FD	1	1	1
⊙	028	*302F425350	2F425350	GEAR IDLE Z15S-Z18S	1	1	1
⊙	029	*302F325070	2F325070	PULLEY EXIT	5	5	5
	030	*302F425161	2F425161	GUIDE EXIT	1	1	1
⊙	031	*302F425212	2F425212	ACTUATOR FUSER	1	1	1
	032	*302F425230	2F425230	SPRING EXIT L	1	1	1
	033	*302F425240	2F425240	SPRING EXIT R	1	1	1
	034	*302F425250	2F425250	SPRING PULLEY EXIT	2	2	2
	035	*302F425260	2F425260	SPRING ACTUATOR	1	1	1
	036	*302F425370	2F425370	SHAFT EXIT	1	1	1
	037	*302F425341	2F425341	GUIDE CHANGE	1	1	1
	038	*302F425012	2F425012	PLATE FUSER L	1	1	1
	039	*302F425021	2F425021	PLATE FUSER R	1	1	1
	040	*302F425030	2F425030	STAY FUSER A	1	1	1
	041	*302F425040	2F425040	STAY FUSER B	1	1	1
	042	*302F425050	2F425050	STAY FUSER C	1	1	1
	043	*302F425060	2F425060	PLATE PRESS L	1	1	1
	044	*302F425070	2F425070	PLATE PRESS R	1	1	1
	045	*302F425080	2F425080	PLATE RELEASE L	1	1	1
	046	*302F425090	2F425090	PLATE RELEASE R	1	1	1
	047	*302F425110	2F425110	PLATE SEPARATOR	1	1	1
	048	*302F425130	2F425130	PULLEY PRESS	2	2	2

SP	Ref. No.	Part.No.	Alternative.	Description	Quantity		
					110	120	230
	049	*302F425151	2F425151	COVER FUSER R	1	1	1
	050	*302F425171	2F425171	GUIDE EXIT UP	1	1	1
	051	*302F425180	2F425180	GUIDE ENTRANCE	1	1	1
⊙	052	*302F425220	2F425220	SPRING PRESS	2	2	2
⊙	053	*302F425281	2F425281	ROLLER HEAT	1	1	1
⊙	054	*302F425311	2F425311	LAMP HEATER 120V	1	1	1
⊙	054	*302F425301	2F425301	LAMP HEATER 240V			1
⊙	055	*302F401280	2F401280	P.W.B. ASSY FUSER	1	1	1
⊙	056	*302F425430	2F425430	ROLLER BELT A	1	1	1
	057	*302F425470	2F425470	SPRING CHANGE	1	1	1
	058	*302F425390	2F425390	SLEEVE FUSER GEAR	1	1	1
	059	*302F425400	2F425400	SEAL LUMP HOLD R	1	1	1
	060	*302F425410	2F425410	SEAL LUMP HOLD L	1	1	1
	061	*302F425420	2F425420	SEAL COVER FUSER	1	1	1
	062	*302F425460	2F425460	SPRING SLEEVE	3	3	3
⊙	063	*302F425480	2F425480	RING STOP	1	1	1
	101	5MBSP43006NW++R	B4A03060	TP HEAD SCREW(+)/ M3 X 6 DRFREE			
	102	5MBTPB3008TW++R	B1A53080	BIND T.T SCREW(+)/ M3 X 8 CRFREE S-T			
	103	5MBTPB3006TW++R	B1A53060	BIND T.T SCREW(+)/ M3 X 6 CRFREE S-T			

- Parts with "*" are component parts or sub-assemblies of the assembly appearing immediately above them.
- Parts with "⊙" indicates the spare parts.

- Parts with "••" are component parts or sub-assembly with "•" appearing immediately above them.

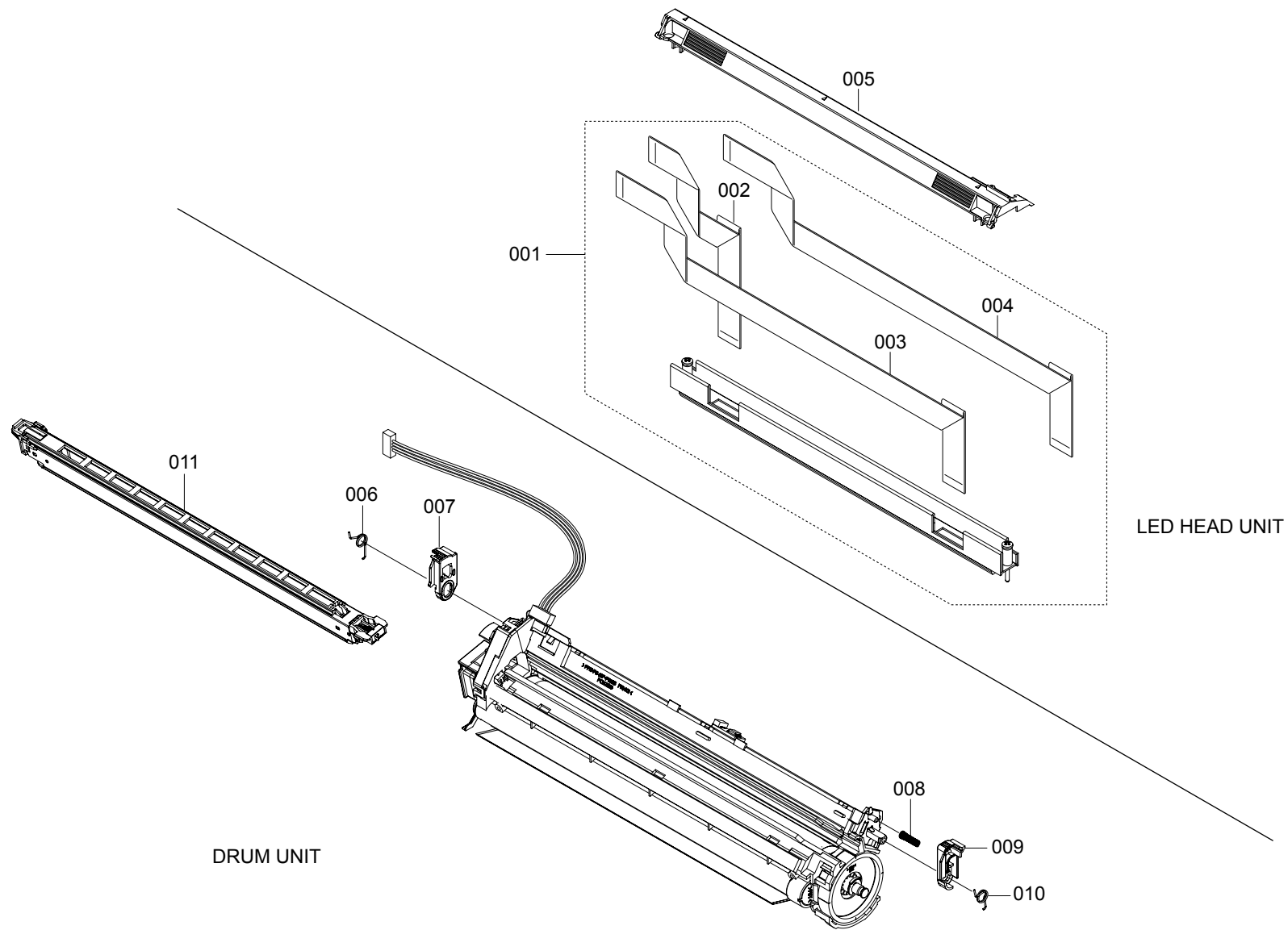

FIG. 7 Drum Unit / LED Unit

2F3/2F4-6.0

SP	Ref. No.	Part.No.	Alternative.	Description	Quantity		
					110	120	230
⊙	001	302F393090	2F393090	LK-510 LED HEAD UNIT (16 PPM)	4	4	4
⊙	001	302F493081	2F493081	LK-520 LED HEAD UNIT (24 PPM)	4	4	4
⊙	001	302GV93090	2GV93090	LK-520 (24 PPM)	4		
⊙	002	*302F346010	2F346010	CONN. CORD ASSY LEDRLY-BLH		4	4
⊙	002	*302F346010	2F346010	CONN. CORD ASSY LEDRLY-BLH (16 PPM)	4		
⊙	002	*302GV46010	2GV46010	CONN.CORD ASSY S03145 (24 PPM)	4		
⊙	003	*302F346020	2F346020	CONN. CORD ASSY LEDRLY-BLH		4	4
⊙	003	*302F346020	2F346020	CONN. CORD ASSY LEDRLY-BLH (16 PPM)	4		
⊙	003	*302F446120	2F446120	CONN.CORD ASSY S03144 (24 PPM)	4		
⊙	004	*302F446051	2F446051	SHIELD FFC ASSY (24 PPM)	4	4	4
⊙	005	302F311021	2F311021	COVER LED	4	4	4
⊙		302F393010	2F393010	DK-510 DRUM UNIT (16 PPM)	4	4	4
⊙		302F493061	2F493061	DK-520 DRUM UNIT (24 PPM)	4	4	4
	006	*5MMW161LD056	2D908360	SPRING LOCK L	4	4	4
	007	*5MVX421SL001	2D908340	LEVER DRUM L	4	4	4
	008	*5MMW241LD024	2D908000	SPRING EARTH	4	4	4
	009	*5MVX422SL003	2D908350	LEVER DRUM R	4	4	4
	010	*5MMW161LD057	2D908370	SPRING LOCK R	4	4	4
⊙	011	*302F393190	2F393190	MC-510 MCH ASSY	4	4	4

- Parts with "*" are component parts or sub-assemblies of the assembly appearing immediately above them.
- Parts with "⊙" indicates the spare parts.

- Parts with "••" are component parts or sub-assembly with "•" appearing immediately above them.

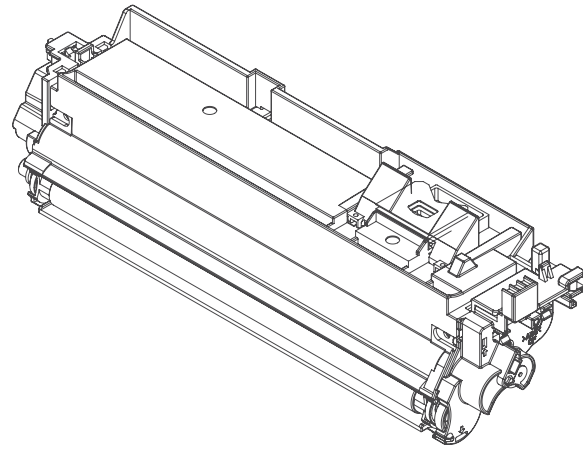

FIG. 8 Developer Unit

2F3/2F4-6.0

SP	Ref. No.	Part.No.	Alternative.	Description	Quantity		
					110	120	230
⊙		302F393021	2F393021	DV-510K DLP UNIT K	1		1
⊙		302F393161	2F393161	DV-512K DLP UNIT K (Excl.KMTW)		1	
⊙		302F393031	2F393031	DV-510Y DLP UNIT Y	1		1
⊙		302F393131	2F393131	DV-512Y DLP UNIT Y (Excl.KMTW)		1	
⊙		302F393051	2F393051	DV-510M DLP UNIT M	1		1
⊙		302F393141	2F393141	DV-512M DLP UNIT M (Excl.KMTW)		1	
⊙		302F393041	2F393041	DV-510C DLP UNIT C	1		1
⊙		302F393151	2F393151	DV-512C DLP UNIT C (Excl.KMTW)		1	

- Parts with "•" are component parts or sub-assemblies of the assembly appearing immediately above them.
- Parts with "⊙" indicates the spare parts.

- Parts with "••" are component parts or sub-assembly with "•" appearing immediately above them.

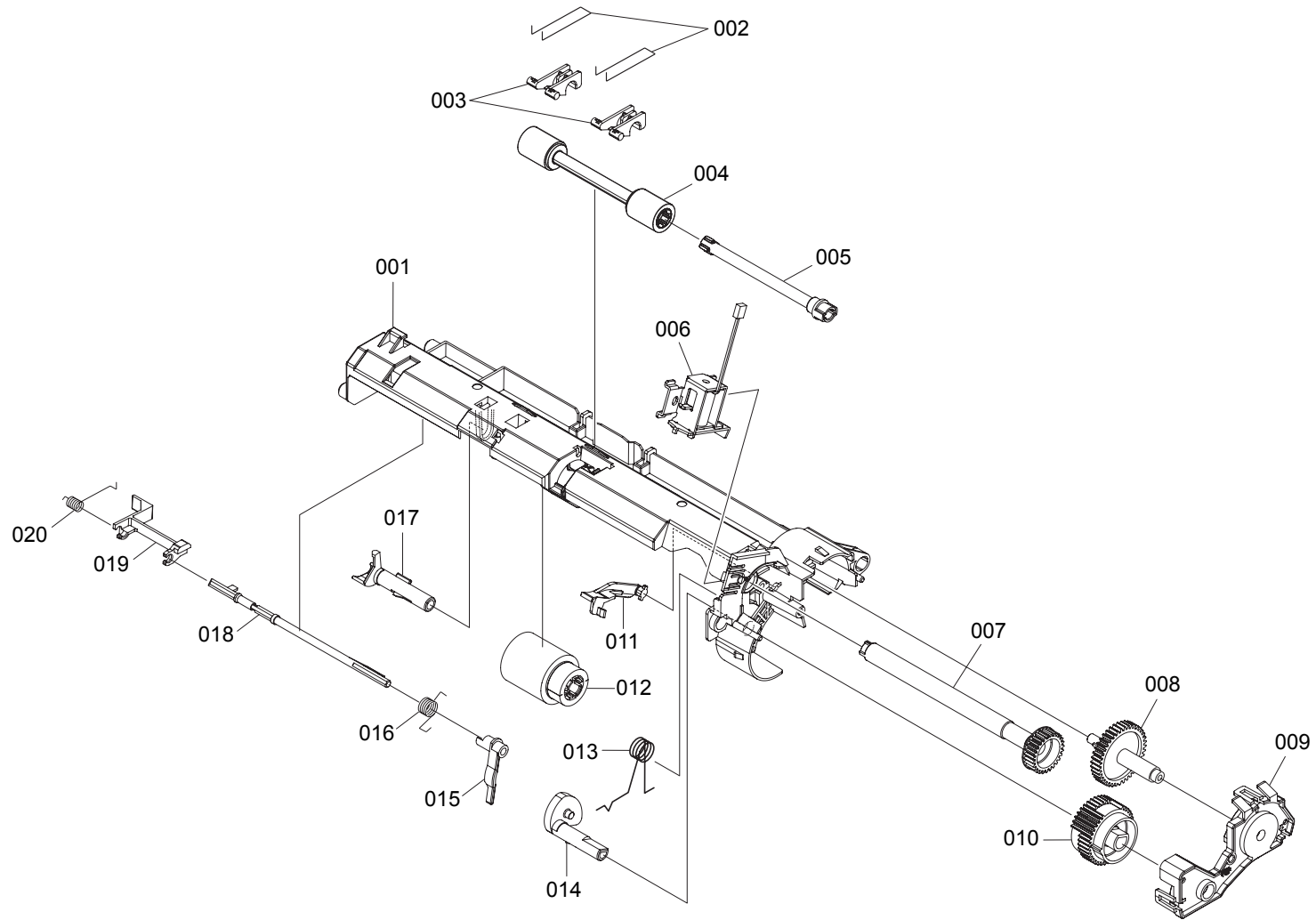

FIG. 9 Frame MP Assembly

2F3/2F4-6.0

SP	Ref. No.	Part.No.	Alternative.	Description	Quantity		
					110	120	230
⊙		2D968390	5AAYA80E++03	FRAME MP ASSY	1	1	1
	001	*5MVX866CH011	2FP02130	FRAME M/P	1	1	1
	002	*5MMW601SD001	2BR02440	SPRING MID M/P	2	2	2
⊙	003	*5MVX321DN014	2BS02340	BUSH MID M/P	2	2	2
⊙	004	*5AAVR0LL+050	2CL16120	ROLL MID M/P ASSY	1	1	1
	005	*5MVT676CB003	2BS02320	SHAFT MID B	1	1	1
⊙	006	*302D944010	2D944010	SOLENOID M/P ASSY	1	1	1
⊙	007	*5MVG133DN008	2BS02230	GEAR M/P Z27	1	1	1
	008	*5MVG158XN005	2D916010	GEAR MID Z42S	1	1	1
	009	*5MVX662DN003	2BS02440	HOLDER CLUTCH M/P	1	1	1
	010	*5MVG148DN063	2BS02280	GEAR M/P Z40	1	1	1
	011	*5MVX522DN004	2BS02400	LEVER CAM	1	1	1
⊙	012	*5AAVR0LL+051	2CL16130	ROLLER M/P ASSY	1	1	1
	013	*5MMW161LD043	2BR02450	SPRING CAM M/P	1	1	1
⊙	014	*5MVX433DN002	2BS02380	CAM M/P	1	1	1
⊙	015	*5MVX421SB021	2BS02360	ACTUATOR M/P C	1	1	1
	016	*5MMW161SD009	2BR02530	SP ACTUATOR M/P C	1	1	1
⊙	017	*5MVX422DN007	2BS02370	HOLDER FEED M/P	1	1	1
⊙	018	*5MVT754SB001	2BS02330	ACTUATOR M/P A	1	1	1
⊙	019	*5MVX621SB010	2BS02410	ACTUATOR M/P B	1	1	1
	020	*5MMW161SD010	2BR02520	SP ACTUATOR M/P B	1	1	1

- Parts with "*" are component parts or sub-assemblies of the assembly appearing immediately above them.
- Parts with "⊙" indicates the spare parts.

- Parts with "••" are component parts or sub-assembly with "•" appearing immediately above them.

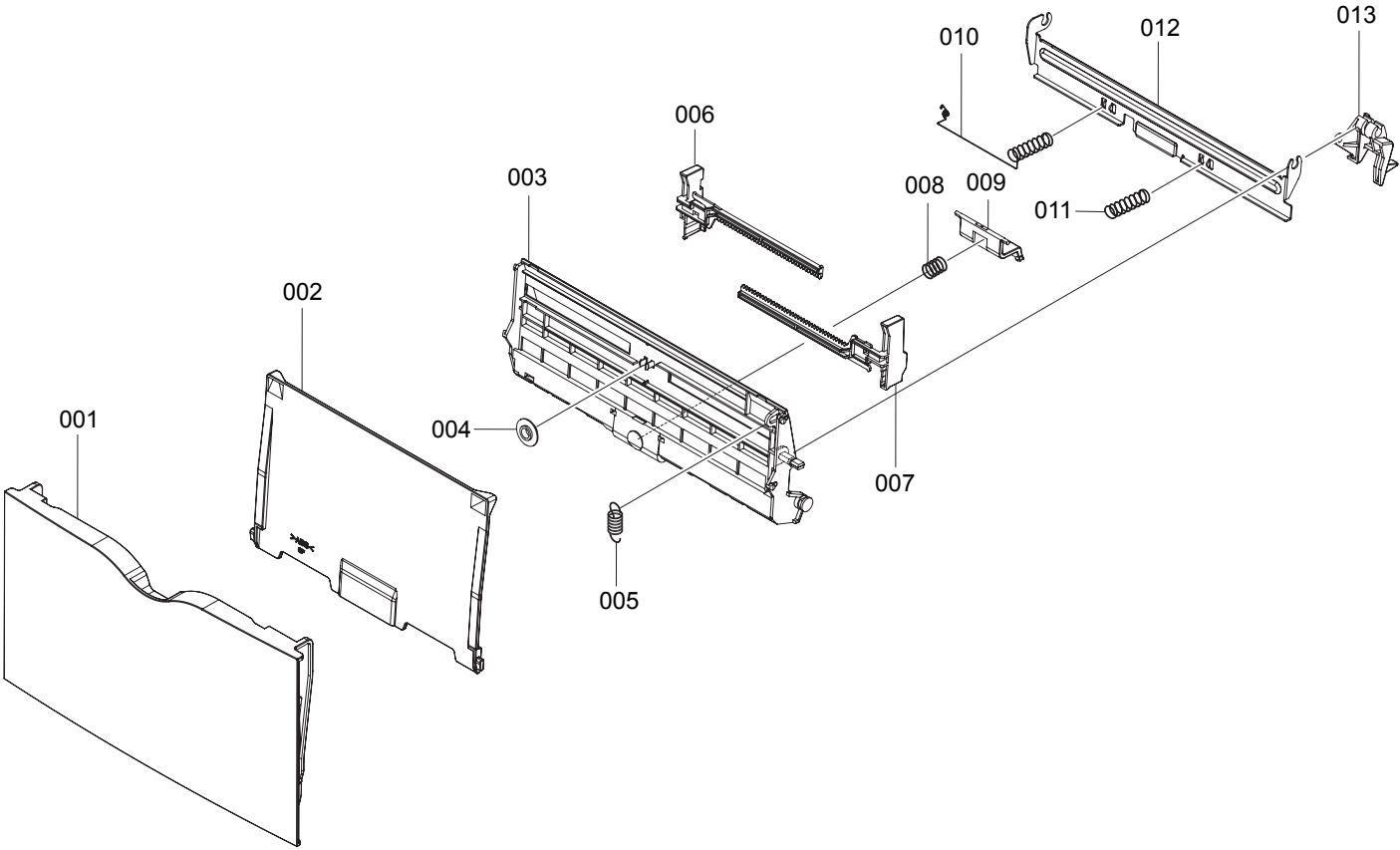

FIG. 10 MP Tray

2F3/2F4-6.0

SP	Ref. No.	Part.No.	Alternative.	Description	Quantity		
					110	120	230
⊙		302F300000	2F300000	TRAY M/P ASSY	1	1	1
⊙	001	*5MVB878SH001	2D906020	COVER M/P	1	1	1
	002	*302D906012	2D906012	TRAY M/P	1	1	1
	003	*5MVB864SH009	2BS06250	BASE M/P	1	1	1
	004	*5MVG127DH001	2B700380	GEAR MANUAL	1	1	1
	005	*5MMW261SM001	2BS06170	SPRING LOCK M/P	1	1	1
	006	*5MVL673DH003	2D906030	GUIDE M/P L	1	1	1
	007	*5MVL673DH004	2D906040	GUIDE M/P R	1	1	1
	008	*5MMW261LD039	2BS06160	SPRING SEPARATOR	1	1	1
⊙	009	*5AAVCASET248	2BR00140	SEPARATOR M/P ASSY	1	1	1
	010	*5MMW461SD006	2D916020	SP BOTTOM M/P L	1	1	1
	011	*5MMW461SD004	2BS06190	SP BOTTOM M/P R	1	1	1
⊙	012	*5AAVCASET249	2BR00150	BOTTOM MULTI ASSY	1	1	1
	013	*5MVX533DN002	2BS06460	BRACKET BOTTOM	1	1	1

- Parts with "*" are component parts or sub-assemblies of the assembly appearing immediately above them.
- Parts with "⊙" indicates the spare parts.

- Parts with "••" are component parts or sub-assembly with "•" appearing immediately above them.

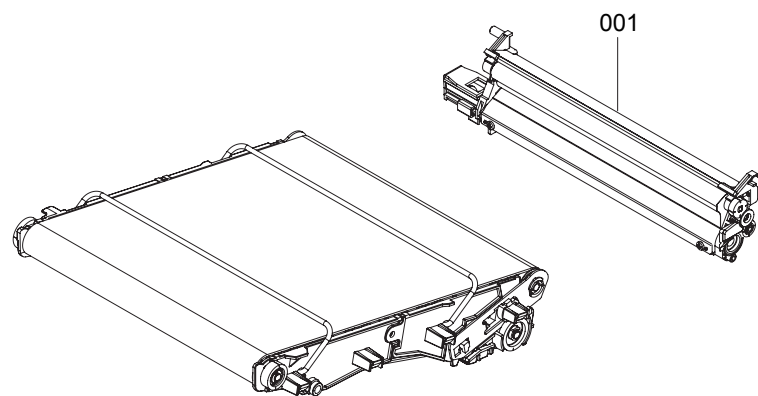

FIG. 11 Primary Transfer Unit

2F3/2F4-6.0

SP	Ref. No.	Part.No.	Alternative.	Description	Quantity		
					110	120	230
⊙		302F393170	2F393170	TR-510 PRE TRANSFER UNIT (16 PPM)	1	1	1
⊙		302F493090	2F493090	TR-520 PRE TRANSFER UNIT (24 PPM)	1	1	1
⊙	001	*302F393200	2F393200	CL-510 CLEANING UNIT	1	1	1

- Parts with "*" are component parts or sub-assemblies of the assembly appearing immediately above them.
- Parts with "⊙" indicates the spare parts.

- Parts with "••" are component parts or sub-assembly with "•" appearing immediately above them.

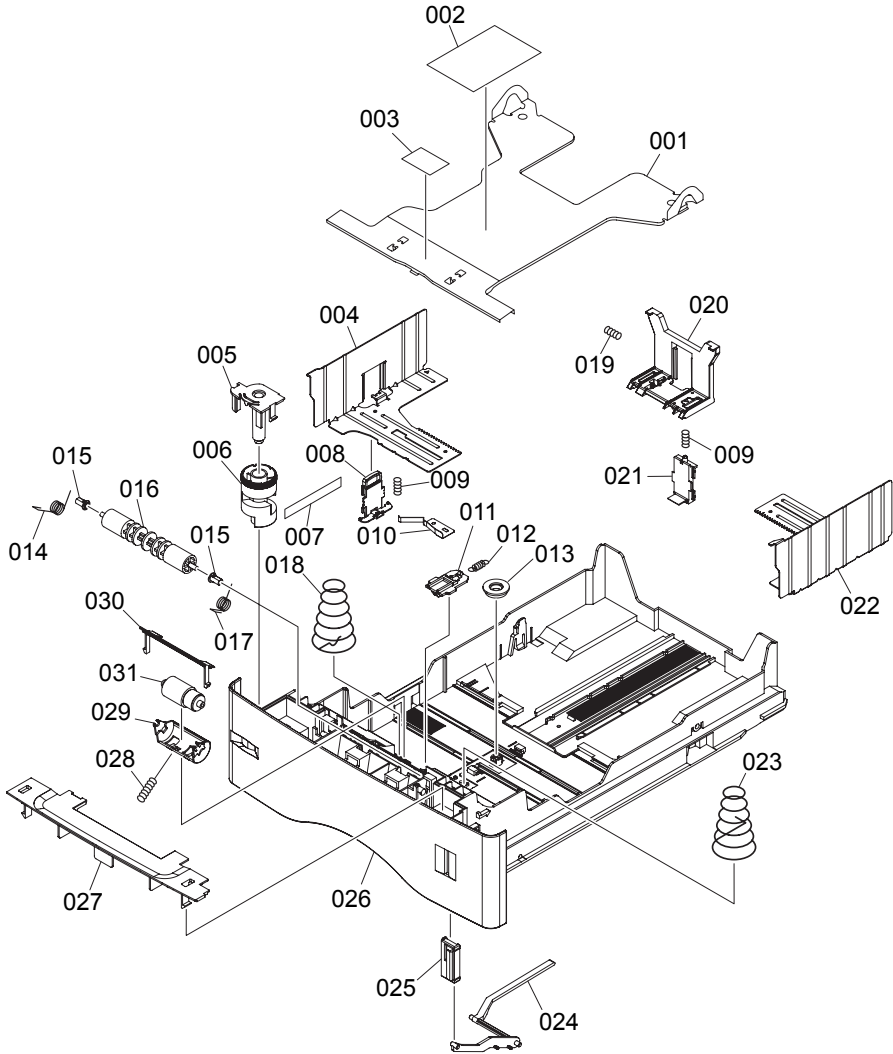

FIG. 12 Paper Cassette

2F3/2F4-6.0

SP	Ref. No.	Part.No.	Alternative.	Description	Quantity		
					110	120	230
⊙		5PLPXZ7APKX	2BR93360	PC-60LG(A4) CASSETTE ASSY			1
⊙		5PLPXCUIAPKX	2BR93390	PC-60LG(LTR) CASSETTE ASSY (Excl.KMTW)		1	
⊙		2BR93380	5PLPXDSAPKX	PC-60LG(A4) CASSETTE ASSY (KMTW only)	1		
	001	*5MMX883SD004	2BS06230	PLATE BOTTOM	1	1	1
	002	*5MVVL221GE1H	2BS06430	LABEL OPERATION (Excl.KMTW)		1	1
	002	*5MVVL221GE1J	2BR06510	LABEL OPERATION J (KMTW)	1		
⊙	003	*5MVS421RN006	2FP06040	SHEET FRICTION		1	1
⊙	003	*5MVS421RN004	2BS06390	SHEET FRICTION	1		
	004	*302BS06061	2BS06061	PLATE SIDE L	1	1	1
	005	*5MVX543DH002	2BS06470	HOLDER DIAL	1	1	1
	006	*5MVM586SH001	2B700210	DIAL CASSETTE	1	1	1
	007	*5MVVL171WN03	3DD06160	LABEL SIZE LGL	1	1	1
	008	*5MVX642DG001	2BS06490	LOCK LEVER SIDE	1	1	1
	009	*5MMW166LD010	2B700070	SPRING LOCK GUIDE	2	2	2
	010	*5MMX653LD004	2BS06220	EARTH PLATE	1	1	1
⊙	011	*5MVX432DN005	2BS06450	LOCK BOTTOM	1	1	1
	012	*5MMW251LD048	2BS06150	SP STOPPER BOTTOM	1	1	1
	013	*5MVG127DB046	2B700190	GEAR CASSETTE	1	1	1
	014	*5MMW161LD045	2BS06120	SPRING FEED L	1	1	1
⊙	015	*5MVM164DN007	2BS06320	BUSH4	2	2	2
⊙	016	*5MVT774DN001	2BS06410	ROLLER FEED	1	1	1
	017	*5MMW161LD044	2BM22440	SPRING FEED R	1	1	1
	018	*5MMW682LD005	2BS06210	SPRING BOTTOM EARTH		1	1
	018	*5MMW682LD007	2BR06390	SPRING BOTTOM EARTH	1		
	019	*5MMW151SD003	2BS06100	SPRING END	1	1	1
	020	*5MVX664DN001	2BS06520	END FENCE	1	1	1
	021	*5MVX642DG002	2BS06500	LOCK LEVER END	1	1	1
	022	*302BS06051	2BS06051	PLATE SIDE R	1	1	1
	023	*5MMW682LD004	2BS06200	SPRING BOTTOM		1	1
	023	*5MMW682LD006	2BR06380	SPRING BOTTOM	1		
⊙	024	*5MVX764DN001	2BS06530	LEVER INDICATOR	1	1	1
	025	*5MVX422SD002	2BS06440	INDICATOR PAPER	1	1	1
	026	*5MVB987SH018	3DD06010	BASE CASSETTE LGL	1	1	1
	027	*5MVX853SH003	2BS06540	COVER ROLLER	1	1	1
	028	*5MMW151LD004	2BS06090	SPRING RETARD	1	1	1
	029	*5MVX644DN001	2BS06510	HOLDER RETARD	1	1	1
	030	*5MVX632SH005	2BS06480	GUIDE RETARD	1	1	1
⊙	031	*5AAVR0LL+052	2BR06520	RETARD ROLL ASSY	1	1	1

- Parts with "*" are component parts or sub-assemblies of the assembly appearing immediately above them.
- Parts with "⊙" indicates the spare parts.

- Parts with "•" are component parts or sub-assembly with "•" appearing immediately above them.

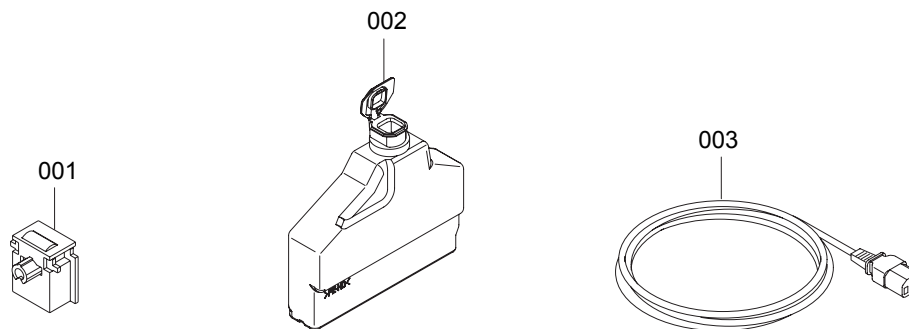

FIG. 13 Accessories

2F3/2F4-6.0

SP	Ref. No.	Part.No.	Alternative.	Description	Quantity		
					110	120	230
⊙	001	5AAYTK20++07	2B570060	GC-3 KIT	1	1	1
⊙	002	2D969140	5AAVB0TLE005	BOTTLE ASSY	2	2	2
	003	5AACAC485ASA++P	2B127020	AC CORD ASSY (KMAUS)			1
	003	5AACAC484BSA++P	2B127010	AC CORD ASSY (KMUK)			1
	003	5AACAC476EEA++P	2FP27140	AC CORD ASSY (Excl. KMUK/KMAUS)			1
	003	5GS2BR02130A	2BR69470	AC CORD ASSY (KMA)(KMTW)	1	1	

- Parts with "•" are component parts or sub-assemblies of the assembly appearing immediately above them.
- Parts with "⊙" indicates the spare parts.

- Parts with "••" are component parts or sub-assembly with "•" appearing immediately above them.

FIG. 14 Packing Assemblies

SP	Ref. No.	Part.No.	Alternative.	Description	Quantity		
					110	120	230
⊙	001	302F300690	2F300690	PACKING ASSY/B-26(KME) (16 PPM)			1
⊙	001	302F400360	2F400360	PACKING ASSY/B-27(KME) (24 PPM)			1
⊙	002	302F300770	2F300770	PACKING ASSY/B-26(KMA) (16 PPM)		1	
⊙	002	302F400370	2F400370	PACKING ASSY/B-27(KMA) (24 PPM)		1	
⊙	003	302F300A20	2F300A20	PACKING ASSY/B-26(KMTW) (16 PPM)	1		
⊙	003	302F400540	2F400540	PACKING ASSY/B-27(KMTW) (24 PPM)	1		
⊙	004	5KKF204500A4	2A883150	POLY BAG	1	1	1

• Parts with "*" are component parts or sub-assemblies of the assembly appearing immediately above them.

• Parts with "⊙" indicates the spare parts.

• Parts with "••" are component parts or sub-assembly with "•" appearing immediately above them.

INDEX

2F3/2F4-8

SP	Part.No.	Alternative.	Description	Fig.No.
⊙	2B720380	5MVG127DW004	GEAR IDLE Z16	2
⊙	2BR93380	5PLPXDSAPKX	PC-60LG(A4) CASSETTE ASSY	12
	2BS16431	2BS16431	LEVER LOCK	5
⊙	2D927090	5AAXTM016GEA++P	THERMISTOR ASSY	6
⊙	2D968390	5AAYA80E++03	FRAME MP ASSY	9
⊙	2D969140	5AAVB0TLE005	BOTTLE ASSY	13
	302BS06051	2BS06051	PLATE SIDE R	12
	302BS06061	2BS06061	PLATE SIDE L	12
	302D902311	2D902311	ROD INTERLOCK	2
	302D902372	2D902372	COVER HARNESS	2
⊙	302D902391	2D902391	BRACKET FD GEAR	2
	302D902542	2D902542	BRACKET FAN	2
	302D903011	2D903011	BOX CONTROLLER	4
	302D903071	2D903071	RAIL OPTION	4
⊙	302D904042	2D904042	COVER SIDE	1
⊙	302D904051	2D904051	COVER REAR	1
⊙	302D904301	2D904301	COVER PANEL TW	1
	302D906012	2D906012	TRAY M/P	10
⊙	302D915211	2D915211	GEAR DRIVE FUSER Z22	3
	302D916051	2D916051	BASE FEED	5
	302D916071	2D916071	GUIDE PAPER	5
⊙	302D916081	2D916081	PAPER CHUTE	5
⊙	302D916221	2D916221	GEAR IDLE Z23S	5
	302D920012	2D920012	ACTUATOR SOL	6
⊙	302D920041	2D920041	GEAR EXIT Z15S	6
⊙	302D922041	2D922041	GEAR Z35S	3
⊙	302D922051	2D922051	GEAR Z30S	3
⊙	302D922061	2D922061	GEAR Z38S-Z14S	3
⊙	302D922071	2D922071	GEAR Z38S	3
⊙	302D922081	2D922081	GEAR CL Z21S	3
⊙	302D922101	2D922101	GEAR Z93S-Z24S	3
⊙	302D922111	2D922111	GEAR Z48S	3
⊙	302D922141	2D922141	GEAR Z14-Z20	3
⊙	302D922161	2D922161	GEAR Z21H-Z22H	3
⊙	302D922181	2D922181	GEAR Z72H-Z22H	3
⊙	302D924061	2D924061	COVER PANEL E	1
	302D925010	2D925010	COVER FUSER L	6
	302D925020	2D925020	RING STOP	6
⊙	302D944010	2D944010	SOLENOID M/P ASSY	9
⊙	302F300000	2F300000	TRAY M/P ASSY	10
⊙	302F300290	2F300290	FEED TRANS UNIT	5
⊙	302F300330	2F300330	KEY BOARD ASSY	1
⊙	302F300340	2F300340	KEY BOARD ASSY	1
⊙	302F300350	2F300350	KEY BOARD ASSY	1
⊙	302F300370	2F300370	COVER LEFT ASSY	1
⊙	302F300390	2F300390	COVER RIGHT ASSY	1
⊙	302F300410	2F300410	SENSOR ID ASSY	2
⊙	302F300430	2F300430	WASTE TONER ASSY	2
⊙	302F300441	2F300441	TONER MOTOR ASSY	2
	302F300660	2F300660	BRACKET HV MAIN ASSY	3

SP	Part.No.	Alternative.	Description	Fig.No.
	302F300670	2F300670	DISCHARGER ASSY	5
⊙	302F300690	2F300690	PACKING ASSY/B-26(KME)	14
⊙	302F300770	2F300770	PACKING ASSY/B-26(KMA)	14
⊙	302F300830	2F300830	COVER TOP ASSY	1
⊙	302F300850	2F300850	ROLLER TRANSFER ASSY	5
⊙	302F300870	2F300870	BRACKET HV ASSY	2
⊙	302F300890	2F300890	BRACKET FD GEAR ASSY	2
⊙	302F300A20	2F300A20	PACKING ASSY/B-26(KMTW)	14
⊙	302F300A60	2F300A60	KEY BOARD ASSY	1
⊙	302F301241	2F301241	P.W.B.ASSY KP-1138 FLASH DIMM	4
⊙	302F301300	2F301300	P.W.B.ASSY KP1103 ENGRLY	3
⊙	302F301320	2F301320	P.W.BOARD ASSY SENSOR	2
⊙	302F301350	2F301350	P.W.B.ASSY ENGINE WITH SOFTWARE(SP)	4
⊙	302F302010	2F302010	ROLLER FD LOW	2
	302F302020	2F302020	SPRING EARTH FD	2
	302F302030	2F302030	PIN CONTACT BIAS	2
⊙	302F304020	2F304020	ROLLER FD	1
	302F304030	2F304030	DISCHARGER FD	1
⊙	302F311021	2F311021	COVER LED	7
⊙	302F324000	2F324000	ROLLER REGIST UP	5
⊙	302F324020	2F324020	ROLLER REGIST LOW	5
	302F324030	2F324030	SHAFT ROLL GUIDE	5
⊙	302F324040	2F324040	SENSOR DOC	5
⊙	302F325000	2F325000	ROLLER EXIT	6
	302F325010	2F325010	STUD SCREW M3	6
	302F325020	2F325020	SEAL HEATER R	6
	302F325030	2F325030	LABEL EXIT	6
⊙	302F325040	2F325040	GEAR JOINT Z36	6
⊙	302F325060	2F325060	GEAR IDLE Z18	6
⊙	302F325070	2F325070	PULLEY EXIT	6
⊙	302F331001	2F331001	STEPPING MOTOR PRO	3
⊙	302F331010	2F331010	PLATE DRIVE MAIN	3
⊙	302F331022	2F331022	GEAR Z40H	3
	302F331030	2F331030	BRACKET MOTOR	3
	302F331041	2F331041	PLATE IDLE ARM	3
	302F331050	2F331050	LEVER PLATE IDLE	3
⊙	302F331060	2F331060	CAM GEAR Z34H	3
⊙	302F331080	2F331080	LEVER CAM	3
	302F331090	2F331090	SPRING IDLE ARM	3
	302F331100	2F331100	SPRING LEVER	3
⊙	302F331120	2F331120	CLUTCH REGIST	3
⊙	302F331130	2F331130	CLUTCH FEED	3
	302F331140	2F331140	BRACKET DRIVE FEED	3
	302F331150	2F331150	BRACKET HV MAIN	3
⊙	302F331160	2F331160	HOOK CRANK	3
	302F331170	2F331170	SPRING HOOK CRANK	3
	302F331180	2F331180	PIN HV CONTACT	3
	302F331190	2F331190	CONTACT MAIN B	3
	302F331200	2F331200	SPRING HV MAIN	3
⊙	302F331210	2F331210	SHAFT CLUTCH B	3

• Parts with "⊙" indicates the spare parts.

SP	Part.No.	Alternative.	Description	Fig.No.
⊙	302F331220	2F331220	SHAFT CLUTCH	3
⊙	302F331250	2F331250	GEAR Z43S	3
⊙	302F331260	2F331260	GEAR Z56H-Z20S	3
⊙	302F344010	2F344010	FAN MOTOR	2
⊙	302F344020	2F344020	FAN MOTOR	3
⊙	302F344030	2F344030	FAN MOTOR	2
⊙	302F344040	2F344040	DC MOTOR	3
⊙	302F344050	2F344050	STEPPING MOTOR FEED	3
⊙	302F345011	2F345011	TRANS ASSY HI VOLTAGE DLP	2
⊙	302F345021	2F345021	TRANS ASSY HI VOLTAGE MAIN	2
⊙	302F345030	2F345030	SWITCHING REGULATOR 230V	4
⊙	302F346010	2F346010	CONN. CORD ASSY LEDRLY-BLH	7
⊙	302F346020	2F346020	CONN. CORD ASSY LEDRLY-BLH	7
	302F346060	2F346060	CONN. CORD ASSY S02880	4
	302F346080	2F346080	CONN. CORD ASSY	3
	302F346090	2F346090	CONN.CORD ASSY S03106	2
	302F346110	2F346110	CONN.CORD ASSY S03108	4
	302F346140	2F346140	CONN. CORD ASSY S03113	2
⊙	302F380271	2F380271	P.W.B.MAIN KIT	4
⊙	302F393010	2F393010	DK-510 DRUM UNIT	7
⊙	302F393021	2F393021	DV-510K DLP UNIT K	8
⊙	302F393031	2F393031	DV-510Y DLP UNIT Y	8
⊙	302F393041	2F393041	DV-510C DLP UNIT C	8
⊙	302F393051	2F393051	DV-510M DLP UNIT M	8
⊙	302F393070	2F393070	FK-510(E) FUSER UNIT	6
⊙	302F393080	2F393080	FK-510(U) FUSER UNIT	6
⊙	302F393090	2F393090	LK-510 LED HEAD UNIT	7
⊙	302F393100	2F393100	DR-510A DRIVE PRO UNIT	3
⊙	302F393110	2F393110	DR-510B DRIVE FEED UNIT	3
⊙	302F393120	2F393120	DR-510C DRIVE FUSER UNIT	3
⊙	302F393131	2F393131	DV-512Y DLP UNIT Y	8
⊙	302F393141	2F393141	DV-512M DLP UNIT M	8
⊙	302F393151	2F393151	DV-512C DLP UNIT C	8
⊙	302F393161	2F393161	DV-512K DLP UNIT K	8
⊙	302F393170	2F393170	TR-510 PRE TRANSFER UNIT	11
⊙	302F393190	2F393190	MC-510 MCH ASSY	7
⊙	302F393200	2F393200	CL-510 CLEANING UNIT	11
⊙	302F400170	2F400170	KEY BOARD ASSY	1
⊙	302F400180	2F400180	KEY BOARD ASSY	1
⊙	302F400190	2F400190	KEY BOARD ASSY	1
⊙	302F400360	2F400360	PACKING ASSY/B-27(KME)	14
⊙	302F400370	2F400370	PACKING ASSY/B-27(KMA)	14
⊙	302F400490	2F400490	BRACKET HV ASSY	2
⊙	302F400540	2F400540	PACKING ASSY/B-27(KMTW)	14
⊙	302F400570	2F400570	KEY BOARD ASSY	1
⊙	302F400600	2F400600	BRACKET HV ASSY	2
⊙	302F401280	2F401280	P.W.B. ASSY FUSER	6
⊙	302F401300	2F401300	P.W.B.ASSY PA0008 LEDRLY	2
⊙	302F401330	2F401330	P.W.B.ASSY ENGINE WITH SOFTWARE(SP)	4
	302F403000	2F403000	BOX CONTROLLER	4

SP	Part.No.	Alternative.	Description	Fig.No.
	302F425012	2F425012	PLATE FUSER L	6
	302F425021	2F425021	PLATE FUSER R	6
	302F425030	2F425030	STAY FUSER A	6
	302F425040	2F425040	STAY FUSER B	6
	302F425050	2F425050	STAY FUSER C	6
	302F425060	2F425060	PLATE PRESS L	6
	302F425070	2F425070	PLATE PRESS R	6
	302F425080	2F425080	PLATE RELEASE L	6
	302F425090	2F425090	PLATE RELEASE R	6
	302F425100	2F425100	PLATE PITCH	6
	302F425110	2F425110	PLATE SEPARATOR	6
	302F425120	2F425120	COVER FUSER UP	6
	302F425130	2F425130	PULLEY PRESS	6
	302F425141	2F425141	COVER FUSER L	6
	302F425151	2F425151	COVER FUSER R	6
	302F425161	2F425161	GUIDE EXIT	6
	302F425171	2F425171	GUIDE EXIT UP	6
	302F425180	2F425180	GUIDE ENTRANCE	6
	302F425193	2F425193	HOLDER BELT L	6
	302F425203	2F425203	HOLDER BELT R	6
⊙	302F425212	2F425212	ACTUATOR FUSER	6
⊙	302F425220	2F425220	SPRING PRESS	6
	302F425230	2F425230	SPRING EXIT L	6
	302F425240	2F425240	SPRING EXIT R	6
	302F425250	2F425250	SPRING PULLEY EXIT	6
	302F425260	2F425260	SPRING ACTUATOR	6
⊙	302F425270	2F425270	BELT FUSER	6
⊙	302F425281	2F425281	ROLLER HEAT	6
⊙	302F425290	2F425290	ROLLER BELT	6
⊙	302F425301	2F425301	LAMP HEATER 240V	6
⊙	302F425311	2F425311	LAMP HEATER 120V	6
⊙	302F425330	2F425330	ROLLER EXIT	6
	302F425341	2F425341	GUIDE CHANGE	6
⊙	302F425350	2F425350	GEAR IDLE Z15S-Z18S	6
⊙	302F425361	2F425361	GEAR EXIT Z18S	6
	302F425370	2F425370	SHAFT EXIT	6
	302F425390	2F425390	SLEEVE FUSER GEAR	6
	302F425400	2F425400	SEAL LUMP HOLD R	6
	302F425410	2F425410	SEAL LUMP HOLD L	6
	302F425420	2F425420	SEAL COVER FUSER	6
⊙	302F425430	2F425430	ROLLER BELT A	6
⊙	302F425440	2F425440	GEAR HEAT Z43S	6
⊙	302F425450	2F425450	BUSH FUSER	6
	302F425460	2F425460	SPRING SLEEVE	6
	302F425470	2F425470	SPRING CHANGE	6
⊙	302F425480	2F425480	RING STOP	6
⊙	302F431000	2F431000	STEPPING MOTOR PRO	3
⊙	302F431010	2F431010	STEPPING MOTOR FUSER	3
⊙	302F431020	2F431020	STEPPING MOTOR FEED	3
	302F444010	2F444010	FAN MOTOR	4

• Parts with "⊙" indicates the spare parts.

SP	Part.No.	Alternative.	Description	Fig.No.
⊙	302F445010	2F445010	SWITCHING REGULATOR 230V	4
⊙	302F445020	2F445020	SWITCHING REGULATOR	4
	302F446010	2F446010	CONN.CORD ASSY HEATER-DRAWER	6
	302F446020	2F446020	CONN.CORD ASSY S03109	2
⊙	302F446051	2F446051	SHIELD FFC ASSY	7
	302F446100	2F446100	CONN.CORD ASSY S03142	2
⊙	302F446120	2F446120	CONN.CORD ASSY S03144	7
⊙	302F480040	2F480040	P.W.B.MAIN KIT	4
⊙	302F493010	2F493010	FK-520(E) FUSER UNIT	6
⊙	302F493020	2F493020	FK-520(U) FUSER UNIT	6
⊙	302F493030	2F493030	DR-520A DRIVE PRO UNIT	3
⊙	302F493040	2F493040	DR-520B DRIVE FEED UNIT	3
⊙	302F493050	2F493050	DR-520C DRIVE FUSER UNIT	3
⊙	302F493061	2F493061	DK-520 DRUM UNIT	7
⊙	302F493081	2F493081	LK-520 LED HEAD UNIT	7
⊙	302F493090	2F493090	TR-520 PRE TRANSFER UNIT	11
⊙	302FP06100	2FP06100	ROLLER GUIDE ASSY	5
⊙	302GV45010	2GV45010	SWITCHING REGULATOR /J	4
⊙	302GV46010	2GV46010	CONN.CORD ASSY S03145	7
⊙	302GV93090	2GV93090	LK-520	7
	303BH26021	3BH26021	PLATE OPTION	4
	5AACAC476EEA++P	2FP27140	AC CORD ASSY	13
	5AACAC484BSA++P	2B127010	AC CORD ASSY	13
	5AACAC485ASA++P	2B127020	AC CORD ASSY	13
	5AACCN5M5GEA++P	2D926060	CONN. CORD ASSY S02849	2
	5AACCN5M6GEA++P	2D926070	CONN. CORD ASSY S02850	4
	5AACCN5M7GEA++P	2D926080	CONN. CORD ASSY S02851	2
⊙	5AACCN5M8GEA++P	2D926090	CONN. CORD ASSY S02852	4
	5AACCN5N2GEA++P	2D926120	CONN. CORD ASSY S02856	2
	5AACCN5N3GEA++P	2D926130	CONN. CORD ASSY S02857	6
	5AACCN5N4GEA++P	2D926140	CONN. CORD ASSY S02858	6
	5AACCN5N7GEA++P	2D926160	CONN. CORD ASSY S02861	2
	5AACCN5P6GEA++P	2D926240	CONN. CORD ASSY S02870	2
	5AACCN5R4GEA++P	2D926260	CONN. CORD ASSY S02877	2
	5AACCN5S8GEA++P	2D926280	CONN. CORD ASSY S02975	2
	5AACCN5T1GEA++P	2D926310	CONN. CORD ASSY S02978	2
	5AACCN5T2GEA++P	2D926320	CONN. CORD ASSY S02979	2
	5AACCN5T4GEA++P	2D926340	CONN. CORD ASSY S02981	3
	5AACCN5U6GEA++P	2D926390	CONN. CORD ASSY S02988	5
⊙	5AAEZA80U++2++P	2D928740	SWITCHING REGULATOR	4
⊙	5AAPRIFC1030AHP	2D901460	P.W.B.ASSY KP-970 FUSER	6
⊙	5AAPRIFR2018AHR	2F301120	P.W.B.ASSY KP-1091 LEDRLY B26	2
⊙	5AAVCASET248	2BR00140	SEPARATOR M/P ASSY	10
⊙	5AAVCASET249	2BR00150	BOTTOM MULTI ASSY	10
⊙	5AAVGEAR+037	2BR70440	GEAR PICKUP	5
⊙	5AAVGEAR+044	2D969180	GEAR Z29S ASSY	3
⊙	5AAVGEAR+045	2D969870	GEAR Z22S ASSY	3
⊙	5AAVR0LL+047	2CL16090	ROLLER FEED ASSY	5
⊙	5AAVR0LL+048	2CL16100	ROLLER PICKUP ASSY	5
⊙	5AAVR0LL+050	2CL16120	ROLL MID M/P ASSY	9

SP	Part.No.	Alternative.	Description	Fig.No.
⊙	5AAVR0LL+051	2CL16130	ROLLER M/P ASSY	9
⊙	5AAVR0LL+052	2BR06520	RETARD ROLL ASSY	12
⊙	5AAYA37E++35	2BR68470	HOLDER FEED ASSY	5
⊙	5AAYA80E++71	2D969810	BRACKET HV DLP K ASSY	2
⊙	5AAYA80E++72	2D969820	BRACKET HV DLP C ASSY	2
⊙	5AAYA80E++73	2D969830	BRACKET HV DLP Y ASSY	2
⊙	5AAYA80E++75	2D969860	CLEANER ID ASSY	2
⊙	5AAYTK20++07	2B570060	GC-3 KIT	13
⊙	5ESP01000101+01	SP000310	PUSH SWITCH 01 SN	2
	5EYBE1392700101	YB001900	FERRITE CORE	2
	5FRHA3A10702+01	RHOA0040	M.GLAZE R. 100M 1W	5
⊙	5FSF03090001+01	SPOA0360	PUSH SWITCH 03 SN	2
⊙	5FZNT2400902+01	WNAA1170	STEPPING MOTOR FUSER	3
⊙	5FZPB1212920101	WPOA0540	LAMP HEATER LOW 120V	6
⊙	5FZSA2401020309	WSAA0170	SOLENOID	6
	5GS2BR02130A	2BR69470	AC CORD ASSY	13
⊙	5HNXEESX1235+01	2D902860	PT.SENSOR EE-SX1235A	2
⊙	5HZPB1214220901	2D920440	LAMP HEATER UP 120V	6
⊙	5HZPB2411520201	2D920450	LAMP HEATER LOW 240V	6
⊙	5HZPB2412120801	2D920400	LAMP HEATER UP 240V	6
⊙	5KKF204500A4	2A883150	POLY BAG	14
⊙	5MBE6804ZZNR	2D920350	FUSER BEARING	6
	5MBP2518WXSP	E0025180	SPRING PIN /M2.5 X 18 S-BLK	6
	5MBWN92F02NN	C2890150	POLY WASHER / M9.2X 15X0.2T	3
	5MMB861SD003	2D903030	PANEL REAR	2
	5MMB861SD004	2D902200	PLATE SHIELD PWB	4
	5MMS111SL002	2BY20050	NUT FUSER A	6
⊙	5MMS632LD001	2D902320	PLATE EARTH HV A	2
	5MMS656AX001	2D922260	SHEET MOTOR FEED	3
	5MMS866SD001	2D908510	PLATE FRAME DRUM	2
	5MMS884SD001	2D903020	LID CONTROLLER	4
⊙	5MMT263SN012++R	2D903100	SCREW OP	4
	5MMT664SN002	2BR16370	SHAFT PICKUP	5
	5MMT722SZ001	2BR20370	SHAFT EXIT	6
⊙	5MMT888AX024	2D920060	ROLLER FIX UP	6
⊙	5MMT888AX025	2D920070	ROLLER FIX LOW	6
	5MMW151LD004	2BS06090	SPRING RETARD	12
	5MMW151LD007	2D920280	SPRING ACTUATOR	6
	5MMW151SD003	2BS06100	SPRING END	12
	5MMW161LD043	2BR02450	SPRING CAM M/P	9
	5MMW161LD044	2BM22440	SPRING FEED R	12
	5MMW161LD045	2BS06120	SPRING FEED L	12
	5MMW161LD056	2D908360	SPRING LOCK L	7
	5MMW161LD057	2D908370	SPRING LOCK R	7
	5MMW161SD009	2BR02530	SP ACTUATOR M/P C	9
	5MMW161SD010	2BR02520	SP ACTUATOR M/P B	9
	5MMW161SD012	2D920260	SPRING EXIT L	6
	5MMW161SD013	2D920270	SPRING EXIT R	6
	5MMW161SD014	2D916260	SPRING ACTUATOR REG	5
	5MMW166LD010	2B700070	SPRING LOCK GUIDE	12

• Parts with "⊙" indicates the spare parts.

SP	Part.No.	Alternative.	Description	Fig.No.
⊙	5MMW171LD007	2D920310	RING STOP	6
	5MMW222LD002	2BR02280	SPRING LEVER EF	2
	5MMW222LD003	2D902580	SPRING CONTACT CLN	2
	5MMW241LD024	2D908000	SPRING EARTH	7
⊙	5MMW241SX005	2B716150	SPRING TRANS R	5
	5MMW251LD046	2BS04050	SPRING PULLEY	1
	5MMW251LD048	2BS06150	SP STOPPER BOTTOM	12
	5MMW251SD002	2BR16250	SPRING LOCK R	5
	5MMW251SX004	2D916060	SPRING TRANS	5
	5MMW261LD039	2BS06160	SPRING SEPARATOR	10
	5MMW261LD051	2BR02340	SP LOCK COVER M/P	2
	5MMW261LJ032	2BM21060	SPRING SOL	6
	5MMW261SM001	2BS06170	SPRING LOCK M/P	10
	5MMW311LD003	2B702130	SPRING HV CONTACT	3
	5MMW341LD008	2BR16240	SPRING REGIST R	5
	5MMW341LD011	2D916250	SPRING REGIST L	5
	5MMW361SD005	2D920250	SPRING PRESS	6
	5MMW451LD001	2B700570	SPRING INTER LOCK	2
	5MMW461SD004	2BS06190	SP BOTTOM M/P R	10
	5MMW461SD006	2D916020	SP BOTTOM M/P L	10
	5MMW463LD001	2D902570	SPRING FD LOW	1
	5MMW501LD003	2D920300	SPRING PULLEY EXIT	6
	5MMW601SD001	2BR02440	SPRING MID M/P	9
	5MMW641SD001	2D916130	SPRING EARTH B	5
	5MMW641SD002	2D916270	SPRING EARTH C	5
	5MMW641SD003	2D916280	WIRE EARTH M/P	5
	5MMW682LD004	2BS06200	SPRING BOTTOM	12
	5MMW682LD005	2BS06210	SPRING BOTTOM EARTH	12
	5MMW682LD006	2BR06380	SPRING BOTTOM	12
	5MMW682LD007	2BR06390	SPRING BOTTOM EARTH	12
	5MMW803SD001	2D903060	ROD SW POWER	4
	5MMX221SW002	3FW02530	CORD KEEP	2
	5MMX332SD003	2D902550	PLATE EARTH FD	2
	5MMX422LD012	2D916140	PLATE EARTH MP	5
	5MMX431LD017	2D902410	BRACKET ROLLER PINCH	2
	5MMX543LD006	2D916110	PLATE EARTH TC	5
	5MMX543LD007	2D916210	PLATE EARTH FEED	5
	5MMX632SD006	2D902380	PLATE EARTH FUSER	2
	5MMX641RD001	2D920220	PLATE HEATER L	6
	5MMX641SD003	2D920170	PLATE PRESS L	6
	5MMX641SD004	2D920180	PLATE PRESS R	6
	5MMX641SD005	2D920190	PLATE RELEASE L	6
	5MMX641SD006	2D920200	PLATE RELEASE R	6
	5MMX653LD004	2BS06220	EARTH PLATE	12
	5MMX733SD001	2D903040	BRACKET BOX	4
	5MMX763SD003	2D922090	PLATE DRIVE FUSER	3
	5MMX876SD003	2D920050	FRAME FUSER	6
	5MMX883SD004	2BS06230	PLATE BOTTOM	12
	5MMZ242LD002	2D902330	PLATE EARTH HV B	2
⊙	5MVB661XF001	2D902530	OZONE FILTER	2

SP	Part.No.	Alternative.	Description	Fig.No.
	5MVB663KB003	2D920120	COVER FUSER R	6
	5MVB732XB002	2D922020	COVER DRIVE FEED	3
⊙	5MVB761SH013	2D904100	COVER PANEL FRENCH	1
⊙	5MVB761SH014	2D904110	COVER OABEL ITALIAN	1
	5MVB833KB004	2D920330	GUIDE ENTRANCE LOW	6
	5MVB864SH009	2BS06250	BASE M/P	10
⊙	5MVB866CH022	2BS04110	COVER FRONT	1
	5MVB866KB002	2D920320	FRAME FUSER UP	6
⊙	5MVB878SH001	2D906020	COVER M/P	10
⊙	5MVB986SH026	2D904010	COVER TOP	1
⊙	5MVB987SH018	3DD06010	BASE CASSETTE LGL	12
⊙	5MVG038DN002	2D916230	GEAR JOINT Z26S	5
⊙	5MVG115DB002	2BM14540	GEAR WORM	3
⊙	5MVG126DN015	2BS16240	GEAR REGIST Z19S	5
⊙	5MVG127DB046	2B700190	GEAR CASSETTE	12
⊙	5MVG127DH001	2B700380	GEAR MANUAL	10
⊙	5MVG127DN076	2BS02220	GEAR ROLL FD Z18	1,2
⊙	5MVG127DN122	2D902400	GEAR FD Z15-Z18	2
⊙	5MVG133DN008	2BS02230	GEAR M/P Z27	9
⊙	5MVG137DN014	2BS02240	GEAR IDLE Z25	2
⊙	5MVG137DN036	2BS16250	GEAR FEED IDLE Z29S	5
⊙	5MVG138DN047	2BS02260	GEAR FD Z28	2
⊙	5MVG138DN048	2BD02270	GEAR FD Z29	2
⊙	5MVG148DN060	2BS16270	GEAR REG Z22S-Z32S	5
⊙	5MVG148DN063	2BS02280	GEAR M/P Z40	9
⊙	5MVG154BN001	2D922130	GEAR Z43S	3
⊙	5MVG154XN001	2D920020	GEAR HEAT Z43S	6
⊙	5MVG158XN005	2D916010	GEAR MID Z42S	9
	5MVL673DH003	2D906030	GUIDE M/P L	10
	5MVL673DH004	2D906040	GUIDE M/P R	10
	5MVM111RB002	2BR20450	RUBBER PIN	6
⊙	5MVM164DN007	2BS06320	BUSH4	12
⊙	5MVM176DN019	2B716270	BUSH POM A	5
⊙	5MVM176DN034	2D922240	BUSH SHAFT CLUTCH	3
⊙	5MVM176DN035	2D922250	BUSH FRAME	2
⊙	5MVM180XN002	2D920030	BUSH FUSER	6
⊙	5MVM221DB002	2BS16290	BUSH REGIST	5
⊙	5MVM222XN001	2BS16300	BUSH FEED	5
⊙	5MVM266DN006	2BS02290	BUSH FD	1,2,6
⊙	5MVM273DB006	2BS04170	ROLLER PINCH	1,2
⊙	5MVM331DN002	2D915200	BUSH DRIVE FUSER	3
	5MVM586SH001	2B700210	DIAL CASSETTE	12
⊙	5MVQ411RX001++R	2D903140	EMI GASKET	4
⊙	5MVS421RN004	2BS06390	SHEET FRICTION	12
⊙	5MVS421RN006	2FP06040	SHEET FRICTION	12
⊙	5MVS721KF005	2D916150	SHEET REGIST	5
⊙	5MVT676CB003	2BS02320	SHAFT MID B	9
⊙	5MVT754SB001	2BS02330	ACTUATOR M/P A	9
⊙	5MVT774DN001	2BS06410	ROLLER FEED	12
	5MVVL171WN03	3DD06160	LABEL SIZE LGL	12

• Parts with "⊙" indicates the spare parts.

SP	Part.No.	Alternative.	Description	Fig.No.
	5MVVL221GE1H	2BS06430	LABEL OPERATION	12
	5MVVL221GE1J	2BR06510	LABEL OPERATION J	12
⊙	5MVX221RB014	2BS03110	FOOT	4
⊙	5MVX321DN014	2BS02340	BUSH MID M/P	9
	5MVX321NP001++R	2D902760	SHIELD CLAMP	4
⊙	5MVX322DB019	2BS16380	BUSH TRANSFER	5
	5MVX322DB023	2BS02350	LEVER EF	2
⊙	5MVX332DB015	2D904170	GUIDE STOCK	1
⊙	5MVX376DN001	2BS16390	HOLDER RELEASE	5
⊙	5MVX421SB021	2BS02360	ACTUATOR M/P C	9
	5MVX421SL001	2D908340	LEVER DRUM L	7
⊙	5MVX422DN007	2BS02370	HOLDER FEED M/P	9
	5MVX422SD002	2BS06440	INDICATER PAPER	12
	5MVX422SL003	2D908350	LEVER DRUM R	7
⊙	5MVX432DN005	2BS06450	LOCK BOTTOM	12
⊙	5MVX433DN002	2BS02380	CAM M/P	9
	5MVX433SH002	2BS03120	LEVER SW	4
	5MVX522DB006	2BS02390	LOCK COVER M/P	2
	5MVX522DN004	2BS02400	LEVER CAM	9
	5MVX533DN002	2BS06460	BRACKET BOTTOM	10
	5MVX543DH002	2BS06470	HOLDER DIAL	12
⊙	5MVX621SB010	2BS02410	ACTUATOR M/P B	9
	5MVX632SH005	2BS06480	GUIDE RETARD	12
	5MVX642DG001	2BS06490	LOCK LEVER SIDE	12
	5MVX642DG002	2BS06500	LOCK LEVER END	12
	5MVX642DH001	2BS16400	COVER BKT FEED	5
	5MVX644DN001	2BS06510	HOLDER RETARD	12
	5MVX662DN003	2BS02440	HOLDER CLUTCH M/P	9
⊙	5MVX663SB013	2BS16410	ACTUATOR PAPER	5
	5MVX664DN001	2BS06520	END FENCE	12
	5MVX664SH004	2BS16420	BRACKET FEED	5
⊙	5MVX731CB004	2D920150	ACTUATOR FUSER	6
⊙	5MVX732CB003	2BS04310	ACTUATOR FD	1
	5MVX733DN002	2D916090	HOOK RELEASE	5
⊙	5MVX764DN001	2BS06530	LEVER INDICATOR	12
	5MVX833CB006	2D920140	GUIDE CHANGE	6
	5MVX843CB004	2BS16470	SHAFT RELEASE	5
	5MVX852CH002	2BS04340	FRAME FD	1
	5MVX853SH003	2BS06540	COVER ROLLER	12
	5MVX865KB003	2D920080	GUIDE EXIT	6
	5MVX866CH011	2FP02130	FRAME M/P	9
	5MVX866XB003	2D904060	FRAME FD LOW	1
	5MVX872KB001	2D920130	COVER FUSER LOW	6
	5MVX876SB009	2D903050	CASE PWB POWER	4
⊙	5PLPXCUAPKX	2BR93390	PC-60LG(LTR) CASSETTE ASSY	12
⊙	5PLPXZ7APKX	2BR93360	PC-60LG(A4) CASSETTE ASSY	12
⊙	7BE686ZZ++++H01	BE010080	FUSER BELT BEARING	6
⊙	WNAA1060	5FZNF0506001+03	FAN MOTOR	4
⊙	YF0A1530	5FYFFQ15001++03	THERMOSTAT 250V150C	6

• Parts with "⊙" indicates the spare parts.

KYOCERA MITA EUROPE B.V.

Hoeksteen 40, 2132 MS Hoofddorp,
The Netherlands
Phone: +31.20.654.0000
Home page: <http://www.kyoceramita-europe.com>
Email: info@kyoceramita-europe.com

KYOCERA MITA NEDERLAND B.V.
Beechavenue 25, 1119RA Schiphol-Rijk
The Netherlands
Phone: +31.20.58.77.200

KYOCERA MITA (UK) LTD
8 Beacontree Plaza
Gillette Way Reading Berks RG2 0BS,
U.K.
Phone: +44.1189.311.500

KYOCERA MITA ITALIA S.p.A.
Via G. Verdi, 89 / 91, 20063 Cernusco s/N
Milano, Italy
Phone: +39.02.92179.1

S.A. KYOCERA MITA BELGIUM N.V.
Hermestraat 8A, 1930 Zaventem,
Belgium
Phone: +32.2.720.9270

KYOCERA MITA FRANCE S.A.
Parc Les Algorithmes Saint Aubin
91194 GIF-SUR-YVETTE,
France
Phone: +33.1.6985.2600

KYOCERA MITA ESPAÑA S.A.
Edificio Kyocera, Avda de Manacor No. 2,
28290 Las Matas (Madrid),
Spain
Phone: +34.91.631.8392

KYOCERA MITA FINLAND OY
Kirvesmiehenkatu 4, 00880 Helsinki,
Finland
Phone: +358.9.4780.5200

KYOCERA MITA (SCHWEIZ)
Hohlstrasse 614, 8048 Zürich
Switzerland
Phone: +41.1.908.4949

KYOCERA MITA DEUTSCHLAND GMBH
Otto-Hahn-Str. 12 D-40670 Meerbusch,
Germany
Phone: +49.2159.918.0

KYOCERA MITA GMBH AUSTRIA
Eduard-Kittenberger-Gasse 95,
1230 Wien,
Austria
Phone: +43.1.86338.210

KYOCERA MITA SVENSKA AB
Esbogatan 16B 164 75 Kista,
Sweden
Phone: +46.8.546.55000

KYOCERA MITA NORGE
Postboks 150 Oppsal, NO 0619 Oslo
Olaf Helsetsvei 6, NO 0694 Oslo,
Norway
Phone: +47.22.62.73.00

KYOCERA MITA DANMARK A/S
Ejby Industrivej 1, DK-2600 Glostrup,
Denmark
Phone: +45.5687.1100

KYOCERA MITA PORTUGAL LDA.
Rua do Centro Cultural, 41 (Alvalade) 1700-106 Lisbon,
Portugal
Phone: +351.21.842.9100

KYOCERA MITA SOUTH AFRICA (PTY) LTD.
527 Kyalami Boulevard,
Kyalami Business Park Midrand,
South Africa
Phone: +27.(0)11.540.2600

KYOCERA MITA AMERICA, INC.

Headquarters:
225 Sand Road,
Fairfield, New Jersey 07004-0008,
U.S.A.
Phone: (973) 808-8444

KYOCERA MITA AUSTRALIA PTY. LTD.
Level 3, 6-10 Talavera Road, North Ryde,
N.S.W. 2113 Australia
Phone: (02) 9888-9999

KYOCERA MITA NEW ZEALAND LTD.
1-3 Parkhead Place, Albany
P.O. Box 302 125 NHPC, Auckland,
New Zealand
Phone: (09) 415-4517

KYOCERA MITA (THAILAND) CORP., LTD.
9/209 Ratchada-Prachachem Road,
Bang Sue, Bangkok 10800, Thailand
Phone: (02) 586-0320

KYOCERA MITA SINGAPORE PTE LTD.
121 Genting Lane, 3rd Level,
Singapore 349572
Phone: 67418733

KYOCERA MITA HONG KONG LIMITED
11/F., Mita Centre,
552-566, Castle Peak Road,
Tsuen Wan, New Territories,
Hong Kong
Phone: 24297422

KYOCERA MITA TAIWAN Corporation.
7F-1~2, No.41, Lane 221, Gangchi Rd.
Neihu District, Taipei, Taiwan, 114. R.O.C.
Phone: (02) 87511560

KYOCERA MITA Corporation

2-28, 1-chome, Tamatsukuri, Chuo-ku
Osaka 540-8585, Japan
Phone: (06) 6764-3555
<http://www.kyoceramita.com>

KYOCERA MITA AMERICA, INC.

Headquarters:

225 Sand Road,
Fairfield, New Jersey 07004-0008
TEL : (973) 808-8444
FAX : (973) 882-6000

New York Branch:

1410 Broadway 23rd floor
New York, NY 10018
TEL : (917) 286-5400
FAX : (917) 286-5402

Northeastern Region:

225 Sand Road,
Fairfield, New Jersey 07004-0008
TEL : (973) 808-8444
FAX : (973) 882-4401

Midwestern Region:

201 Hansen Court Suite 119
Wood Dale, Illinois 60191
TEL : (630) 238-9982
FAX : (630) 238-9487

Western Region:

14101 Alton Parkway,
Irvine, California 92618-7006
TEL : (949) 457-9000
FAX : (949) 457-9119

Southeastern Region:

1500 Oakbrook Drive,
Norcross, Georgia 30093
TEL : (770) 729-9786
FAX : (770) 729-9873

Southwestern Region:

2825 West Story Road,
Irving, Texas 75038-5299
TEL : (972) 550-8987
FAX : (972) 252-9786

National Operation Center & National Training Center:

2825 West Story Road,
Irving, Texas 75038-5299
TEL : (972) 659-0055
FAX : (972) 570-5816

Latin America Division:

8240 N.W. 52nd. Terrace Dawson Building,
Suite 108 Miami, Florida 33166
TEL : (305) 421-6640
FAX : (305) 421-6666

KYOCERA MITA CANADA, LTD.

6120 Kestrel Road, Mississauga,
Ontario L5T 1S8, Canada
TEL : (905) 670-4425
FAX : (905) 670-8116

KYOCERA MITA MEXICO, S.A. DE C.V.

Av. 16 de Septiembre #407
Col. Santa Inés,
Azcapotzalco México,
D.F. 02130, México
TEL : (55) 5383-2741
FAX : (55) 5383-7804

©2008 KYOCERA MITA Corporation

<http://www.kyoceramita.com>

 **KYOCERA** is a trademark of Kyocera Corporation

Printed in U.S.A.